

ZRH-197P Air Riveting Hammer

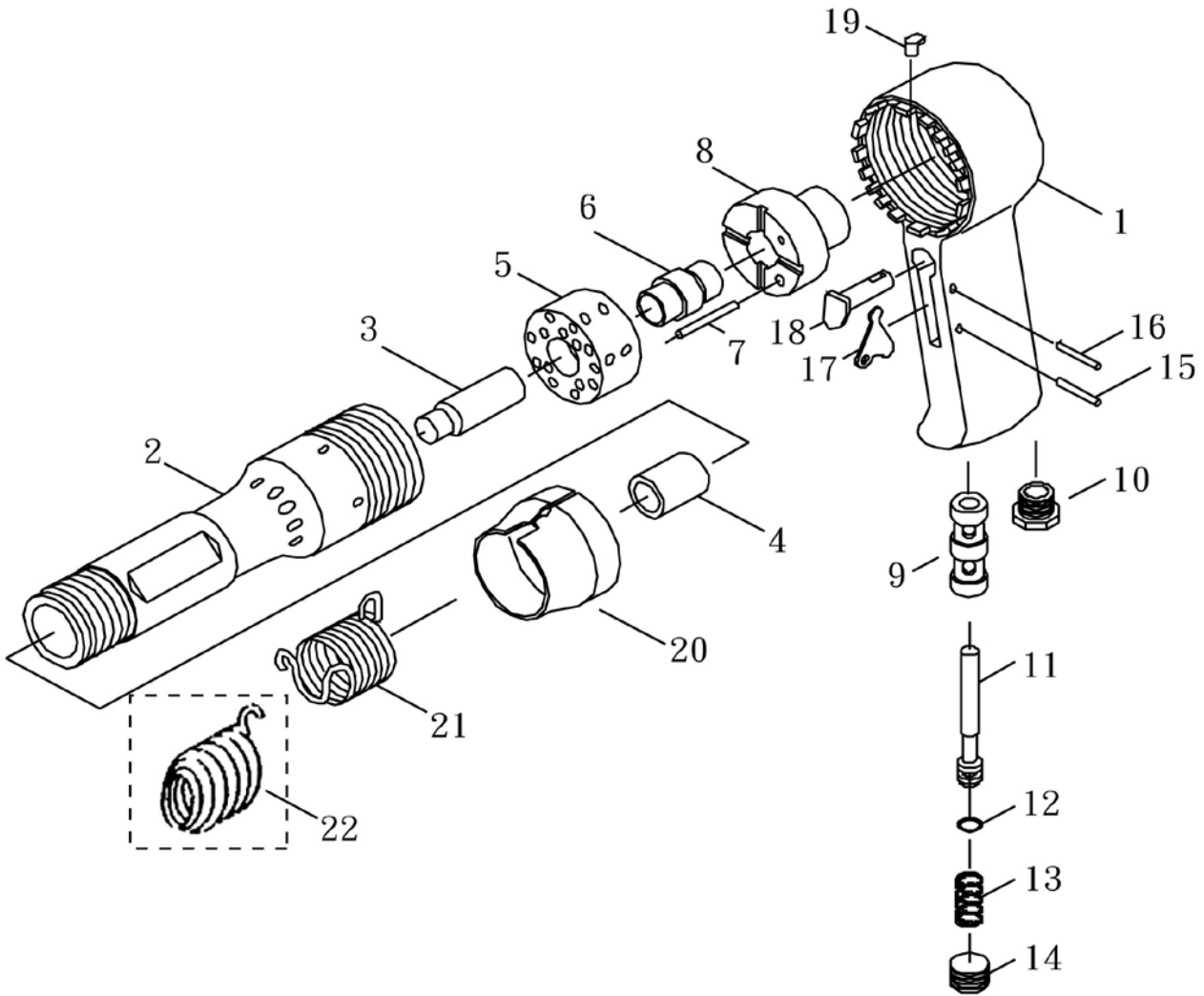

ZRH-197P Air Riveting Hammer

TECHNICAL DATA	Specification	Unit	Value
Chisel Shank Opening	inch(mm)		0.498(12.6)
Bore Diameter	inch(mm)		3/4(19.1)
Stroke Length	inch(mm)		5-13/16(132)
Blow Per Min.	B.P.M		900
Avg. Air Cons	cfm (l/min)		9.19(260)
Net Weight	lbs(kgs)		5.5(2.5)
Min. Hose Size	inch(mm)		3/8(10)

PARTS LIST

Index #	Part #	Description	Index #	Part #	Description
1.	ZRH197P-01	Handle	12.	ZRH197P-12	O-Ring
2.	ZRH197P-02	Cylinder(7X)	13.	ZRH197P-13	Spring
3.	ZRH197P-03	Piston(7X)	14.	ZRH197P-14	Plug
4.	ZRH197P-04	Bush	15.	ZRH197P-15	Pin
5.	ZRH197P-05	Valve Box	16.	ZRH197P-16	Roll Pin
6.	ZRH197P-06	Valve	17.	ZRH197P-17	Assistant Lever
7.	ZRH197P-07	Pin	18.	ZRH197P-18	Lever
8.	ZRH197P-08	Valve Seat	19.	ZRH197P-19	Stopper Pin
9.	ZRH197P-09	Throttle Bush	20.	ZRH197P-20	Exhaust Cover
10.	ZRH197P-10	Inlet Bushing	21.	ZRH197P-21	Retainer Spring(21.22Optional)
11.	ZRH197P-11	Valve Stem	22.	ZRH197P-22	Bee Hive Spring(21.22Optional)