

ZIW4207J 1/2" Micro Mini Air Impact Wrench

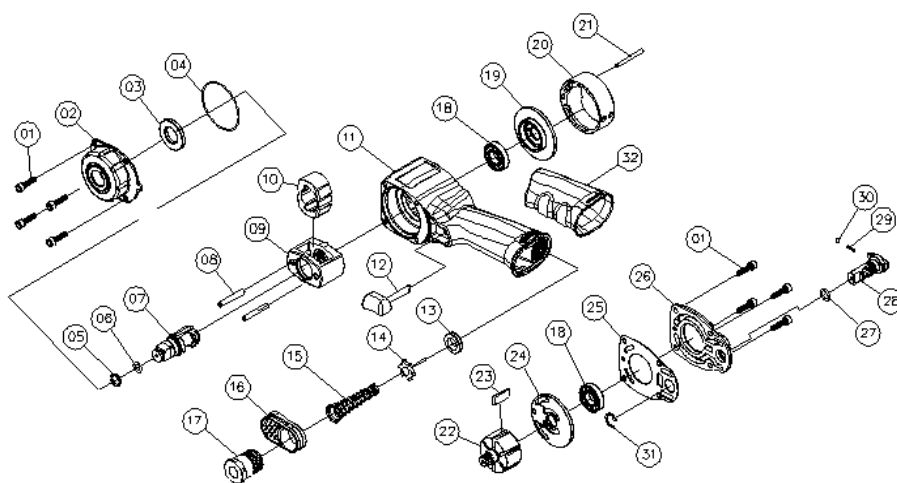

TECHNICAL DATA

Square Drive	inch	1/2"
Std. Bolt Size	mm	16
Free Speed	R.P.M	10,000
Max. Torque(10sec.)	ft-lb(N.M)	500(678)
Air Inlet Size	inch-NPT/PT	1/4
Hose Size	inch	3/8(10)
Avg. Air Consumption	cfm(l/min)	0.2
Net Weight	lbs (kgs)	3(1.37)

PARTS LIST

Index #	Part #	Description	Q'ty	Index #	Part #	Description	Q'ty
*1	ZIW4207J-01	Screw	8	17	ZIW4207J-17	Inlet Bushing	1
2	ZIW4207J-02	Hammer Housing	1	18	ZIW4207J-18	Ball Bearing	2
3	ZIW4207J-03	Anvil Bushing	1	19	ZIW4207J-19	Front Plate	1
*4	ZIW4207J-04	O-Ring	1	20	ZIW4207J-20	Cylinder	1
*5	ZIW4207J-05	Socket Retainer	1	21	ZIW4207J-21	Cylinder Pin	1
*6	ZIW4207J-06	Retainer O-Ring	1	22	ZIW4207J-22	Rotor	1
7	ZIW4207J-07	Anvil 1/2"	1	*23	ZIW4207J-23	Rotor Blade	6
8	ZIW4207J-08	Hammer Pin	2	24	ZIW4207J-24	Rear Plate	1
9	ZIW4207J-09	Hammer Cage	1	*25	ZIW4207J-25	Gasket	1
10	ZIW4207J-10	Hammer Dog	1	26	ZIW4207J-26	Housing cap	1
11	ZIW4207J-11	Motor Housing	1	*27	ZIW4207J-27	O-ring	1
12	ZIW4207J-12	Trigger	1	28	ZIW4207J-28	Reverse valve	1
*13	ZIW4207J-13	Throttle Bushing	1	*29	ZIW4207J-29	Spring	1
*14	ZIW4207J-14	Valve Stem	1	*30	ZIW4207J-30	Steel Ball	1
15	ZIW4207J-15	Spring	1	*31	ZIW4207J-31	Retainer	1
16	ZIW4207J-16	Exhaust Deflector	1	32	ZIW4207J-32	Grip	1

date : 2015.03.04