

# ZIR316 3/16" AIR HYDRAULIC STRAIGHT RIVETER

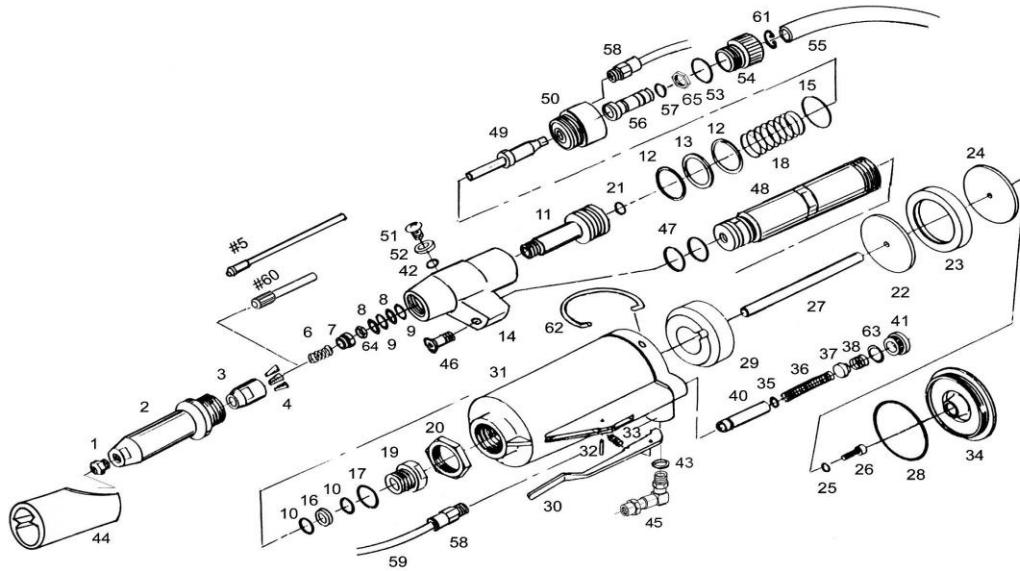

## TECHNICAL DATA

Blind Rivet Setting Capacity	Max. 3/16"(4.8mm)blind rivets in all mat
Min Hose inch	3/8
Traction Power lbs(kgf)	2000(900)
Operating Air Pressure PSI	90
Net Weight lbs(kgs)	3.3(1.5)
Stroke Length inch(mm)	(16)

## PARTS LIST

Index #	Part #	Description	Quantity	Index #	Part #	Description	Quantity
1C	ZIR316-01C	3/16" Nosepiece	1	38	ZIR316-38	Valve Pressure Spring	1
2	ZIR316-02	Head	1	40	ZIR316-40	Valve Tube	1
3	ZIR316-03	Jaw Housing	1	41	ZIR316-41	Screw Plug	1
4	ZIR316-04	Jaws	3	42	ZIR316-42	O-Ring	1
6	ZIR316-06	Spring	1	43	ZIR316-43	Sealing Washer	1
7	ZIR316-07	Jaw Housing Coupler	1	44	ZIR316-44	Rubber Sleeve	1
8	ZIR316-08	X-Ring Seal	2	45	ZIR316-45	Swivel Jointer	1
9	ZIR316-09	O-Ring Washer	2	46	ZIR316-46	Bolt	1
10	ZIR316-10	O-Ring Seal	2	47	ZIR316-47	O-Ring Seal	2
11	ZIR316-11	Hydraulic Plunger	1	48	ZIR316-48	Hydraulic Pipe	1
12	ZIR316-12	O-Ring Seal	2	49	ZIR316-49	Tube Screw	1
13	ZIR316-13	O-Ring Washer	1	50	ZIR316-50	Screw Plug	1
14	ZIR316-14	Hydraulic Cylinder	1	51	ZIR316-51	Oil Plug	1
15	ZIR316-15	O-Ring Seal	1	52	ZIR316-52	Washer	1
16	ZIR316-16	O-Ring Washer	2	53	ZIR316-53	O-Ring	1
17	ZIR316-17	O-Ring Seal	1	54	ZIR316-54	Regulator	1
18	ZIR316-18	Hydraulic Return Spring	1	55	ZIR316-55	Tube (ψ8 x 7FT)	1
19	ZIR316-19	Hydraulic Rod Guide	1	56	ZIR316-56	Nipple	1
20	ZIR316-20	Lock Nut	1	57	ZIR316-57	O-Ring Seal	1
21	ZIR316-21	O-Ring	1	58	ZIR316-58	Tube Connector	2
22	ZIR316-22	Front Piston Head Disc	1	59	ZIR316-59	Tube (ψ2.5)	1
23	ZIR316-23	Piston Head Packing Ring	1	60	ZIR316-60	Pusher Tube	1
24	ZIR316-24	Rear Piston Head Disc	1	61	ZIR316-61	Retaining Ring	1
25	ZIR316-25	Spring Washer	1	62	ZIR316-62	Handing Ring	1
26	ZIR316-26	Piston Head Lock Screw	1	63	ZIR316-63	O-Ring Seal	1
27	ZIR316-27	Plunger Rod	1	64	ZIR316-64	Nut	1
28	ZIR316-28	O-Ring Seal	1	65	ZIR316-65	Nut	1
29	ZIR316-29	Damping Ring	1	<b>ACCESSORIES</b>			
30	ZIR316-30	Trigger Arm	1	ZIR316-1A	1/8" Nosepiece	1	
31	ZIR316-31	Air Cylinder Body	1	ZIR316-1B	5/32" Nosepiece	1	
32	ZIR316-32	Roll Pin	1	ZIR316-04	Jaws (3)	3	
33	ZIR316-33	Spring	1	ZIR316-05	Pusher Tube	1	
34	ZIR316-34	Air Cylinder Cap	1	ZIR316-A01	Hex Wrench	1	
35	ZIR316-35	O-Ring Seal	1	ZIR316-A02	Spanner 11mm/13mm	1	
36	ZIR316-36	Valve Spring	1	ZIR316-A03	Spanner 14mm/17mm	1	
37	ZIR316-37	Valve Plate	1	ZIR316-A04	Oil Syringe	1	