

Manganin Shunt Resistor

for High Precision Current Measurement

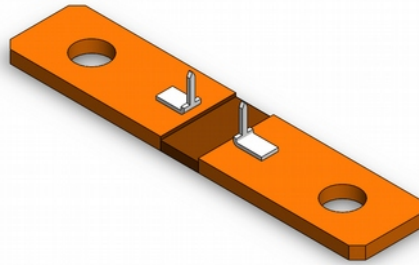

Description

The R100-BAR-03B shunt resistor is a precision Cu-Mn resistance. It consists of a copper busbar with hole terminals for easy installation and solderable pin-type sense contacts.

The shunt is designed for precision current measurement with high thermal stability in instruments, industrial, and automotive applications, typically including energy meters, ampere meters, power inverters, and battery current monitoring.

Characteristics

Parameter	Typical Value	Unit
Resistance	100 (*)	μOhm
Accuracy of absolute resistance	5	%
Resistivity temperature coefficient	± 50	ppm/K
Operation temperature range	-50 ... 150	$^{\circ}\text{C}$
Continuous power	7	W
Maximum power	36	W
Inductance	<5	nH

(*) available resistance values: $50\mu\text{Ohm}$, $75\mu\text{Ohm}$, ..., $250\mu\text{Ohm}$

Geometry

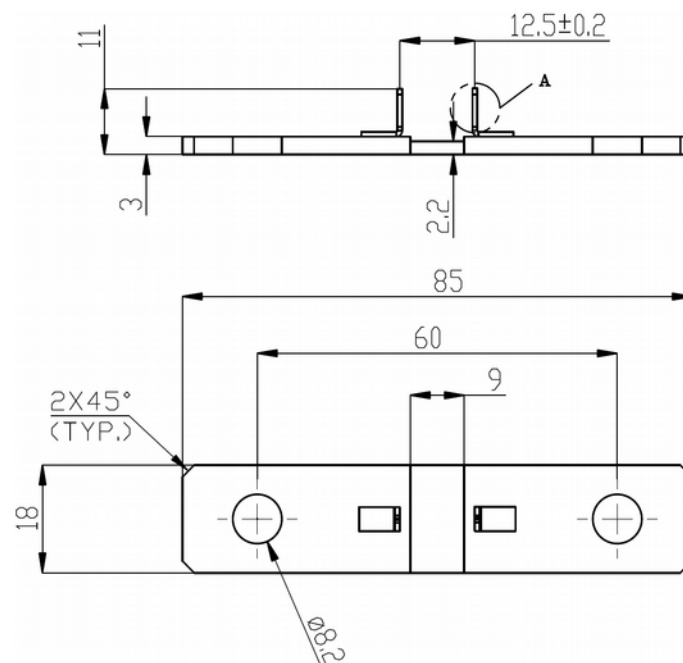

Please contact us at



maglab GmbH

Güterstrasse 141
CH-4053 Basel
Switzerland

+41 61 261 16 44
info@maglab.ch
www.maglab.ch



Permanent Magnets Ltd.

B-3, MIDC Industrial Area, Mira-gaon
Miraroad-East, Thane-401104, Maharashtra
India

+91 22 62 16 54 00
shuntinquiry@pml.in
www.pmlindia.com