



1

Dieroom Equipment



2

Dieroom Supplies



3

Steel Rule



4

Wagner Punches



5

***Ejection Materials
Adhesives & Glues***



6

***Channel® Creasing
Matrix & Tools***



7

***Diecutting &
Makeready Supplies***

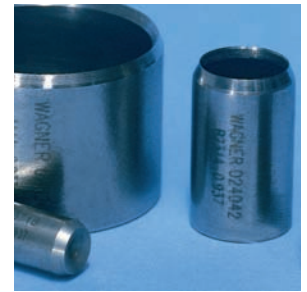
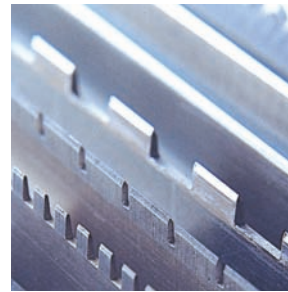
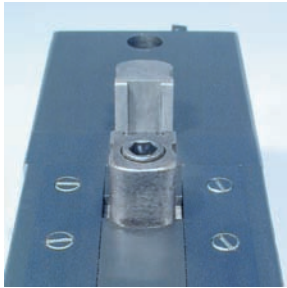

1 Dieroom Equipment

Pages 1-3

Benders, notchers, miters, cutters, jig saws, rule processors, power equipment and more...

2 Dieroom Supplies

Pages 4-17

Dieboard, jig saw blades, drills, pins, Centerline products, mallets, pullers, sharpeners, scribes, die film, carbon paper, fasteners, nicking tools, stripping products and more...

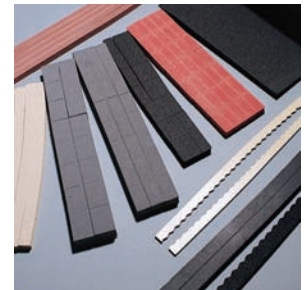

3 Steel Rule

Pages 18-37

Cutting, creasing, perforating, rotary/serrated, combinaton cut/crease, wave, tear edge (zipper), coated, pre-nicked and more...



4 Wagner Punches

Pages 38-44

Standard tube, feed-thrus, self-cleaning, ovals, notched, serrated, cross cuts, cups, pin points, seamless hangers, squares, rule connectors, custom-milled and more...



5 Ejection Materials Adhesives & Glues

Pages 45-50

Open cell, closed cell, gum, cork, special shapes, profile rubber, Grip N' Strip, SuperSet and more...

6 Channel® Creasing Matrix & Tools

Pages 51-54

Metal-based matrix, Marathon Matrix™, Plastrix, straight and miter cutters, shim tapes, plate cleaner and more...

7 Diecutting & Makeready Supplies

Pages 55-60

Guides, quoins, wood furniture, counterboard material, stop pins, specialty knives, cutting plates, cutting jackets, makeready tape, stripping tools and more...

FOR PRODUCT INFORMATION AND ORDERS CONTACT:

CCM Die Supply • Martinsburg, WV
800 451-7373 • Fax 866-708-4686

CCM Die Supply • Woodbridge, CT
800 451-7373 • Fax 866-708-4686

CCM Die Supply • Tucker, GA
800 972-2601 • Fax 866-908-9418

email: sales@ccmdie.com

Wagner Super Side Gauge



Super Side Gauge Set - Shown with optional 2" micrometer.

FW&SON
Frank Wagner & Son

The Super Side Gauge is designed to improve on the standard side gauge used on die equipment. Features include quick operating knobs rather than thumb screws, 1/2" diameter bars (rather than 3/8") to reduce flex, and a 10" or 18" (specify when ordering) base bar. Options include a 2" micrometer for added accuracy and stop rings for multiple sets.

Part #	Application
#001	Helmold Benders, Standard and Bendall, Notchers and Miter
#002	Wagner Bender, Notcher, Delta and Plain Trimmer, Helmold 2" Cutter
#003	Helmold 1-1/2" Cutter, Helmold 2" Cutter
#003A	With square hole for Helmold Cutters (does not come with square bar)

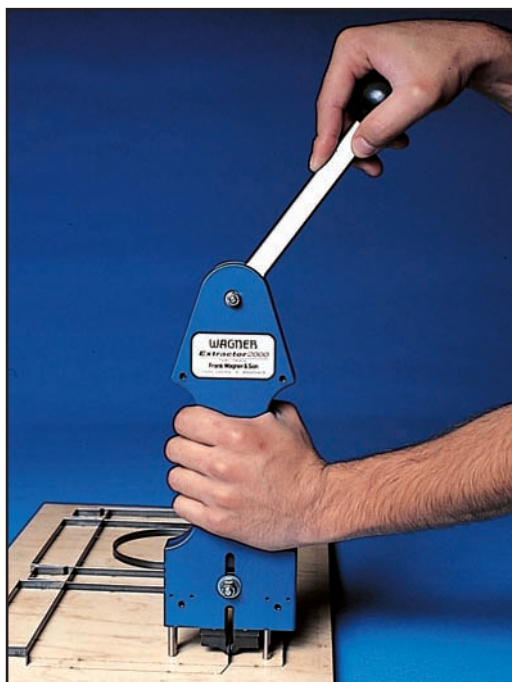

WAGNER Extractor 2000

Extractor 2000 is the ultimate hand operated rule puller. Easy to use, keeps knuckles safely away from steel rule die. Smooth lever action generates up to 600 lbs. of pulling power. Extractor 2000 pulls rule straight up, saving kerf and minimizing wear and tear on die boards. U.S. Patent #D363964.

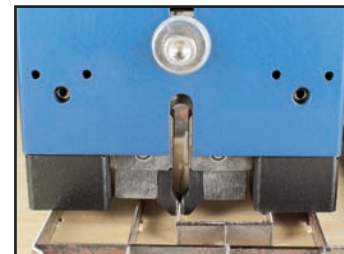
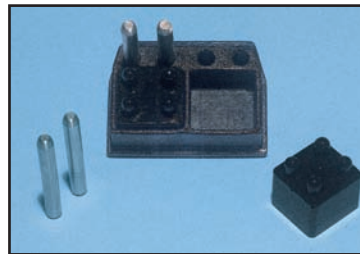

Tool caddy, foot pins and polyurethane foot pads are included with both Extractor 2000 and Extractor 3000.

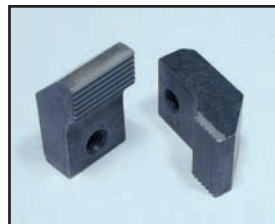

Original replacement jaws.



Optional "cut-down" version, jaws relieved on the back and sides.

EXCLUSIVE

Both Wagner Extractors feature replaceable jaws. Easy to install, they are available in the original width or the optional "cut-down" version for close proximity rule layouts.



WAGNER Extractor 3000

With the same versatile features as the Extractor 2000, the Extractor 3000 takes rule pulling one step further with the added convenience of smooth, adjustable pneumatic power. Pulling power is adjustable, and the Extractor 3000 can be used with a balancer to reduce fatigue. Easy push-button operation, comfortable grip and multi-position pins/foot pads provide accurate and safe rule pulling.

FOR PRODUCT INFORMATION AND ORDERS CONTACT:

CCM Die Supply • Martinsburg, WV
800 451-7373 • Fax 866-708-4686

CCM Die Supply • Woodbridge, CT
800 451-7373 • Fax 866-708-4686

CCM Die Supply • Tucker, GA
800 972-2601 • Fax 866-908-9418

email: sales@cmdie.com

Helmold Bender Bendall

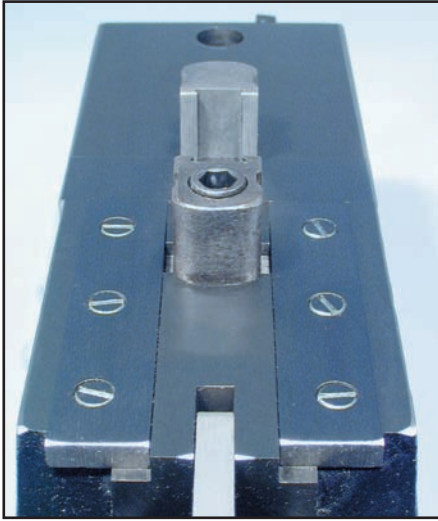

Also available in Standard, Heavy Duty and E-Z Bender Models.

Helmold Rule Cutter

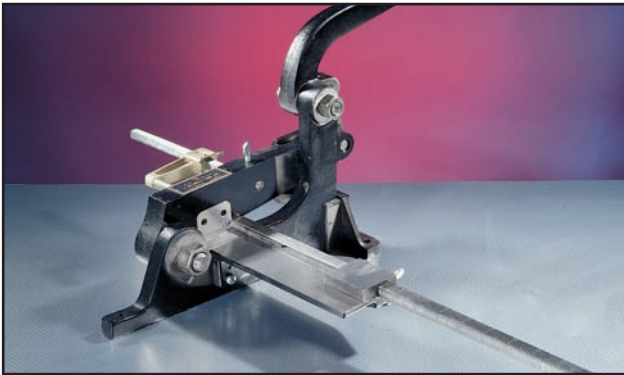

Standard model for 1-1/2" steel rule. 2-1/8" and 2-7/8" models are also available.

Dimple Die

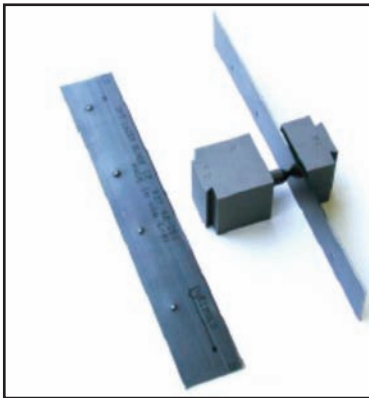

THE "DIMPLE DIE"

- Produces consistent "dimples" in rule to compensate for loose kerf.
 - Dies fit all standard Helmold benders.
 - Easily replaceable, long wearing dimple pin.
- A quick, effective solution for loose kerf. Replaceable dimple pins are available.

HELMOLD

From rule cutters, to benders and notchers to automated processing equipment, Helmold has it all. All designed and manufactured with quality and value, Helmold equipment remains as an industry standard.

Helmold Standard Notcher

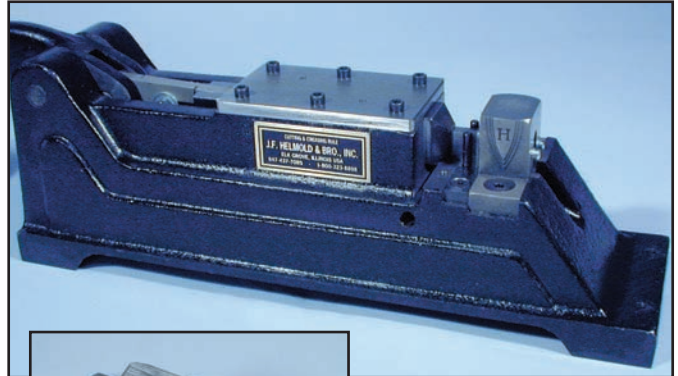

Also available in Heavy Duty 2-hole and 4-hole models.

Female Narrow House for Helmold Standard Notcher allows for notching of pre-bent rule.

Helmold Right & Left Hand Miter



Available also in a Single Miter model.

FOR PRODUCT INFORMATION AND ORDERS CONTACT:

CCM Die Supply • Martinsburg, WV
800 451-7373 • Fax 866-708-4686

CCM Die Supply • Woodbridge, CT
800 451-7373 • Fax 866-708-4686

CCM Die Supply • Tucker, GA
800 972-2601 • Fax 866-908-9418

email: sales@cmdie.com



Helmold Power Assist Notcher & Bender

Based on Helmold's E-Z Heavy Duty Notcher and the E-Z Heavy Duty Bender, these machines are capable of bending up to 4 pt. rule and notching up to 6 pt. rule. Each is pneumatically assisted to provide the power to effortlessly notch and bend rule. Sold as complete units, they are designed to use standard Helmold bender dies and notching knives.



Helmold's Cutawl Saw



The Cutawl easily and accurately cuts curved rotary boards, flat dieboards and stripping boards made of maple and birch. Three models are available (see below). Cutawl saw blades are available in 2, 3 and 4 pt.

Model #	Recommended Use
K-12F	Flat dieboards
K-12C-66	66" rotary dieboards
K-12C-50	50" rotary dieboards

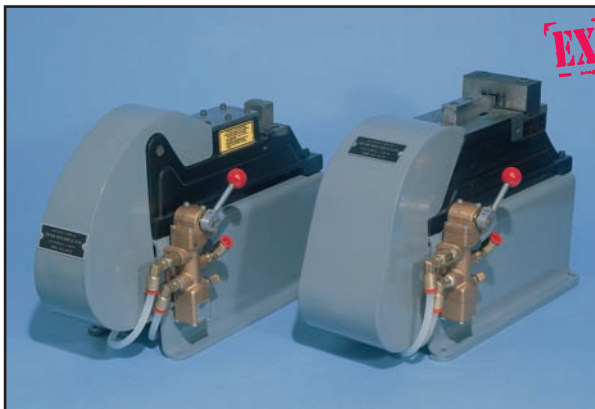

EXCLUSIVE



The Pneu-Notcher system **easily converts your existing Helmold notcher to speedy Pneumatic Action!** Compressed air does the hard work! All you do is simply push the small lever forward and pull it back, to get a quick, clean notch.

Model #	Conversion for:
PNHD	Helmold Heavy Duty Notchers (2 or 4 hole model)
PNSTD	Helmold Std. Notcher and Miters (2 & 3 pt.)
PNWAG	Wagner Notcher and Delta Trimmer (2 & 3 pt.)

FOR PRODUCT INFORMATION AND ORDERS CONTACT:

CCM Die Supply • Martinsburg, WV
800 451-7373 • Fax 866-708-4686

CCM Die Supply • Woodbridge, CT
800 451-7373 • Fax 866-708-4686

CCM Die Supply • Tucker, GA
800 972-2601 • Fax 866-908-9418

email: sales@ccmdie.com

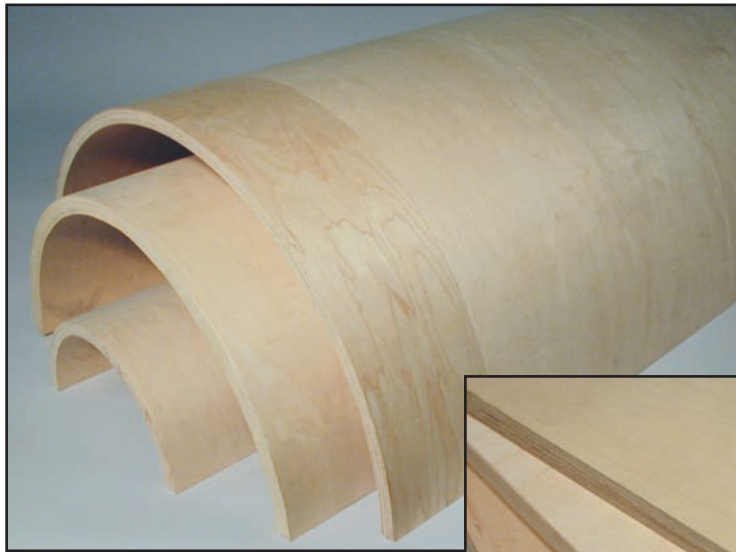

Rotary Dieboard

Available in 1/2" and 5/8" thicknesses.
 Diameters: 7-1/2" to 19-3/16"
 Larger sizes available as special orders.

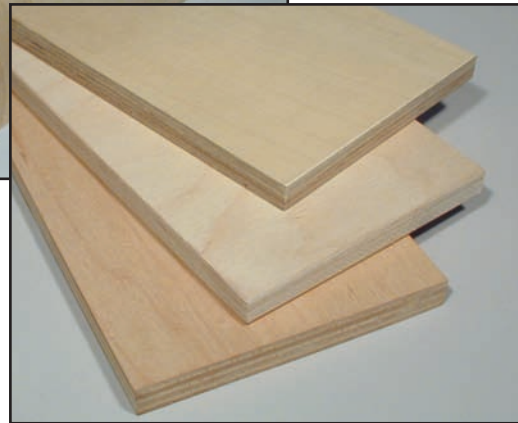

Dieboard

Flat - available in Birch, Maple and Beech. Rotary Curved - available in Maple and mixed core. 100% laser compatible.

Flat Dieboards

Imported Finland Birch

3/8" thick board sizes: 48" x 72", 60" x 60"

5/8" thick board sizes: 36" x 48", 48" x 48", 48" x 60", 60" x 60", 60" x 96"

3/4" thick board sizes: 36" x 48", 48" x 48", 48" x 60", 48" x 72"

Hard Rock Maple

3/8" thick board sizes: 24" x 36", 36" x 48", 48" x 60"

1/2" thick board sizes: 36" x 48", 48" x 60", 48" x 72"

5/8" thick board sizes: 24" x 36", 36" x 48", 48" x 60", 48" x 72"

3/4" thick board sizes: 24" x 36", 36" x 48", 48" x 60"

Beech

16 mm (5/8") thick board sizes: 48" x 72", 48" x 60" laser compatible.

13 mm (1/2") thick board sizes: 48" x 72", 48" x 60" laser compatible.

Other sizes available on all board types.

Rayform Dieboards

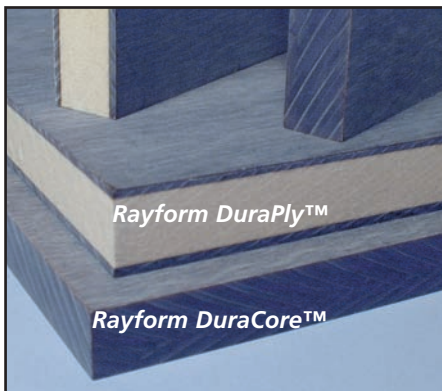

- Rayform Duracore™
- Rayform Duraply™
- Rayform Rotary

The **Rayform** family of dieboards lead the industry in strength, dimensional stability, long run dies, extended rule life and re-knifing. They are virtually warp free, impervious to moisture, can withstand high temperatures and will not delaminate.

Rayform dieboards are laser-compatible, but can be sawed or machine cut. A special rayform 5/16" thick Duraply™ is specially made for use on the Gerber Profile machine.

Rayform DuraPly™ has an inner construction of Medium Density Fibers (MDF) which is laser compatible. Extremely flat and stable and more economical than Rayform DuraCore™. **Rayform DuraCore™** is a solid Rayform board, **Rayform Rotary** dieboard features a plywood core.

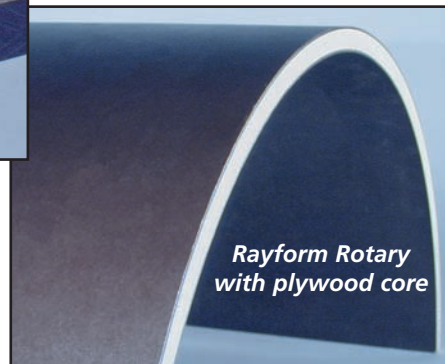

PolyLam Birch Dieboard



PolyLam Birch is a Finnish Birch with a face grade of BB/BB. It is laminated with .010 industrial laminate on both sides. The result is a board that won't delaminate, peel, chip or break and resists warping, twisting, and moisture. Can be laser cut, and provides exceptional strength, stability and rule-holding power.

FOR PRODUCT INFORMATION AND ORDERS CONTACT:

CCM Die Supply • Martinsburg, WV
 800 451-7373 • Fax 866-708-4686

CCM Die Supply • Woodbridge, CT
 800 451-7373 • Fax 866-708-4686

CCM Die Supply • Tucker, GA
 800 972-2601 • Fax 866-908-9418

email: sales@ccmdie.com



Spur & Multi-Spur® Drill Bits

Spur Drills

Sizes Available	Sizes Available
5/32"	25/64"
3/16"	13/32"
7/32"	7/16"
1/4"	29/64"
17/64"	15/32"
9/32"	1/2"
19/64"	9/16"
5/16"	5/8"
11/32"	11/16"
3/8"	3/4"

Multi-Spur® Machine Bits

Sizes Available		Sizes Available	
IN.	MM.	IN.	MM.
13/16	20.6	1-7/16	36.5
7/8	22.2	1-1/2	38.1
15/16	23.8	1-9/16	39.7
1	25.4	1-5/8	41.3
1-1/16	27.0	1-11/16	42.9
1-1/8	28.6	1-3/4	44.5
1-3/16	30.2	1-13/16	46.0
1-1/4	31.8	1-7/8	47.6
1-5/16	33.3	1-15/16	49.2
1-3/8	34.9	2	50.8

1/2" Shank on both style bits.
Other sizes available upon request.

7 piece Spur Bit Set



Set includes 1/8", 3/16", 1/4", 5/16", 3/8", 7/16" & 1/2" Spur Drill Bits. Bits fit any drill with 3/8" or larger chuck

Jig Saw Blades

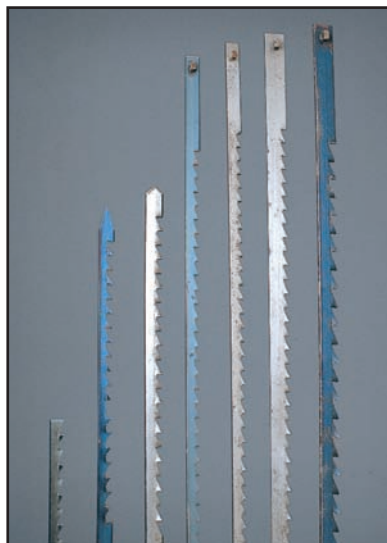

Available for the following saws:

- RICHARDS • LABORSABER
- SABERMATIC • SANDVIK
- CUTAWL
- Blades with and without pins - 1-1/2, 2, 3, 4 and 6 pt.
- Retractable style blades - 2, 3, 4 and 6 pt.
- Reverse Tooth blades - 2 and 3 pt.
- Blade Guides available for all RICHARDS, LABORSABER or SABERMATIC saws.
- CUTAWL blades available in 2, 3, and 4 pt. sizes.

Die Maker's Apron



Hand-stitched in denim, durable, washable, features two pockets and attached heavy duty tie.

FOR PRODUCT INFORMATION AND ORDERS CONTACT:

CCM Die Supply • Martinsburg, WV
800 451-7373 • Fax 866-708-4686

CCM Die Supply • Woodbridge, CT
800 451-7373 • Fax 866-708-4686

CCM Die Supply • Tucker, GA
800 972-2601 • Fax 866-908-9418

email: sales@ccmdie.com



FROM LEFT TO RIGHT: P-100, P-102A, P-102, P-101, P-104 and P-132.

Aluminum Retractable Pins

Part #	Steel Pin Diameter	Barrel Dimensions	Travel
P-100	1/8"	1/4" dia. x 5/8" long	1/4"
P-101	1/8"	1/4" dia. x 1" long	9/16"
P-102	1/8"	1/4" dia. x 3/4" long	1/2"
P-102A	1/8"	1/4" dia. x 3/4" long	1/4"
P-104	1/8"	1/4" dia. x 1-1/4" long	13/16"
P-132	1/4"	11/32 dia. x 3/4" long	7/16"

These quality pins are used for locating and registering parts, mainly used in the blister packaging industry.



FROM LEFT TO RIGHT: WPRP .250, WPRP .187, WPRP .156 and WPRP .125.

Steel Registration Pins

Part #	Brass Base	Steel Pin
WPRP .125	.250 diameter	.124 diameter
WPRP .156	.250 diameter	.156 diameter
WPRP .187	.312 diameter	.187 diameter
WPRP .250	.375 diameter	.250 diameter

These brass-barreled, tapered steel pins are manufactured to tight tolerances for close registration work.

Stripping Pins



Spring Pins - Packaged in 1,000 quantities. Sizes: 1/8", 3/16", 1/4" or 3/8" diameter by 2" long. Used as stripping pins.



Inca Nail Pins 50 mm. long, 500 per package.

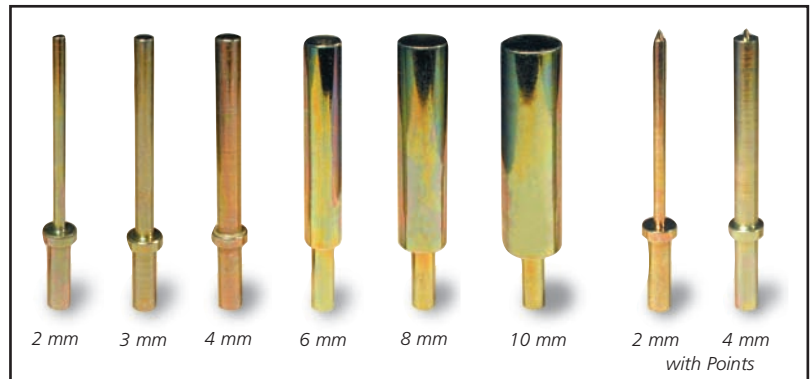

Stripping Pins available in the sizes and styles shown above. 50 mm tall (2"). All base sizes are the same size (4mm) for consistent drilling and laser cutting of holes.

FOR PRODUCT INFORMATION AND ORDERS CONTACT:

CCM Die Supply • Martinsburg, WV
800 451-7373 • Fax 866-708-4686

CCM Die Supply • Woodbridge, CT
800 451-7373 • Fax 866-708-4686

CCM Die Supply • Tucker, GA
800 972-2601 • Fax 866-908-9418

email: sales@cmdie.com

Centerline Products

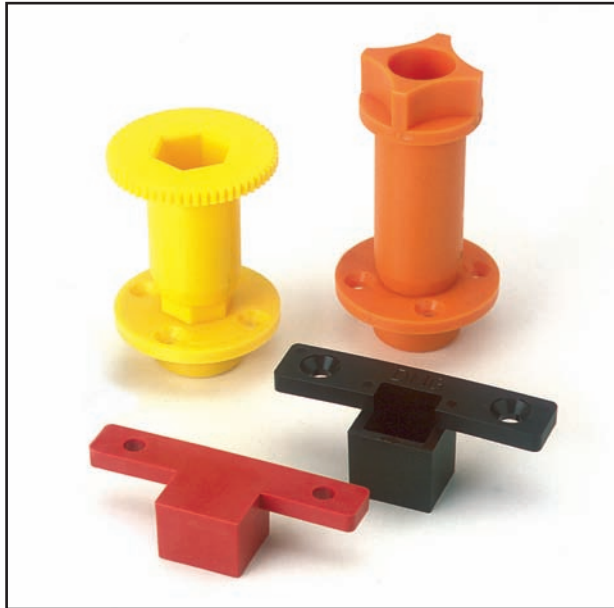

Clockwise - Yellow and Orange Storage Bolt and Centering Nut, Black Centering Stop for Upper Stripper, and Red Centering Stop for Female Stripper. Orange Storage Nut and Bolt available as a set or can be ordered separately.

EXCLUSIVE

As speeds increase in the diecutting process on Bobst diecutting presses, so does the stripping of the rear and lateral waste. With these increased speeds, accuracy becomes more critical. Bobst designed the Centerline System to achieve stripping accuracy at higher press speeds.

Distance Spacers



Sizes available: 7/8", 1" and 1-1/8"
(measure is of the spacer section only, does not include insert ends.)

Stop Plate



Adapts older tools to the Centerline System. Placed at the front of one or more of the reinforcements, to support the front of the board.

Clamping Jaws

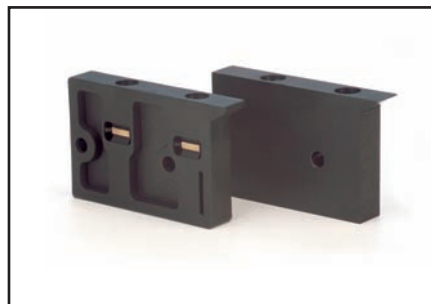

Left plastic, right steel. Economical enough to keep with stripping die.

Separating Knives

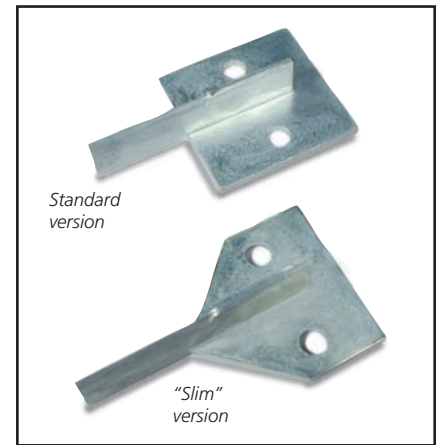

Separating knives, in the above styles, are required and fixed on the female stripping board. No dieboard slots are necessary with these styles of separating knives.

Unthreaded T-Nut



Used as a sleeve for the tapered bolt that mounts the cutting die to the chase.

Strengtheners



Keep die corners sharper and helps make dies run longer.

Centering Bracket



For Bobst 103 and 104 machines, used for fast lock frames.

FOR PRODUCT INFORMATION AND ORDERS CONTACT:

CCM Die Supply • Martinsburg, WV
800 451-7373 • Fax 866-708-4686

CCM Die Supply • Woodbridge, CT
800 451-7373 • Fax 866-708-4686

CCM Die Supply • Tucker, GA
800 972-2601 • Fax 866-908-9418

email: sales@ccmdie.com



Elastomer Mallets

These heavy-duty mallets are made of advanced Elastomer Resin for durability and toughness. Long lasting, replacement heads are available and heads can be turned to maximize usage.

Product #	Mallet Description	Weight
#4	2" dia. x 3-1/2" long head	11 oz.
#4L	2" dia. x 5" long head	14 oz.
#5	2-3/4" dia. x 4-1/4" long head	22 oz.
#6	2-3/4" dia. x 4-3/4" long head	24 oz.

Replacement Heads for Elastomer Mallets are available in all sizes.



Rawhide Mallets

A popular, low cost mallet used in most die shops. Loaded style heads also available, inquire when ordering.

Product #	Mallet Description	Weight
#3	1-3/4" dia. head x 3-3/8" long	11 oz.
#4	2" dia. head x 3-1/2" long	14 oz.
#5	2-3/4" dia. head x 4-1/2" long	22 oz.
#6	2-3/4" dia. head x 4-3/4" long	24 oz.



Urethane Mallets

These moderately priced mallets feature tough molded Urethane heads.

Product #	Mallet Description	Weight
#4	Orange - 1-7/8" diameter head	11 oz.
#2x5	Black - 1-7/8" x 5" long head	14 oz.
#5	Black - 2-1/2" diameter head	22 oz.

The large #5 urethane mallet is excellent for rotary, clicker and any other heavy rule applications.

FOR PRODUCT INFORMATION AND ORDERS CONTACT:

CCM Die Supply • Martinsburg, WV
800 451-7373 • Fax 866-708-4686

CCM Die Supply • Woodbridge, CT
800 451-7373 • Fax 866-708-4686

CCM Die Supply • Tucker, GA
800 972-2601 • Fax 866-908-9418

email: sales@cmdie.com



Bar-Plate Precision Diemaker's Hammer



Bar-Plate's Precision Diemaker's Hammer provides three distinct work heads, a traditional-style mallet head with two different diameter faces. Plus a rule taper face at the end of the handle. All faces are replaceable.

Bar-Plate Rule Setter

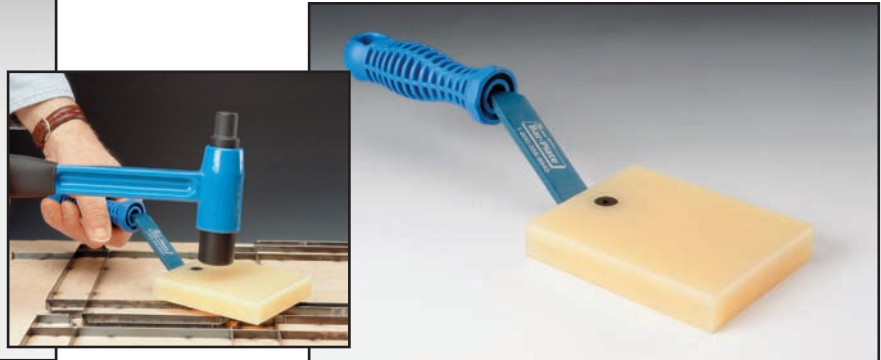

The Rule Setter drives steel rule sections into the dieboard undamaged, perfectly seated and level. Especially effective in die configurations that use a number of small pieces of steel rule in a small area.

Bar-Plate Rule Tamper



The Rule Tamper is a unique steel rule insertion tool that combines the benefits of dead blow, bounce-free, low impact action.

Bar-Plate Rule Tweaker



Bar-Plate's Tweaker is the safe and simple way to correct knife distortion in a die. It's interchangeable handle can be used with any of the four available heads, in either 2 or 3 pt. versions (as shown above).

DieMakers Mallet



Sandvik's 450 Diemakers Hammer is specially designed for knifing steel rule dies. It features an aluminum head with replaceable plastic faces (below).



FOR PRODUCT INFORMATION AND ORDERS CONTACT:

CCM Die Supply • Martinsburg, WV
800 451-7373 • Fax 866-708-4686

CCM Die Supply • Woodbridge, CT
800 451-7373 • Fax 866-708-4686

CCM Die Supply • Tucker, GA
800 972-2601 • Fax 866-908-9418

email: sales@ccmdie.com

Extractor 2000

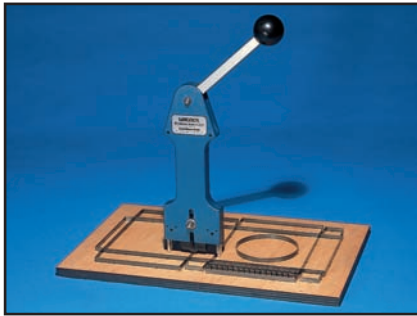

- Pulls rule straight up, does not damage kerf.
- Interchangeable foot pins and pads.
- Easy to operate by both right and left handed users.
- Low-cost replacement jaws are easy to replace.
- Can be used on rotary or flat dies.
- Pulls up to 1-1/2" high rule 6 pt. thickness.
- Hands are kept safely away from rule when pulling.

U.S. Patent #D363964

EXCLUSIVE

FW&SON
Frank Wagner & Son



Extractor 3000



- Similar to Extractor 2000 - but with Pneumatic Power!
- Designed for use with a balancer to reduce fatigue.
- Adjustable air pressure to control pulling action.
- Low-cost replacement jaws are easy to replace.
- Easy push button operation - let compressed air do the work!
- Generates up to 600 lbs. of pulling power.

See page 2 for additional information on Extractor features.

Sandvik Pneumatic Rule Puller

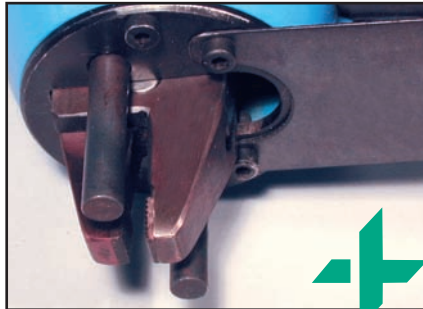

Sandvik's 50-0-HD rule puller (left), and close-up of jaws (right).



Sandvik's 50-0 and 50-0-HD pneumatic rule pullers safely and efficiently extract rule up to 2" in height from both rotary and flat dies. The 50-0 and the heavy duty 50-0-HD (2 to 3 times the pulling power) models pull rule straight up, reducing wear on the dieboard kerf. Both units feature smooth pneumatic operation, and unique double-action that allows the jaws to grip the rule, then the pins fire down to provide lifting power.

Bar-Plate



A rugged puller, alloy steel, heat treated, lifts rule as close as 1/4". Provides powerful grip and leverage.

Helmold



8-1/4" long, 1" wide jaws, 5/8" deep throat features a double-action grip.

Channellock



Standard, inexpensive pullers. Available in the following lengths: 14", 10", 8", 7" and 6".

FOR PRODUCT INFORMATION AND ORDERS CONTACT:

CCM Die Supply • Martinsburg, WV
800 451-7373 • Fax 866-708-4686

CCM Die Supply • Woodbridge, CT
800 451-7373 • Fax 866-708-4686

CCM Die Supply • Tucker, GA
800 972-2601 • Fax 866-908-9418

email: sales@cmdie.com

Rule Sharpeners



CCM Die Supply stocks three different models, (left to right) the "Super Sharpener", the Economy style and the Sharpy Rule Sharpener. Recommended for use on dies which cut into a cutting pad. Should be used only to touch-up rule to help complete a cutting job.

Hand Rule Cutter



This inexpensive rule cutter is designed to cut 2 and 3 PT. rule. Great for cutting coil stock and anywhere a bench cutter is not available.

Pocket Scribes



#81 - 3/8" diameter Pocket Scribe 5-7/8" overall length.
 #83 - 1/4" diameter Pocket Scribe 4-3/4" overall length.
 Replacement points available for both #81 and #83 scribes.
 #88 - Carbide point scribe with pocket clip.

Wagner Blister Buster



Protect your hands and arms from the shock of your die making equipment. Blister Buster snaps on easily to the handle of most bench machine in seconds. Absorbs moisture and insulates against the cold. Made of durable molded foam with a washable polyester cover.

Kevlar® Safety Gloves



These woven safety gloves are ideal for ruling and re-ruling dies. Made from Dupont® Kevlar® fibers that are five times stronger than steel - the same fibers used in bullet-proof vests! Cut, slash and abrasion resistant. Available in regular and fingerless styles with PVC dots for a sure grip. Lightweight gloves also available.

FOR PRODUCT INFORMATION AND ORDERS CONTACT:

CCM Die Supply • Martinsburg, WV
 800 451-7373 • Fax 866-708-4686

CCM Die Supply • Woodbridge, CT
 800 451-7373 • Fax 866-708-4686

CCM Die Supply • Tucker, GA
 800 972-2601 • Fax 866-908-9418

email: sales@ccmdie.com

Die Matte™ Film



Mylar film, frosted (matted) on one side. Available in .003 to .007 thicknesses. Also available frosted (matted) on both sides. Other thickness available upon request. **Also available Ink Jet Film.** Widths available are 36", 42" and 54". Roll lengths available in 20yd, 50yd and 100yd.

Carbon Paper

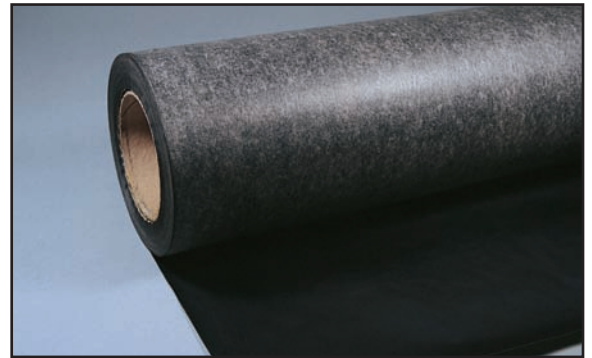

Black, one-time use carbon paper. Packaged in rolls .0015 x 44" wide in convenient 1,000 or 500 foot rolls.

Type Perf and Mini Perf

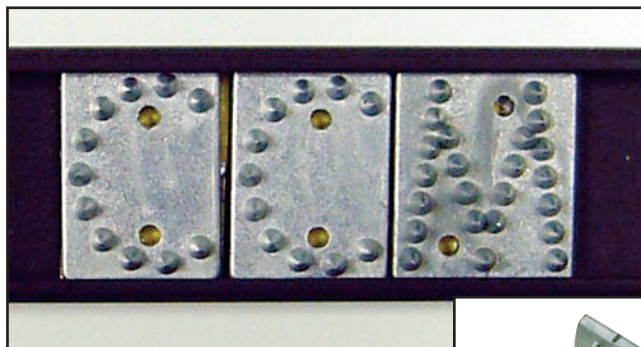

Type Perf is designed for use with corrugated cutting dies. 3/4" letters on a 1" base – 6 of the same character per bag. Letters: A-Z, numbers: 0-9, punctuation: "!", "-", "...". Recycled logo sold individually. Track is optional and is available separately in 30" strips. Type perf is available with or without adhesive backing.



Mini Perf is designed for use in Micro-Flute corrugated material. 3/8" letters and numbers on a 1/2" base, all characters and end pieces sold individually. Mini recycled logo available and sold separately.

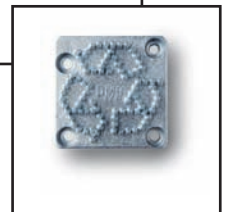

Mini Perf must be mounted in track with end pieces and nail as seen above. Track is sold in 30" strips.

Economy Track for Type Perf



Black vinyl, sold in six foot lengths, easy to cut with shears. Will work with all makes of perforated type with a 1" base (3/4" tall characters). For use with 5/8" wood. Available in 6" lengths.

Yellow Track for Type Perf

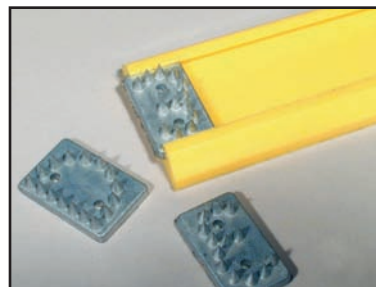

Yellow vinyl, heavier duty than Economy Track, sets type up taller due to the thicker base. Works with all brands of 1" base perf characters. For use with 1/2" thickness wood. Available in 5" lengths.

FOR PRODUCT INFORMATION AND ORDERS CONTACT:

CCM Die Supply • Martinsburg, WV
800 451-7373 • Fax 866-708-4686

CCM Die Supply • Woodbridge, CT
800 451-7373 • Fax 866-708-4686

CCM Die Supply • Tucker, GA
800 972-2601 • Fax 866-908-9418

email: sales@cmdie.com

Corrugated Fasteners and Installation Tools

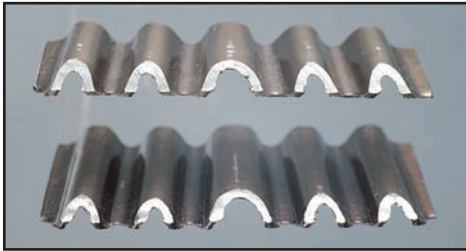

Available in 3/8" and 1/2" sizes. Used to fasten two pieces of die board together to construct larger steel rule dies.

Corrugated Fastener Hand Tool

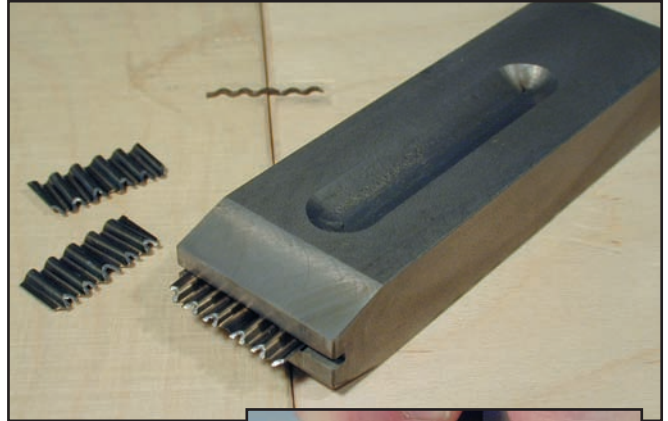

Corrugated fastener insertion tool holds fasteners securely and keeps fingers away from head of hammer.

Corrugated Joint Fastener Tool



Pneumatically-powered, uses clips of 3/8" or 1/2" chisel point fasteners. Loads like a stapler for quick and easy joining of dieboards. Fasteners sold separately in boxes of 5,000.

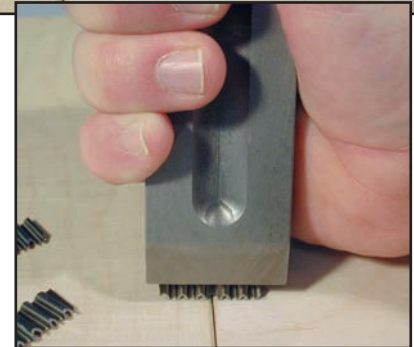
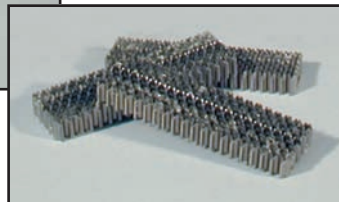

Pinch Dogs



Used to hold dieboards tight while inserting corrugated fasteners. Can also be used to secure rotary dieboards together when being bolted to drum. 2" long x 1-1/2" high.

T-Nuts



Sizes available: 8-32, 10-24, 10-32, 1/4-20 and 5/16-18, and in metric sizes of 4 mm. and 8 mm. 500 per box.

Die Bolts

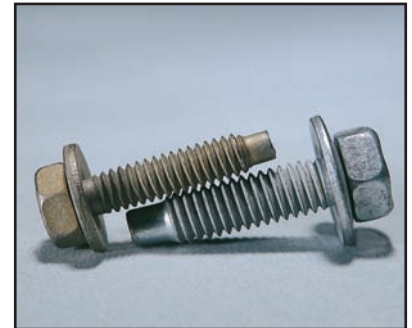

Sizes available: 1/4" x 1-1/8" and 5/16" x 1-1/4" packaged in quantities of 100, with attached washers.

FOR PRODUCT INFORMATION AND ORDERS CONTACT:

CCM Die Supply • Martinsburg, WV
800 451-7373 • Fax 866-708-4686

CCM Die Supply • Woodbridge, CT
800 451-7373 • Fax 866-708-4686

CCM Die Supply • Tucker, GA
800 972-2601 • Fax 866-908-9418

email: sales@ccmdie.com

Quicknick Grinders



Quicknick Grinder Pneumatic version.



Quicknick Grinder - 110 V version.



Grinding wheels for Quicknick grinders in .006, .008, .012, .016, .020, .025, .031, .047, .063, .078, .094, .109, .125 and 1.0 mm thicknesses are included with grinders.

These versatile nicking grinders produce clean, perpendicular nicks at consistent, adjustable depths. Each comes complete with a set of 10 grinding wheels in various sizes. 14,000 R.P.M. maximum, Quicknick Grinders are available in 110 V, 220 V, and Pneumatic powered versions.

Servo Grinders & Wheels

SWISS MADE BY **SERVO**® HANDELS & WERBE AG

SERVO Super Quick Grinder



Available in both battery powered, or 110 V powered models, as pictured above.

Grinding Disk for SERVO Grinders

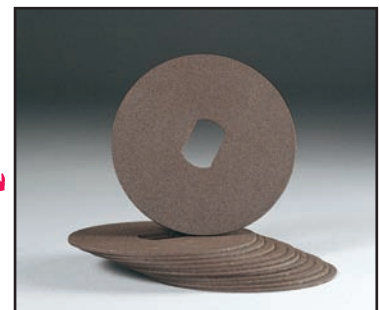

Wheels are available in .03mm to 2.0mm thicknesses.

EXCLUSIVE

SERVO Super Quick grinders and wheels allow for systematic nicking of steel rule, with optimum quality results.

Other SERVO equipment includes: The SERVO Mega-Form, Mini Servo, Baby Servo, Torque Leader and the SERVO Tornado (waste stripper). See these products in the Diecutting Equipment section of this catalog.

FOR PRODUCT INFORMATION AND ORDERS CONTACT:

CCM Die Supply • Martinsburg, WV
800 451-7373 • Fax 866-708-4686

CCM Die Supply • Woodbridge, CT
800 451-7373 • Fax 866-708-4686

CCM Die Supply • Tucker, GA
800 972-2601 • Fax 866-908-9418

email: sales@cmdie.com

Dremel Moto Tool®



28,000 R.P.M. maximum. #402 mandrel and #409 grinding disk included.

Dumore Grinder



Model # 10-351, 22,000 R.P.M. maximum. #39 Mandrel for 1/8" center hole grinding wheels.

Handee Air Grinder

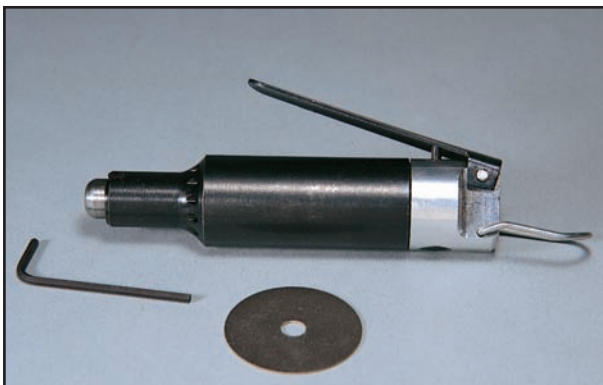

17,500 R.P.M. maximum at 90 P.S.I. #8000 - 1/8" Collet. #8500 - 1/4" Collet (1/8" available).

Nicking Chisel Set



This handy tool is an inexpensive way to nick flat or rotary dies. Comes complete with 3 tip sizes - .020", .030" & .040". Special tips are available. .010", .015", .050", .060", .070" and .080". **Tips up to .030" should only be used on medium hard rule or softer.**

Grinding Wheels

Rubber Bonded (22,000 R.P.M. max.) 1-1/2" diameter with 1/8" center hole. Available in .015", .020", .025", .031", .040", .045" and .062" thicknesses. Packaged in lots of 40 wheels. Also available in 2" dia. (18,000 R.P.M. max.).

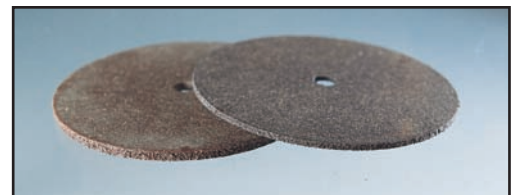

Reinforced - 2" diameter wheels with 1/8" center hole. Available in .025", .030", .035", .045", .060" and .125" thicknesses.

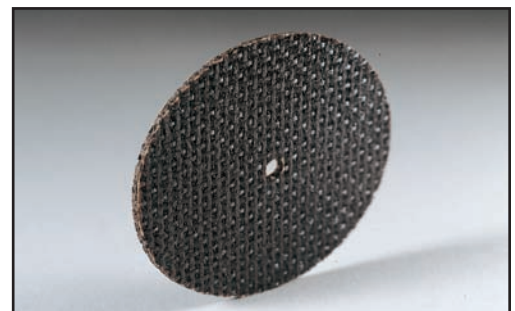

FOR PRODUCT INFORMATION AND ORDERS CONTACT:

CCM Die Supply • Martinsburg, WV
800 451-7373 • Fax 866-708-4686

CCM Die Supply • Woodbridge, CT
800 451-7373 • Fax 866-708-4686

CCM Die Supply • Tucker, GA
800 972-2601 • Fax 866-908-9418

email: sales@ccmdie.com

Air Powered Tacker



National Steel Rule

This Air Powered Tacker is used to quickly mount Aluminum Stripper as well as Aluminum Surface Score and Kushion Crease to the dieboard. Engineered to provide years of reliable service. Specially-designed Hardened Staples are available in sizes from 1/2" to 1-1/4".

Hardened Staples for Air Tacker

Sizes Available	Quantity per Box
1/2", 5/8", 3/4", 7/8", 1", 1-1/8"	5,000 Staples
1-1/4"	4,000 Staples

Aluminum Stripper

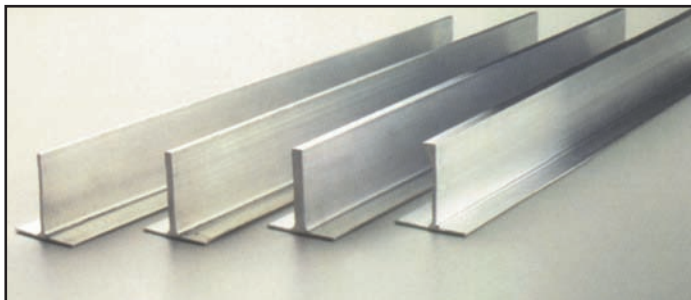

Aluminum Stripper offers a quick and economical method of building male stripping boards. This product can be used in conjunction with or in place of typical methods such as wood. This surface mounted product is available in four widths and is particularly useful where the integrity of the male board might be compromised by cutting too many kerfs. Aluminum Stripper is easily installed using the Air Tacker and Hardened Staples mentioned above. Available sizes: 1/16", 1/8", 3/16" and 1/4" in 1.375" high for use with 5/8" thick die board.

Aluminum Score

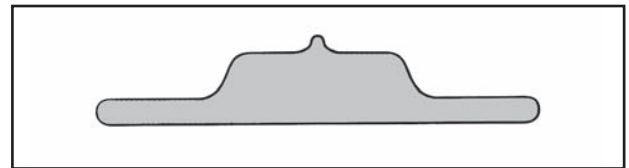

Aluminum Surface Score offers ease of application along with the ability to achieve score profiles unavailable in steel. Aluminum Surface Score is easily mounted using the Air Tacker and Hardened Staples mentioned at the top of this page.

Available in .220" (5.59mm) or .260" (6.60mm) in 3 pt. shallow profile.

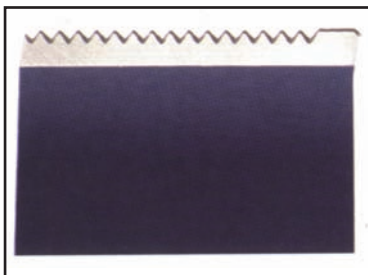

Straight Miter Tight sizes:
.937", .970", .990" and 1" to match-up to vertical knives.



Curved Miter Tight sizes:
.960", .990", 1" and 1.025" to match-up to horizontal knives. Curved blades have no back notch to assure that the stop rule will butt up to a solid piece of steel.

Miter Tight (Pre-Cut Miter Rule)

Scrap buildup is a common cause of lead edge knife failure. Miter Tight blades are designed to prevent scrap build-up by precisely matching the contour of the bevel rules commonly used in lead edges. Miter Tight blades are pre-cut in standard 1-1/2" lengths that save time in ruling and simplify programming.

FOR PRODUCT INFORMATION AND ORDERS CONTACT:

CCM Die Supply • Martinsburg, WV
800 451-7373 • Fax 866-708-4686

CCM Die Supply • Woodbridge, CT
800 451-7373 • Fax 866-708-4686

CCM Die Supply • Tucker, GA
800 972-2601 • Fax 866-908-9418

email: sales@ccmdie.com

Rule Guard



Easily mounts to the edges of two pieces of rotary boards, maintains consistent alignment for accurate cutting.



When storing rotary dies, the Rule Guard protects steel rule located near the edges of the die.

Shoulder Flex

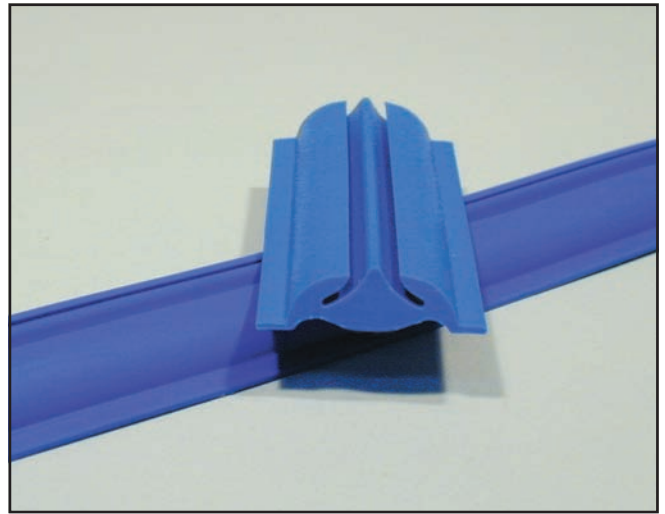

Surface mounted, easy to install helps prevent corrugated board from cracking during scoring.

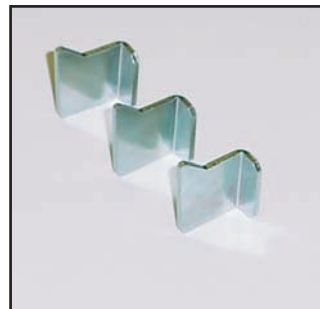

The LeGard (Lead edge guard) braces the lead knife against impact and maintains a tight fit between trim knife and the lead knife. Sold in lots of 100.

Rotary Miter Knives

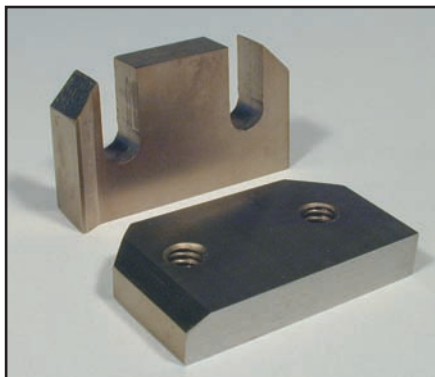

Mitering is made simple for Rotary Rule, designed to easily replace the cutting blades on your existing Helmold Rule Cutter.

4-Way Adjustable Hardware

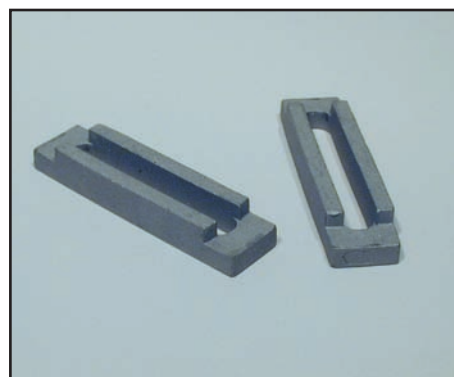

3" overall length with a 2" long adjusting slot that is 1/4" - 5/16" wide. Also available in a 4" overall length with a 3" adjusting slot.

Stretch Measuring Tape



Stretch Measuring Tape is used for laying out of rotary die boards. Compensates for differences between flat and rotary measures. Available for 1/2" and 5/8" wood for a 66" cylinder, .970 high rule.

FOR PRODUCT INFORMATION AND ORDERS CONTACT:

CCM Die Supply • Martinsburg, WV
800 451-7373 • Fax 866-708-4686

CCM Die Supply • Woodbridge, CT
800 451-7373 • Fax 866-708-4686

CCM Die Supply • Tucker, GA
800 972-2601 • Fax 866-908-9418

email: sales@cmdie.com

A World of Steel Rule...

CCM Die Supply represents the world leaders in Steel Rule products. Each manufacturer represented specializes in different types of steel rule for specific cutting applications. Each manufacturer will be featured with their own section in this catalog.

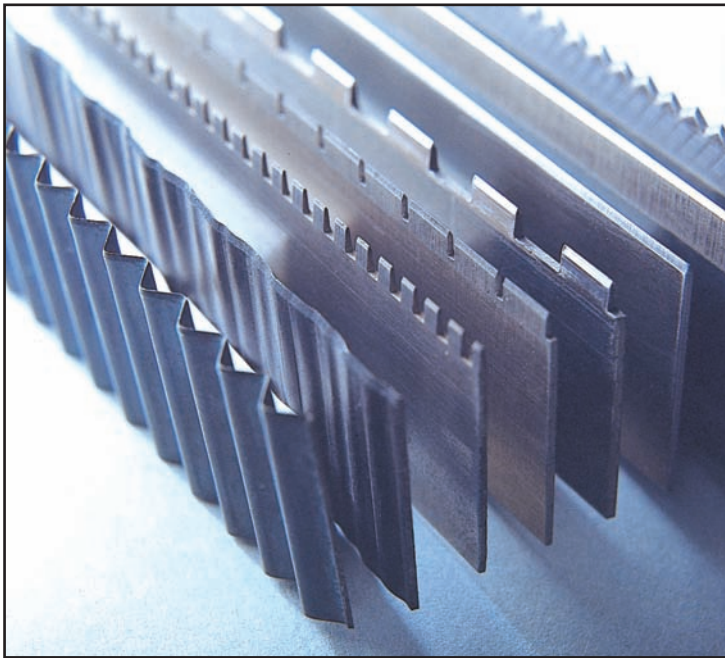

General Steel Rule Specifications:

Steel Rule Thicknesses

1 pt.	–	.014	(0.36 mm)
1-1/2 pt.	–	.021	(0.53 mm)
2 pt.	–	.028	(0.71mm)
3 pt.	–	.042	(1.07 mm)
4 pt.	–	.056	(1.42 mm)
6 pt.	–	.084	(2.13 mm)
8 pt.	–	.112	(2.84 mm)

Steel Rule - Lengths & Conversions

30" Length Strips		1 meter Length Strips	
Total Feet	Strips Needed	Total Feet	Strips Needed
250'	100	328'	100
175'	70	248'	75
165'	66	164'	50
82-1/2'	33	82'	25
75'	30	66'	20
50'	20	49'	15
25'	10	33'	10

1 meter = 3.28' or 39.4" 30 meters = 98.5'

FOR PRODUCT INFORMATION AND ORDERS CONTACT:

CCM Die Supply • Martinsburg, WV
800 451-7373 • Fax 866-708-4686

CCM Die Supply • Woodbridge, CT
800 451-7373 • Fax 866-708-4686

CCM Die Supply • Tucker, GA
800 972-2601 • Fax 866-908-9418

email: sales@ccmdie.com

General Steel Rule Specifications

Cutting Rule Bevel Profiles

Center Bevel

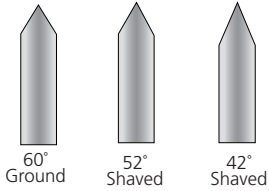

Known As:

Center Bevel, Standard Bevel Double Bevel, Center Face or A Bevel.

Typical uses:

This is by far the most popular bevel for conventional paperboard cutting. Approximately 85% of all paperboard cutting is done with a Center Bevel rule.

Note: Other ground and shaved angles available upon request. Angles vary among rule manufacturers.

Single Bevel

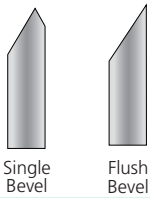

Side Bevel, Single Bevel, Side Face, B Bevel or Flush Bevel

Single Bevel rule produces a square finish. It's also used to produce tighter bends, compared to Center Bevel rule.

Long Center Bevel



Standard length of Bevel:
2 pt. - 1/8" long
3 pt. - 3/16" long
4 pt. - 1/8" or 3/16" long

Long Center Bevel, Double Double Bevel, Center Face Double Bevel, Facet Bevel or AA Bevel

This rule is especially effective when cutting hard and/or thick materials. It helps reduce cutting pressure by deflecting pressure with the first bevel supported by the second bevel.

Long Single Bevel



Bevel lengths same as Long Center Bevel (above).

Long Side Bevel, Long Single Bevel, Side Face Double Bevel, Side Facet Bevel or BB Bevel.

Also used for cutting thicker and/or harder materials. The long Single Bevel design reduces the crush to the finish die cut product when the bevel faces away from the piece.

Creasing Rule Profiles

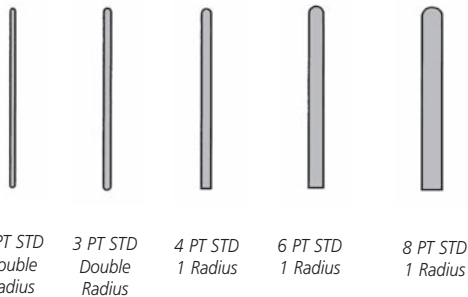

Known As:

Crease Rule or Score Rule
(Not to be confused with Cut Score Rule which is a lower height cutting rule to cut only part way through the surface of the board.)

Typical uses:

Designed to make the impression in the die cut product where folding will take place.

Diagrams courtesy of National Steel Rule.

FOR PRODUCT INFORMATION AND ORDERS CONTACT:

CCM Die Supply • Martinsburg, WV
800 451-7373 • Fax 866-708-4686

CCM Die Supply • Woodbridge, CT
800 451-7373 • Fax 866-708-4686

CCM Die Supply • Tucker, GA
800 972-2601 • Fax 866-908-9418

email: sales@cmdie.com

General Steel Rule Specifications

Laser Crease Rule Profiles

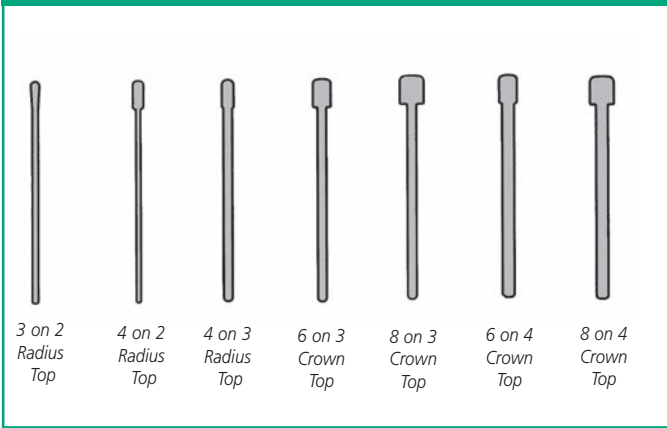

National Tru-Fold

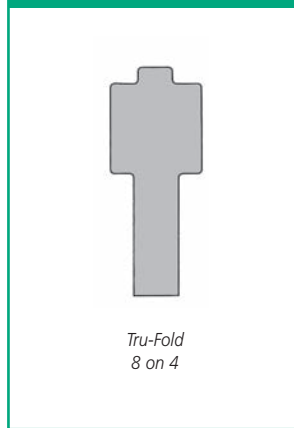

Narrow Profile

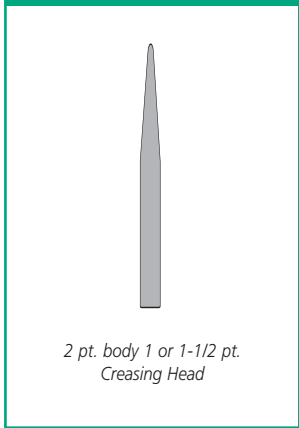

Perforating Rule Descriptions

—————	2 teeth per inch	- - - - -	1/16" tooth x 1/8" space
—————	3 teeth per inch	- - - - -	3/32" tooth x 1/32" space
—————	4 teeth per inch	- - - - -	3/32" tooth x 1/16" space
—————	6 teeth per inch	- - - - -	3/32" tooth x 3/32" space
- - - - -	8-1/4 teeth per inch	- - - - -	1/8" tooth x 1/32" space
- - - - -	12 teeth per inch	- - - - -	1/8" tooth x 1/16" space
.....	17 teeth per inch	- - - - -	1/8" tooth x 3/32" space
- - - - -	1/16" tooth x 1/16" space	- - - - -	5/32" tooth x 3/32" space
- - - - -	1/8" tooth x 1/8" space	- - - - -	3/16" tooth x 1/16" space
.....	1/32" tooth x 1/32" space	—————	1/4" tooth x 1/32" space
- - - - -	12 teeth – .039 space	—————	1/4" tooth x 1/4" space
- - - - -	1/16" tooth x 1/32" space	—————	1/2" tooth x 1/32" space
- - - - -	1/16" tooth x 3/32" space		

Profiles are actual size.

Combination Cut-Crease Rule



Recommended combinations - any combination of these Cut & Crease dimensions are available.

Cut, inch.	1/4"	5/16"	3/8"	7/16"	1/2"	9/16"	5/8"	11/16"	3/4"	1"
Crease, inch.	1/4"	5/16"	3/8"	7/16"	1/2"	9/16"	5/8"	11/16"	3/4"	1"

Glue Flap Rule

2 pt. 1/32" th x 1/32" sp Perforating Rule with a medium wave. Designed in creasing height to enhance glue performance by providing a porous surface on the flap



FOR PRODUCT INFORMATION AND ORDERS CONTACT:

CCM Die Supply • Martinsburg, WV
800 451-7373 • Fax 866-708-4686

CCM Die Supply • Woodbridge, CT
800 451-7373 • Fax 866-708-4686

CCM Die Supply • Tucker, GA
800 972-2601 • Fax 866-908-9418

email: sales@cmdie.com

General Steel Rule Specifications

Wagner Edge Wave Rule



Simonds/Notting Edge Wave Rule

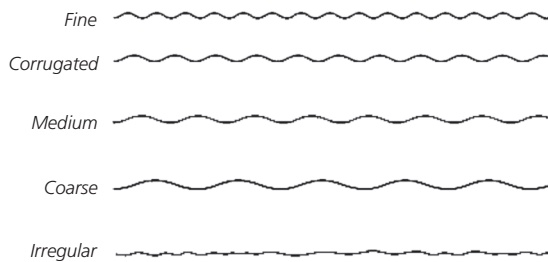

National - Edge Wave Rule

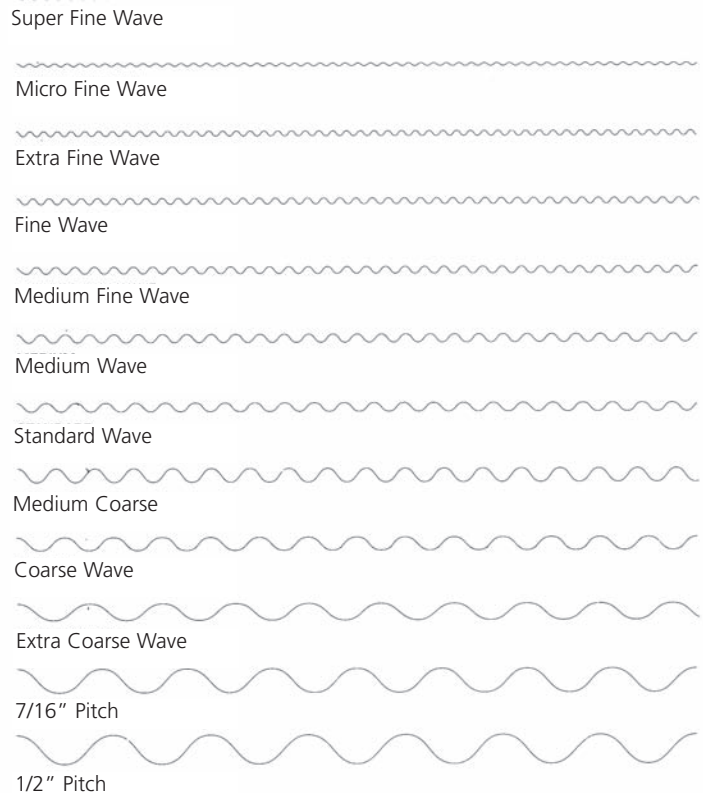

Available in 2 pt., 3 pt. and 4 pt. thicknesses in .375" (9.53 mm) to 2" (50.8 mm) heights.

Helmold Full Body Wave Rule

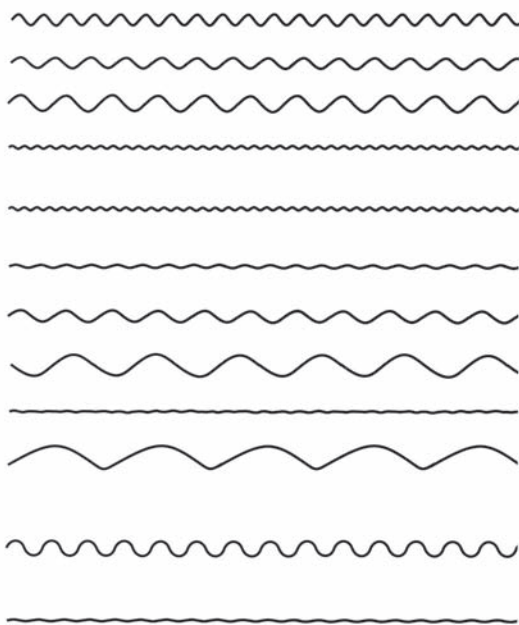

Thickness	Description	Length	Height
1-1/2 pt.	Fine Angle	27-3/8"	.945" Max
1-1/2 pt.	Medium Angle	26-5/8"	.945" Max.
1-1/2 pt.	Coarse	24-3/4"	.945" Max.
2 pt.	Extra Fine Angle (Hard Temper)	7-1/2"	.945" Max.
2 pt.	Extra Fine Angle (Soft Temper)	30"	.945" Max.
2 pt.	Fine Angle	29"	1-1/4" Max.
2 pt.	Medium Angle	28-5/8"	1-1/8" Max.
2 pt.	Coarse Angle	26-3/4"	1-1/2" Max.
2 pt.	Deckle Edge	30-5/8"	.945" Max.
2 pt.	Scalloped Wave (Specify center to center distance scallop depth.)	28-3/4"	.937" Max.
1-1/2 pt.	Close Wave (Avail. with 1/64" or 1/32" slot.)	23-1/2"	.945" Max.
2 pt., 3 pt.	Corrugated Edge (Fat Body)	30"	1-1/2" Max.

Patterns are not actual size.

FOR PRODUCT INFORMATION AND ORDERS CONTACT:

CCM Die Supply • Martinsburg, WV
800 451-7373 • Fax 866-708-4686

CCM Die Supply • Woodbridge, CT
800 451-7373 • Fax 866-708-4686

CCM Die Supply • Tucker, GA
800 972-2601 • Fax 866-908-9418

email: sales@ccmdie.com

General Steel Rule Specifications

National Tear Edge Rule

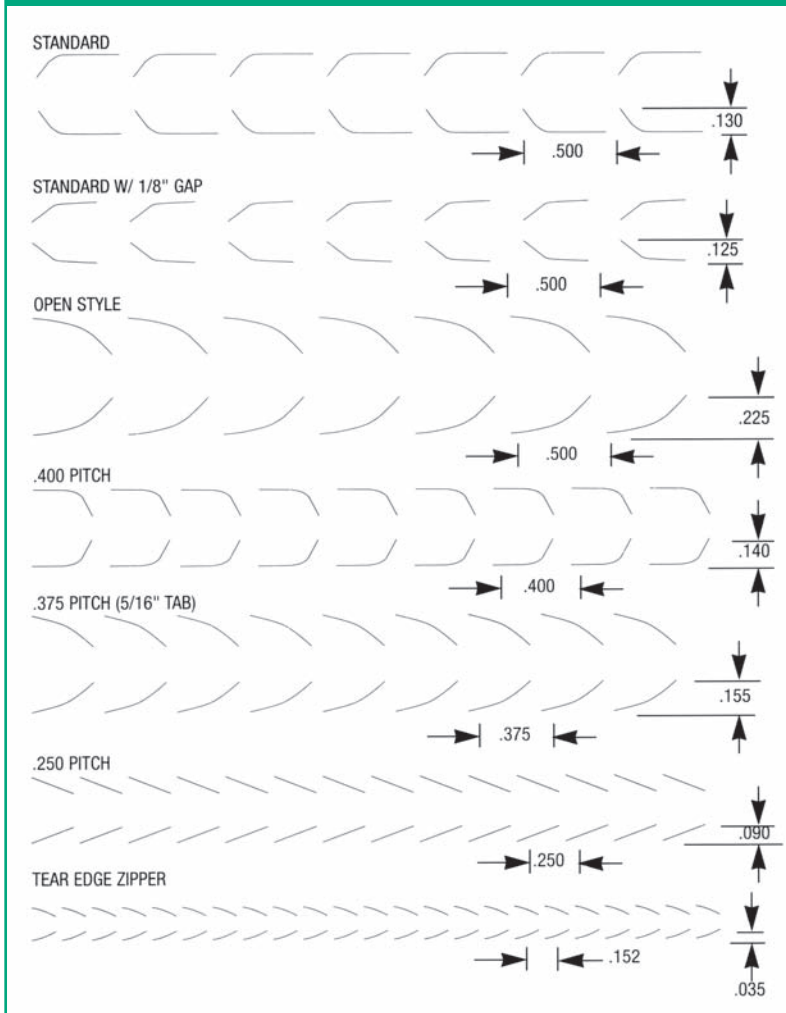

Helmold Tear Edge or Zipper

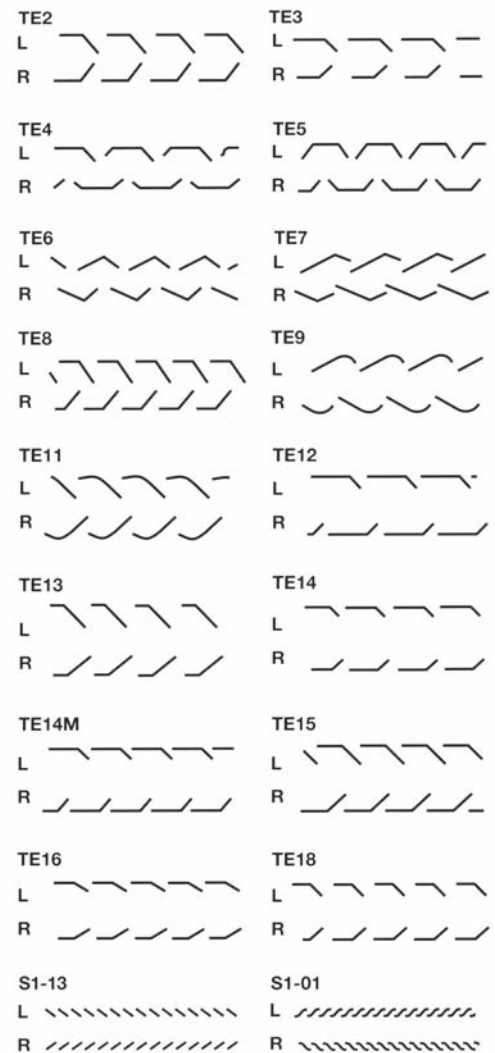

Profiles are smaller than actual size.

Simonds/Notting Zipper & Tear Edge Rule

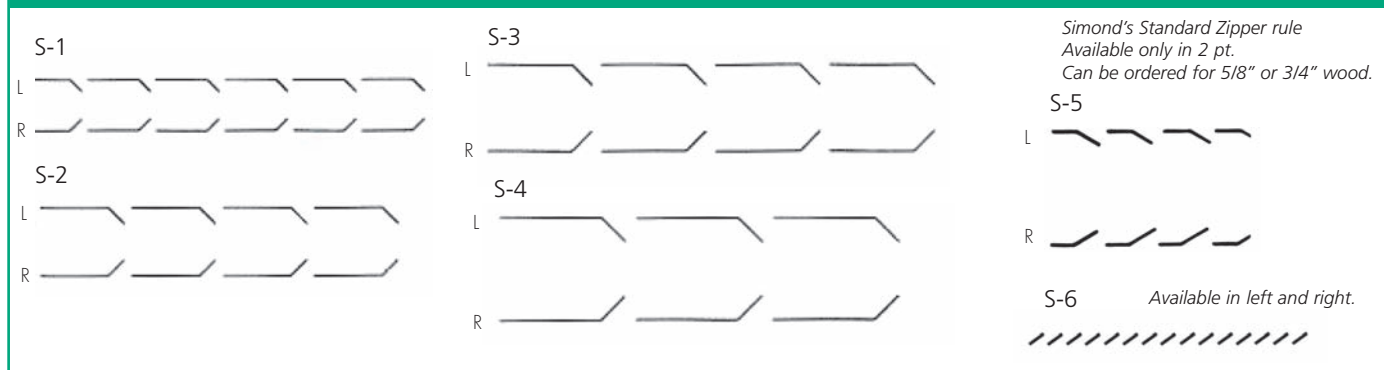

FOR PRODUCT INFORMATION AND ORDERS CONTACT:

CCM Die Supply • Martinsburg, WV
 800 451-7373 • Fax 866-708-4686

CCM Die Supply • Woodbridge, CT
 800 451-7373 • Fax 866-708-4686

CCM Die Supply • Tucker, GA
 800 972-2601 • Fax 866-908-9418

email: sales@cmdie.com



Böhler produces a wide variety of quality steel rule products for a variety of applications. Contact your Wagner Supply Group location for available bevels, finishes, specifications and product recommendations.

Böhler Universal Cutting Rule

- Medium hard body and a soft ductile outer skin.
- A perfectly shaved bevel as standard or a precision-ground edge on request.
- Extra hard cutting edge
- Excellent bendability.
- Uniform straightness.
- Uniform height and width.

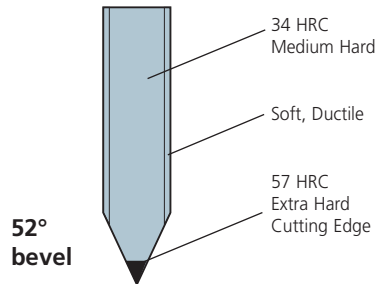

Applications:

- Cardboard
- Corrugated board
- Labels
- Post cards
- Business cards
- Jigsaw puzzles

Böhler Universal 60 Cutting Rule

- Very hard body and a soft ductile outer skin.
- A perfectly shaved bevel as standard or a precision-ground edge on request.
- Extra hard cutting edge
- Good bendability.
- Uniform straightness.
- Uniform height and width.

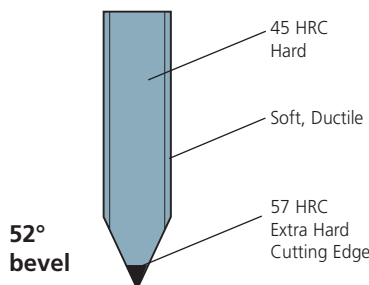

Applications:

- Plastics
- Synthetics
- Thin Gaskets
- Foils
- Jigsaw puzzles

FOR PRODUCT INFORMATION AND ORDERS CONTACT:

CCM Die Supply • Martinsburg, WV
800 451-7373 • Fax 866-708-4686

CCM Die Supply • Woodbridge, CT
800 451-7373 • Fax 866-708-4686

CCM Die Supply • Tucker, GA
800 972-2601 • Fax 866-908-9418

email: sales@ccmdie.com

Böhler Universal 75 Cutting Rule

- Very hard body and a soft ductile outer skin.
- A perfectly shaved bevel as standard or a precision-ground edge on request.
- Extra hard cutting edge
- Reliable 90° bendability
- Uniform straightness.
- Uniform height and width.

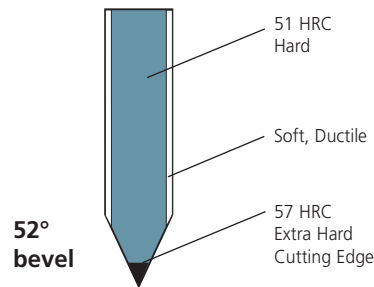

Applications:

- Non-asbestos gaskets
- Glass fiber laminates
- Carbon fiber plates
- Metal foils
- Floor coverings
- Plastics and synthetics

Böhler Universal Super Cutting Rule (K-back)

- Medium hard body and a soft ductile outer skin.
- A slimmer cutting bevel, 45°
- Extra hard cutting edge
- Excellent bendability
- Uniform straightness.
- Uniform height and width.
- Exclusive "K-back" (Radius Back)

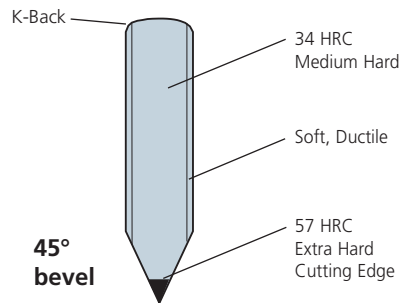

Applications:

- Cardboard
- Corrugated board
- Recycled stocks

Böhler Top Cutting Rule

- Uniform hard body and a soft ductile outer skin.
- A perfectly shaved bevel.
- Good bendability
- Uniform straightness.
- Uniform height and width.
- Also used for Böhler special rules.

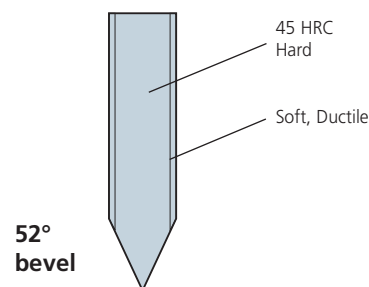

Applications:

- Cardboard
- Corrugated board
- Labels
- Post cards
- Business cards

FOR PRODUCT INFORMATION AND ORDERS CONTACT:

CCM Die Supply • Martinsburg, WV
800 451-7373 • Fax 866-708-4686

CCM Die Supply • Woodbridge, CT
800 451-7373 • Fax 866-708-4686

CCM Die Supply • Tucker, GA
800 972-2601 • Fax 866-908-9418

email: sales@cmdie.com

Böhler H 75 Cutting Rule

- Very hard body and a soft ductile outer skin.
- A perfectly shaved bevel.
- Extra hard cutting edge
- Highest stability and 90° bendability.
- Uniform straightness.
- Uniform height and width.

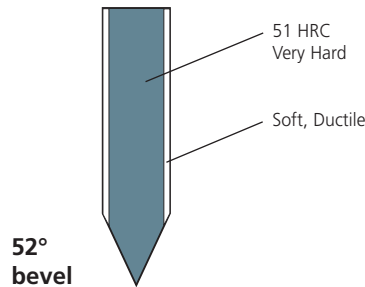

Applications:

- Gaskets
- Rubber
- Plywood
- Cork
- Felt
- Beer mats

Böhler Supreme Cutting Rule

- Special edge coating for smoothness and dust-reduced cutting.
- Particularly suited for recycled cardboard.
- Reduction in cutting force required.
- Reduction in friction between the cutting edge and the material being cut.
- Substantially increases the service life of dies.

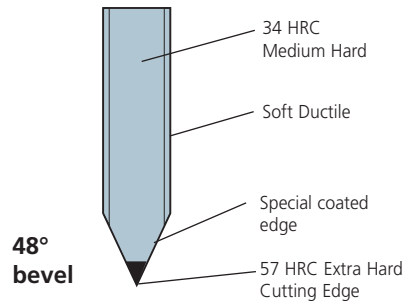

Applications:

- Excellent for long run applications like solid carton packaging in the food and pharmaceutical and tobacco industries.

Böhler Creasing Rules

- Very smooth crease head surface.
- A perfectly radiused, smooth profile.
- A flowing continuity from the radiused profile of the side faces of the rule.
- Minimum eccentricity.
- Rule thickness complimentary to cutting rules.
- Supreme - coating available.

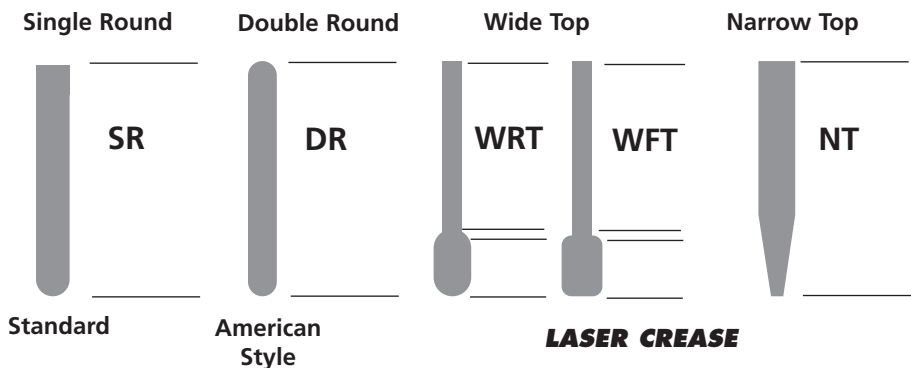

FOR PRODUCT INFORMATION AND ORDERS CONTACT:

CCM Die Supply • Martinsburg, WV
800 451-7373 • Fax 866-708-4686

CCM Die Supply • Woodbridge, CT
800 451-7373 • Fax 866-708-4686

CCM Die Supply • Tucker, GA
800 972-2601 • Fax 866-908-9418

email: sales@ccmdie.com

3

Steel Rule

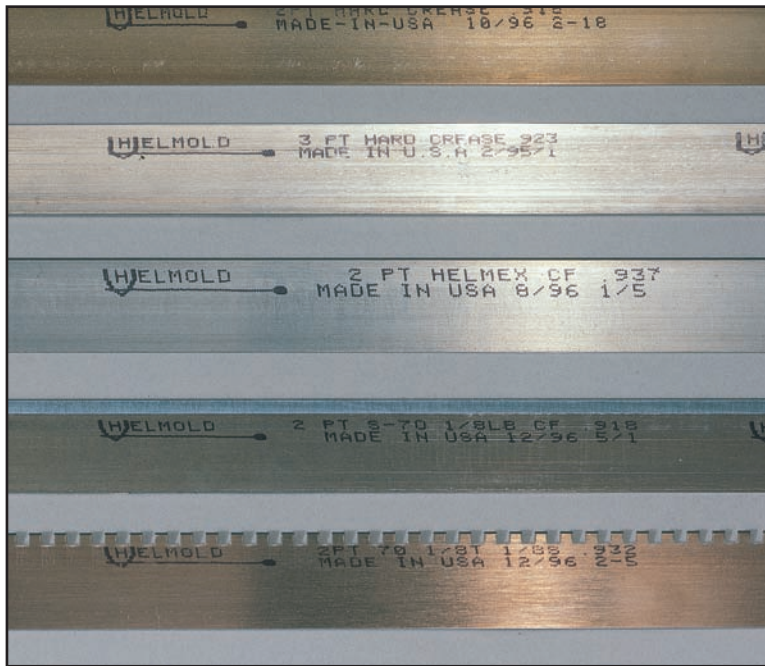

Helmold offers a wide variety of high-quality, cutting, creasing and perforating rule for a variety of uses for both flat die and rotary applications. Lazer Blade™ is Helmold's newest product, featuring highly accurate laser edge hardening.

Standard Cutting Rules

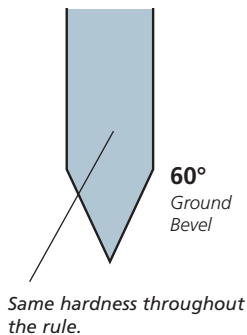

Helmold Full Hard Cutting Rule		
Scleroscopic Hardness/Description	Bend Test for 2 pt. C.B. Rule	Rockwell Hardness
#85 Extra, Extra Hard	Straight work only	HRC 57-58
#80 Extra Hard	No. 23 Die Bend	HRC 54-55
#75 Hard	No. 22 Die Bend	HRC 52-54
#70 Hard	No. 21 Die Bend	HRC 47-50
#S-70 Medium Hard	No. 21 Die Bend	HRC 43-46
#65 Medium Hard	No. 21 Die Bend	HRC 43-46
#55-60 Medium	#2 Male, #24 Female	HRC 38-41

Softer Standard Cutting Rule available upon request.

Helmex Cutting Rule

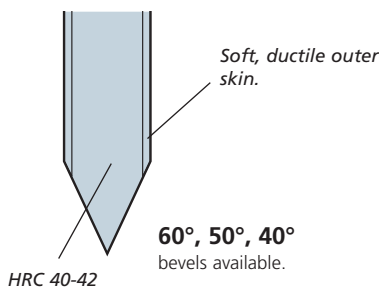

- Available in 1 pt., 1-1/2 pt., 2 pt. and 3 pt. thicknesses.
- Temper hardness: HRC 40-42
- Available in a variety of bevels in either shaved or ground edge.
- Available heights .892" to 2.000" depending on pt.
- Available in strips or coils.
- Durable cutting edge, with exceptional bending qualities.
- Formulated steel alloyed with chrome, molybdenum and nickel.
- Helmex will accept up to an #X3 die bend (2 pt.)

FOR PRODUCT INFORMATION AND ORDERS CONTACT:

CCM Die Supply • Martinsburg, WV
800 451-7373 • Fax 866-708-4686

CCM Die Supply • Woodbridge, CT
800 451-7373 • Fax 866-708-4686

CCM Die Supply • Tucker, GA
800 972-2601 • Fax 866-908-9418

email: sales@cmdie.com

Ultra Flex Cutting Rule

- Available in 2 pt., 3 pt. and 4 pt. thicknesses.
- Available in a variety of bevels in either shaved or ground edge.
- Available heights .918" to 1.125" depending on pt.
- Available in strips or coils.
- Formulated to take a tighter bend than typical #65 temper rule.
- Ultra Flex will accept up to a #2 die bend (2 pt.)
- In a ground edge, Ultra Flex is suited for cutting coated materials, plastics and adhesive-backed materials.
- In a shaved edge, for paperboard and other fibrous materials.

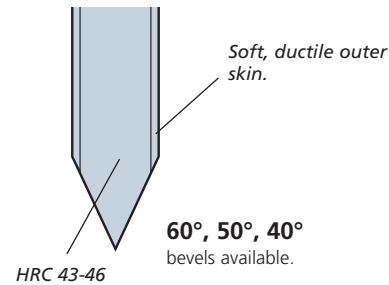

Lazer Blade™ Cutting Rule

- Available in 2 pt. and 3 pt. thicknesses.
- Standard heights available.
- Available in strips or coils.
- Using a #1 bend will take a 0.010" radius, 60° angle (2 pt. rule).
- Using an X-3 bend, will take a 0.0156" radius, 20° angle (2 pt. rule).
- Standard shaved edge, also available in ground edge.
- Laser beam hardening provides a hardened edge with no distortion to the rule body.

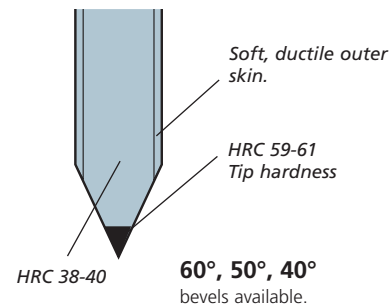

Creasing Rule

- Available in 1-1/2, 2, 3, 4, and 6 pt. thicknesses.
- Double round or single round style.
- Medium hard or soft hardnesses.

Perforating Rule

- Manufactured using high carbon steel.
- Available in a wide variety of teeth and space combinations, and controlled heights, depths and tempers.
- Available in strips or coils.

Combination Cut and Crease Rule

- Cost-effective solution where an alternating cut and crease is desired.
- Available in 1-1/2 pt., 2 pt., 3 pt. and 4 pt. thickness.
- Creasing depths of 0.0005" to 0.490".

Wave Rule

- Manufactured from the same high quality steel as other Helmold rule products.
- Wide variety of applications, from cutting safety edges on cartons, to deckle edges on greeting cards.
- See page 26 for profile chart.

Zipper or Tear Edge Rule

- Available in 15 standard styles.
- Produces a "zipper-like" self-opening feature in products like ice cream, tissue, foil and plastic bag cartons.
- See page 27 for profile chart.

FOR PRODUCT INFORMATION AND ORDERS CONTACT:

CCM Die Supply • Martinsburg, WV
800 451-7373 • Fax 866-708-4686

CCM Die Supply • Woodbridge, CT
800 451-7373 • Fax 866-708-4686

CCM Die Supply • Tucker, GA
800 972-2601 • Fax 866-908-9418

email: sales@ccmdie.com



National Steel Rule produces a wide variety of specialized rules for flat die and rotary applications. National offers various thicknesses as well as a selection of varying tooth numbers (on rotary, serrated and scalloped rule types).

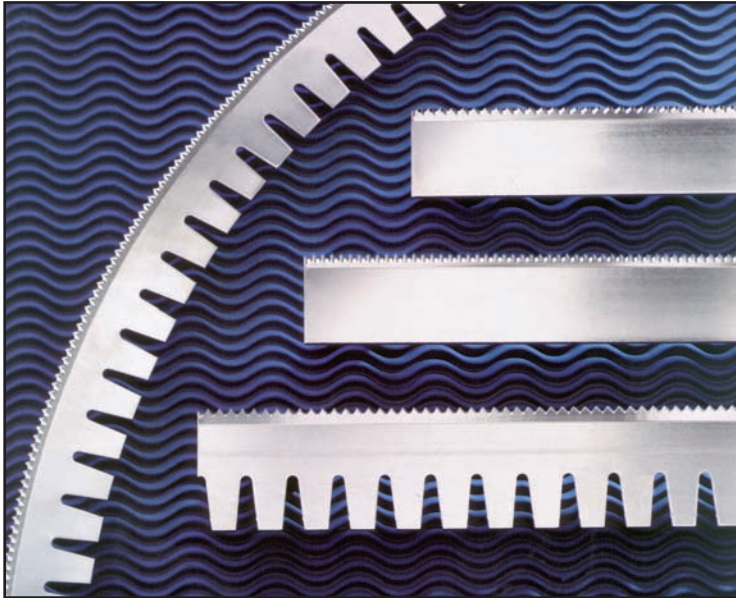

Standard 8, 10 & 12 TPI Rotary Rule

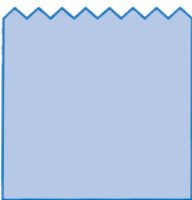

8 TPI Standard Rule



10 TPI Standard Rule



12 TPI Standard Rule

- Available in almost any height and thickness.
- Can be used on a wide variety of materials.
- Standard or Edge Hardened.
- Good bendability.
- Provides excellent anvil life.

Klean Kut 8, 10 & 13 TPI Rotary Rule

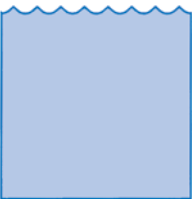

8 TPI Klean Kut Rule



10 TPI Klean Kut Rule

- Available in almost any height and thickness.
- Excellent bendability (8 TPI, 10 TPI)
- Edge Hardened at no extra cost, good bendability (13 TPI not shown)
- Reduces anvil wear
- Leaves a smooth edge on product.

Euro-Cut® Rotary Rule



8 TPI Euro-Cut® Rule
also available in 10 TPI.

- Requires less pressure.
- Improves die life.
- Reduces wear on die rubber.
- 8 & 10 TPI rule, works well on hot and wet board.
- Reduces edge crush.
- Allows for faster running speeds.

Easy Kut Rotary Rule

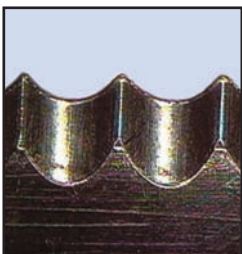

- Smooth ground cutting bevel and teeth.
- Side bevel only.
- Improved performance with reduced edge crush on heavy board.
- Recommended for use on lead and trail knives.

Arrowhead/Prism Rotary Rule

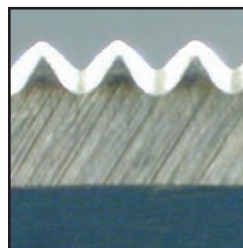

- Unique tooth geometry and bevel reduces edge crush and maximizes stripping.
- Reduces cutting pressure.
- Edge hardened, 50-54 HRC for longer life.
- Use on medium to heavy board.
- Available in 5-8 and 10 TPI, center or side bevel in strips or coils.

FOR PRODUCT INFORMATION AND ORDERS CONTACT:

CCM Die Supply • Martinsburg, WV
800 451-7373 • Fax 866-708-4686

CCM Die Supply • Woodbridge, CT
800 451-7373 • Fax 866-708-4686

CCM Die Supply • Tucker, GA
800 972-2601 • Fax 866-908-9418

email: sales@cmdie.com

Specialty Serrated Profiles

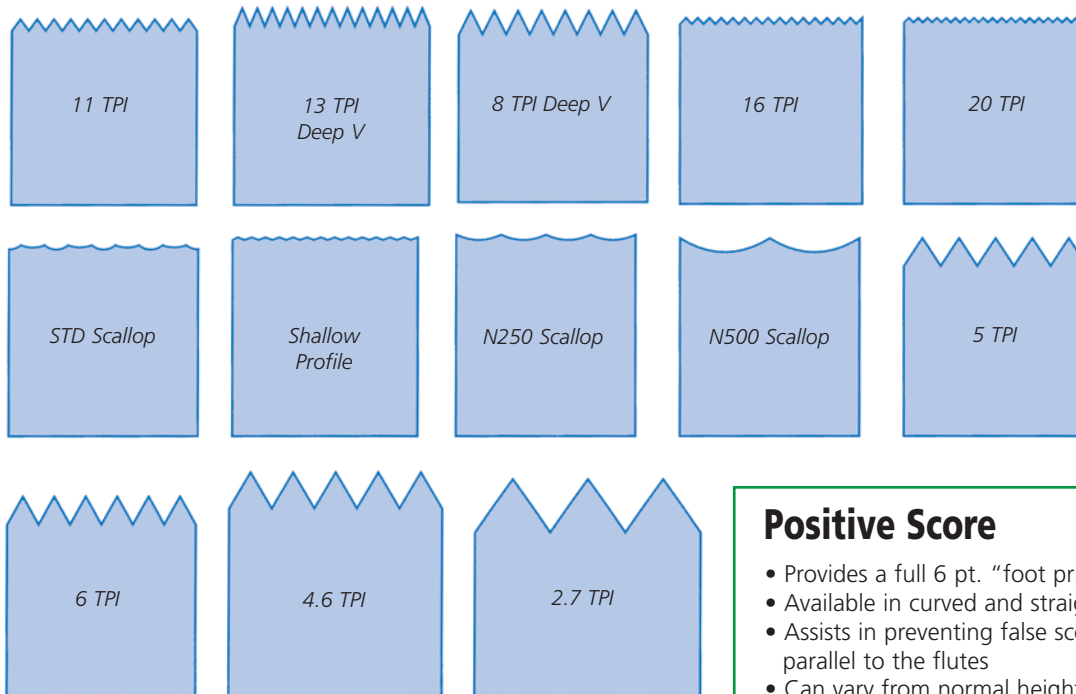

Nataloy Cutting Rule

- Available in a wide variety of heights, thicknesses and bevels.
- Excellent multi-purpose rule.
- Wears like medium hard, yet bends as well as medium.
- Available in either shaved or ground edge.
- Can be custom edge hardened.

Premium Cutting Rule

- Body hardness of 38 HRC for good bendability
- A wide variety of heights, thicknesses and bevels available.
- Precision shaved edge hardened to 54 HRC
- Thermal coated to improve lubricity.
- Excellent for corrugated and other products.

Laser Crease (See page 25 for profiles.)

- Speeds-up make ready, requires no special kerf.
- Alter score width on dies without recutting kerf.
- Made from tempered steel, will not distort when bridged.
- Available in standard as well as other edge profiles.
- Available also for rotary applications.

Positive Score

- Provides a full 6 pt. "foot print" with a 4 pt. rule.
- Available in curved and straight.
- Assists in preventing false scoring when the score is parallel to the flutes
- Can vary from normal height on creasing rule as much as 0.110" and provide a good score.
- Score to cut relationship drops to 0.110" to 0.120" using Positive Score.
- Provides a good double score when used with a firm ejection material between the scoring rules.

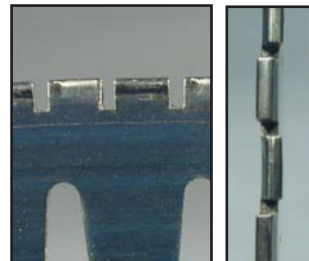

Wave Rule (See page 26 for profile chart).

- Available in a wide variety of styles (See page 26 for profile chart).
- Produced from medium hard or Nataloy steel.
- Available in many heights and thicknesses.
- All Wave Rule is available with custom edge hardening.

Tear-Edge Rule (See page 27 for profile chart).

- Adds easy opening feature, retains package integrity.
- Available in either serrated (rotary) or standard for flat dies.
- Can be customized to meet your application.
- Notched or curved versions available.

FOR PRODUCT INFORMATION AND ORDERS CONTACT:

CCM Die Supply • Martinsburg, WV
800 451-7373 • Fax 866-708-4686

CCM Die Supply • Woodbridge, CT
800 451-7373 • Fax 866-708-4686

CCM Die Supply • Tucker, GA
800 972-2601 • Fax 866-908-9418

email: sales@ccmdie.com



Sandvik offers a wide variety of rules including Dieflex, Dieflex-Ultra, Dieflex Hard, Vertex as well as a variety of creasing and specialty rules. Sandvik rules are precision manufactured to ensure long life and consistent performance in both flat and rotary diecutting operations.

Ultra™ Cutting Rule

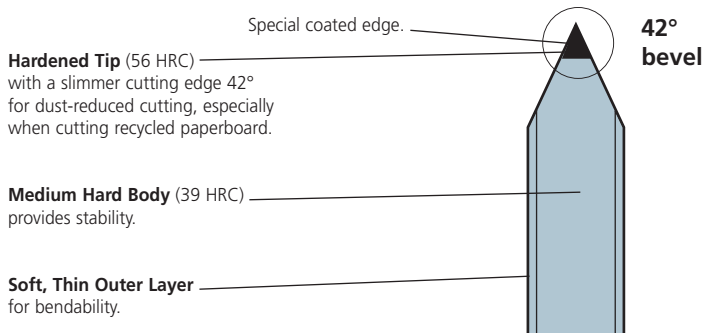

- Special edge coating for smoothness, less friction.
- Medium hard body and thin, soft outer skin.
- Hardened tip (Super hard).
- 42° edge, not the normal 52°.
- Uniform straightness.
- Uniform height and width.

Dieflex-42™ Cutting Rule

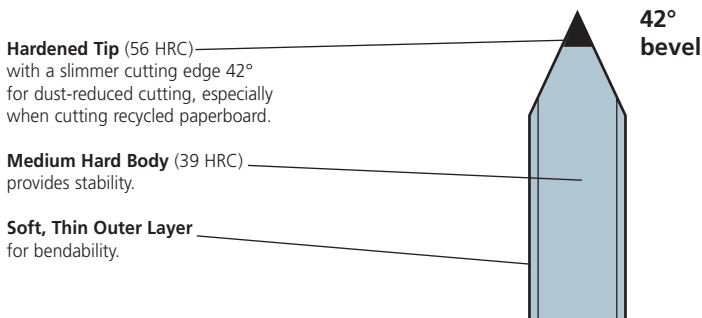

- Medium hard body and thin, soft outer skin.
- Hardened tip (Super hard).
- 42° edge, not the normal 52°.
- Uniform straightness
- Uniform height and width.

FOR PRODUCT INFORMATION AND ORDERS CONTACT:

CCM Die Supply • Martinsburg, WV
800 451-7373 • Fax 866-708-4686

CCM Die Supply • Woodbridge, CT
800 451-7373 • Fax 866-708-4686

CCM Die Supply • Tucker, GA
800 972-2601 • Fax 866-908-9418

email: sales@ccmdie.com



Dieflex Hard™ Cutting Rule

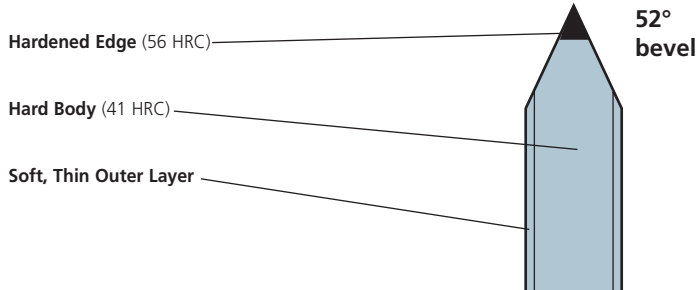

- Hard body and thin, soft outer skin.
- A shaved edge, 52° standard bevel.
- Super hard cutting edge.
- Good bendability.
- Uniform straightness
- Uniform height and width.
- Available also in 42° bevel.

Dieflex™ Cutting Rule

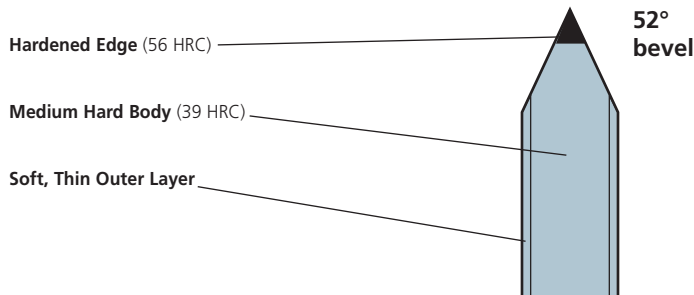

- Hard body and thin, soft outer skin.
- A shaved edge, 52° standard bevel.
- Super hard cutting edge.
- Excellent bendability.
- Uniform straightness
- Uniform height and width.
- Available also in 42° bevel.

XD-700™ Cutting Rule

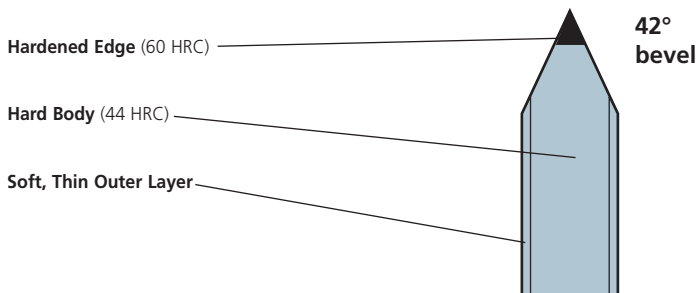

- Hard body and thin, soft outer skin.
- Super hard cutting edge.
- 42° shaved edge.
- Special edge support system.
- Excellent for gasket cutting.

Vertex™ Cutting Rule

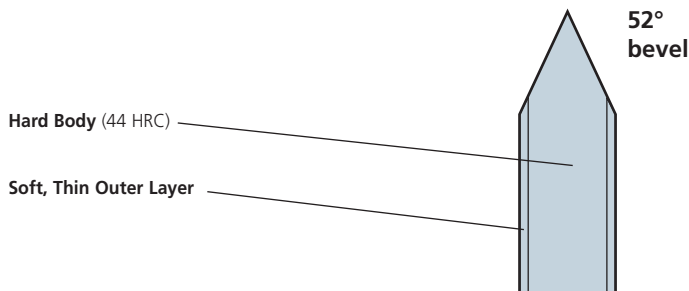

- Hard body and thin, soft outer skin.
- A shaved edge.
- Super hard cutting edge.
- Excellent formability.
- Uniform straightness.

FOR PRODUCT INFORMATION AND ORDERS CONTACT:

CCM Die Supply • Martinsburg, WV
800 451-7373 • Fax 866-708-4686

CCM Die Supply • Woodbridge, CT
800 451-7373 • Fax 866-708-4686

CCM Die Supply • Tucker, GA
800 972-2601 • Fax 866-908-9418

email: sales@ccmdie.com



"G-R" Precision Ground Cutting Rule

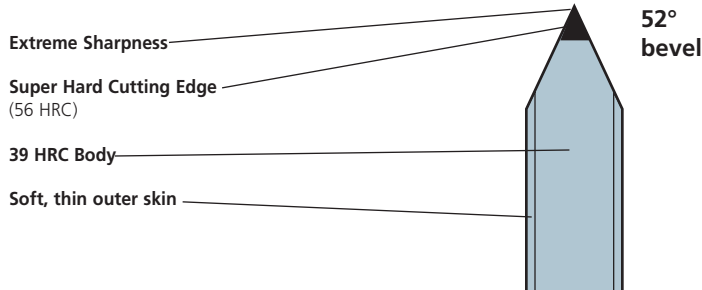

- Height accuracy $\pm .0004$.
- Superior sharpness.
- Hardened edge (56 HRC)
- Consistent, reliable bendability.
- Available also in 42° bevel.

Sandvik 400 Utility Cutting Rule

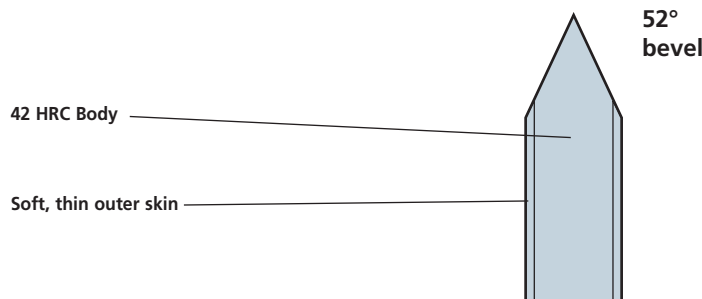

- Designed to meet the needs of the corrugated industry.
- Excellent bendability.
- Shaved edge.
- Superior dimensional accuracy.
- Economically priced.

"G-12" Precision Ground Cutting Edge Cutting Rule

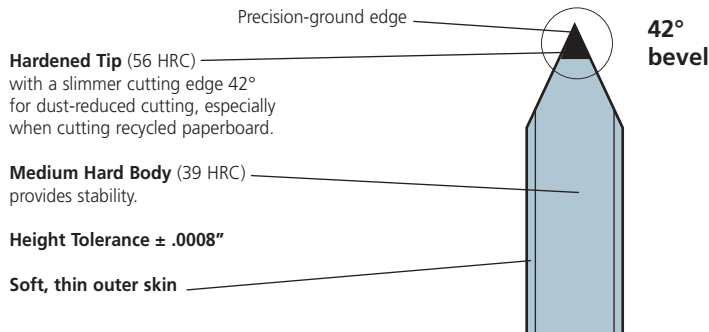

- Special edge coating for smoothness, less friction.
- Medium hard body and thin, soft outer skin.
- Hardened tip (Super hard).
- Uniform straightness
- Uniform height and width.

Creasing Rules



Reversible - Has identical, fully round shaved edges, top and bottom. Cannot be put into dies upside down. Goes into the dieboard quickly without damaging kerf. Height controlled to half standard tolerance so it will not crush the board or break the counter plate.

Uniform Straightness - Width controlled to $\pm .0005$ " to fit snugly.

Shaved Edge - Uniform creasing from the precision-shaved edges.

Made to exacting standards - Provides the straightness that the laser die industry demands: uniformly flat, with a height, width and edge that is accurate from piece to piece, box to box.

FOR PRODUCT INFORMATION AND ORDERS CONTACT:

CCM Die Supply • Martinsburg, WV
800 451-7373 • Fax 866-708-4686

CCM Die Supply • Woodbridge, CT
800 451-7373 • Fax 866-708-4686

CCM Die Supply • Tucker, GA
800 972-2601 • Fax 866-908-9418

email: sales@cmdie.com

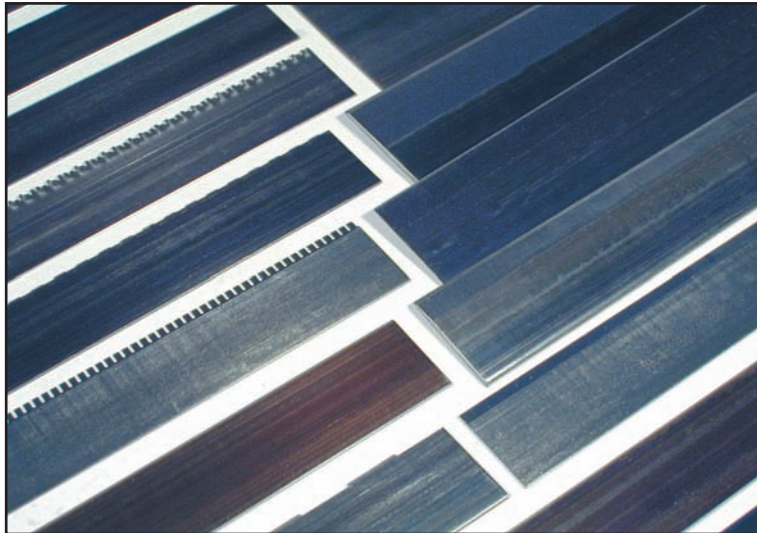

Seaboard offers a wide variety of cutting, creasing and perforating rule for flat die operations.

Seaboard Cutting Rule



- Available in .250 to 4.000" in 2, 3 and 4 pt. thickness.
- A variety of edge profiles and bevels available.
- Manufactured in strips or coils.
- Precision ground cutting edge.
- Edge hardening available.
- Available in a variety of tempers for a wide range of applications.

Perforating and Micro Perforating Rules

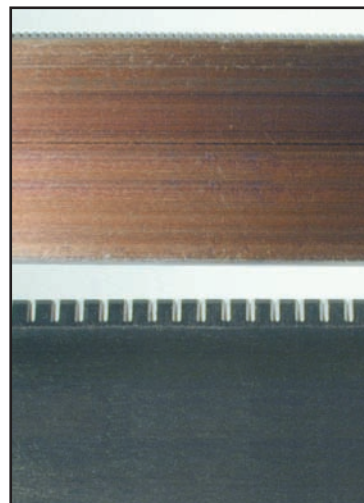

- Manufactured in Side Bevel and Center Bevel styles.
- Available in 2, 3, 4, 6 and 8 point thickness.
- Tooth configurations: 1/16" through 1.000"
- Space configurations: 1/16", 1/8", 3/16", 1/4", 5/16", 3/8", 7/16", 1/2", 5/8", 3/4", 7/8" and 1".
- Gullet depths: 2 pt. - 3/32"; 3 pt. - 1/8"; 4 pt. - 3/16"; 6 pt. - 3/16".

Combination Perf Rule

- Also called Perf-Score and Cut-Score
- Available in 2, 3, 4, 6 and 8 point thickness.
- Tooth configurations: 1/16" through 1.000"
- Space configurations: 1/16", 1/8", 3/16", 1/4", 5/16", 3/8", 7/16", 1/2", 5/8", 3/4", 7/8" and 1".

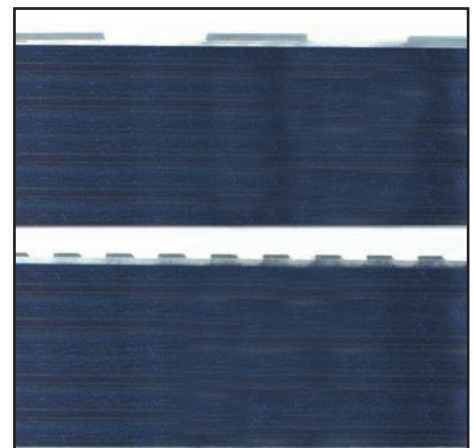

FOR PRODUCT INFORMATION AND ORDERS CONTACT:

CCM Die Supply • Martinsburg, WV
800 451-7373 • Fax 866-708-4686

CCM Die Supply • Woodbridge, CT
800 451-7373 • Fax 866-708-4686

CCM Die Supply • Tucker, GA
800 972-2601 • Fax 866-908-9418

email: sales@ccmdie.com



Viking Hard Point (HP) Cutting Rules

Martin Miller features Viking Hard Point (HP) cutting rules. Viking HP rules are manufactured using a precision controlled "Plasma Beam" hardening process, producing one of the hardest cutting edges in the industry without sacrificing bendability.

Viking Flex HP34

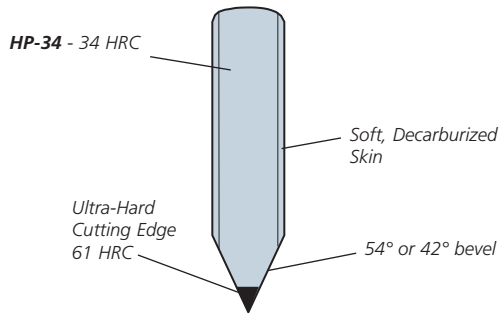

Viking Flex HP40

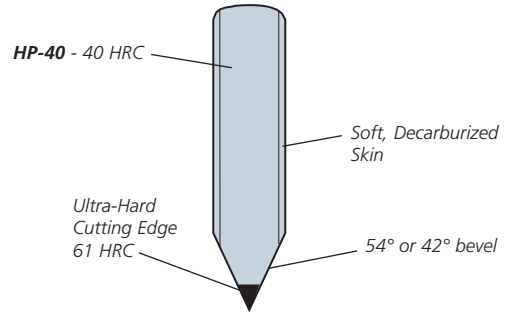

The extraordinarily high hardness of the cutting edge (61 HRC) is combined with outstanding bendability. The scaleless bright Hard Point cutting edge allows almost dust-free cutting. Both HP34 and HP40 rules are excellent for long volume press runs.

Viking Flex G-44HP

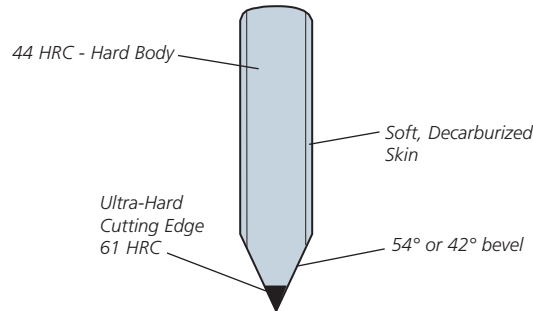

All the benefits of VIKING Flex HP coupled with a firmer body hardness. This extra stability results in a perfect cutting rule for gaskets and other hard-to-cut material. 44 HRC body, 61 HRC cutting edge.

FOR PRODUCT INFORMATION AND ORDERS CONTACT:

CCM Die Supply • Martinsburg, WV
800 451-7373 • Fax 866-708-4686

CCM Die Supply • Woodbridge, CT
800 451-7373 • Fax 866-708-4686

CCM Die Supply • Tucker, GA
800 972-2601 • Fax 866-908-9418

email: sales@ccmdie.com



Viking HF40

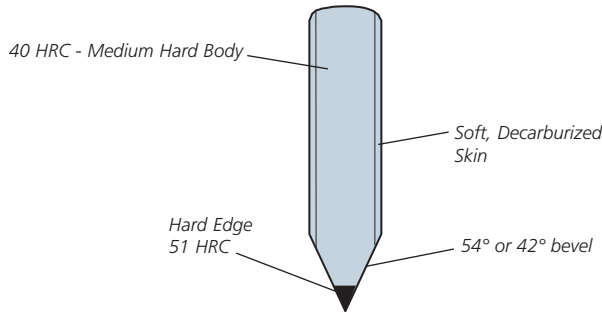

Equal to VIKING MM with an additional 51 HRC HF (high frequency) hardened cutting edge, thus combining the outstanding bendability of a 40 HRC body and a high Rockwell hardness cutting edge, for medium to long production runs. 54° or 42° bevels available.

Viking MM (44, 47)

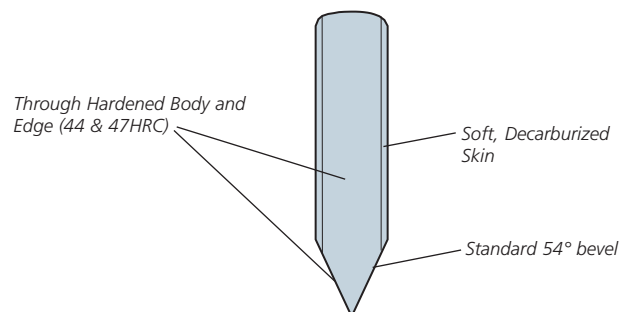

A hardened and tempered steel rule with a shaved cutting edge, uniform hardness, and decarbonized outer skin, giving outstanding bendability. 44 and 47 HRC in a 54° bevel. An excellent all-purpose rule, designed for low to medium volume press runs.

Viking Creasing Rules

Regular Crease

Single and Double Round, Hardened, Creasing Rules available in thicknesses of 2 pt., 3 pt., 4 pt. and 6 pt.

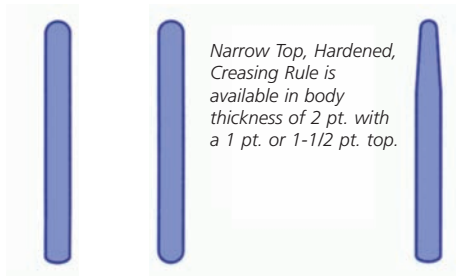

Narrow Top, Hardened, Creasing Rule is available in body thickness of 2 pt. with a 1 pt. or 1-1/2 pt. top.

Heavy Top Crease

Available in Round Top (RT) or Flat Round Top (FRT), hardened, in the following body/top thicknesses: 2/3 pt., 2/4 pt., 3/4 pt., 3/6 pt., 3/8 pt., 4/6 pt. and 4/8 pt.



Both the RT and FRT Creasing Rules allows for changes to the head of the crease, without changing the existing kerf of the dieboard.

**Martin Miller has a wide variety of rules for special applications:
Edge Wave Rule, Perforating Rule, Glue Flap Rule,
Combination Cut/Crease Rule, Stripping Rule (regular and needle),
Label (Kiss Cut) and Zipper Rules.**

FOR PRODUCT INFORMATION AND ORDERS CONTACT:

CCM Die Supply • Martinsburg, WV
800 451-7373 • Fax 866-708-4686

CCM Die Supply • Woodbridge, CT
800 451-7373 • Fax 866-708-4686

CCM Die Supply • Tucker, GA
800 972-2601 • Fax 866-908-9418

email: sales@ccmdie.com



GmbH+Co. KG

Precision-Steel-Rules

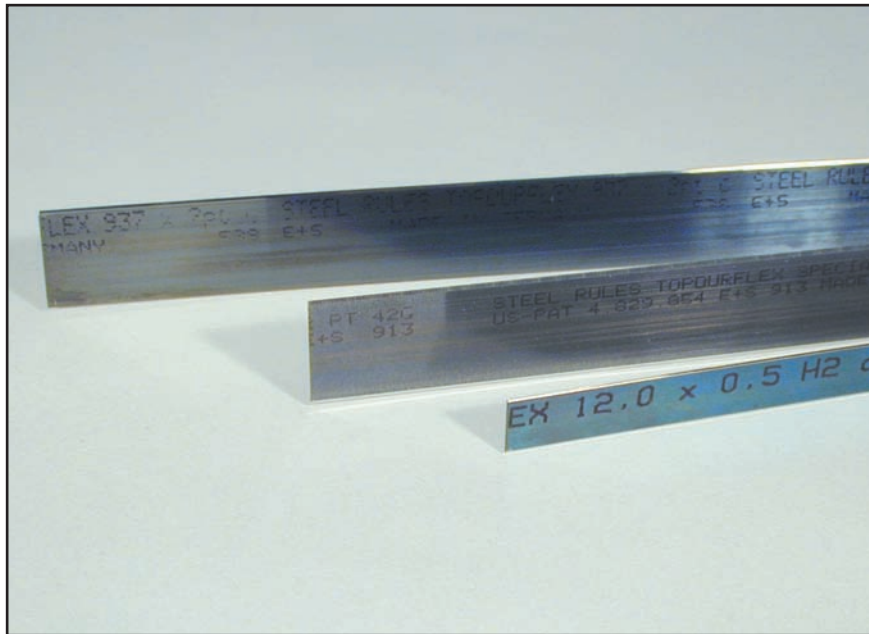

German designed and manufactured, Essman+Schaefer features TOPDURFLEX® and TOPDURFLEX Spezial 60® steel rules. These rules offer exact edge hardness and consistent bendability. Excellent for folding carton and label dies.

TopDurFlex® Cutting Rule

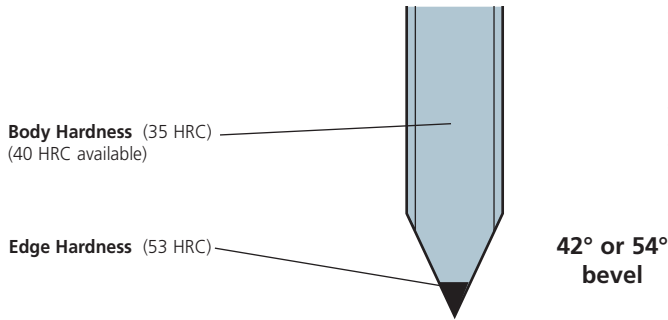

- Body hardness 35 HRC (40 HRC upon request), edge high frequency hardened to approximately 53 HRC
- Edge hardened with an exclusive technique.
- Good bendability.
- Exact edge hardness.

TopDurFlex® Spezial 60 W Cutting Rule

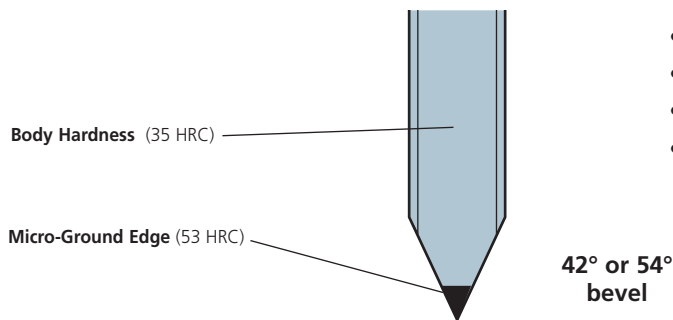

- Dust-free diecutting - micro-ground edge.
- Short makeready - ± .0004" height tolerance
- 50% reduction in cutting pressure.
- Increased die life.

FOR PRODUCT INFORMATION AND ORDERS CONTACT:

CCM Die Supply • Martinsburg, WV
800 451-7373 • Fax 866-708-4686

CCM Die Supply • Woodbridge, CT
800 451-7373 • Fax 866-708-4686

CCM Die Supply • Tucker, GA
800 972-2601 • Fax 866-908-9418

email: sales@cmdie.com

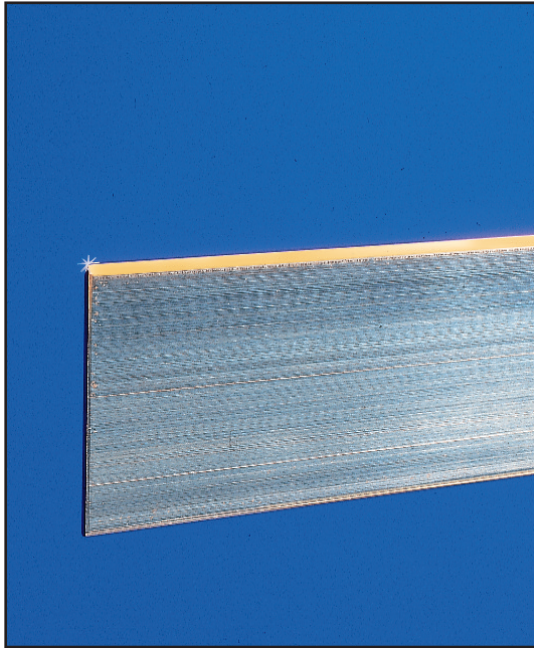

Wagner SuperCoat is pictured above.



Coated Rules

EXCLUSIVE

SuperCoatTM

SuperCoatTM cutting rule, an **exclusive of the Wagner Supply Group**, features a scientifically developed coating that strengthens the rule's cutting edge.

Bohler produces the base material incorporated in **SuperCoat**TM to strict tolerances (height tolerance ± 0.0007). When coated, the rule retains all of its bendability, and the cutting edge is tougher – **SuperCoat**TM tough!

SuperCoatTM features a 45 degree bevel; slim enough to reduce dust, yet rigid enough not to deflect when cutting. It's especially suited for cutting hard and abrasive materials.

MagnaCoat

MagnaCoat, a Wagner Supply Group exclusive, is scientifically coated to reduce dusting and increase rule life. The coating adds lubricity to the edge of the knife allowing for smooth and easy cuts without the damage associated with burrs and inclusions caused by the skiving or shaving process. Excellent for cutting coated materials with dust-free results.

TeflonCoat

Designed for cutting pressure-sensitive and other sticky materials. Wagner's Teflon coating adds lubricity to the rule, allowing the rule to release materials freely while preventing build-up, assuring smooth, delay-free press runs. Teflon coating can also be applied to Wagner punches.

Zimmer MicroNik

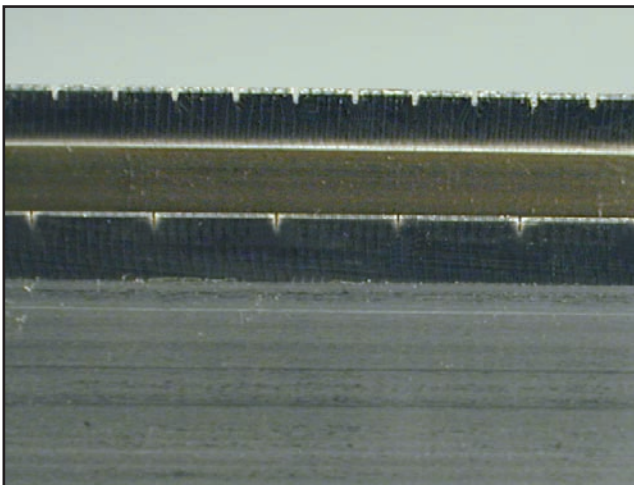

Pre-Nicked cutting rule!

Super strong nicked areas hold diecuts in sheet or board far more securely, thus allowing faster press speeds and more controlled stripping – yet at the same time, appearance and “feel” are vastly improved.

- Run your presses 20 - 30% faster with greater product control.
- Virtually invisible .007 micronicks.
- Dies are faster and easier to make.
- Dusting and flaking are minimized - even with recycled materials.
- Sleeker 42° bevel.
- Minimizes edge crush – edges look and feel smooth.

FOR PRODUCT INFORMATION AND ORDERS CONTACT:

CCM Die Supply • Martinsburg, WV
800 451-7373 • Fax 866-708-4686

CCM Die Supply • Woodbridge, CT
800 451-7373 • Fax 866-708-4686

CCM Die Supply • Tucker, GA
800 972-2601 • Fax 866-908-9418

email: sales@ccmdie.com

4

Wagner Punches

Standard Tube



FW&SON
Frank Wagner & Son

The most popular type of cutting punch made, they are used in cutting cardboard and corrugated. Standard sizes available range from 3/32" to 1-47/64" (diameter of cutting edge) in 1/64" increments, on tubing sizes from 3/16" - 1-3/4" in 1/16" increments. FW&Son standard tube punches have a tubing wall thickness of approximately 1/16". Standard tube punches are available in outside bevel, center bevel and inside bevel styles, and can be ordered with spring ejectors up to 7/8" diameter. On larger diameters ejection rubber or sponge is recommended.

STANDARD HEIGHTS: .918, .923, .937, 1", 1-1/8", 1-1/4" & 1-1/2"

DECIMAL SIZES ALSO AVAILABLE!

Punch Rubber is available in sizes to fit just about any punch. Punch Rubber is the correct height for each punch, eliminating the need for plugs. Punch sizes 9/16" and larger feature a center relief to aid in compression.



Standard Tube with Punch Rubber



Standard Tube with Spring

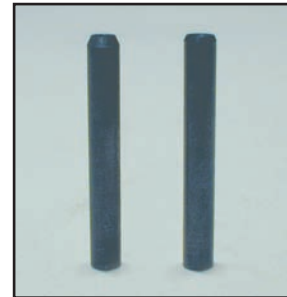

Special Base Punches

1/8" base, 7/64" cutting edge, #E00A.
1/8" base, 3/32" cutting edge, #E00B. Made from high carbon steel and precision ground.

Standard Tube Ovals



STANDARD HEIGHT: .937 (others available upon request)
BEVELS: Center, inside, slightly off-center and outside bevel.

Tube oval punches (also known as "Squeezed Oval" or "Oblong Tube" punches) are manufactured from our standard tube punches. These tube oval punches do not have fully radiused ends, if close tolerances and exact oval shape and size is required, a custom-milled punch should be ordered.

Tube Style Square Punches

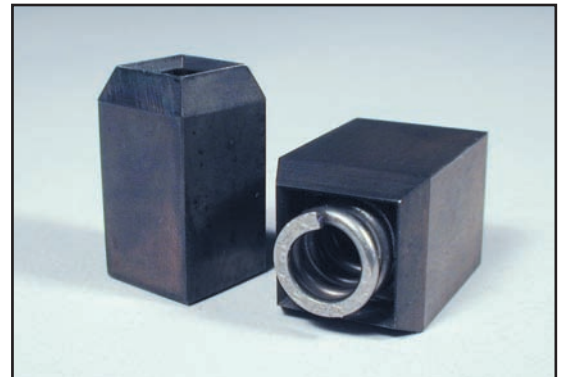

Sharp corners, can be ordered with or without springs. Range of sizes available 1/8" to 1/2" in .937 height. Other sizes and heights available upon request.

FOR PRODUCT INFORMATION AND ORDERS CONTACT:

CCM Die Supply • Martinsburg, WV
800 451-7373 • Fax 866-708-4686

CCM Die Supply • Woodbridge, CT
800 451-7373 • Fax 866-708-4686

CCM Die Supply • Tucker, GA
800 972-2601 • Fax 866-908-9418

email: sales@cmdie.com

4

Wagner Punches

007 Straight Cut Punches



007 SERIES

FW&SON
Frank Wagner & Son

007 Straight Cut Punches are made from high carbon steel and feature a minimum support bevel of .0075". The reduced wall thickness allows for the use of a larger spring. The minimum support bevel reduces cutting pressure and produces a cleaner cut. Available in cut sizes ranging from 1/8" to 1/2" in 1/64" increments. Other sizes available.

HEIGHTS AVAILABLE: .918, .937 (Other heights available upon request)

Outside / Inside Diameter Relieved Punches

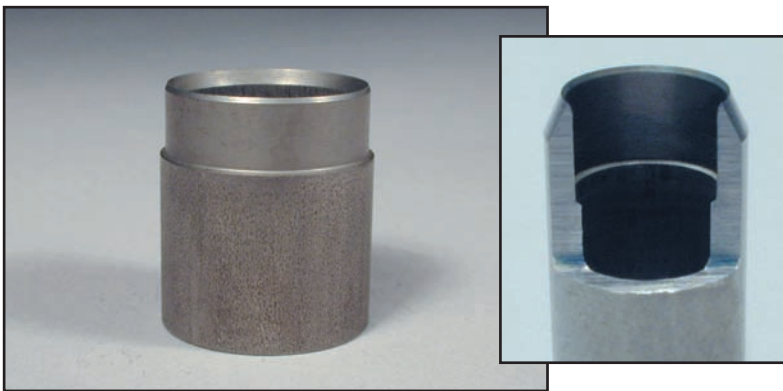

Outside relieved punches are used primarily where minimum board crush is desired. Inside relieved punches (inset, sectional view) are used as trimming dies. For example: molded parts that protrude. Both styles of relieved punches are custom-made to order.

Notched Tube



Notched punches are designed to hold the slug in the die cut board for stripping later. Available with one, two, three or more notches as required.

Straight Outside Diameter



Available in 1/64" increments from 3/32" to 1/2" dia., and 1/16" increments from 1/2" to 3/4" dia. Ground close tolerances and are designed for applications where a standard tube punch will not work.

FOR PRODUCT INFORMATION AND ORDERS CONTACT:

CCM Die Supply • Martinsburg, WV
800 451-7373 • Fax 866-708-4686

CCM Die Supply • Woodbridge, CT
800 451-7373 • Fax 866-708-4686

CCM Die Supply • Tucker, GA
800 972-2601 • Fax 866-908-9418

email: sales@cmdie.com

4

Wagner Punches



Rotary Tube Serrated



Also known as serrated punches or saw tooth punches, these punches feature a scalloped-designed bevel that allows for less cutting pressure and added blanket life. FW&Son rotary tube punches are manufactured to exact tolerances, this translates into superior cutting and improved stripping characteristics.

STANDARD HEIGHTS: .970, .990, 1", 1.023" (others available upon request)

BEVELS: Inside bevel or center bevel - outside bevel available upon request.

Cross Cuts



Cut sizes available: 1/8", 3/16", 1/4", 3/8" and 1/2" in .937 height. Other sizes and heights available upon request.

Cup Punches



This style punch cuts and forces the material into the "cup". The resulting compression ejects the slug. Made from solid rod. Available sizes from 1/16" to 31/64" in .918 and .937 heights. Other sizes and heights available upon request.

Pin Points



Used as locators, pin points are made with a sharp point as standard. They can also be ordered with a blunt end. Available in 1/8" and 3/16" base in .918 and .937 heights. Other sizes and heights available upon request.

Washer Sets



Designed to be concentric, the outside and inside punch can be furnished as a standard tube or feed-thru or a special or custom punch. Washer sets are all custom-made to order.

FOR PRODUCT INFORMATION AND ORDERS CONTACT:

CCM Die Supply • Martinsburg, WV
800 451-7373 • Fax 866-708-4686

CCM Die Supply • Woodbridge, CT
800 451-7373 • Fax 866-708-4686

CCM Die Supply • Tucker, GA
800 972-2601 • Fax 866-908-9418

[email: sales@cmdie.com](mailto:sales@cmdie.com)

Wagner Seamless Hangers

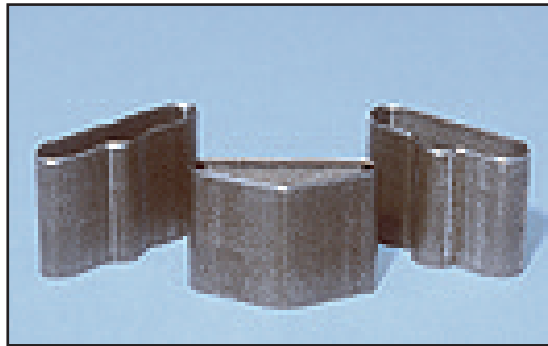

FW&SON
Frank Wagner & Son

Wagner seamless hangers can be ordered by individual part number or by exclusive Wagner "Matched Sets" set number. The cutting edge is manufactured to a tolerance of $\pm .005"$. Seamless hangers are available in heights of .918", .937", 1-1/8" and 1-1/2". Other heights are available upon request.

How FW&Son Matched Sets work:



SB10932 (small) + # SB11539 = **Set 2** (actual size)

Designed to work together precisely, Wagner Matched Sets take the guesswork out of hanger hole punching!

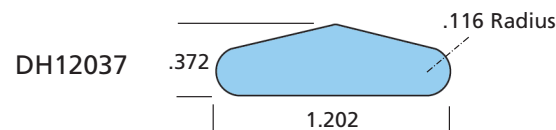
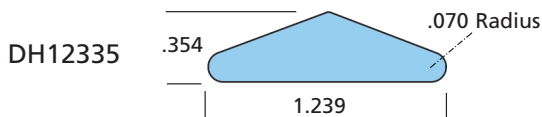
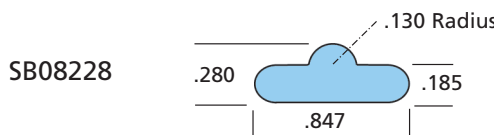
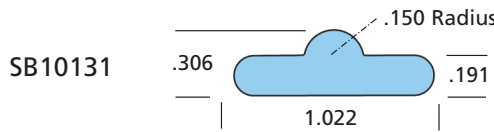
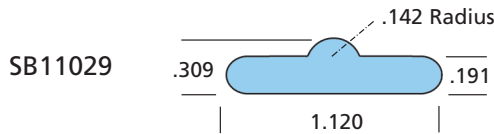
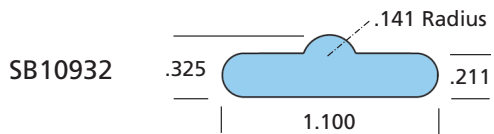
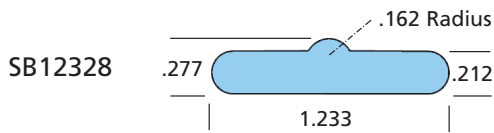

Set 2

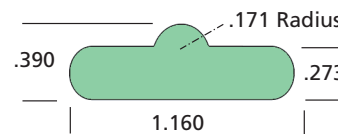

SB11539

Set 3

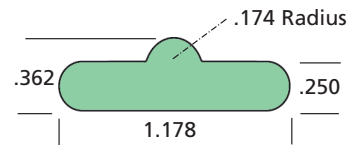

SB11737

Set 4

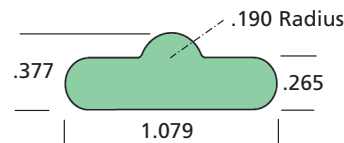

SB10737

Set 5

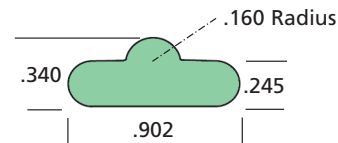

SB08934

Set 6

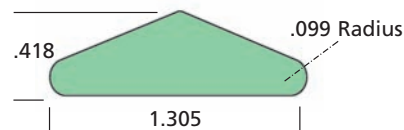

DH12942

Set 7

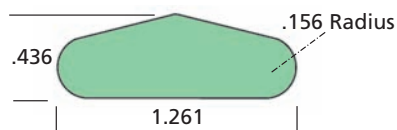

DH12543

FOR PRODUCT INFORMATION AND ORDERS CONTACT:

CCM Die Supply • Martinsburg, WV
800 451-7373 • Fax 866-708-4686

CCM Die Supply • Woodbridge, CT
800 451-7373 • Fax 866-708-4686

CCM Die Supply • Tucker, GA
800 972-2601 • Fax 866-908-9418

email: sales@ccmdie.com

Feed Thru Punches



FW&Son feed thru punches are designed to pick up the slug and feed it through smoothly. Also known as rear exhaust, flow through or top clear-out, these punches feature clean and accurate cutting edges for easier cutting. Most commonly used in gasket cutting, they are inserted in the die board with a drilled metal backing plate that secures the punch and allows the slug to pass through. Rods are placed between the metal backing plate and the press to provide clearance for the slug to eject freely from the punch. FW&Son feed thrus are available in a wide range of sizes from miniatures (1/32") through the standard sizes, to the oversize up to 1-13/32". Decimal sizes are also available.

STANDARD HEIGHT: .937 (other heights available upon request).

STANDARD FEED THRU SIZES - 3/32" TO 1-1/32" available in .937, 1-1/8", 1-1/4" and 1-1/2" Heights (other heights available upon request).

Feed Thru Ovals



Squeezed from standard feed thru punches.

Serrated Feed Thru



Scalloped design bevel allows for less cutting pressure.

Heavy Wall Feed Thru



Larger base with heavier walls for cutting thicker materials. Bored in back for clearance. Available in cut sizes from stock in 1/32" to 39/64" in .937 height.

Clicker style Feed Thru



Long bevel for cutting thicker materials like leather.

FOR PRODUCT INFORMATION AND ORDERS CONTACT:

CCM Die Supply • Martinsburg, WV
800 451-7373 • Fax 866-708-4686

CCM Die Supply • Woodbridge, CT
800 451-7373 • Fax 866-708-4686

CCM Die Supply • Tucker, GA
800 972-2601 • Fax 866-908-9418

email: sales@ccmdie.com

Self Cleaning Punches



Also referred to as side outlet, side clear or self-stripping punches FW&Son self cleaning punches are precisely manufactured for high performance. Standard sizes range from 1/32" to 1/2" dia. in 1/64" increments. Alternative base sizes are also available for tight quarters. Designed with large side exhaust holes for trouble-free stripping, FW&Son self cleaning punches are time savers when it comes to stripping. Excellent for applications where heavier stock is being cut and a standard tubing punch is unable to eject cleanly.

STANDARD STOCK HEIGHTS: .918, .937 also available in .923, 1", 1-1/8", 1-1/4" & 1-1/2", other heights available upon request.



Self Cleaning with
Knurled Base



Self Cleaning with
No-Turn Pin



Self Cleaning with
Serrated Cutting Edge

Kleen Cut™ Self Cleaning



These long bevel self cleaning punches are designed with a longer bevel to provide a truer cut on thicker materials. All Kleen Cut™ punches are manufactured with a knurled base.

AVAILABLE SIZES: .937 and 1-1/8" (others available upon request)

ALSO AVAILABLE WITHOUT A KNURLED BASE AND WITH NO-TURN PINS.

Oval Self-Cleaning

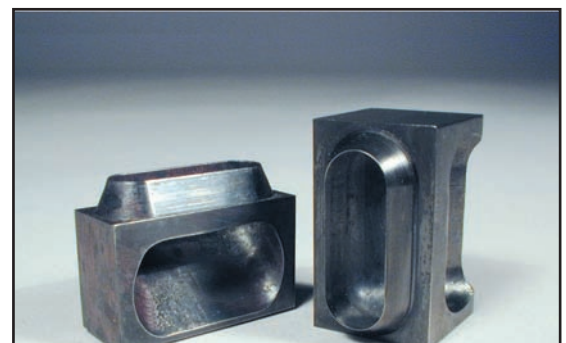

Full radius side outlet with an extra sharp cutting edge that provides a cleaner hole with less cutting pressure. A wide variety of cut sizes available from stock in .937. Other heights available upon request.

Square Self-Cleaning

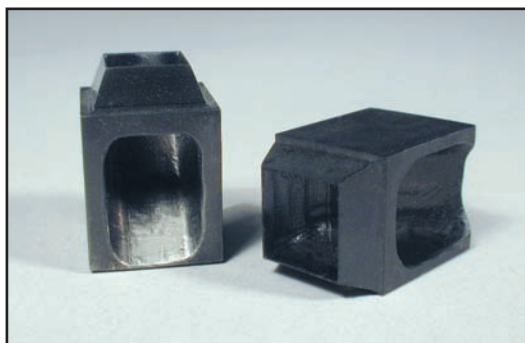

Featuring sharp corners, cut sizes range from 1/8" to 1/2" on base sizes ranging from 5/16" to 3/4". Standard height .937, other heights available upon request.

FOR PRODUCT INFORMATION AND ORDERS CONTACT:

CCM Die Supply • Martinsburg, WV
800 451-7373 • Fax 866-708-4686

CCM Die Supply • Woodbridge, CT
800 451-7373 • Fax 866-708-4686

CCM Die Supply • Tucker, GA
800 972-2601 • Fax 866-908-9418

email: sales@ccmdie.com

Rule Connectors



Standard 2 and 4 radius, center bevel, 5/16" shoulder with "V" notched ends. Spring ejector provided in 4 radius version. Available in 1/8", 3/16", 1/4", 5/16", 3/8" and 1/2" radius sizes in .937 height. Other sizes and heights available upon request.

Custom-milled Punches



Frank Wagner & Son has the engineering and CAD capabilities to produce and manufacture virtually any size, shape or style of punch as per customer specifications. All of our punches are specially heat treated using our exclusive *Enduro CBN™* process. FW&Son's unique CNC milling techniques, produce the most accurate, toughest, and sharpest cutting edge in the business.

Punches made from Steel Rule

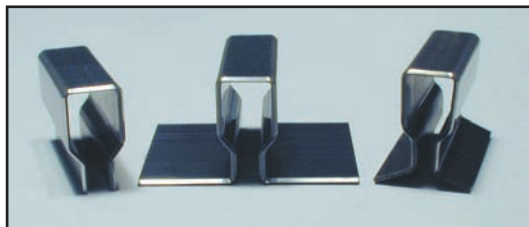

Rolodex® Punches



Steel Rule Hanger

Rolodex® style punches are available in three styles (left to right) without wings; with wings and standard style. Available in .918 and .937, 2 pt. rule.

Steel rule fabricated hanger, one size available in .918 or .937, 2 pt. rule. Cut size is 1-1/8" wide x 3/16" x 5/32" from top of "bump" to lower flat side.

FOR PRODUCT INFORMATION AND ORDERS CONTACT:

CCM Die Supply • Martinsburg, WV
800 451-7373 • Fax 866-708-4686

CCM Die Supply • Woodbridge, CT
800 451-7373 • Fax 866-708-4686

CCM Die Supply • Tucker, GA
800 972-2601 • Fax 866-908-9418

email: sales@cmdie.com

5



We carry a wide variety of ejection materials, from sponge rubbers to gum rubber strips, to stripping foam to a multitude of ejection materials. Available in sheets, strips and blocks along with special shapes as shown below. Many of our materials can be ordered with Pressure sensitive adhesive (**PSA**).

On the sample chart (next page) the numbers assigned to each product denotes the actual durometer firmness reading (i.e. "75 Red" has a durometer reading of 75).



Di-Wave strips - allows for easy and quick application, automatically spaces rubber adequately from the steel rule.

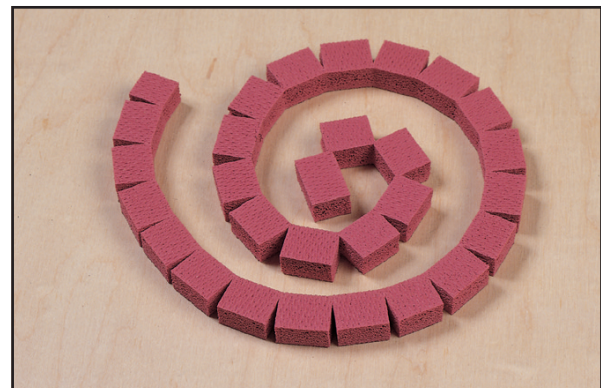

Di-Curve strips - makes rubbering dies with curved steel rule a snap!

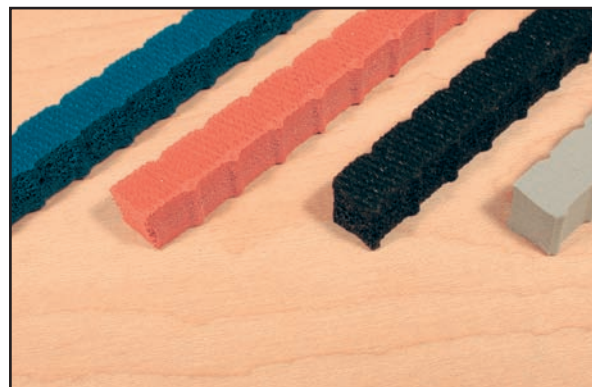

Di-Point strips - points allows for correct spacing automatically from the steel rule.



Di-Taper strips - specially designed taper automatically keeps the rubber away from the rule during compression.

FOR PRODUCT INFORMATION AND ORDERS CONTACT:

CCM Die Supply • Martinsburg, WV
800 451-7373 • Fax 866-708-4686

CCM Die Supply • Woodbridge, CT
800 451-7373 • Fax 866-708-4686

CCM Die Supply • Tucker, GA
800 972-2601 • Fax 866-908-9418

email: sales@ccmdie.com

Available Style, size and Application Chart

Style	Sample	Description	Heights	Cut Shapes	Application
95 CORK		<ul style="list-style-type: none"> • Cork and rubber combination • With or without PSA 	3/16", 1/4", 5/16", 3/8"	Sheets, pads, strips, blocks	Highly compressible. Resists fatigue.
80 RED		<ul style="list-style-type: none"> • Open cell sponge • High quality, extra firm density • With or without PSA 	1/8", 3/16", 1/4", 5/16", 3/8", 1/2", 5/8"	Sheets, pads, strips, blocks	Used for cartons, solid fibers, gaskets and labels.
75 RED		<ul style="list-style-type: none"> • Open cell sponge • Extra firm density • With or without PSA 	1/4", 5/16", 3/8"	Sheets, pads, strips, blocks	Used for cartons, solid fibers, gaskets and labels.
73 ORANGE		<ul style="list-style-type: none"> • Open cell sponge • High quality, firm density • With or without PSA 	1/4", 5/16", 3/8", 7/16", 1/2", 9/16", 5/8"	Sheets, pads, strips, blocks	Used for corrugated and cartons.
72 GRAY		<ul style="list-style-type: none"> • Open cell sponge • Firm density • With or without PSA 	3/8"	Sheets, pads, strips, blocks	Used in general diecutting applications, as well as corrugated and cartons.
70 PINK		<ul style="list-style-type: none"> • Open cell sponge • Firm density • With or without PSA 	3/8", 7/16", 1/2", 9/16", 5/8"	Sheets, pads, strips, blocks	Used for corrugated cartons.
68 BLUE		<ul style="list-style-type: none"> • Open cell sponge • Firm density • With or without PSA 	1/4", 3/8"	Sheets, pads, strips, blocks	Used in general diecutting applications, as well as corrugated and cartons.
65 BLACK		<ul style="list-style-type: none"> • Open cell sponge • Medium density • With or without PSA 	1/4", 3/8", 7/16", 1/2", 9/16", 5/8"	Sheets, pads, strips, blocks	Used in general diecutting applications.
60 TAN		<ul style="list-style-type: none"> • Open cell sponge • Medium density • With or without PSA 	1/4", 5/16", 3/8"	Sheets, strips, blocks	Used in general diecutting applications, as well as corrugated and cartons.
57 GRAY		<ul style="list-style-type: none"> • Closed cell • With or without PSA 	3/16", 1/4", 5/16", 3/8", 7/16", 1/2", 9/16", 5/8", 3/4", 7/8", 1"	Sheets, strips, blocks	Primarily used on rotary dies, may be used on flat dies as well.
STRAIGHT GUM		<ul style="list-style-type: none"> • Gum rubber - straight 	1/32", 1/16", 3/32", 1/8", 5/32", 3/16", 1/4"	Sheets, pads, strips	Primarily used in slots.
WAVE GUM		<ul style="list-style-type: none"> • Gum rubber - wave top • Rick Rack 	1/32", 1/16", 3/32", 1/8", 5/32", 3/16", 1/4"	Strips	Primarily used in slots, eliminates compression blow-out on the rule.

FOR PRODUCT INFORMATION AND ORDERS CONTACT:

CCM Die Supply • Martinsburg, WV
800 451-7373 • Fax 866-708-4686

CCM Die Supply • Woodbridge, CT
800 451-7373 • Fax 866-708-4686

CCM Die Supply • Tucker, GA
800 972-2601 • Fax 866-908-9418

email: sales@cmdie.com

5



Monroe Rubber & Plastic, Inc.

Monroe offers a wide variety of ejection materials including open cell, closed cell and specialty materials like **Green G'rilla™**, Neoprene and Stripping Foam. Monroe also features specially-cut shapes like punch rubber (to fit Wagner Punches), **Ejecto-Flex™**, **E-Z-Set™**, and **Side-Wave** Ejectors. Monroe's **Groovy G'rilla™** is a wavy slot rubber designed to provide excellent columnar strength for ejection, while allowing space for compression.

Monroe's E-Z Set™ strips are available in open cell, closed cell and Green G'rilla™ styles. E-Z-Set™ automatically spaces the material accurately from the steel rule for quick die rubbering. E-Z-Set™ ejectors compress without putting pressure against the cutting rule. It helps reduce static charge buildup and nick breakage.

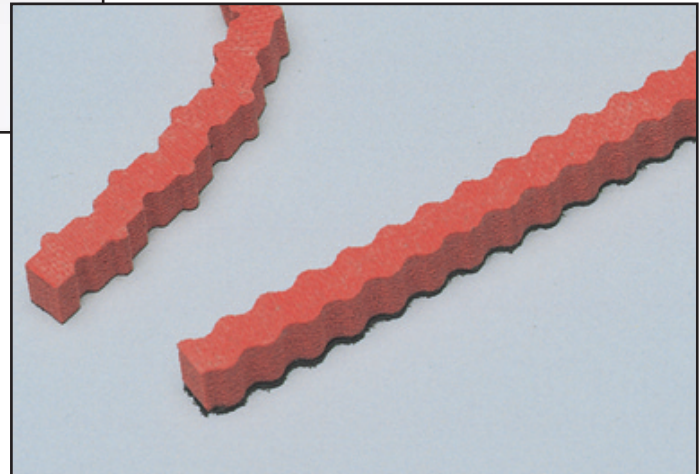

Monroe's Ejectoflex™ and Side-Wave ejectors are designed for quick and easy rubbering of dies. Both Side-Wave and Ejectoflex™ automatically space themselves from the cutting rule. Ejectoflex™, with its unique shape also allows it to easily and precisely conform to curved or bent rule. Ejectoflex™ and Side-Wave are available with pressure sensitive adhesive.

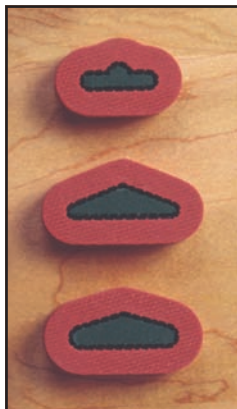

Punch rubber for Wagner seamless hangers.



Punch rubber for Wagner seamless punches.

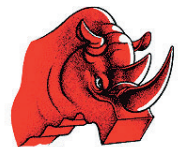
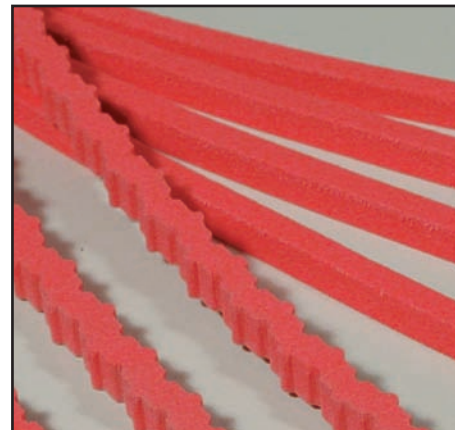

Red Rhino

Red Rhino has a ± 0.020 thickness tolerance. It has the quick kick needed for ejecting thin substrates while having the compressability to handle thicker substrates as well. Red Rhino eliminates crushing materials and overloading the press.

FOR PRODUCT INFORMATION AND ORDERS CONTACT:

CCM Die Supply • Martinsburg, WV
800 451-7373 • Fax 866-708-4686

CCM Die Supply • Woodbridge, CT
800 451-7373 • Fax 866-708-4686

CCM Die Supply • Tucker, GA
800 972-2601 • Fax 866-908-9418

email: sales@cmdie.com

Open Cell Material

Used on flat dies only. Has less compressions set than closed cell. Can be compressed more without cell fracture and loss of integrity.

Available in Sheets, Pads, Strips, Kiss Cut, Loose Pieces and E-Z Set™ Strips.



15700 Soft
Heights Available:
1/4", 3/8", 1/2",
3/4", 1"

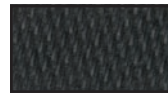

01100 Soft
Heights Available:
1/4", 5/16", 3/8",
7/16", 1/2", 9/16",
5/8", 3/4", 1"

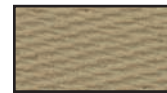

01700 Soft
Heights Available:
1/4", 5/16", 3/8",

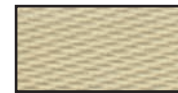

02700 Medium
Heights Available:
1/8", 3/16", 1/4",
5/16", 3/8", 7/16",
1/2", 9/16", 5/8",
3/4", 1"



06500 Firm
Heights Available:
3/16", 1/4", 5/16",
3/8", 7/16", 1/2",
9/16", 5/8"



03500 X-Firm
Heights Available:
1/8", 3/16", 1/4",
5/16", 3/8", 7/16",
1/2", 9/16", 5/8"



14300 Firm
Heights Available:
3/8", 7/16",
1/2", 9/16"

Closed Cell Material

Can be used on either flat or rotary dies. Has a better recovery rate, but more sensitive to compression than open cell. Should not be over-compressed.

Available in Sheets, Pads, Strips, Kiss Cut, Loose Pieces and E-Z Set™ Strips.



12300 Medium
Heights Available:
1/4", 5/16", 3/8",
7/16", 1/2", 5/8",
3/4", 7/8", 1"

Specialty Materials

Specialized materials for stripping, slots and quick ejection applications.

Available in Sheets, Pads, Strips, Kiss Cut, Loose Pieces.

E-Z Set™ Strips only available in Green G'rilla™ and Sponged Cork.

Groovy G'rilla™ only available in pads cut in lengths of 6".



Green G'rilla™
Heights Available:
1/16", 1/8", 3/16"
1/4", 5/16", 3/8",
7/16", 1/2", 9/16",
5/8", 3/4"



07100
Stripping Foam



13500
Sponged Cork
Heights Available:
3/16", 1/4", 5/16",
3/8", 1/2"



Groovy G'rilla™
(wavy slot rubber)
Thicknesses Available:
1/4", 5/16", 3/8"
in widths of
1/8", 3/16", 1/4",
5/16" and 3/8"



Gum
Heights Available:
1/16", 1/8", 3/16"
1/4", 3/8", 1/2"



Monroe Rubber & Plastic, Inc.



Selection Guide - Die ejection materials for flat dies.

Material being die-cut	Rigid		Semi-Rigid		Flexible	
	Thick	Thin	Thick	Thin	Thick	Thin
Compression of Ejection Material	Firm	Extra-Firm	Medium	Firm	Soft	Medium
Ejection Material Placement						
Die Top <input type="checkbox"/>	AFR	AFR	AFR	NTR	NTR	NTR
Die Bottom <input type="checkbox"/>	AFR	AFR	AFR	NTR	NTR	NTR
Type of Cut						
Top <input type="checkbox"/>	Pieces	Pieces	Pieces	Strips	Strips	Strips
Bottom <input type="checkbox"/>	Pieces	Pieces/Strips	Pieces/Strips	Entire Die	Entire Die	Entire Die

AFR = Away From Rule

NTR = Next To Rule

FOR PRODUCT INFORMATION AND ORDERS CONTACT:

CCM Die Supply • Martinsburg, WV
800 451-7373 • Fax 866-708-4686

CCM Die Supply • Woodbridge, CT
800 451-7373 • Fax 866-708-4686

CCM Die Supply • Tucker, GA
800 972-2601 • Fax 866-908-9418

email: sales@cmdie.com

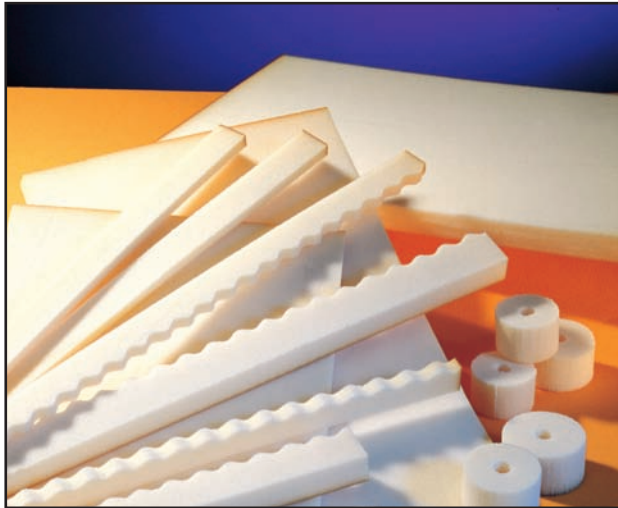

Dura Strip

Made of micro-cellular elastomer, Dura Strip has a low transverse expansion feature that makes it excellent for use in slots and punches. Dura Strip's ability to resist heat makes it ideal for hot board cutting applications.

Dura Strip is available for slots, as trim breaker rubber, and for punch ejectors. It is a proven product that has been successfully used in both rotary and flat dies to solve many of the problems associated with conventional closed cell rubber.

Available in sheets, straight or scalloped strips in a variety of thicknesses.

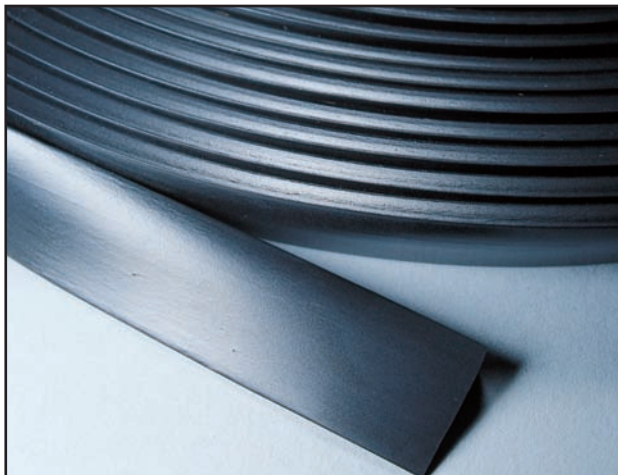

Kushion Crease

Designed to reduce fractured scores sometimes caused by diecutting dry or recycled board. Kushion Crease gently crushes the inner liner and the medium, assisting the scoring rule to form an accurate crease on all grades of corrugated (from E-Flute to Tri-Wall).

Easily applied to existing dies by gluing or tacking. Available in lengths or coils with heights of .175, .200, .225, .250, .275, .295, .300, .315, .325, .335, .355, .370, .380 and .390

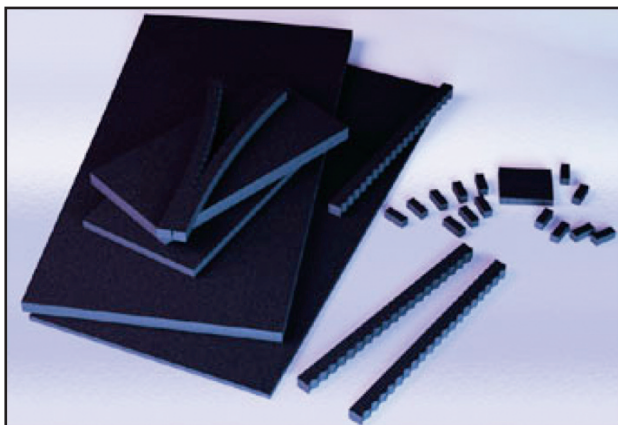

Supercel 85

PACKAGING

Sheet sizes	5" (127mm) x 10" (254mm)	Sold by the box
	10" (254 mm) x 20" (508mm)	Sold by the sheet

Thickness (in.):	1/8	3/16	1/4	5/16	3/8	7/16	1/2	9/16	5/8
Thickness (mm):	3.18	4.75	6.35	7.92	9.52	11.10	12.7	14.27	15.88
Sheets Per Box:	16	12	8	8	6	4	4	4	4

FOR PRODUCT INFORMATION AND ORDERS CONTACT:

CCM Die Supply • Martinsburg, WV
800 451-7373 • Fax 866-708-4686

CCM Die Supply • Woodbridge, CT
800 451-7373 • Fax 866-708-4686

CCM Die Supply • Tucker, GA
800 972-2601 • Fax 866-908-9418

email: sales@ccmdie.com

Profile Shaped Rubber

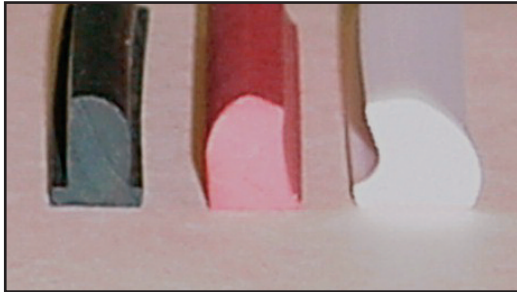

The result – using Nick Rubber means faster press speeds with fewer nicks!

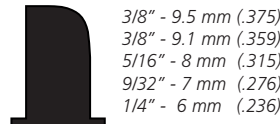

Nick Rubber
Black 60-65
Durometer

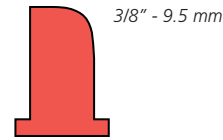

Nick Rubber
Red 45-50
Durometer

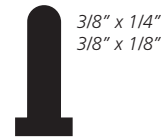

Slot "T" Rubber
Black 60-65
Durometer

Profile Shaped Rubber is generally used in the nicked areas or in slots of the cutting die. **Nick Rubber** is placed on the sheet feed side of knife so the rubber will roll into the nick, creating a strong hold during the diecutting process. This product also helps in preventing blanks from separating at the nicks and causing jams and delays. Also available in white when "marking" is a factor. **Slot "T" Rubber** is made from 100% natural rubber and it's special profile is designed primarily for use in slots.

Stripping Foam



Gray 6 lb. Stripping Foam 1-1/2" x 1-5/8" x 40"L (28 pieces per box). For versatility may be trimmed to accommodate both sizes.

Kushion Kick

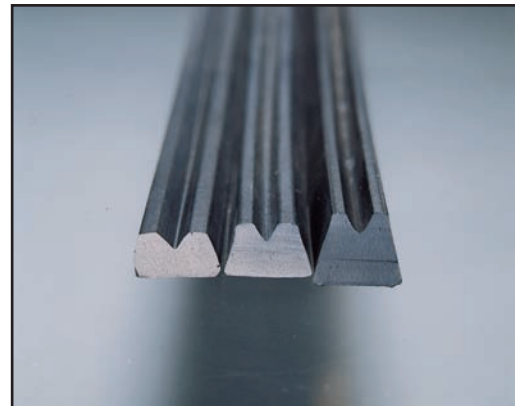

40 (+5) Durometer – Extruded EPDM Solid Rubber Black
Heights – 1/4", 5/16", 3/8"
Packaging – 24" Lengths - 100 FT per box

SuperSet

EXCLUSIVE



Cyanoacrylate adhesive (Super Glue). Used on flat and rotary dies. Use on rubber having a smooth, non-porous surface like Dieprene, Profile Rubber, etc. Available in high or low viscosity. Holds extremely tight. Available in 1 oz. and 1 lb. bottles. Store in a cool area out of direct sunlight. Refrigeration up to 40°F gives optimum storage stability.

High Viscosity - 15-40 seconds cure time
Superset I 3,000 to 3,700 p.s.i. shear strength

Low Viscosity - 5-15 seconds cure time
Superset II 2,500 to 3,495 p.s.i. shear strength
Superset III

Full cure time for both - 24 hours @ 68°F

SuperSet Remover - Available in a 2 oz. bottle

Superset Gel - Available in 20 gram tube and 200 gram tube

FOR PRODUCT INFORMATION AND ORDERS CONTACT:

CCM Die Supply • Martinsburg, WV
800 451-7373 • Fax 866-708-4686

CCM Die Supply • Woodbridge, CT
800 451-7373 • Fax 866-708-4686

CCM Die Supply • Tucker, GA
800 972-2601 • Fax 866-908-9418

email: sales@cmdie.com

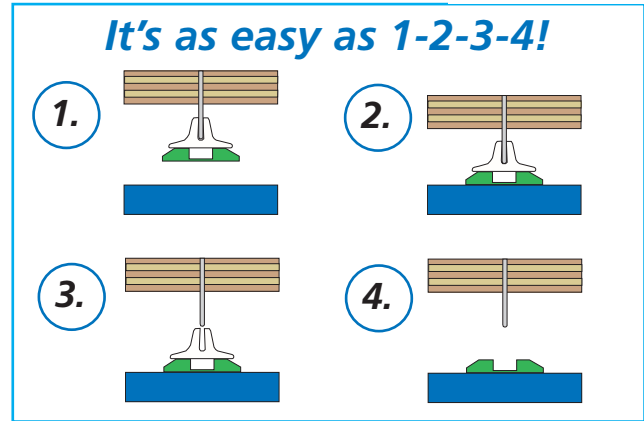

Boxed quantities:

#24 to #105 matrix – 48 feet per box.

#120 to #250 and double crease matrix – 24 feet per box.

Matrix Types



Standard Center Crease
is used for a Single Crease and is suitable for board thicknesses from .003" to .070".



Off-Center Crease
can be combined to form a double crease or used where a cutting rule is close to the creasing rule. Available in #40-OC, #50-OC & #60-OC.



Double-Crease Matrix
is used for multiple creases such as file folders and brochures. Center to center dimensions of the channels are 1/8", 3/16" and 1/4" in #50. Also available in 1/4" in #60.



Reverse Crease Matrix
acts as the male rule and is used to accomplish crease in reverse. Two rules in the die act as the channel. See CCM catalog for sizes.

Selection Chart for Matrix and Creasing Rule.

Paperboard Thickness	Matrix Size For 1pt.	Matrix Size For 2pt.	Matrix Size For 3pt.	Matrix Size For 4pt.	Matrix Size For 6pt.	Crease Height Using .937 Cut	Crease Height Using .918 Cut
.006	24	40	-	-	-	.921	.902
.008	24	40	-	-	-	.919	.900
.010	32	50	-	-	-	.917	.898
.012	-	50	67	-	-	.915	.896
.014	-	50	67	-	-	.913	.894
.016	-	60	67	-	-	.911	.892
.018	-	60	75	-	-	.909	.890
.020	-	67	75	-	-	.907	.888
.022	-	67	83	-	-	.905	.886
.024	-	75	83	-	-	.903	.884
.026	-	-	90	-	-	.901	.882
.028	-	-	90	-	-	.899	.880
.030	-	-	90	-	-	.897	.878
.032	-	-	105	-	-	.895	.876
.034	-	-	105	-	-	.893	.874
.036	-	-	105	120	-	.891	.872
.038	-	-	-	120	-	.889	.870
.040	-	-	-	120	-	.887	.868
.044	-	-	-	150	-	.883	.864
.048	-	-	-	150	-	.879	.860
.052	-	-	-	150	-	.875	.856
.056	-	-	-	200	-	.871	.852
.060	-	-	-	200	-	.867	.848
.064	-	-	-	200	200-250	.863	.844
.068	-	-	-	200-250	200-250	.859	.840
.072	-	-	-	200-250	200-250	.855	.836

The column that appears first in a particular row is the size of matrix and creasing rule recommended for best results with the perfect board. Some changes may be necessary due to board variation due to moisture content.

FOR PRODUCT INFORMATION AND ORDERS CONTACT:

CCM Die Supply • Martinsburg, WV
800 451-7373 • Fax 866-708-4686

CCM Die Supply • Woodbridge, CT
800 451-7373 • Fax 866-708-4686

CCM Die Supply • Tucker, GA
800 972-2601 • Fax 866-908-9418

email: sales@cmdie.com

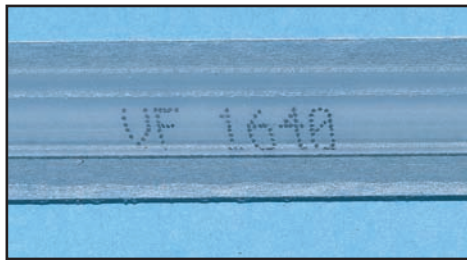

All Marathon Matrix VF™ comes labeled with sizing information right on the product, for easy identification.



Go on a "time diet", with Marathon Matrix VF™!

Marathon Matrix VF™ assures quick and easy makeready, reliable and accurate registration, and a high quality crease, run, after run, after run.

With its vulcanized fiberboard construction, Marathon Matrix VF™ allows for unsurpassed durability and registration for runs short or long.

Marathon Matrix VF Fiberboard Chart

Marathon Matrix VF™ is a vulcanized fiber matrix that allows you long runs with minimal base material. Allowing you a lower profile for faster run speeds. Self-locating using a thermal bonding process, there is no messy residue from the adhesive after detaching the locator. The following chart is for calculating which size of matrix to be used depending on the paperboard thickness you are using and the width of crease rule used.

Paperboard Thickness	Matrix size 1pt crease	Matrix size 2pt crease	Matrix size 3pt crease	Deeper size Matrix	Crease rule Height **
.008	1224 (0.3 x 0.6)	1240 (0.3 x 1.0)		1640 (0.4 x 1.0)	.924
.010	1232 (0.3 x 0.8)	1248 (0.3 x 1.2)		1648 (0.4 x 1.2)	.922
.012		1248 (0.3 x 1.2)		1648 (0.4 x 1.2)	.920
.014		1652 (0.4 x 1.3)		2052 (0.5 x 1.3)	.918
.016		1656 (0.4 x 1.4)		2056 (0.5 x 1.4)	.916
.018		2060 (0.5 x 1.5)		2460 (0.6 x 1.5)	.914
.020		2064 (0.5 x 1.6)		2464 (0.6 x 1.6)	.912
.022		2468 (0.6 x 1.7)	2480 (0.6 x 2.0)	2880 (0.7 x 2.0)	.910
.024		2472 (0.6 x 1.8)	2890 (0.7 x 2.3)	3290 (0.8 x 2.3)	.908
.026			2890 (0.7 x 2.3)	3290 (0.8 x 2.3)	.906
.028			3290 (0.8 x 2.3)	4090 (1.0 x 2.3)	.904
.030			32100 (0.8 x 2.5)	40100 (1.0 x 2.5)	.902
.032			32110 (0.8 x 2.8)	40110 (1.0 x 2.8)	.900
.034			32110 (0.8 x 2.8)	40110 (1.0 x 2.8)	.898

**Crease rule height is determined by using the formula of:
(Cutting rule - paper board thickness) - .005
With the assumption of the cutting rule being .937

The formula used to obtain the proper matrix size in the chart was:
(Paper board thickness x 1.75) + crease rule width

The numbering system for the sizes correlates to the depth and width of the matrix channel. The first 2 numbers represent the depth of channel and the numbers that follow are representative of the channel width. In some circumstances it may be necessary to have some extra depth, the recommended extra depth is provide in the chart. If other sizes are necessary please contact us for availability.

Marathon Matrix VF™ Corrugated

The following chart is for using the Marathon Matrix VF on corrugated material. Please note, due to the variations of materials used to make the different fluted materials, we are using crushed thickness to decide which matrix to use. Crushed thickness can change even on the same fluted material due to changes in liner thickness and/or medium thickness as well as the additions of laminates.

Crushed Thickness	Matrix Size 3pt	Deeper 3pt	Matrix Size 4pt	Crease Rule Height**
.030	32100 (0.8 x 2.5)	40100 (1.0 x 2.5)		.902
.032	32110 (0.8 x 2.8)	40110 (1.0 x 2.8)		.900
.034	32110 (0.8 x 2.8)	40110 (1.0 x 2.8)		.898
.036	40110 (1.0 x 2.8)		40136 (1.0 x 3.4)	.896
.038			40136 (1.0 x 3.4)	.894
.040			40136 (1.0 x 3.4)	.892
.042			40136 (1.0 x 3.4)	.890

** Crease Rule height is determined by using the assumption of a cutting rule height of .937. Again the formula used was (cutting rule height - crushed board thickness - .005)

Please note that it is essential that we determine the crushed board thickness by the use of either of the following methods;

1. Crushing the corrugated with a micrometer gauge (not a dial caliper since they have a tendency to cut through the paper) The gauge should have flat edges to crush the material properly.
2. Find the size of the liners adding them together with the medium and any laminate if appropriate.

The formula used to determine the proper channel width was;

$$2x \text{ crushed board thickness} + \text{crease rule width}$$

Note this formula is different than that used in fiberboard, it is not necessary to delaminate corrugated paper as it is with fiberboard.

Although you will find this chart to be fairly accurate in calculating the size of the matrix you need, there are variations in board quality, moisture content, and coatings that affect the bending characteristics when these exceptions arise some experimentation may be necessary. Fast, accurate additional help can be obtained by calling **800-451-7373**.

FOR PRODUCT INFORMATION AND ORDERS CONTACT:

CCM Die Supply • Martinsburg, WV
800 451-7373 • Fax 866-708-4686

CCM Die Supply • Woodbridge, CT
800 451-7373 • Fax 866-708-4686

CCM Die Supply • Tucker, GA
800 972-2601 • Fax 866-908-9418

email: sales@cmdie.com



PLASTRIX™ is a tough, polymer matrix with a specially tapered edge that allows for high press speeds **WITHOUT TAPING!**

PLASTRIX™ features a unique radius-profile that **REDUCES DRAW** on material being scored.

PLASTRIX™ matrix is produced with an accurate, thermally-bonded locator system - **NO ADHESIVE RESIDUE TO REMOVE!**

PLASTRIX™ has a specially-formulated non-migrating adhesive that **STAYS PUT FOR THE DURATION OF THE RUN!**

PLASTRIX™ can't come apart and is not affected by moisture via condensation or humidity - **IT'S TOUGH, SAVES YOU TIME AND MAXIMIZES PRODUCTION!**

PLASTRIX™ is color-coded for **EASY RECOGNITION** on the shelf and on the press!

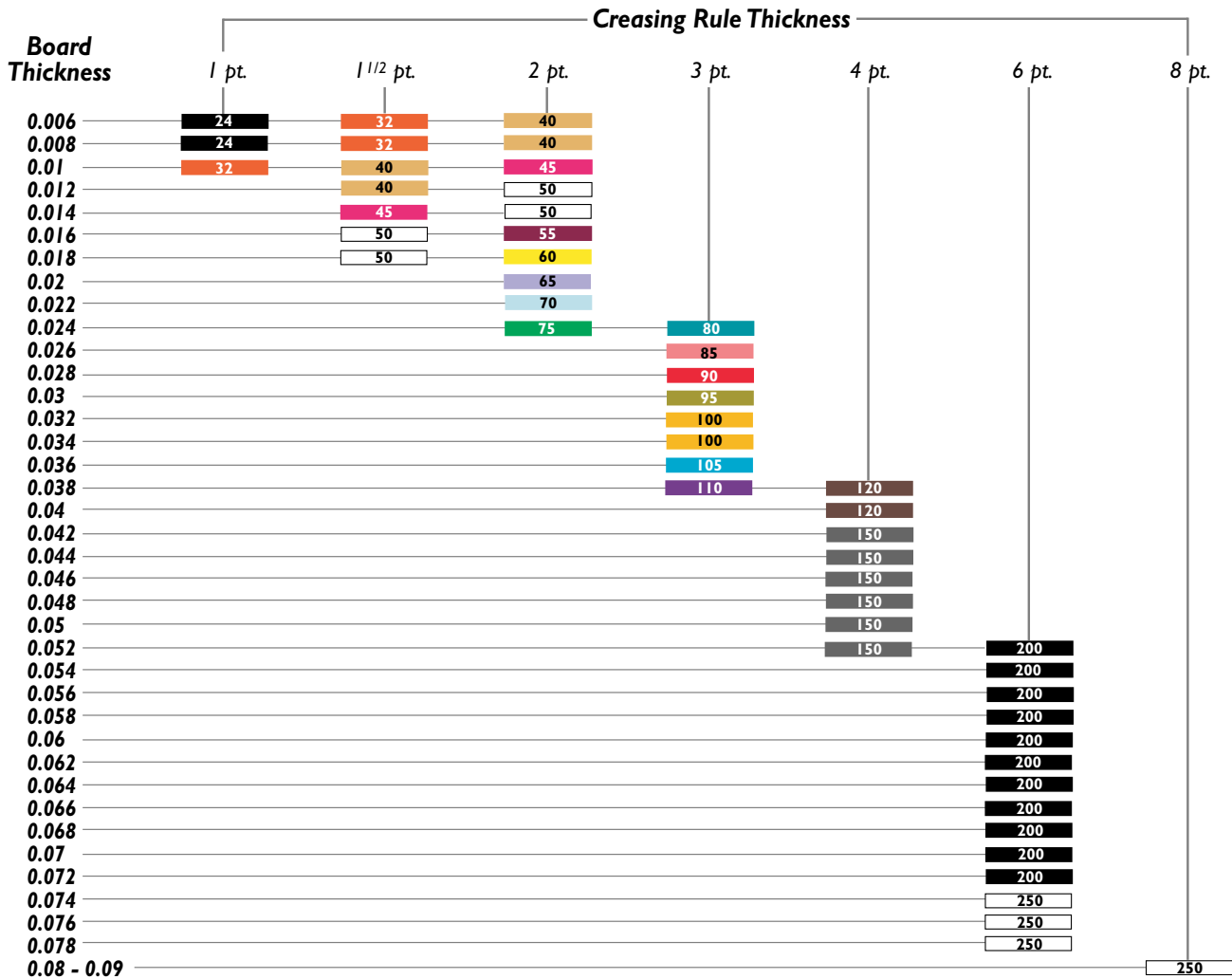

HEIGHT FORMULA:

CUTTING RULE HEIGHT minus BOARD THICKNESS minus .005 (for 1/2") or .010 (for 1/4") = creasing rule height.

FOR PRODUCT INFORMATION AND ORDERS CONTACT:

CCM Die Supply • Martinsburg, WV
800 451-7373 • Fax 866-708-4686

CCM Die Supply • Woodbridge, CT
800 451-7373 • Fax 866-708-4686

CCM Die Supply • Tucker, GA
800 972-2601 • Fax 866-908-9418

email: sales@ccmdie.com

CCM Bench Press



Miters on two ends at the same time. Reversible cutting anvil for long life, and guides for 1/4" and 1/2" width matrix.

CCM Straight Cut Pliers



Economical cutting pliers for all sizes of Channel Creasing® Matrix.

Dolphin Cutters



Angled shear for rubber or matrix



**CHANNEL®
CREASING MATRIX, INC.**

Fit® Shim Tape



Hardened steel, .0015" x 5/16" x 33' rolls.

Accu-Shim® Tape

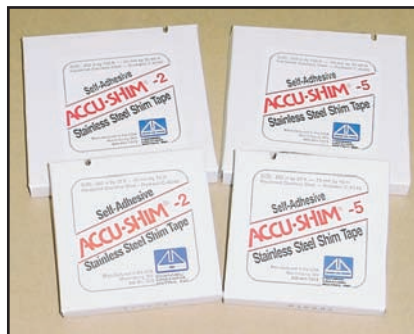

Stainless steel. .002" x 5/16" or .005" x 5/16" - available in both 33' and 100' rolls.

Cutting Plate Cleaner II



Cutting Plate Cleaner II is recommended for plate cleaning prior to using matrix. Residue-free and quick drying, allows matrix to adhere properly. Available in 1 gallon can, 5 gallon pail and 55 gallon drum.

FOR PRODUCT INFORMATION AND ORDERS CONTACT:

CCM Die Supply • Martinsburg, WV
800 451-7373 • Fax 866-708-4686

CCM Die Supply • Woodbridge, CT
800 451-7373 • Fax 866-708-4686

CCM Die Supply • Tucker, GA
800 972-2601 • Fax 866-908-9418

email: sales@cmdie.com

Bar-Plate Low Profile Adjusto Guides

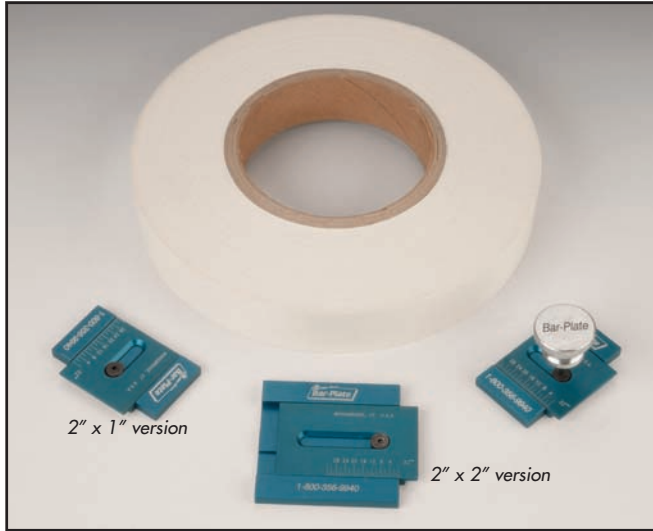

The fastest and most accurate way to achieve register. These guides are fully adjustable and are available in 2" x 2" and 2" x 1" sizes. The guides provide plenty of frontal surface and a lip to keep stock from rising. Adjusts with custom Allen tool included. Guides are available individually or in sets of three in either 2" x 2" or 2" x 1" version, set includes a 1" wide roll of double-sided tape. **Standard Adjusto Guides**, (not pictured) that will accommodate all materials up to 1/2" in thickness, are also available either individually or in sets with 2" double-sided tape included.

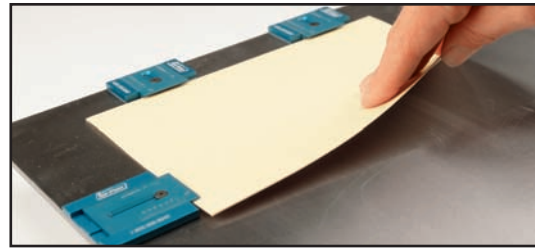

Stop Guides



Plastic, two-piece. For use on clam shell type cutting presses to register stock.

Wood Furniture

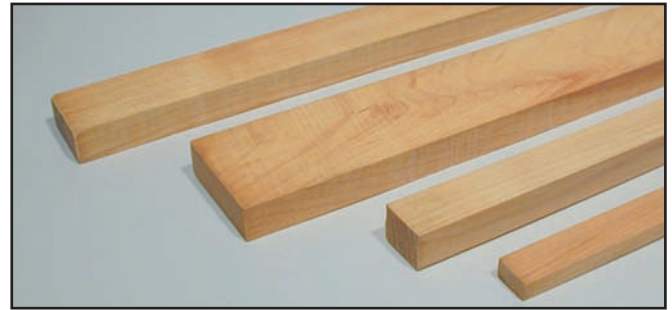

Used to take-up space and provide stable lock-up for quoin. Available in 36" lengths, 5/8" tall, in a variety of picas.

Quoins & Keys

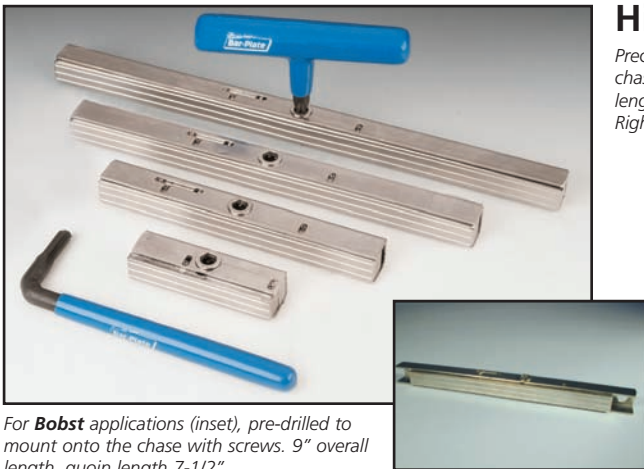

For **Bobst** applications (inset), pre-drilled to mount onto the chase with screws. 9" overall length, quoin length 7-1/2".

High-Speed Quoins

Precision lock-up for locking up die into chases. Available in 3", 6", 9" and 12" lengths. One piece T-handle or 6" Right Angle Quoin Keys can be ordered.

Torque Key



Specially designed to prevent damage to Quoins from over-tightening. Factory-preset to provide the manufacturer recommended torque. Replaceable key drive heads available as shown.

Economy Quoin and Key

This 3-inch Quoin features a reliable wedge locking system. Quality lock-up at a reasonable price.

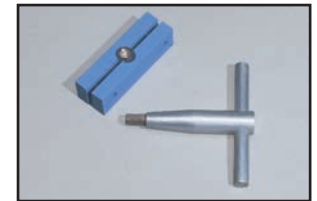

FOR PRODUCT INFORMATION AND ORDERS CONTACT:

CCM Die Supply • Martinsburg, WV
800 451-7373 • Fax 866-708-4686

CCM Die Supply • Woodbridge, CT
800 451-7373 • Fax 866-708-4686

CCM Die Supply • Tucker, GA
800 972-2601 • Fax 866-908-9418

email: sales@ccmdie.com

Phenolic Material

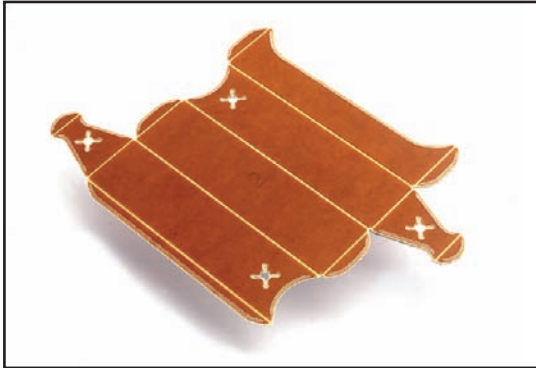

A pre-cut counter machined from Phenolic Material.

Available in a rigid or flexible material which is machine routed to create a reusable counter for long runs. Available sizes from .017" to .048" thick in sheet size of 39"x 39" (1 meter square).

Counterplate Pin & Ring



These reusable, plastic pins and rubber rings are designed for pre-made counters used as locators to transfer counters from cutting dies to cutting plate for exact registration.

Thickness Gauge

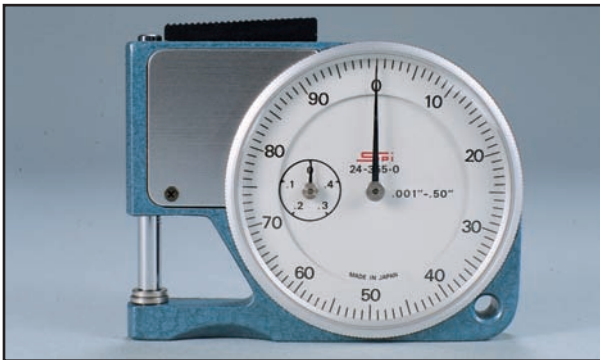

This small and accurate unit features .0005" graduations and comes complete with vinyl storage pouch. Used for measuring thickness of paper board stock.

Bundling Gloves



These heavy-duty gloves are durable as well as comfortable. Available in left and right hand versions.

Ring Knives



Available in the following ring sizes: 5, 6, 7, 8, 9, 10, 11 and 12.

Bar-Plate Multi-Cutter Jr.



Cuts strip rubber cleanly and accurately, as well as other non-metallic materials like Marathon Matrix VF™ and tapes.

Steel Stop Pins



Precision ground, solid steel stop pins help protect steel rule die from damage as a result of uneven press conditions.

FOR PRODUCT INFORMATION AND ORDERS CONTACT:

CCM Die Supply • Martinsburg, WV
800 451-7373 • Fax 866-708-4686

CCM Die Supply • Woodbridge, CT
800 451-7373 • Fax 866-708-4686

CCM Die Supply • Tucker, GA
800 972-2601 • Fax 866-908-9418

email: sales@cmdie.com

Counterboard



Counterboard is available in a variety of types. **Vulcanized Fiber** (red in color) with its extra-hard construction throughout is ideal for long runs, or when recycled board is used as a substrate. **Genuine Pressboard** (pearl gray in color) with its hard surface is best suited for medium length runs. It's hard edge allows for a clean square channel that helps define the crease or score. Manila colored **Jute Tag** (not pictured) with its medium hardness, is ideally suited for short run applications.

Both Genuine Pressboard and Jute Tag are available in plain, self-adhesive or kraftback versions

Score Cutting and Skiveready Knives



Scoring Knife - (Top) Features precision construction for rugged durability. Designed to cut channels in counterboard. Comes complete with 2 blades and 9 shims in a custom storage case.

Skiveready Knife - (Bottom) Rugged all-aluminum construction, designed specifically for skiving the counterboard. Comes complete with one center bevel blade.

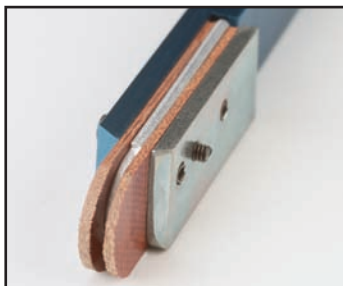

Adjustable Sample Maker's Score Cutting Tool

Similar to Score Cutting Knife, it is designed to make a wide range of sample scores using its 2 fiber blades and set of 13 shims. The ultimate hand sample making tool.



Sample Maker's Creasing Rule Holder

Used along with the above Scoring Tool, holds any point scoring rule in place for easy, fast hand-scoring of samples.

Corrugated Box Score Cutting Knife

Comes complete with two blades and 13 shims to create channel widths from .010" to 3/8".



FOR PRODUCT INFORMATION AND ORDERS CONTACT:

CCM Die Supply • Martinsburg, WV
800 451-7373 • Fax 866-708-4686

CCM Die Supply • Woodbridge, CT
800 451-7373 • Fax 866-708-4686

CCM Die Supply • Tucker, GA
800 972-2601 • Fax 866-908-9418

email: sales@ccmdie.com

Cutting Plates and Cutting Jackets



These high quality Cutting Plates and Jackets are manufactured by Bar-Plate Mfg. Co. for Bobst, Thompson, Zerand, Mercury, Heidelberg, Meihle and many other press manufacturers. See Bar-Plate catalog for available sizes. Steel Chases are also available.

Patch Tape



Patch Tape is a self-adhesive patching make-ready tape. Available in .001 Blue, .002 Red and .003 Yellow with 25m length (6mm wide).

Double Face Tape



Used for adhering counterboard to cutting plate. 2" x 36 yds., 6" x 36 yds. or 12" x 36 yds. rolls.

Stiki Tape



A self adhesive make ready tape. Available in .001 grape, .002 green and .003 orange with 108' per roll (6mm wide).

Makeready Tape



.0015" transparent glassine, .003" translucent white kraft or .006" natural kraft. Optional dispenser for all three tape sizes in the 1/4" or 1/2" available widths.

FOR PRODUCT INFORMATION AND ORDERS CONTACT:

CCM Die Supply • Martinsburg, WV
800 451-7373 • Fax 866-708-4686

CCM Die Supply • Woodbridge, CT
800 451-7373 • Fax 866-708-4686

CCM Die Supply • Tucker, GA
800 972-2601 • Fax 866-908-9418

email: sales@ccmdie.com

Air Stripping Hammer, Muffler and Chisels



Quickly strips and separates diecut skidded loads. Available with muffler to reduce DBA level on average 8-10 DBA.

Model	Chisel	Overall Length	O.D. Body	Collar	Shank
A-1	Offset	18"	3/4"	oval or round	round
A-1	Straight	18"	3/4"	oval or round	round
A-2	Offset	18"	5/8"	oval or round	round
A-2	Straight	18"	5/8"	oval or round	round
B-1	Straight	18"	5/8" x 5/8"	oval or round	round
C-1	Cutter	14"	1-1/4"	oval or round	hex

Waste Trim Stripper



2-speed, air-powered waste stripper features hardened circulating stripping chain, shielded hand grip and chain guard for safety. Saves time and money!

Air Tool Balancer



Allows for easy overhead installation of air tools. Supports tools weighing 5 to 20 lbs. Excellent for use with the Wagner Extractor 3000.

Stripping Hammer



Designed for stripping waste and trim by hand. Replacement rubber tips available.



safety

The "Grabber"

The Grabber, a Wagner Die Supply exclusive, is a simple and effective safety device. The Grabber enables press operators to remove debris and stripping remnants from the press safely, **without leaning into or entering the press**. The Grabber virtually eliminates the hazards of operator contact with sharp stripping pins and steel rule. Easy to use and durable, the rubber tipped, stamped steel jaws close by squeezing the handle. Available in two sizes, 36" and 51".



FOR PRODUCT INFORMATION AND ORDERS CONTACT:

CCM Die Supply • Martinsburg, WV
800 451-7373 • Fax 866-708-4686

CCM Die Supply • Woodbridge, CT
800 451-7373 • Fax 866-708-4686

CCM Die Supply • Tucker, GA
800 972-2601 • Fax 866-908-9418

email: sales@cmdie.com

SERVO Mega Form

SWISS MADE BY **SERVO**® HANDELS & WERBE AG



Creasing Counter Channel Cutting Machine.

The Wagner Supply Group is proud to carry the complete SERVO product line.

Featured in this section is the SERVO Mega Form, Mini SERVO, SERVO Baby and Torque Leader. All SERVO equipment feature world-class design unsurpassed quality, and ease of operation with superior results. Other SERVO equipment includes: The SERVO Super Quick nick grinder and the SERVO Tornado Waste Stripper (not pictured).

The SERVO Super Quick nick grinder is featured in the Die Room Equipment section of this catalog.

Mini SERVO



Hand Milling Cutter for proper trimming of angles.

Torque Leader



Accurately torques die in chase. Head trips when proper torque setting is achieved.

SERVO Baby



Designed to perfectly chamfer the counters edges.

MA Series III Cutting Press

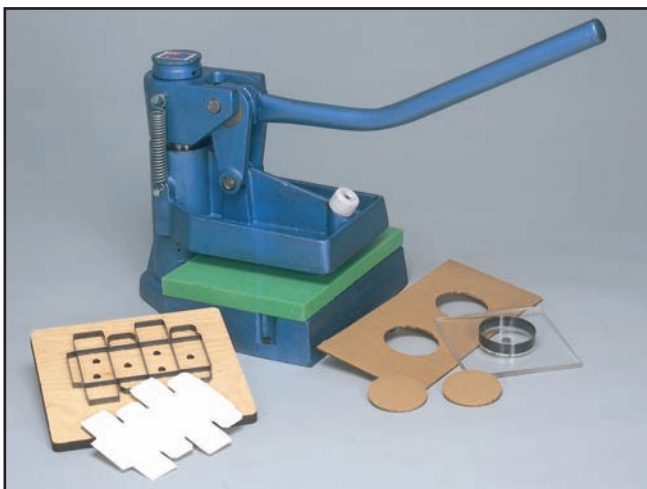

The MA Series III Cutting Press has a cutting pad size of 8-3/4" x 11-3/4" x 1" thick, and can generate a maximum of 4 tons of pressure. The press can be adjusted for steel rule heights of .750 to 1.500. As rule heights increase, the cutting pad thickness must be reduced.

Manufactured in Australia, and introduced by Steel Rule Distributors of Australia, the MA Series III cutting press is a well-designed and compact press great for short-run diecutting. Ruggedly constructed, the MA Series III features a cam actuated mechanism that makes it easy to operate.

Well suited for the cutting of leather, embroidery, badges, corrugated, cloth, card stock, wood, felt and plastic products, the MA Series III can use a variety of dies from traditional steel rule dies to clicker dies.



Convenient swing arm design allows for easy viewing of materials and dies.

FOR PRODUCT INFORMATION AND ORDERS CONTACT:

CCM Die Supply • Martinsburg, WV
800 451-7373 • Fax 866-708-4686

CCM Die Supply • Woodbridge, CT
800 451-7373 • Fax 866-708-4686

CCM Die Supply • Tucker, GA
800 972-2601 • Fax 866-908-9418

email: sales@cmdie.com

Channel® Creasing Matrix, Inc. CCM Die Supply

Providing top quality products, services and technical assistance that meet or exceed our customers expectations. Our ability to do this comes from internal and external training resources, while continually improving growth and prosperity for our customers, employees and community.



FOR PRODUCT INFORMATION AND ORDERS CONTACT:

CCM Die Supply • Martinsburg, WV
800 451-7373 • Fax 866-708-4686

CCM Die Supply • Woodbridge, CT
800 451-7373 • Fax 866-708-4686

CCM Die Supply • Tucker, GA
800 972-2601 • Fax 866-908-9418

[email: sales@cmdie.com](mailto:sales@cmdie.com)

Leading Edge Service –

The right products, the right price, right on time!



CCM

Die Supply

531 Corning Way, Martinsburg, WV 25401

Toll-Free (800) 451-7373

(304) 263-0954 • Fax: (304) 263-2897

Toll-Free Fax Ordering: (866) 708-4686

Northeast Shipping Point - Woodbridge, CT



CCM

Die Supply

2615 Mountain Industrial Blvd., Unit 4, Tucker, GA 30084

Toll-Free (800) 972-2601

(770) 908-9418 • Fax: (770) 908-9418

Toll-Free Fax Ordering: (866) 908-9418



WDS

West

2041 Elm Court, Ontario, CA 91761

Toll-Free (800) 423-4478

(909) 947-3044 • Fax: (909) 923-7809

Toll-Free Fax Ordering: (866) 786-2437
P-U-N-C-H-E-S

Northwest Shipping Point - Tacoma, WA



WDS

South

2532 Converse Street, Dallas, TX 75207

Toll-Free (800) 262-4695

(214) 630-4695 • Fax: (214) 630-5425

Toll-Free Fax Ordering: (800) 446-6651



WDS

Mid-West

960 Industrial Drive, Unit 8, Elmhurst, IL 60126

Toll-Free (800) 334-7914

(630) 782-6230 • Fax: (630) 782-6220

Toll-Free Fax Ordering: (800) 554-9124

Visit us on the web: www.ccmdie.com



CCM Die Supply works in unison with Wagner Die Supply. This allows us the ability to reach 99% of the U.S. Population within 1-2 days Ground UPS.