

Under Counter Freezer

With Side Mounted Compressor



Features

- CFC free refrigerant and foam insulation.
- Equipped with an electronic thermostat and digital LED temperature display for precise control and convenient reading.
- Features a self-closing swing door for added convenience.
- The magnetic gasket can be replaced without the need for any tools.
- External construction comprises stainless steel framework.
- Internally constructed with 304 stainless steel.
- Incorporates auto defrosting and auto evaporation mechanisms to prevent condensation.
- The coated copper tube, boasting a sturdy 0.7mm thickness, ensures durability.
- Crafted from a single bent tube, minimizing the risk of leaks with only two welding joints.
- The condenser is efficiently positioned inside the condensation pan to facilitate the evaporation of excess water.
- Adjustable and heavy-duty epoxy-coated wire shelves for flexible storage options.
- Comes with easy-to-mount 4" casters (front casters equipped with brakes), standard with all units.
- Electrical specifications: 115/60/1 with a NEMA 5-15P plug and a 10ft cord.

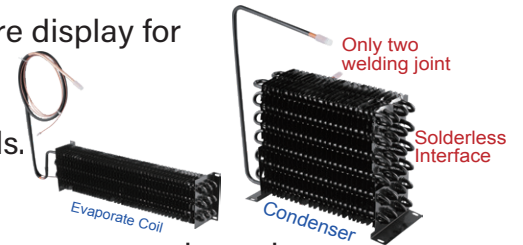

Temperature

- Interior temperature range: -17°C to -23°C (0°F to -10°F)
- Ambient temperature upto 45°C (113°F)

Warranty

- 3 years parts and labour
- 5 years compressor warranty



CUSC-60F
CUSC-72F



CUSC-48F



CUSC-84F
CUSC-96F

Specifications

Model	Doors	Ext. Dimensions W x D x H (in)	Shelves	V/Hz/Ph	AMPS	Power	Storage Capacity(cu./ft)	NEMA PLUG	Ship Weight(lbs)	Ship Data W x D x H (in)
CUSC-48F	1	48 1/4" x 31 1/2" x 35 1/2"	2	115/60/1	4	380W/0.51 HP	9.5	5-15P	288	51 3/8 x 35 1/4 x 39 1/4
CUSC-60F	2	60" x 31 1/2" x 35 1/2"	2	115/60/1	5	450W/0.61 HP	14.2	5-15P	346	63 1/2 x 35 1/4 x 39 1/4
CUSC-72F	2	72" x 31 1/2" x 35 1/2"	2	115/60/1	5.5	500W/0.67 HP	19	5-15P	410	75 1/2 x 35 1/4 x 39 1/4
CUSC-84F	3	84" x 31 1/2" x 35 1/2"	2	115/60/1	7.5	600W/0.81 HP	23.4	5-15P	463	87 1/2 x 35 1/4 x 39 1/4
CUSC-96F	3	96" x 31 1/2" x 35 1/2"	2	115/60/1	7.5	600W/0.81 HP	27.7	5-15P	501	99 1/2 x 35 1/4 x 39 1/4

If the data and structure update,
without notice, subject to material object.

Under Counter Freezer

With Side Mounted Compressor



CUSC-48F

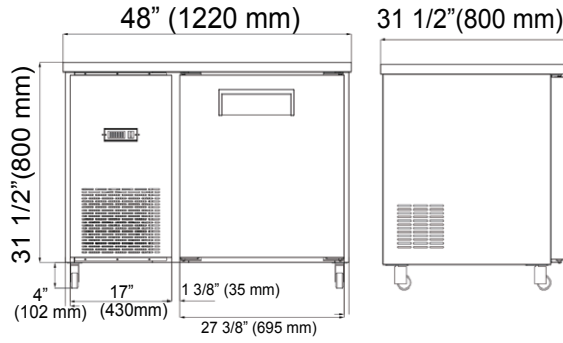

CUSC-60F
CUSC-72F

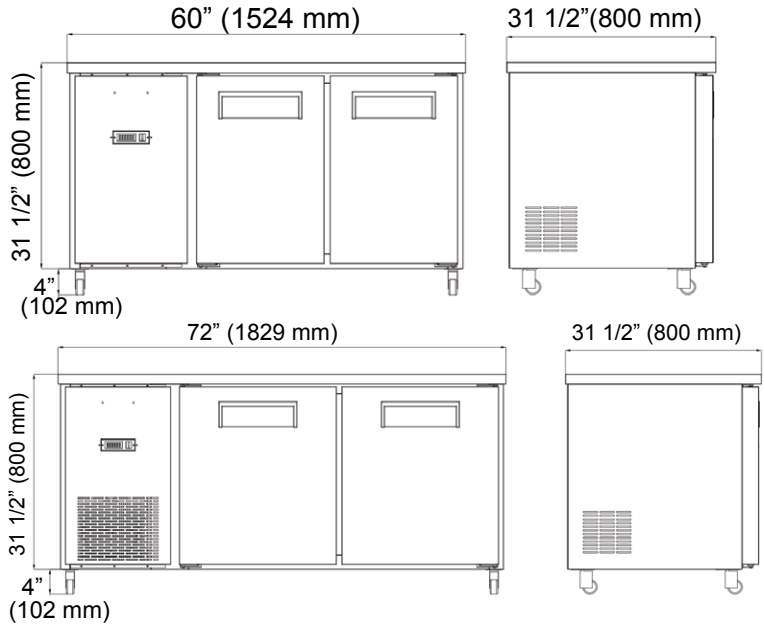

CUSC-84F
CUSC-96F

