

# ELECTRIC CONVECTION OVENS



TR-COE



TR-COE with TR-CO-LK

## PRODUCT FEATURES:

- Full size electric convection oven
- 10 kW of heating power, 208V/3PH
- Independent glass window doors
- 2-speed, ½ HP fan motor (1725, 1140 rpm)
- Forced 'cool down' fan mode • Porcelain enamel oven interior
- Electronic thermostat (FAST) & manual timer control
- Temperature range: 150°-500°F ( 66°-260°C )
- Stainless steel front, sides, & top exterior
- Control panel located on right side, pull down drawer, away from burners
- 2 halogen interior lights, easy to service
- 5 nickel plated racks, 10 rack positions
- Single oven – leg kit including 430 s/s pressure blasted surface, 4" casters w/ brake & 2" adjustable bullet feet (ORDERED SEPARATELY)
- Double oven – stacking kit w/ 5" casters (ORDERED SEPARATELY)

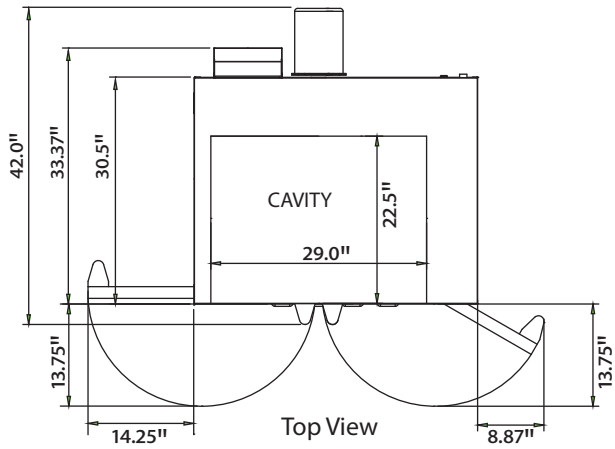

## Electric Convection Oven Product Specifications

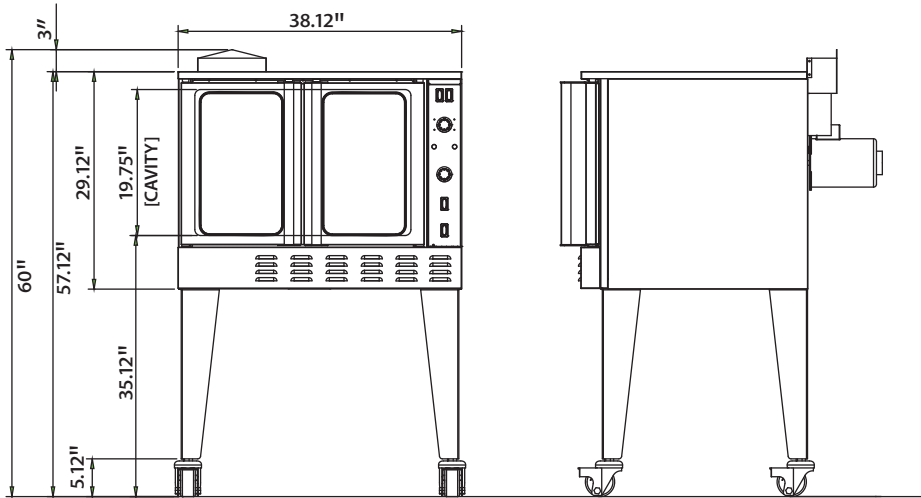

Single Oven with Leg and Caster Kit

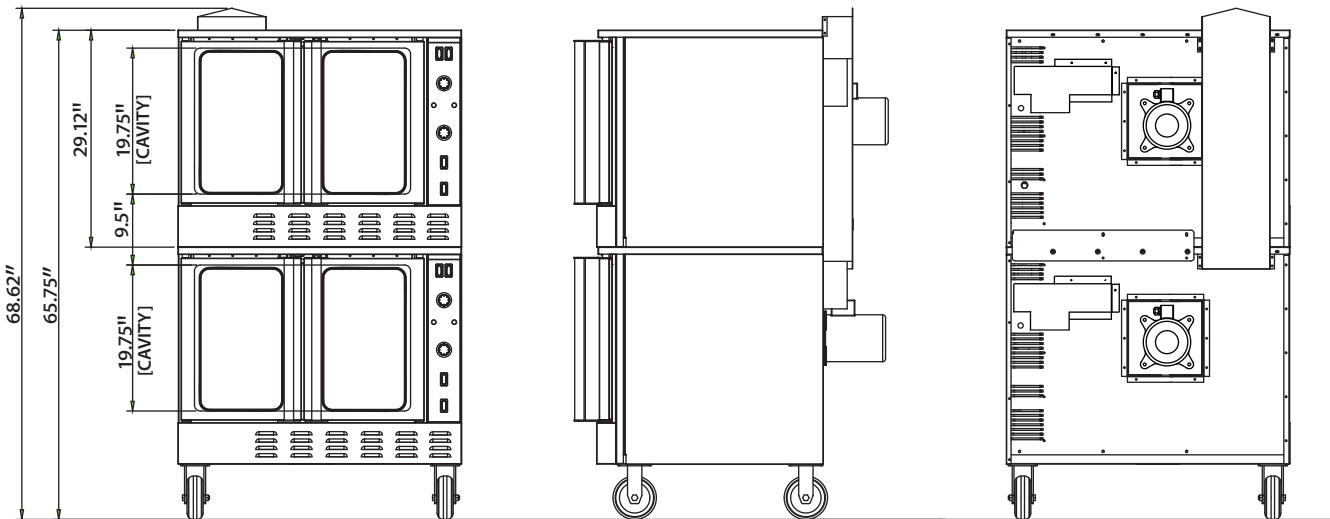

Dual Oven Configuration with Stacking Kit



| Model         | Overall Dimensions  | Oven Interior   | Rack Clearance                         | Shipping Crate(s)   |
|---------------|---|---|--|---|
| <b>SINGLE</b> | 38.12" W x 42.0" D x 60" H<br>(97 cm x 113 cm x 152 cm)   | 29" W x 22.5" D x 19.37" H<br>(74 cm x 57 cm x 50 cm) | 28" Width, 21" Depth<br>(72 cm, 54 cm) | 45.3" W x 49.2" D x 37" H, 48 cu ft., 481 lbs.<br>(115 cm x 125 cm x 99 cm, 1.35 cu m., 129 kgs.) |
| <b>DUAL</b>   | 38.12" W x 42.0" D x 65.62" H<br>(97 cm x 113 cm x 74 cm) | 29" W x 22.5" D x 19.37" H<br>(74 cm x 57 cm x 50 cm) | 28" Width, 21" Depth<br>(72 cm, 54 cm) | 2 Single Oven Crates, Total, 96 cu ft., 964 lbs.<br>(2.7 cu m., 258 kgs.)                         |

Order Oven Body quantity and leg configuration as desired:  
 TR-COE - Electric Convection Oven only  
 TR-CO-LK - Single Oven Leg Kit (Casters and Feet included) CP-  
 TR-CO-SK - Dual Oven Stacking Kit (HD Casters, Flue, Hardware)

Rev 1

| LEG OR STACKING KITS                      | Shipping Carton   |
|---|---|
| <b>SINGLE OVEN<br/>LEG AND CASTER KIT</b> | 29.9" L x 18.1" W x 8.7" H, 2.7 cu ft., 41 lbs.<br>(76 cm x 46 cm x 22 cm, 0.07 cu m., 18.5 kgs.) |
| <b>DUAL OVEN<br/>STACKING KIT</b>         | 38.2" L x 11.8" W x 6.7" H, 1.7 cu ft., 35 lbs.<br>(97 cm x 30 cm x 17 cm, 0.04 cu m., 16 kgs.)   |