

Pre Table With Sneeze Glass Refrigerator With Drawers

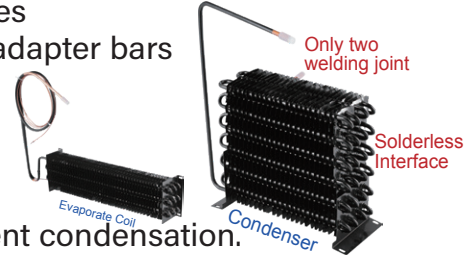

Features

- CFC free refrigerant and foam
- Built-in 19" high sneeze guard constructed from tempered glass on 3 sides
- Stainless steel frame and flat top Comes with 1/6 size 4" deep pans and adapter bars
- Unit can accommodate pans that are 6" deep
- Drawers are designed to fit a standard full size 1/1 pan.
- External construction comprises stainless steel framework.
- Internally constructed with 304 stainless steel.
- Incorporates auto defrosting and auto evaporation mechanisms to prevent condensation.
- The coated copper tube, boasting a sturdy 0.7mm thickness, ensures durability.
- Crafted from a single bent tube, minimizing the risk of leaks with only two welding joints.
- The condenser is efficiently positioned inside the condensation pan to facilitate the evaporation of excess water.
- Adjustable and heavy-duty epoxy-coated wire shelves for flexible storage options.
- Includes 1/6 size polycarbonate GN pans and a plastic cutting board.
- Comes with easy-to-mount 4" casters (front casters equipped with brakes), standard with all units.
- Electrical specifications: 115/60/1 with a NEMA 5-15P plug and a 10ft cord.



Temperature

- Interior temperature range: 1°C to 4°C (33°F to 40°F)

Warranty

- 3 years parts and labour
- 5 years compressor warranty



CSSU-S60MG-2D
CSSU-S72MG-2D



CSSU-S60MG-4D
CSSU-S72MG-4D



CSSU-S84MG-2D
CSSU-S96MG-2D



CSSU-S84MG-4D
CSSU-S96MG-4D



CSSU-S84MG-6D
CSSU-S96MG-6D

Specifications

Model	Doors & Drawers	1/6 Size	Ext. Dimensions W x D x H (in)	Storage Capacity(cu-ft)	V/Hz/Ph	AMPS	Power	NEMA PLUG	Ship Weight(lbs)	Ship Data W x D x H (in)
CSSU-S60MG-2D	1 & 2	24	60 x 34 1/2 x 35 5/8 (54 5/8)	15.65	115/60/1	4.5	400W/0.54HP	5-15P	507	35 5/8 x 63 1/2 x 58
CSSU-S60MG-4D	0 & 4	24	60 x 34 1/2 x 35 5/8 (54 5/8)	15.65	115/60/1	5	400W/0.54HP	5-15P	540	35 5/8 x 63 1/2 x 58
CSSU-S72MG-2D	1 & 2	30	72 x 34 1/2 x 35 5/8 (54 5/8)	20.12	115/60/1	5	450W/0.61HP	5-15P	607	35 5/8 x 75 1/2 x 58
CSSU-S72MG-4D	0 & 4	30	72 x 34 1/2 x 35 5/8 (54 5/8)	20.12	115/60/1	5	450W/0.61HP	5-15P	640	35 5/8 x 75 1/2 x 58
CSSU-S84MG-2D	2 & 2	36	84 x 34 1/2 x 35 5/8 (54 5/8)	25.49	115/60/1	5	450W/0.61HP	5-15P	706	35 5/8 x 75 1/2 x 58
CSSU-S84MG-4D	1 & 4	36	84 x 34 1/2 x 35 5/8 (54 5/8)	25.49	115/60/1	5	450W/0.61HP	5-15P	739	35 5/8 x 87 1/2 x 58
CSSU-S84MG-6D	0 & 6	36	84 x 34 1/2 x 35 5/8 (54 5/8)	25.49	115/60/1	5	450W/0.61HP	5-15P	772	35 5/8 x 87 1/2 x 58
CSSU-S96MG-2D	2 & 2	42	96 x 34 1/2 x 35 5/8 (54 5/8)	30.34	115/60/1	5.5	500W/0.67HP	5-15P	772	35 5/8 x 87 1/2 x 58
CSSU-S96MG-4D	1 & 4	42	96 x 34 1/2 x 35 5/8 (54 5/8)	30.34	115/60/1	5.5	500W/0.67HP	5-15P	805	35 5/8 x 99 3/8 x 58
CSSU-S96MG-6D	0 & 6	42	96 x 34 1/2 x 35 5/8 (54 5/8)	30.34	115/60/1	5.5	500W/0.67HP	5-15P	838	35 5/8 x 99 3/8 x 58



If the data and structure update, without notice, subject to material object.

Pre Table With Sneeze Glass Refrigerator With Drawers



CSSU-S60MG-2D
CSSU-S72MG-2D

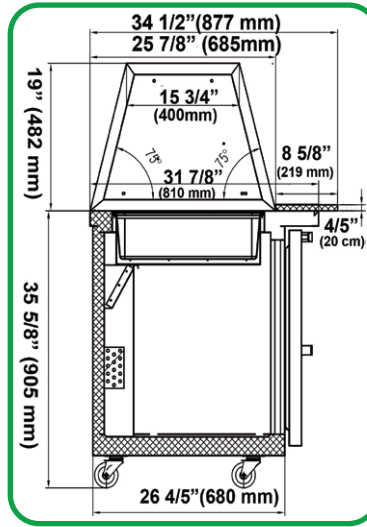
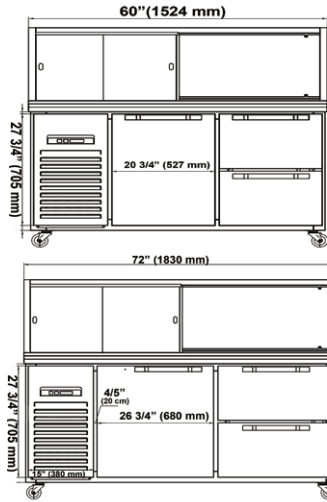

CSSU-S60MG-4D
CSSU-S72MG-4D

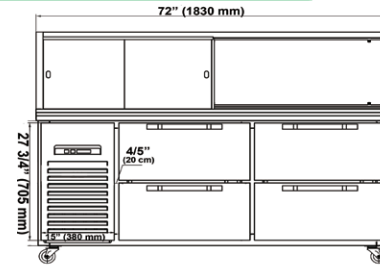
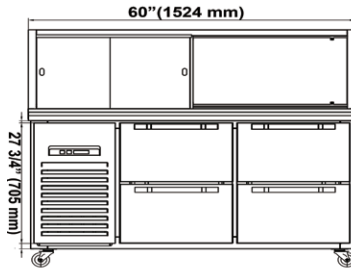

CSSU-S84MG-2D
CSSU-S96MG-2D

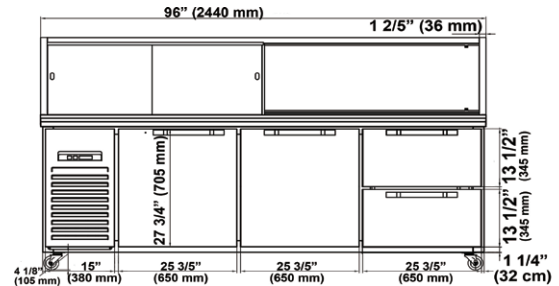
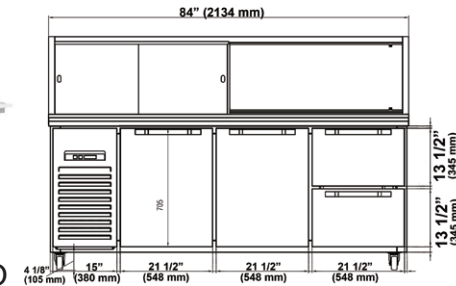

CSSU-S84MG-4D
CSSU-S96MG-4D

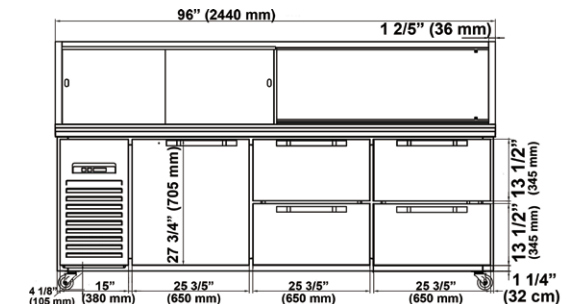
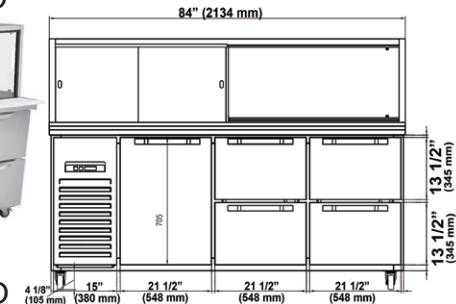

CSSU-S84MG-6D
CSSU-S96MG-6D

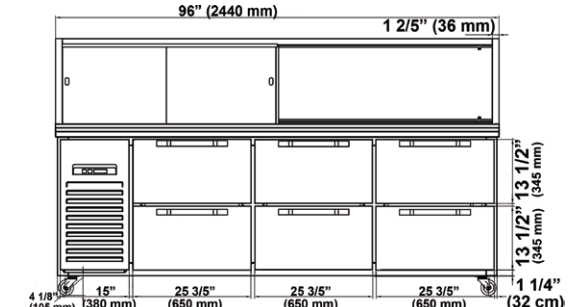
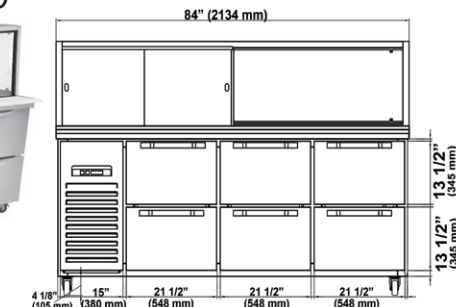

If the data and structure update, without notice, subject to material object.