



Project \_\_\_\_\_  
 Item # \_\_\_\_\_  
 Quantity \_\_\_\_\_

# SPECTRUM

## Electric Countertop Griddles

Models: EGD-24M | EGD-36M

The SPECTRUM ELECTRIC GRIDDLES have a wide heat range to cook eggs on low heat and burgers on high heat on the half-inch thick polished steel grill surface. The independent controlled heat zones even allow for more versatility. Minimize grease splatters with an extra-tall steel wall enclosure and backsplash.

### Standard Features

- ◆ Solid 1/2" thick polished steel plate for fast heat up and high heat retention
- ◆ Heavy gauge stainless steel body, and sloped side & 3" backsplash
- ◆ Large volume removable grease drawer with weep hole and baffle
- ◆ Heavy duty, stainless steel adjustable legs for stability
- ◆ Compatible for 1-phase or 3-phase operation (field convertible)
- ◆ 3-1/4" full width grease trough
- ◆ EGD-24M: Two (2) thermostatically controlled heat zones
- ◆ EGD-36M: Three (3) thermostatically controlled heat zones
- ◆ One year parts and labor warranty



EGD-24M



EGD-36M



EGD-SERIES

### Parts

EGD-MP1	Leg
EGD-MP3	Drip Tray
EGD-MP6	Knob
EGD-MP15-24	Plug & Lead for EGD-24M

### Accessories

SCRP-14	16" Heavy-duty Aluminum Grill Scraper
SCRP-16	16" Aluminum Grill Scraper
SCRP-12	12" Aluminum Grill Scraper
GSH-1	Griddle Screen Holder
GSN-4	Grill Screen, fits with GSH-1
GBH-2	Griddle Brick Holder
GBK-348	Grill Brick, fits with GBH-2

**For California Customers**  
 ⚠ **WARNING:** Cancer and Reproductive Harm - [www.P65Warnings.ca.gov](http://www.P65Warnings.ca.gov)

Winco®, DWL International Trading, LLC

[www.wincous.com](http://www.wincous.com) | [equipsales@wincous.com](mailto:equipsales@wincous.com)

**New Jersey Headquarters:**  
 65 Industrial Road, Lodi, NJ 07644  
 Tel. 1.888.946.2682 | Fax: 1.888.946.2632

**California Distribution Center**  
 14950-14952 Valley View Avenue, La Mirada, CA 90638  
 Tel. 1.888.946.2652 | Fax: 1.562.926.5678

**Florida Distribution Center**  
 10800 NW 103rd St. Bldg 22, Ste 11, Miami, FL 33178  
 Tel. 1.786.536.4656



## Electric Countertop Griddles

Models: EGD-24M | EGD-36M

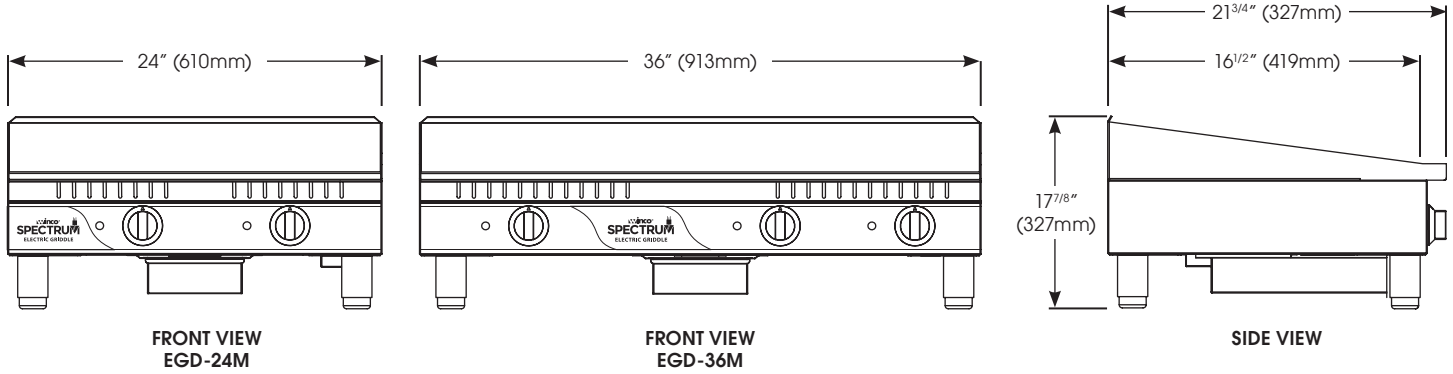

MODEL	DESCRIPTION	OVERALL DIMENSIONS			VOLTS	HZ	WATTS	AMPS	PLUG	SHIP WEIGHT
		LENGTH	DEPTH	HEIGHT						
EGD-24M	24" Griddle with Plug	24" (610mm)	21-3/4" (551mm)	12-7/8" (327mm)	208/240V	50/60 Hz	4200/5600W	20.2/23.4A 1-phase	NEMA L6-30P	116.84 lbs (53 kg)
EGD-36M	36" Griddle	36" (913mm)	21-3/4" (551mm)	12-7/8" (327mm)			6300/8400W	30.29/35A 1-phase	Field-wired by others	159.61 lbs (72.4 kg)

Note: Cooking surface depth 16-1/2"(419mm)

### Cord Location (EGD-24M)

Right side rear of unit

### Terminal Block Location (EDG-36M)

Access through right side rear of unit

### Plug Configuration (EGD-24M)

NEMA L6-30P

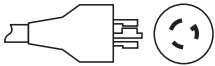

### Product Specs

#### Electric Countertop Griddles

The Electric Countertop Griddles models EGD-24M and EGD-36M as manufactured by Winco®, Lodi, NJ 07644.

The Electric Countertop Griddle EGD-24M shall be rated at 4200/5600 Watts, 208/240V~60Hz/1 and supplied with a NEMA L6-30P plug and the Electric Countertop Griddle EGD-36M shall be rated at 6300/8400 Watts, 208/240V~60Hz/1 and must be field-wired. Units shall be equipped with solid 1/2" thick polished steel plate, stainless steel body, 3" backsplash and large volume removable grease drawer with weep hole and baffle, 3-1/4" full width grease trough, heavy-duty adjustable legs for stability, and be compatible for 1-phase or 3-phase operation. EGD-24M has two (2) thermostatically controlled heat zones while EGD-36M has three (3) thermostatically controlled heat zones.

Warranty consists of one year parts and labor.

Winco®, DWL International Trading, LLC

New Jersey Headquarters:  
65 Industrial Road, Lodi, NJ 07644  
Tel. 1.888.946.2682 | Fax: 1.888.946.2632

California Distribution Center  
14950-14952 Valley View Avenue, La Mirada, CA 90638  
Tel. 1.888.946.2652 | Fax: 1.562.926.5678

Florida Distribution Center  
10800 NW 103rd St. Bldg 22, Ste 11, Miami, FL 33178  
Tel. 1.786.536.4656

www.wincous.com | equipsales@wincous.com