

Chef Base

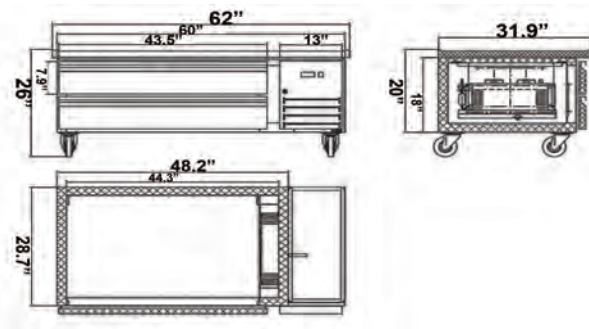

CFC free refrigerant and foam insulation
 Electronic thermostat and digital LED temperature display for accurate control and easy reading
 Magnetic gasket can be replaced without any tools
 External: Stainless steel framework construction
 Internal: S/S 304 & coated aluminum & ABS plastic
 Auto defrosting and auto evaporation to prevent condensation
 Condensation pan efficiently evaporates excess water
 Easy to mount 3" casters (front casters with brakes) are standard with all units
 Temperature: 33°F to 40°F / 1°C to 4°C
 Electrical: 115/60/1 with NEMA 5-15P plug, 10ft cord

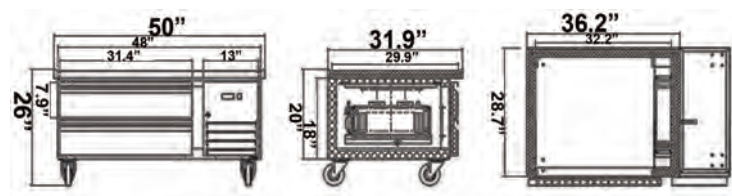

SPECIFICATIONS

Refrigerator

Model	Drawers	Ext. Dimensions W x D x H (in)	Int.. Dimensions W x D x H (in)	V/Hz/Ph	AMPS	HP	Storage Capacity(cu-ft)	NEMA PLUG	Ship Weight(lbs)	Ship Data W x D x H (in)
CCB-36	2	38x31.9x26		115/60/1	1.5A	1/3		5-15P	205	
CCB-48	2	50x31.9x26		115/60/1	2.1A	1/3		5-15P	260	51.2x32.9x27.8
CCB-60	2	62x31.9x26		115/60/1	2.1A	1/3		5-15P	302	63.2x32.9x27.8



Certified To ANSI/NSF 7 Standards
 If the data and structure update, without notice, subject to material object

