

❖ Chest Freezer



Features

- Flat Glass Lid
- 60mm Insulation.
- A+ Level Power Consumption, Save Energy.
- Temperature Display.
- Drainage Is On Front, Easy To Collect Water.
- Stealthily Handle, Strong And Not Easy To Broken In Kitchen.
- Internal Round Edges, Easy To Clean.
- Quickly And Deeply Freezing.
- Low Noise Design.
- Temperature: -18 ~ -25°C



CF-30FG CF-38FG



CF-47FG CF-55FG CF-72FG CF-79FG

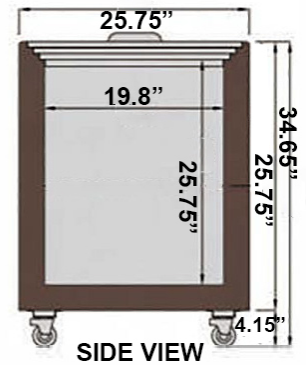
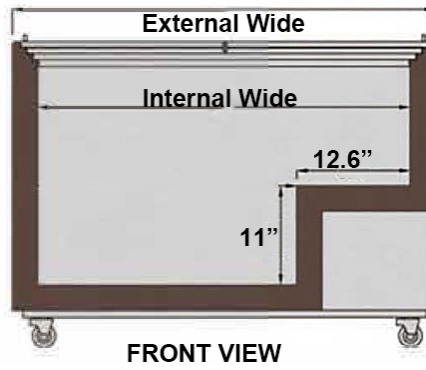
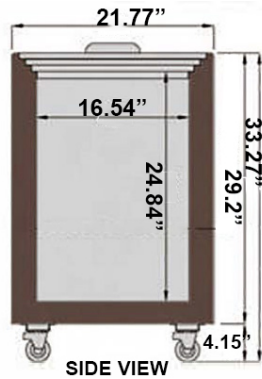
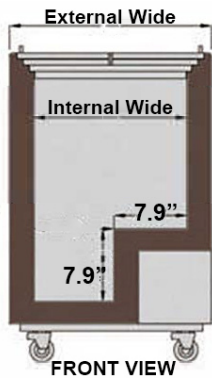

Specifications

MODEL	Ext. Dimensions W X D X H (In)	Int.. Dimensions W X D X H (In)	CAPACITY L/Sq-ft	V/Hz/Ph	BASKET	NET WEIGHT LBS	GROSS WEIGHT LBS	NEMA PLUG
CF-30FG	30x22x33	24.41X16.54X24.84	148 / 5.3	115V/60HZ/1	1 big+1 small	80	95	5-15P
CF-38FG	38x22x33	32.28X16.54X24.84	201 / 7.1	115V/60HZ/1	1 big+2 small	93	110	5-15P
CF-47FG	47x26x35	41.3X19.84X25.75	298 / 10.6	115V/60HZ/1	3 big	133	155	5-15P
CF-55FG	55x26x35	49.17X19.84X25.75	332 / 14.1	115V/60HZ/1	3 big+1 small	148	174	5-15P
CF-71FG	70.75x26x35	64.92X19.84X25.75	400 / 17.7	115V/60HZ/1	2 big+4 small	166	212	5-15P
CF-79FG	78.7x26x35	72.8X19.84X25.75	513 / 21.2	115V/60HZ/1	4 big+2 small	192	232	5-15P



Certified To ANSI/NSF 7 Standards

If the data and structure update, without notice, subject to material object.