



Model: CHD-36

## STANDARD FEATURES

- Toughened glass all sides
- Thermostat controlled, durable and robust
- Temperature display to monitor inside temperature
- Temperature range 30~90°C
- Cool to touch plastic handle
- Water reservoir at the bottom to add humidity when needed
- Extra deep reservoir GN1/9 x 2.5" to last for whole day
- Three levels of shelves inside chamber
- Shelf height can be adjusted
- Rubber seal between door and frame to prevent heat loss
- Vertical fluorescent lamp on both sides for better food display
- Transparent cover on fluorescent lamps

## Plan View

CHD-26

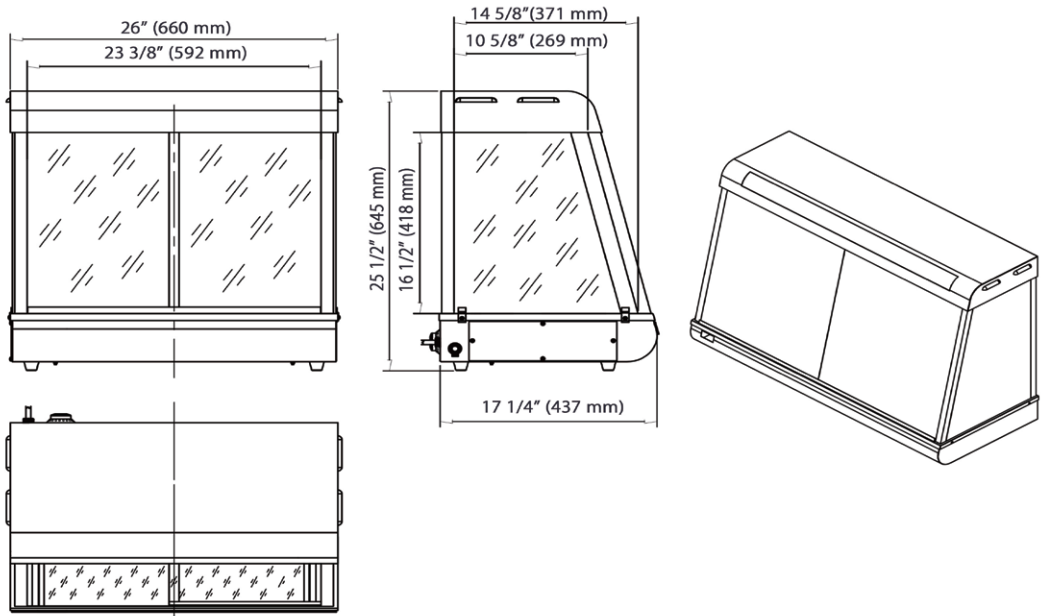

# Electric food warmer showcase



## Plan View

CHD-36

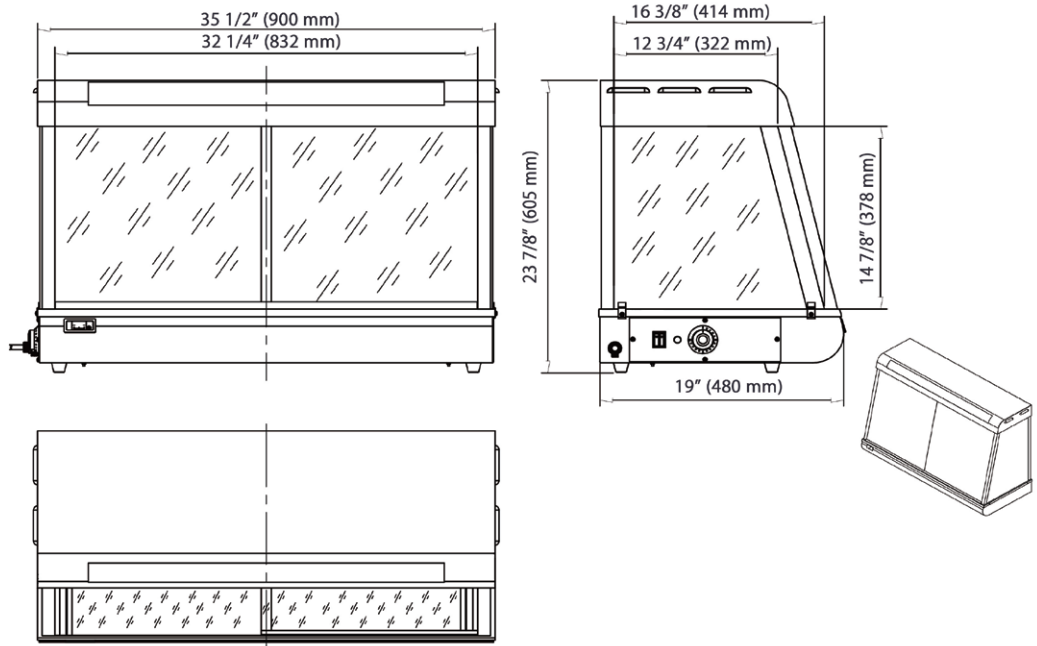

CHD-48

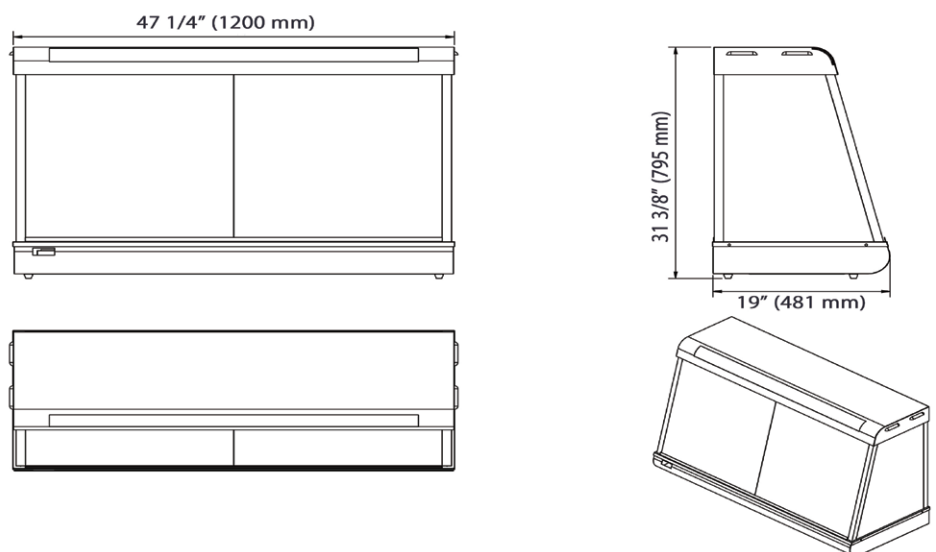

Model	Power	V/Hz/Ph	Shelfsize	Packingsize	N/W	G/W
CHD-26	1600W	120V 60Hz 1Ph	580 x 275 mm / 23 x 11 inch 580 x 298 mm / 23 x 12 inch 580 x 318 mm / 23 x 13 inch	730X480X670 mm 28 3/4 x 19 x 26 3/8"	35KG 77.2 lbs	39KG 86 lbs
CHD-36	1500W		820 x 315 mm / 32 x 12 inch 820 x 340 mm / 32 x 13 inch 820 x 360 mm / 32 x 14 inch	990X600X750 mm 35 1/2 x 23 5/8 x 29 1/2"	50KG 110.3 lbs	54KG 119 lbs
CHD-48	1500W		1120 x 315 mm / 44 x 12 inch 1120 x 340 mm / 44 x 13 inch 1120 x 360 mm / 44 x 14 inch	1260X600X890 mm 49 5/8 x 23 5/8 x 35"	72KG 158.8 lbs	74KG 163.2 lbs

