

EN

**MG2**

**PACKAGING DIVISION**

**BliStar**



**MG2** ®  
*Keeping ahead for you*

## BliStar

### Intermittent-motion blistering machine

The BliStar blistering machine has been designed to ease and optimize the production process.

BliStar main features are:

- touch-screen panel to allow the visualization of machine status in real time;
- motorized reel unwinder (forming and sealing) with centring adjustment;
- forming, cutting and pre-cutting operations equipped with servo motors and quick release locking mechanism;
- control of forming/lidding reels junction with automatic feeding switch off;
- system to detect the presence of any product outside the cavity before sealing;
- continuous sealing system equipped with servo motors and speed, temperature and pressure adjustments;
- easy and quick size changeover with minimum adjustments.

#### Technical Data

- Packaging materials: PVC/ALU, PVC-PVDC/ALU, PVC-PE-PVDC/ALU, PVC-ACLAR/ALU, PET/ALU, ALU/ALU
- Blister dimensions: max 90x140 mm
- Speed: up to 150 blisters per minute
- Max forming width: 170 mm
- Min-Max width of forming foil: 80-170 mm
- Max forming depth: 12 mm
- Max cutting pitch: 90 mm
- Reel of forming foil: max Ø 500 mm
- Reel of lidding material: max Ø 300 mm
- Reels inner core diameter: 70-76 mm
- Mains power: 400V (±10%) three-phase 50Hz or 480V (±10%) three-phase 60Hz
- Installed power: 12 kW
- Compressed air consumption: 250 NI/min
- Compressed air pressure: 400-800 kPa

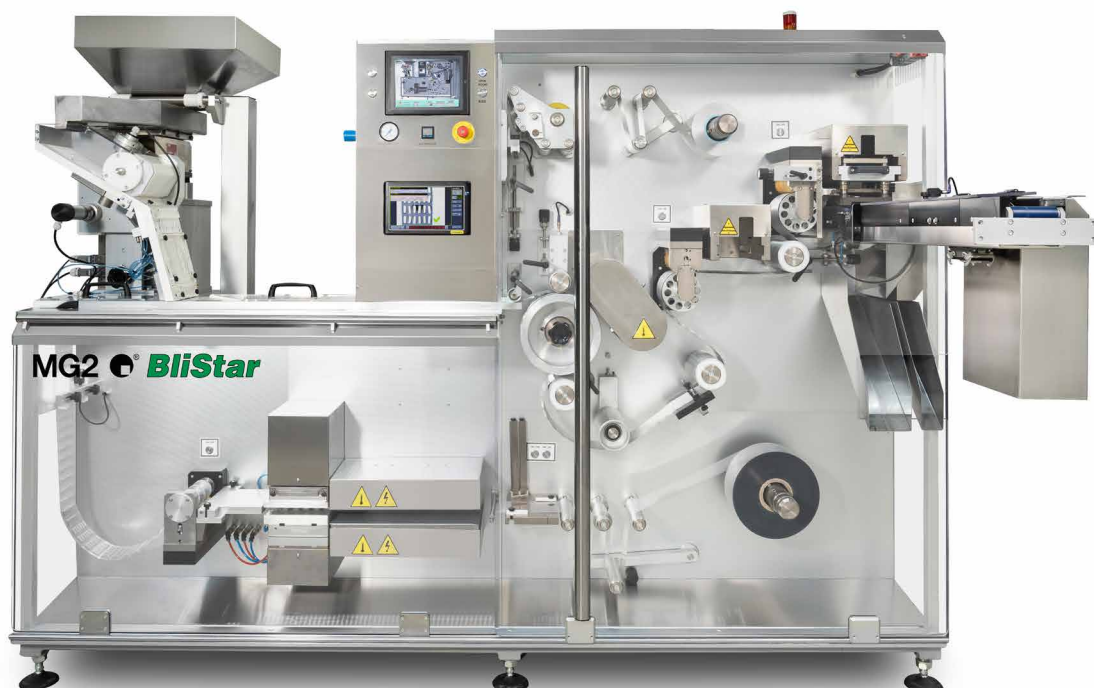

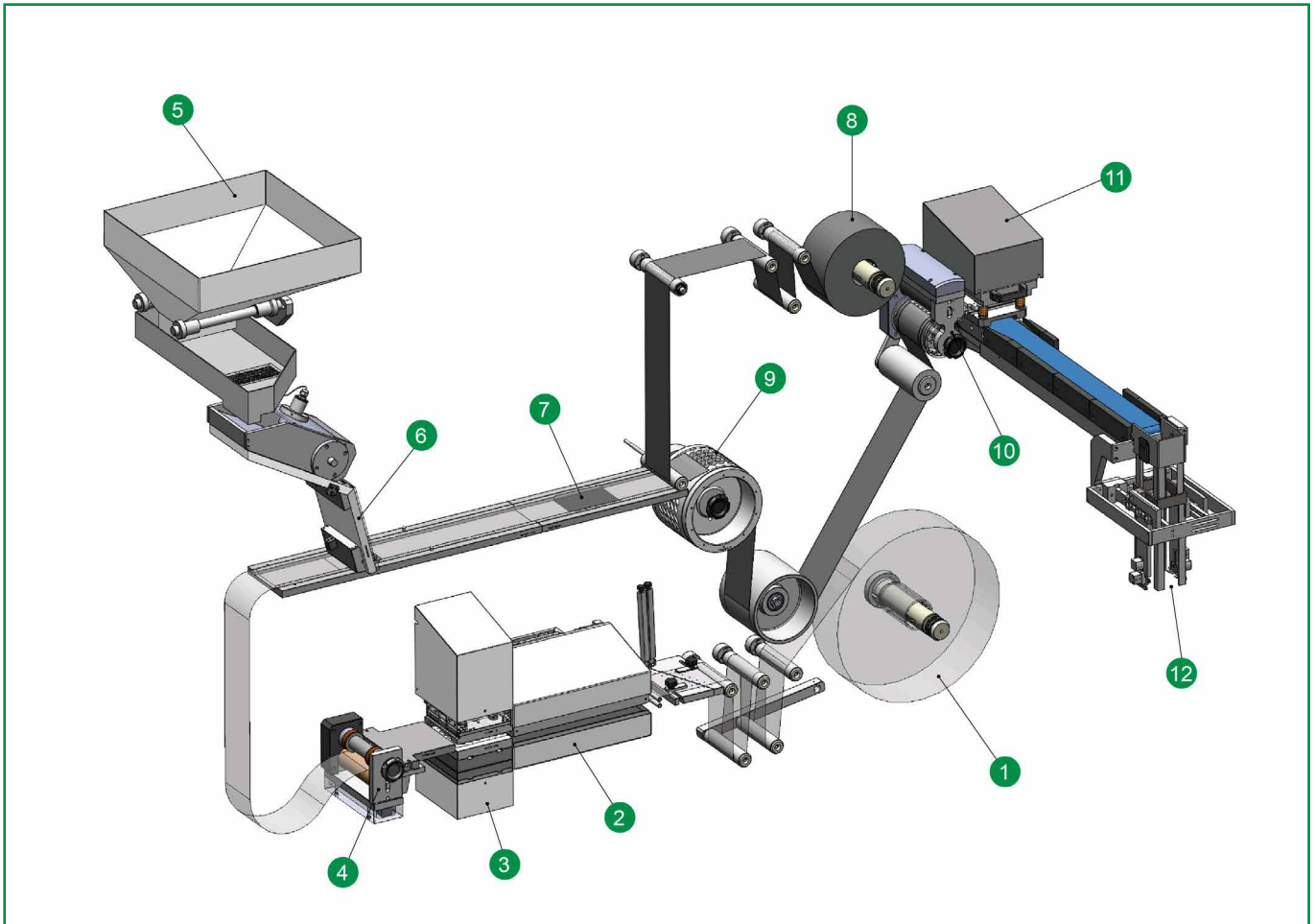

- |                                            |                                 |
|--------------------------------------------|---------------------------------|
| 1. Forming material reel                   | 7. Area for vision system       |
| 2. Pre-heating unit for thermoforming foil | 8. Lidding material reel        |
| 3. Forming unit                            | 9. Sealing drum                 |
| 4. Forming material dragging rollers       | 10. Foil dragging rollers       |
| 5. Pre-feeding hopper                      | 11. Blister cutting unit        |
| 6. Dedicated feeding unit                  | 12. Blister magazine (optional) |

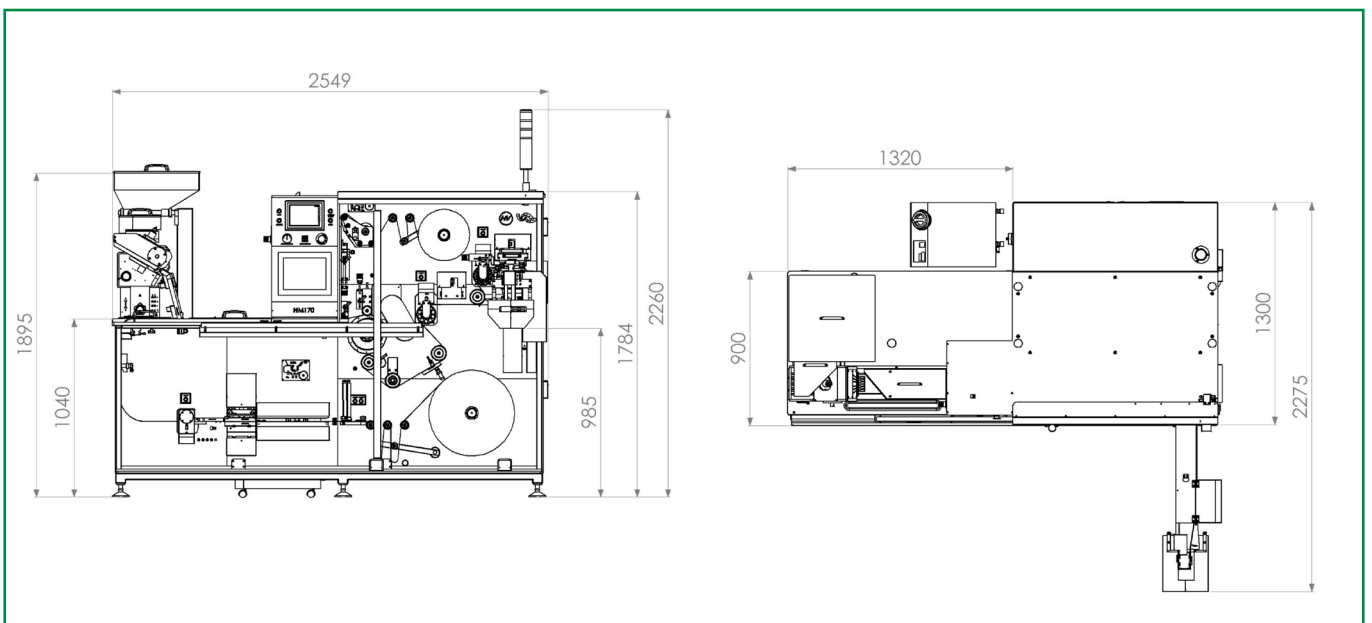



**MG2** ®

MG2

Via del Savena 18

40065 Pian di Macina di Pianoro, Bologna - Italy

Tel. +39 051 4694111 - Fax +39 051 4694199

[www.mg2.it](http://www.mg2.it) - [sales@mg2.it](mailto:sales@mg2.it)

**MG AMERICA** 

MG AMERICA

31 Kulick Road

07004 Fairfield N.J. - USA

Tel. +1 973 8088185 - Fax +1 973 8088421

[www.mgamerica.com](http://www.mgamerica.com) - [sales@mgamerica.com](mailto:sales@mgamerica.com)

The present material serves by way of example only and is not binding.  
Given the constant technical developments on machines, as well as customer requirements, the specifications applicable are those agreed with the purchaser.