



# USBC-FS-RS232-0V-1800-WE

## Datasheet

Document Reference No.: CP\_000064

Version 1.3

**Connective Peripherals Pte Ltd**  
**178 Paya Lebar Road, #07-03 Singapore 409030**  
**Tel.: +65 67430980 Fax: +65 68416071**

E-Mail (Support): [support@connectiveperipherals.com](mailto:support@connectiveperipherals.com) Web: [www.connectiveperipherals.com/products](http://www.connectiveperipherals.com/products)

Neither the whole nor any part of the information contained in, or the product described in this manual, may be adapted or reproduced in any material or electronic form without the prior written consent of the copyright holder. This product and its documentation are supplied on an as-is basis and no warranty as to their suitability for any particular purpose is either made or implied. Connective Peripherals Pte Ltd will not accept any claim for damages howsoever arising as a result of use or failure of this product. Your statutory rights are not affected. This product or any variant of it is not intended for use in any medical appliance, device or system in which the failure of the product might reasonably be expected to result in personal injury. This document provides preliminary information that may be subject to change without notice. No freedom to use patents or other intellectual property rights is implied by the publication of this document. Connective Peripherals Pte Ltd, 178 Paya Lebar Road, #07-03 Singapore 409030. Registered Number: 201617872E

Copyright © Connective Peripherals Pte Ltd

## 1 Introduction

The **USBC-FS-RS232-0V-1800-WE** is a USB Type C to RS232-level serial UART converter cable incorporating FTDI's FT230XQ USB to serial UART interface IC device which handles all the USB signalling and protocols. The cable provides a fast, simple way to connect devices with a RS232 level serial interface to USB Type C.

The USBC-FS-RS232-0V-1800-WE contains a small internal electronic circuit board, utilising the [FT230X](#), which is encapsulated into the USB Type C connector end of the cable. Refer to the [FT230X datasheet](#) for details. The integrated electronics also include the RS232 level shifter.

The other end of the cable has bared, tinned wire ended connections by default, allowing a variety of connectors to be attached. The cables can be customised using different connectors to support various applications. Please contact Connective Peripherals Sales ([sales@connectiveperipherals.com](mailto:sales@connectiveperipherals.com)) for more information.

The cable is FCC, CE, UKCA and RoHS compliant.

The USB Type C side of the cable is USB powered and USB 2.0 full speed compatible. Each cable is 1.8m long and supports a data transfer rate up to 1 MBaud. Each cable supports the FTDIChip-ID™, with a unique USB serial number programmed into the FT230X. This feature can be used to create a security or password protected file transfer access using the cable (requires D2XX drivers). Further information and examples on this feature are available at [FTDIChip-ID Projects](#).

The USBC-FS-RS232-0V-1800-WE requires USB drivers, available free from <http://www.connectiveperipherals.com>, which are used to make the FT230X in the cable appear as a virtual COM port (VCP). This allows the user to communicate with the USB Type C interface via a standard PC serial emulation port (for example TTY). Another USB driver, the D2XX driver, can also be used with application software to directly access the FT230X on the cable through a DLL. This is illustrated in Figure 1.1.

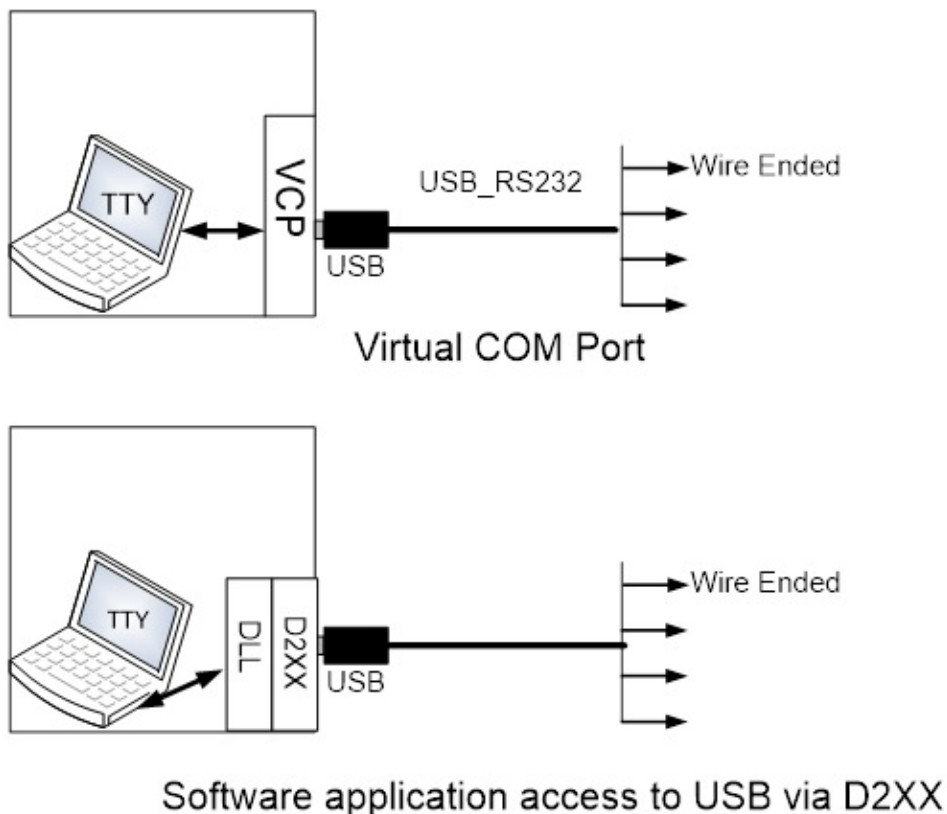

**Figure 1.1 Using the USBC-FS-RS232-0V-1800-WE**

## 1.1 Part Numbers

Table 1.1 gives details of the USBC-FS-RS232-0V-1800-WE part numbers.

Part Number	Description	End Connector*	Cable details
USBC-FS-RS232-0V-1800-WE	USB Type C Full Speed to RS232 cable with red wire at 0V (open)	Wire Ended (no connector)	1.8m cable, 6 core, UL2464 26 AWG, diam=4.8mm, Black

**Table 1.1 USBC-FS-RS232-0V-1800-WE Descriptions and Part Numbers**

CP supports customisation such as end connectors, 5V or 3.3V on red wire, and transparent housing with Tx/Rx LEDs. For more information, please contact your local CP sales office (see section 6 for contact details).

The output voltage on the red wire is set during manufacture and the PCB is not accessible once the connector has been moulded.

## 1.2 Certifications

USBC-FS-RS232-0V-1800-WE is fully RoHS compliant as well as CE, FCC and UKCA certified.



## **Table of Contents**

<b>1</b>	<b>Introduction .....</b>	<b>1</b>
1.1	Part Numbers.....	2
1.2	Certifications .....	2
<b>2</b>	<b>Typical Applications .....</b>	<b>4</b>
2.1	Driver Support .....	4
2.2	Driver Installation.....	4
2.3	Features.....	5
<b>3</b>	<b>FT230X features relevant to USBC-FS-RS232-0V-1800-WE</b>	<b>6</b>
<b>4</b>	<b>USBC-FS-RS232-0V-1800-WE.....</b>	<b>7</b>
4.1	USBC-FS-RS232-0V-1800-WE Connections & Mechanical Details	7
4.2	USBC-FS-RS232-0V-1800-WE Signal Descriptions .....	7
4.3	USBC-FS-RS232-0V-1800-WE Electrical Parameters .....	8
<b>5</b>	<b>Cable PCB Circuit Schematic.....</b>	<b>9</b>
<b>6</b>	<b>Contact Information.....</b>	<b>10</b>
<b>Appendix A - Cable MTP Configuration .....</b>		<b>11</b>
<b>Appendix B - List of Figures and Tables .....</b>		<b>12</b>
List of Figures .....		12
List of Tables.....		12
<b>Appendix C - Revision History .....</b>		<b>13</b>

## 2 Typical Applications

- USB to serial RS232 level converter.
- Upgrading legacy peripherals to USB.
- Interface Microcontroller UART or I/O to USB\*
- Interface FPGA or PLD to USB\*
- USB Instrumentation PC interface.
- USB industrial control.
- USB password protected file transfers.

**Note:** This cable uses RS232 levels and so an RS232 level shifter would be required at the MCU/FPGA/CPLD side as most MCUs/FPGAs/CPLDs use TTL/CMOS levels.

### 2.1 Driver Support

#### Royalty free VIRTUAL COM PORT (VCP) DRIVERS for...

- Windows 11, 10, 8.x, 7
- Windows XP (legacy)
- Windows CE 4.2, 5.0 and 6.0 (Legacy)
- macOS 10.9 and above
- Linux 2.4 and greater

#### Royalty free D2XX Direct Drivers (USB Drivers + DLL S/W Interface)

- Windows 11, 10, 8.x, 7
- Windows XP (legacy)
- Windows CE 4.2, 5.0 and 6.0 (Legacy)
- macOS 10.9 and above
- Linux 2.4 and greater

The drivers listed above are all available to download for free from <https://connectiveperipherals.com> Various legacy and 3rd Party Drivers are also available for other operating systems. Refer to <https://connectiveperipherals.com> and [www.ftdichip.com](http://www.ftdichip.com) for details.

### 2.2 Driver Installation

For driver installation, please refer to the **Connective Peripherals USB to Serial Converters Driver Installation Guide (CP\_000084)** which is available from [www.connectiveperipherals.com](http://www.connectiveperipherals.com).

## 2.3 Features

- USBC-FS-RS232-0V-1800-WE converter provides a USB Type C to RS232 serial interface with customised end connectors.
- Entire USB protocol handled by the electronics in the cable's USBC moulding.
- EIA/TIA-232 and V.28/V.24 communication interface with low power requirements.
- UART interface support for 7 or 8 data bits, 1 or 2 stop bits and odd / even / mark / space / no parity.
- Internal MTP memory with user writeable area.
- FTDI's royalty-free VCP drivers allow for communication as a standard emulated COM port and D2XX 'direct' drivers provide DLL application programming interface.
- Fully assisted hardware (RTS#/CTS#) or X-On / X-Off software handshaking.
- Data transfer rates from 300 baud to 1 Mbaud.
- Support for FT230X FTDIChip-ID™ feature for improved security.
- Low USB bandwidth consumption.
- UHCI / OHCI / EHCI host controller compatible.
- USB 2.0 Full Speed compatible.
- -40°C to +85°C operating temperature range.
- Cable length is 1.80m (6 feet).
- ESD Protection for RS-232 I/O's  
±15kV Human Body Model (HBM)  
±15kV EN61000-4-2 Air Gap Discharge  
±8kV EN61000-4-2 Contact Discharge
- FCC, CE and UKCA compliant.
- Custom versions available on request (subject to MOQ).

### 3 FT230X features relevant to USBC-FS-RS232-0V-1800-WE

The USBC-FS-RS232-0V-1800-WE uses the FT230XQ USB to serial UART IC device. This section summarises the key features of the FT230XQ which apply to the USBC-FS-RS232-0V-1800-WE USBC to serial RS232 converter. For further details, and a full features and enhancements description, refer to the [FT230X](#) datasheet.

**Internal MTP memory (Multi-Time Programmable).** The internal MTP in each cable operates in the same way as an EEPROM and is used to store USB Vendor ID (VID), Product ID (PID), device serial number, product description string and various other USB configuration descriptors. Each cable is supplied with the internal MTP pre-programmed as described in Appendix A - Cable MTP Configuration. The internal MTP descriptors can be programmed in circuit, over USB without any additional voltage requirement. It can be programmed using the FTDI utility software called [FT\\_Prog](#), which can be downloaded from <https://www.ftdichip.com/Support/Utilities.htm>. Additionally, there is a user area of the internal MTP available to system designers to allow storing of data (note that this is not modified by FT\_Prog).

**Lower Operating and Suspend Current.** The FT230X has a low 8mA operating supply current and a very low USB suspend current of approximately 125µA. (Note that during suspend mode, the current drawn by any customised cable application which uses the USB supply, should not exceed 2.5mA to remain USB compliant)

**Low USB Bandwidth Consumption.** The USB interface of the FT230X, and therefore the USBC-FS-RS232-0V-1800-WE has been designed to use as little as possible of the total USB bandwidth available from the USB host controller.

**UART Pin Signal Inversion.** The sense of each of the UART signals can be individually inverted by configuring options in the internal EEPROM. For example, CTS# (active low) can be changed to CTS (active high), or TXD can be changed to TXD#.

**FTDChip-ID™.** The FT230X includes the new FTDChip-ID™ security dongle feature. This FTDChip-ID™ feature allows a unique number to be burnt into each cable during manufacture. This number cannot be reprogrammed. This number is only readable over USB and can be used to form the basis of a security dongle for software licensing. Further to this, a renewable license scheme can be implemented based on the FTDChip-ID™ number when encrypted with other information. This encrypted number can be stored in the user area of the FT230X internal EEPROM, and can be decrypted, then compared with the protected FTDChip-ID™ to verify that a license is valid. For examples, please see [FTDChip-ID Projects](#).

**Improved EMI Performance.** The USBC-FS-RS232-0V-1800-WE is FCC, CE and UKCA certified.

**Extended Operating Temperature Range** - The USBC-FS-RS232-0V-1800-WE are capable of operating over an extended temperature range of -40° to +85° C thus allowing them to be used in automotive or industrial applications.

## 4 USBC-FS-RS232-0V-1800-WE

The USBC-FS-RS232-0V-1800-WE is un-terminated; it has bared and tinned wires.

### 4.1 USBC-FS-RS232-0V-1800-WE Connections & Mechanical Details

The following Figure 4.1 shows the cable signals and the wire colours for the signals on the USBC-FS-RS232-0V-1800-WE.

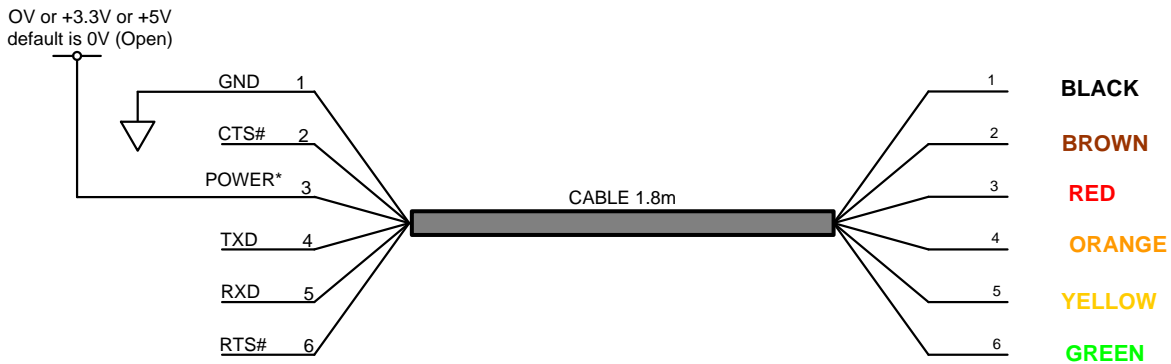

POWER\* - default is 0V (open) but can be manufactured to provide +3.3V or +5V

**Figure 4.1 USBC-FS-RS232-0V-1800-WE Connections**

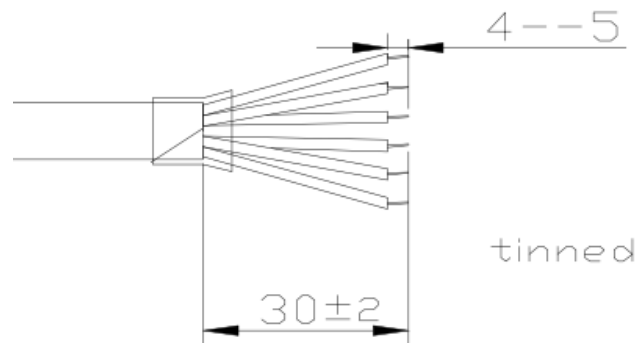

**Figure 4.2 USBC-FS-RS232-0V-1800-WE Mechanical Details (dimensions in mm)**

### 4.2 USBC-FS-RS232-0V-1800-WE Signal Descriptions

Colour	Name	Type	Description
Black	GND	GND	Device ground supply pin.
Brown	CTS#	Input	Clear to Send Control input / Handshake signal.
Red	POWER	Output	Power output. It can be customised to output +3.3V or +5V. Default version is 0V (open). If required, contact CP Sales <a href="mailto:sales@connectiveperipherals.com">sales@connectiveperipherals.com</a>
Orange	TXD	Output	Transmit Asynchronous Data output.
Yellow	RXD	Input	Receive Asynchronous Data input.
Green	RTS#	Output	Request To Send Control Output / Handshake signal.

**Table 4.1 USBC-FS-RS232-0V-1800-WE Signal Descriptions**



### 4.3 USBC-FS-RS232-0V-1800-WE Electrical Parameters

Parameter	Description	Minimum	Typical	Maximum	Units	Conditions
VCC_5V	Output Power Voltage*	4.25	5.0*	5.25	V	*Default is 0V (open). This figure only applies when cable has been customised to output +5V. The range is dependent on the USB Type-C port that the USBC-FS-RS232-0V-1800-WE is connected to
VCC_3.3V	Output Power Voltage**	3.2	3.3**	3.4	V	**Default is 0V (open). This figure only applies when cable has been customised to output +3.3V.
I <sub>o</sub>	Output Power Current***	-		75	mA	***Only applies when POWER output is customised to +5V or +3.3V. Must be less than 2.5mA during suspend.
T	Operating Temperature Range	-40		+85	°C	

**Table 4.2 USBC-FS-RS232-0V-1800-WE I/O Operating Parameters**

Parameter	Description	Minimum	Typical	Maximum	Units	Conditions
V <sub>trans</sub>	Transmitter output voltage swing	+/- 5	+/- 6.5	+/- 15	V	
V <sub>rec</sub>	Receiver input voltage range	-25		+25	V	

**Table 3.3 USBC-FS-RS232-0V-1800-WE I/O Pin Characteristics**

Description	Conditions	Minimum	Typical	Maximum
ESD HBM	RS-232 Inputs and Outputs		±15 kV	
EN61000-4-2ContactDischarge	RS-232 Inputs and Outputs		±8 kV	
EN61000-4-2AirGapDischarge	RS-232 Inputs and Outputs		±15 kV	

**Table 4.4 USBC-FS-RS232-0V-1800-WE ESD Tolerance**

## 5 Cable PCB Circuit Schematic

The circuit schematic for the small internal electronic circuit board, utilising the FT230X, which is encapsulated into the USBC connector end of the cable, is shown in Figure 5.1.

Customised versions of the cable are also available. Users interested in customised versions of these cables should contact [sales@connectiveperipherals.com](mailto:sales@connectiveperipherals.com).

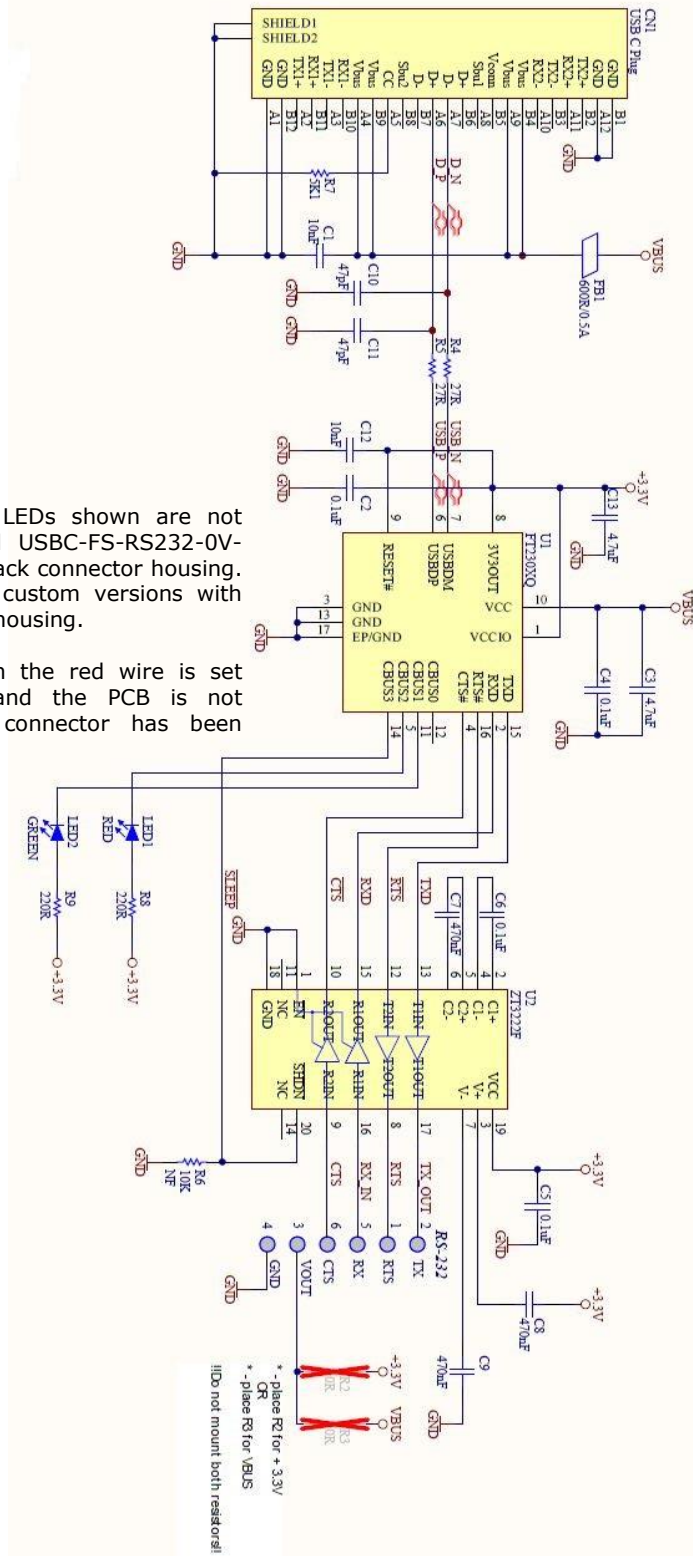

Note that the Tx/Rx LEDs shown are not fitted in the standard USBC-FS-RS232-0V-1800-WE as it has a black connector housing. They are available in custom versions with transparent connector housing.

The output voltage on the red wire is set during manufacture and the PCB is not accessible once the connector has been moulded.

**Figure 5.1 Circuit Schematic of PCB Used in the USBC to RS232 Serial Converter Cable**

## 6 Contact Information

### Global Headquarters – Singapore

Connective Peripherals Pte Ltd  
178 Paya Lebar Road  
#07-03  
Singapore 409030

Tel: +65 67430980  
Fax: +65 68416071

E-Mail (Sales)	<a href="mailto:sales@connectiveperipherals.com">sales@connectiveperipherals.com</a>
E-Mail (Support)	<a href="mailto:support@connectiveperipherals.com">support@connectiveperipherals.com</a>
Web Site URL	<a href="http://www.connectiveperipherals.com">http://www.connectiveperipherals.com</a>
Web Shop URL	<a href="http://www.connectiveperipherals.com">http://www.connectiveperipherals.com</a>

## Appendix A - Cable MTP Configuration

Each USBC-FS-RS232-0V-1800-WE cable is controlled by the FT230X IC. This FT230X device contains an MTP which contains the USB configuration descriptors for that device. When the cable is plugged into a PC or a USB reset is performed, the PC will read these descriptors. The default values stored into the internal MTP are defined in Table 0.1

Parameter	Value	Notes
USB Vendor ID (VID)	0403h	FTDI default VID (hex)
USB Product ID (PID)	6015h	FTDI default PID (hex)
Serial Number Enabled?	Yes	
Serial Number	See Note	A unique serial number is generated and programmed into the MTP during device final test.
Pull down I/O Pins in USB Suspend	Disabled	Enabling this option will make the device pull down on the UART interface lines when the power is shut off (PWREN# is high). Note that these are the lines between the FT232R and the RS232 line driver and not the RS232 outputs accessible on the wire ends.
Manufacturer Name	FTDI	
Product Description	See note	USBC-RS232-WE
Max Bus Power Current	90mA	
Power Source	Bus Powered	
Device Type	FT230X	
USB Version	0200	Returns USB 2.0 device description to the host. <b>Note:</b> The device is a USB 2.0 Full Speed device (12Mb/s) as opposed to a USB 2.0 High Speed device (480Mb/s).
Remote Wake Up	Disabled	
High Current I/Os	Enabled	Enables the high drive level on the UART and CBUS I/O pins. The device supports 4mA, 8mA, 12mA and 16mA drive strength settings. Default is 4mA. Note that these are the lines between the FT232R and the RS232 line driver and not the RS232 outputs accessible on the wire ends.
Load VCP Driver	Enabled	Makes the device load the VCP driver interface.
Invert TXD	Disabled	Signal on this pin becomes TXD# if enable.
Invert RXD	Disabled	Signal on this pin becomes RXD# if enable.
Invert RTS#	Disabled	Signal on this pin becomes RTS if enable.
Invert CTS#	Disabled	Signal on this pin becomes CTS if enable.

**Table 0.1 Default Internal EEPROM Configuration**

The internal MTP in the cable can be re-programmed over USB using the utility program FT\_Prog. The latest version can be downloaded here: [FT\\_Prog](#). Users who do not have their own USB Vendor ID but who would like to use a unique Product ID in their design can apply to CP for a free block of unique PIDs. Contact CP [support@connectiveperipherals.com](mailto:support@connectiveperipherals.com)

Note that the MTP is supplied programmed ready to use for most applications. Changing the MTP settings is for advanced users only. Changing the settings can cause incorrect operation of the device. Before editing the VID or PID, note that this requires the user to have a driver with matching VID/PID in order to install the device before it can be used again. It is recommended to contact technical support if in doubt before making any changes.

## Appendix B - List of Figures and Tables

### List of Figures

Figure 1.1 Using the USBC-FS-RS232-0V-1800-WE.....	1
Figure 4.1 USBC-FS-RS232-0V-1800-WE Connections .....	7
Figure 4.2 USBC-FS-RS232-0V-1800-WE Mechanical Details (dimensions in mm) .....	7
Figure 5.1 Circuit Schematic of PCB Used in the USBC to RS232 Serial Converter Cable .....	9

### List of Tables

Table 1.1 USBC-FS-RS232-0V-1800-WE Descriptions and Part Numbers.....	2
Table 4.1 USBC-FS-RS232-0V-1800-WE Signal Descriptions .....	7
Table 4.2 USBC-FS-RS232-0V-1800-WE I/O Operating Parameters.....	8
Table 3.3 USBC-FS-RS232-0V-1800-WE I/O Pin Characteristics.....	8
Table 0.1 Default Internal EEPROM Configuration.....	11

## Appendix C - Revision History

<b>Revision</b>	<b>Changes</b>	<b>Date</b>
Version 1.0	Initial Release	29-07-2020
Version 1.1	Updated the Part Number & Device Description Updated the Default Internal EEPROM Configuration table	07-10-2020
Version 1.2	Updated the Part Number	06-11-2020
Version 1.3	Added driver install section and other minor updates	30-01-2023