



DuoEtte

USB to RS232 Adapter

Data Sheet

Document Reference No.: CP_000058

Version 1.0

Issue Date: 2019-03-28

Part Number
DuoEtte

DuoEtte is a USB to full-handshake RS232 converter with a male DB9 connector. This adapter is sold with a 15cm USB extension cable.

Connective Peripherals Pte Ltd
178 Paya Lebar Road, #07-03 Singapore 409030
Tel.: +65 67430980 Fax: +65 68416071

E-Mail (Support): support@connectiveperipherals.com Web: www.connectiveperipherals.com/products

Neither the whole nor any part of the information contained in, or the product described in this manual, may be adapted or reproduced in any material or electronic form without the prior written consent of the copyright holder. This product and its documentation are supplied on an as-is basis and no warranty as to their suitability for any particular purpose is either made or implied. Connective Peripherals Pte Ltd will not accept any claim for damages howsoever arising as a result of use or failure of this product. Your statutory rights are not affected. This product or any variant of it is not intended for use in any medical appliance, device or system in which the failure of the product might reasonably be expected to result in personal injury. This document provides preliminary information that may be subject to change without notice. No freedom to use patents or other intellectual property rights is implied by the publication of this document. Connective Peripherals Pte Ltd, 178 Paya Lebar Road, #07-03 Singapore 409030. Registered Number: 201617872E

Table of Contents

1	Introduction	3
1.1	Functional Description	3
1.2	Features	3
1.3	Block Diagram	4
1.4	LED Description	4
1.5	Ordering Information	4
2	Driver Support	5
3	Electrical Details	6
4	DuoEtte Signals and Pin Out	7
4.1	RS232 Signals	7
4.2	USB Signals	7
5	DuoEtte Circuit Schematic	8
6	Internal MTP ROM Configuration	9
7	Module Dimensions	10
8	Environmental Approvals & Declarations	12
8.1	EMI Compatibility	12
8.2	Safety	12
8.3	Environmental	12
8.4	Reliability	12
8.5	Import / Export Information	13
9	Troubleshooting	14
9.1	Device Driver	14
9.2	Technical Support	14
10	Contact Information	15
Appendix A – List of Figures and Tables		16
	List of Figures	16
	List of Tables	16
Appendix B – Revision History		17

1 Introduction

1.1 Functional Description

The DuoEtte is a USB to RS232 level full-handshake UART adapter, based on FTDI's FT231XS USB to full-handshake UART IC. A male DB9 (also known as DE9) connector provides the connectivity for RS232 communications and a USB-Micro B receptacle provides connectivity for USB communications.

All components used are Pb-free (RoHS compliant).

Compatible with Windows 8 when using the latest drivers from the Connective Peripherals website below:
<https://www.connectiveperipherals.com>.

1.2 Features

- Provides single RS232 port on DB9 connector with easy plug & play installation
- Microsoft Windows® WHQL-certified, Mac OS X, Linux and Windows CE device drivers
- Windows support includes XP, Vista, Windows 7 and Windows 8
- Installs as standard Windows COM port which can be used with any existing application which uses a COM port
- COM port number can be changed to any available COM port number, to support HyperTerminal, or any other serial communications software application running in Windows
- Serial Communication Parameters
 - Parity: None, Even, Odd
 - Data bits: 7, 8
 - Stop bits: 1, 2
 - Flow control: Hardware, X-ON/X-OFF, None
- Data transfer rates from 300 baud to 250 Kbaud at RS232 voltage levels.
- 512 byte receive buffer and 512 byte transmit buffer utilising buffer smoothing technology to allow for high data throughput
- LEDs indicate Receive Data transfer (green) and Transmit Data transfer (red)
- ESD protection on RS232 I/Os exceeding $\pm 15\text{kV}$ IEC1000-4-2 Air Gap Discharge, $\pm 15\text{kV}$ for Human Body Mode (HBM) and $\pm 8\text{kV}$ IEC1000-4-2 Contact Discharge
- ESD protection on USB lines exceeding $\pm 2\text{kV}$ for Human Body Mode (HBM), $\pm 200\text{V}$ for Machine Mode (MM) and $\pm 500\text{V}$ for Charged Device Mode (CDM)
- Integrated MTP-ROM for storing USB VID, PID, serial number and description strings
- Powered from USB port so no external supply required. Low operating and USB suspend current
- USB 2.0 Full Speed compatible with low USB bandwidth consumption
- -40°C to $+85^{\circ}\text{C}$ extended operating temperature range
- Latch-up Free

Note: Windows CE5.0 can only support COM0~COM9. When the FTDI COM ports are assigned numbers above the Windows CE available COM ports, you cannot use the FTDI COM port.

Note: HyperTerminal is no longer provided with Windows 7/Vista.



1.3 Block Diagram

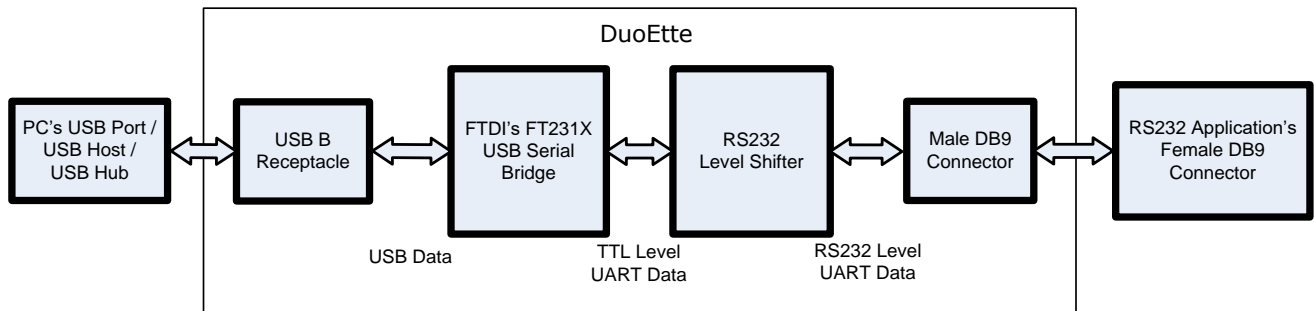

Figure 1.1 - DuoEtte Block Diagram

1.4 LED Description

The DuoEtte has two LEDs, which indicate a valid link as well as data traffic according to the following table:

LED Colour	Function	Description	LED quantity
Green	Rx Activity	Flashes when data is received by the DuoEtte	1
Red	Tx Activity	Flashes when data is transmitted by the DuoEtte	1

Table 1.1 - LED Description

1.5 Ordering Information

Part Number	Description
DuoEtte	USB to RS232 Adapter

Table 1.2 - Ordering Information

2 Driver Support

Driver support for the DuoEtte device includes the following operating systems.

The drivers listed below are all available to download for free from the following page:
<https://www.connectiveperipherals.com>.

Royalty-Free VIRTUAL COM PORT (VCP) DRIVERS for:

- Windows 8, 8.1 32/64-bit
- Windows 7 32,64-bit
- Windows Vista
- Windows XP 32,64-bit
- Windows XP Embedded
- Windows CE.NET 4.2 , 5.0 and 6.0
- MAC OS OS-X
- Linux 3.0
- Android
- Royalty-Free D2XX Direct Drivers (USB Drivers + DLL S/W Interface):
- Windows 8 8, 8.1 32/64-bit
- Windows 7 32,64-bit
- Windows Vista
- Windows XP 32,64-bit
- Windows XP Embedded
- Windows CE.NET 4.2, 5.0 and 6.0
- MAC OS OS-X
- Linux 3.0 or later
- Android OS 3.2 or later

For a full list of supported OS please see the driver link at <https://www.connectiveperipherals.com>.

3 Electrical Details

Parameter	Description	Minimum	Typical	Maximum	Units	Conditions
Vtrans	Transmitter output voltage swing	± 5	± 6.5	± 15	V	
Vrec	Receiver input voltage range	-25		+25	V	

Table 3.1 – DuoEtte - I/O Characteristics

Description	Conditions	Minimum	Typical	Maximum
ESD HBM	RS-232 Inputs and Outputs		±15 kV	
EN61000-4-2 Contact Discharge	RS-232 Inputs and Outputs		±8 kV	
EN61000-4-2 Air Gap Discharge	RS-232 Inputs and Outputs		±15 kV	

Table 3.2 – DuoEtte - ESD Tolerance

4 DuoEtte Signals and Pin Out

4.1 RS232 Signals

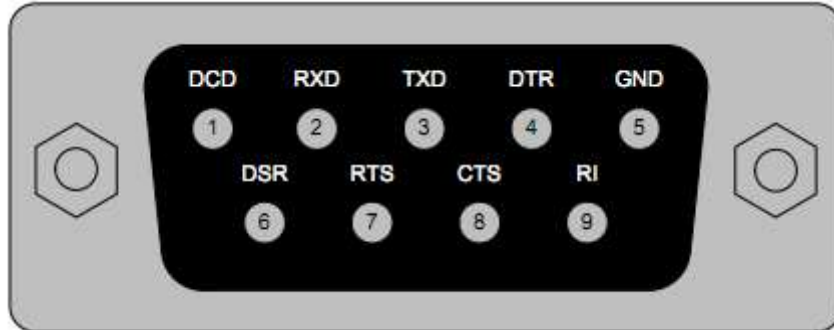

Figure 4.1 – DuoEtte DB9 Pin Out

DB9 pin No.	Name	Type	Description
1	DCD	Input	Data Carrier Detect control input
2	RXD	Input	Receive Asynchronous Data input
3	TXD	Output	Transmit Asynchronous Data output
4	DTR	Output	Handshake signal: Data Terminal Ready control output
5	GND	Ground	Device ground supply pin
6	DSR	Input	Handshake signal: Data Set Ready control input
7	RTS	Output	Handshake signal: Request To Send Control Output
8	CTS	Input	Handshake signal: Clear to Send Control input
9	RI	Input	Ring Indicator control input. When remote wakeup is enabled in the FT231XS's internal MTP-ROM taking RI# low can be used to resume the PC USB host controller from suspend

Table 4.1 – DuoEtte DB9's RS232 Signals

4.2 USB Signals

USB pin No.	Name	Type	Description
1	VBUS	Power	5V power
2	DM	Signal	USB data
3	DP	Signal	USB data
4	ID	NC	Not connected
5	GND	Ground	Ground

Table 4.2 – DuoEtte USB Lines

5 DuoEtte Circuit Schematic

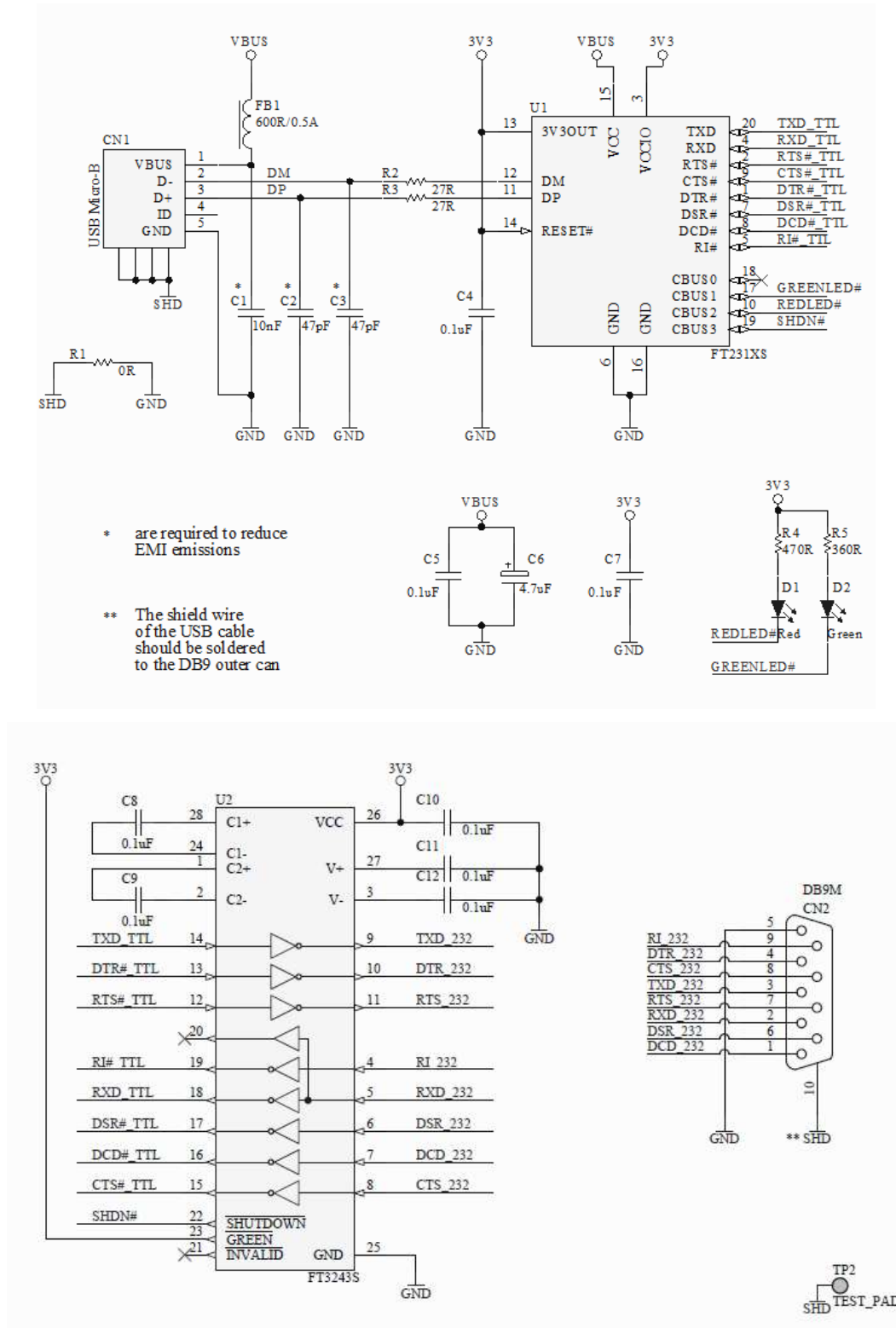

Figure 5.1 – DuoEtte Circuit Schematic

6 Internal MTP ROM Configuration

Following a power-on reset or a USB reset the FT231X will scan its internal MTP ROM and read the USB configuration descriptors stored there. The default values programmed into the internal MTP ROM in the FT231XS used by DuoEtte are shown below.

Parameter	Value	Notes
USB Vendor ID (VID)	0403h	FTDI default VID (hex)
USB Product UD (PID)	6015h	FTDI default PID (hex)
Serial Number Enabled?	Yes	
Serial Number	See Note	A unique serial number is generated and programmed into the MTP ROM during final test of the DuoEtte module.
Pull down I/O Pins in USB Suspend	Disabled	Enabling this option will make the device pull down on the UART interface lines when the power is shut off (PWREN# is high)
Manufacturer Name	FTDI	
Product Description	DuoEtte	
Max Bus Power Current	90mA	
Power Source	Bus Powered	
Device Type	FT231X	
USB Version	0200	Returns USB 2.0 device description to the host. Note: The device is a USB 2.0 Full Speed device (12Mb/s) as opposed to a USB 2.0 High Speed device (480Mb/s)
Remote Wake Up	Enabled	Taking RI# low will wake up the USB host controller from suspend
High Current I/Os	Disabled	Enables the high drive level on the UART and CBUS I/O pins
Load VCP Driver	Enabled	Makes the device load the VCP driver interface for the device
CBUS0	Tristate	
CBUS1	RXLED#	
CBUS2	TXLED#	
CBUS3	SLEEP#	
Invert UART	Disabled	

Table 6.1 – Default Internal MTP ROM Configuration

7 Module Dimensions

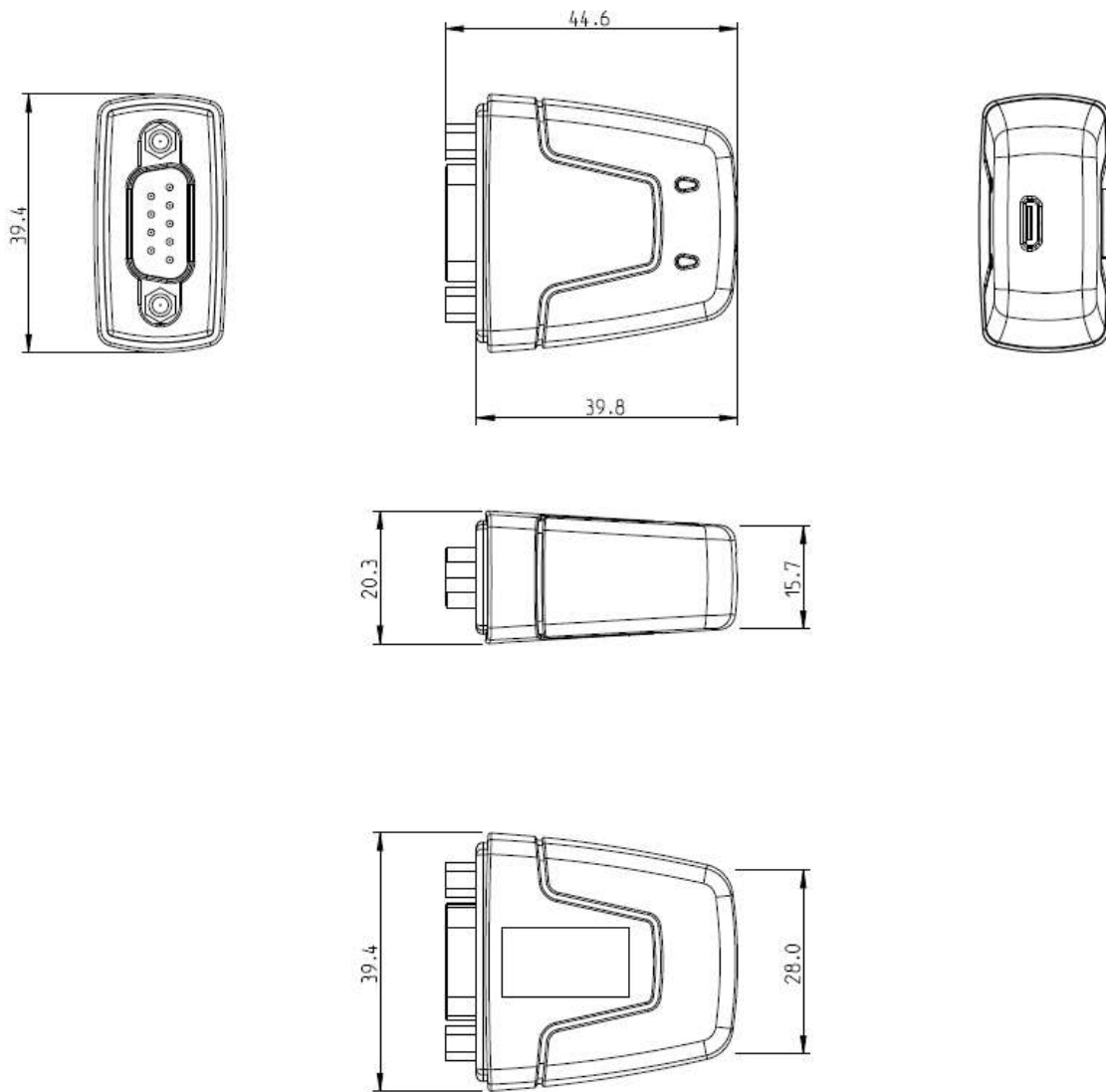

Figure 7.1 – DuoEtte Dimensions

All dimensions are given in millimetres.

DuoEtte only use lead free components, and are fully compliant with European Union directive 2002/95/EC.

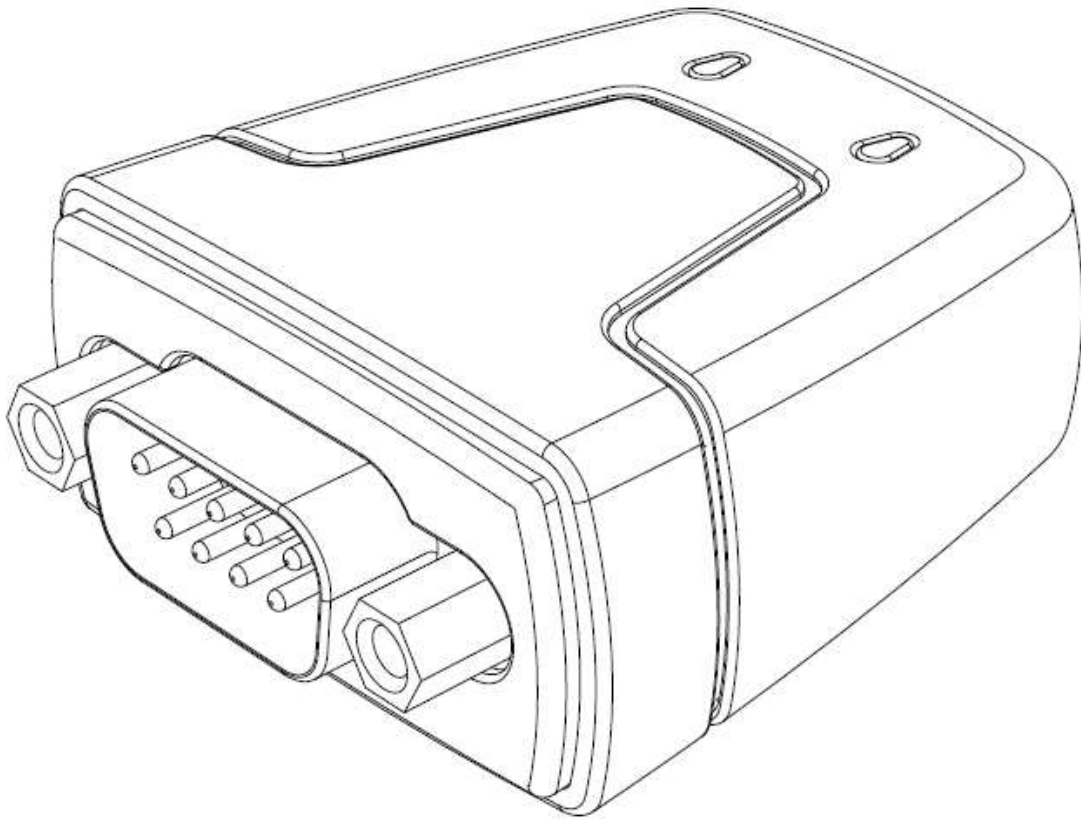

Figure 7.2 - DuoEtte

8 Environmental Approvals & Declarations

8.1 EMI Compatibility

FCC and CE

The DuoEtte has been tested to be compliant with both FCC Part 15 Subpart B and European EMC Directive.



NOTE: This is a Class B product. In a domestic environment, this product may cause radio interference, in which case the user may be required to take adequate measures.



NOTE: This equipment has been tested and found to comply with the limits for a Class B digital device, pursuant to Part 15 of the FCC Rules. These limits are designed to provide reasonable protection against harmful interference in a residential installation. This equipment generates uses and can radiate radio frequency energy and, if not installed and used in accordance with the instructions, may cause harmful interference to radio communications. However, there is no guarantee that interference will not occur in a particular installation. If this equipment does cause harmful interference to radio or television reception, which can be determined by turning the equipment off and on, the user is encouraged to try to correct the interference by one or more of the following measures:

- Reorient or relocate the receiving antenna.
- Increase the separation between the equipment and receiver.
- Connect the equipment into an outlet on a circuit different from that to which the receiver is connected.
- Consult the dealer or an experienced radio/TV technician for help.

8.2 Safety

The DuoEtte is defined as Limited Power Supply (LPS) device, with operating voltages under 60VDC.

8.3 Environmental

The DuoEtte is a lead-free device that complies with the following environmental directives: RoHS, WEEE, and PFOS.

8.4 Reliability

The DuoEtte is designed as a robust USB-Serial module for use in many environments. There are no user-serviceable parts. Any failure will require a replacement of the unit.

8.5 Import / Export Information

Import / Export Information	
Country of Origin	China
US Harmonized Code	8471.80.1000
UK Commodity Code	84719000
Product Description	USB to RS232 Adapter
USA ECCN	EAR99 – No License Required

Table 8.1 - Import / Export Information

9 Troubleshooting

9.1 Device Driver

Ensure the latest device driver is in use. See the following link for the latest drivers:

<https://www.connectiveperipherals.com>

If other devices with FTDI chips are installed in the system, check with all manufacturers of these devices for the latest device drivers.

See the installation guides for additional installation instructions for your operating system:
<http://www.ftdichip.com/Documents/InstallGuides.htm>

Common Windows Device Driver Troubles:

- **DEVICE TIMES OUT:** The default settings of the device driver assume typical data transfers of hundreds to thousands or more bytes at a given time. Some applications, such as a GPS device, only send data in short packets, often only a few bytes. If this is the case, it may be necessary to adjust the driver buffer size and/or latency timer to smaller values. These values can be adjusted through the advanced driver options which can be accessed by double-clicking on the device under the Ports (COM & LPT) section of the Windows Device Manager and clicking the advanced button in the Port Settings tab. The buffer size can be reduced to 64 bytes. The latency timer can be set as low as 2ms. A setting of 1ms will cause unnecessary USB traffic and could adversely affect data transmission.
- **ERRATIC MOUSE POINTER:** The device driver defaults to query an attached device to find out whether it is a mouse or modem, consistent with native COM port operation. Some peripherals constantly send short packets of data, causing the host system to “think” a mouse or modem has been attached. These short packets will interfere with normal mouse operation causing the pointer to jump around the screen. If this happens, disconnect the RS232 device and *uncheck the Serial Enumerator* option. This option can be adjusted through the advanced driver options which can be accessed by double-clicking on the device under the Ports (COM & LPT) section of the Windows Device Manager and clicking the advanced button in the Port Settings tab.
- **COM PORT IN USE:** Windows keeps track of all COM port assignments. If multiple FTDIChip products have been connected to a single system, the COM port number will increase, even if the other devices are not attached. If the higher COM port assignments are not acceptable for the application, known unused COM port numbers should be uninstalled according to the FTDI installation guide: <http://www.ftdichip.com/Documents/InstallGuides.htm>.

9.2 Technical Support

Technical support may be obtained from your nearest Connective Peripherals Office:

support@connectiveperipherals.com

<https://www.connectiveperipherals.com>

You can find the latest information and product downloads at the link below.

<https://www.connectiveperipherals.com>

10 Contact Information

Global Headquarters – Singapore

Connective Peripherals Pte Ltd
178 Paya Lebar Road
#07-03
Singapore 409030

Tel: +65 67430980
Fax: +65 68416071

E-Mail (Sales)	sales@connectiveperipherals.com
E-Mail (Support)	support@connectiveperipherals.com
Web Site URL	http://www.connectiveperipherals.com
Web Shop URL	http://www.connectiveperipherals.com

Appendix A – List of Figures and Tables

List of Figures

Figure 1.1 - DuoEtte Block Diagram	4
Figure 4.1 – DuoEtte DB9 Pin Out	7
Figure 5.1 – DuoEtte Circuit Schematic.....	8
Figure 7.1 – DuoEtte Dimensions	10
Figure 7.2 – DuoEtte	11

List of Tables

Table 1.1 – LED Description	4
Table 1.2 - Ordering Information	4
Table 3.1 – DuoEtte - I/O Characteristics	6
Table 3.2 – DuoEtte - ESD Tolerance.....	6
Table 4.1 – DuoEtte DB9’s RS232 Signals	7
Table 4.2 – DuoEtte USB Lines	7
Table 6.1 – Default Internal MTP ROM Configuration	9
Table 8.1 - Import / Export Information	13

Appendix B – Revision History

Revision	Changes	Date
Draft	Initial release	2015-06-18
1.0	Re-branding to reflect the migration of the product from EasySync to Connective Peripherals name – logo change, copyright changed, contact information Changed, all internal hyperlinks changed.	2019-03-28