



# **Connectorized LEDs & LED Drivers**

User Manual

Version 1.1.2

---

# Contents

<b>1 Safety Information</b>	<b>3</b>
1.1 Important Safety Information	3
<b>2 Overview</b>	<b>4</b>
2.1 Connectorized LEDs	4
2.2 LED Drivers	5
2.3 LED Breadboard	7
<b>3 Operations Guide</b>	<b>8</b>
3.1 Connectorized LED Setup	8
3.2 FC Connector Installation	9
3.3 Stand-alone mode (without Doric Neuroscience Studio Software)	10
3.4 Connected to Doric Neuroscience Studio Software	12
<b>4 Doric Neuroscience Studio</b>	<b>13</b>
4.1 Light Sources	13
<b>5 Specifications</b>	<b>22</b>
<b>6 Annex 1: Safety features</b>	<b>25</b>
6.1 Activation Safety Features	25
6.2 Emission Indicator	26
<b>7 Support</b>	<b>27</b>
7.1 Maintenance	27
7.2 Warranty	27
7.3 Contact us	27

## Safety Information

### 1.1 Important Safety Information

Light-emitting diodes (LEDs) used with sufficiently high power levels can be dangerous for the eyes. NEVER LOOK directly into the beam exiting from the FC connector of an LED module or from any optical fiber connected to the FC connector.

Doric LED Drivers are provided with a safety interlock connector on its rear panel (Fig. 1.1a). When the interlock circuit connector is shorted with the interlock plug, the driver is enabled. The shorting electric wire in the interlock plug can be removed and replaced by the safety interlock circuit of the laboratory. This safety feature is highly recommended with UV and infrared (IR) LEDs.

The **Power Key Switch** is located on the left side of the driver (Fig. 1.1b) to control the use of the device. All light sources connected to the driver can be enabled only when the power key is properly inserted.

**To be enabled, LED Drivers must have its interlock circuit connector shorted with the interlock plug and the power key properly inserted.**



Figure 1.1: Safety procedure

## Overview

## 2.1 Connectorized LEDs

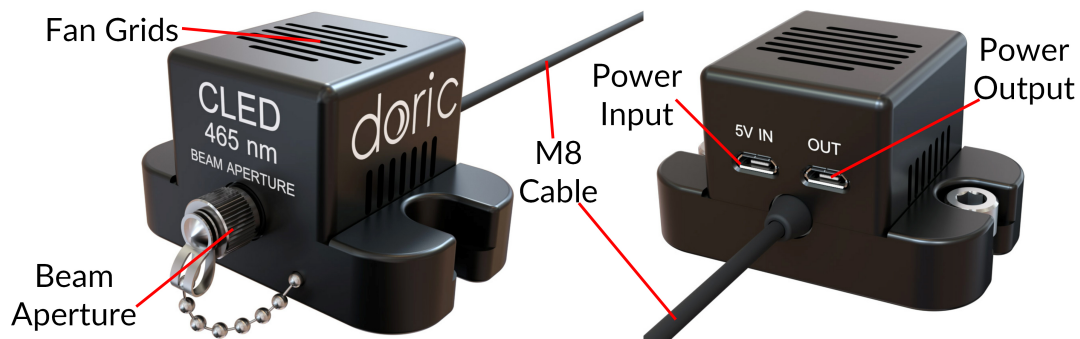

Figure 2.1: Connectorized LED

The Doric *Connectorized LED* is a compact module that couples a high brightness LED into an optical fiber via an FC receptacle. It is available in wavelengths from 365 nm to 940 nm, as well as white (5500 K temperature). The module connects to the Doric *LED Driver* over the pigtailed M8 electrical cable. Each module contains a fan, which is powered using a micro USB 5 V power supply. This fan cools the LED and allows stable output performance and long device lifespan. The following elements are found on the outside of the light source.

- The output beam exits from the **Beam aperture**. The aperture is composed of a fiber coupling assembly that injects the emitted light into an optical fiber. The standard model uses an FC fiber connector. A safety FC metal cap is attached to the optical head to block the output light beam when no patch-cord is in place.
- The **Fan grids** are found on the top and sides of the light source.
- The **M8 electrical cable** links the light source to the driver. An EPROM within the light source allows the driver to identify it when the cable is connected.
- The **Power input** is a 5 V micro-usb port used to power the fan.
- The **Power output** is a 5 V micro-usb port. A micro-usb/micro-usb cable is used links the port to the **Power input** of a different LED.

## 2.2 LED Drivers



Figure 2.2: LED Drivers; 1-, 2- and 4-channel

Doric LED Drivers can be used as a stand-alone device or controlled via USB port. Each channel connects to a single Connectorized LED which can be controlled manually or via the Doric Neuroscience Studio Software.

The LEDs drivers can be used as a stand alone device. During stand-alone operation, it is possible to change the operating mode (CW or external analog mode) and the current sent to the **Connectorized LED**. These changes can be done directly on the device with the control knobs and the LCD display.

Connecting the LED drivers to a computer provides the user with more options. Doric Neuroscience Studio Software allows the access to more operating modes like CW, external TTL, external analog, internal TTL and internal Complex modes. Doric Neuroscience Studio Software enables the creation of different sequences of light source activation. It also provides the possibility to let these sequences be triggered or paused by an external signal. If more power is needed, it is possible to overdrive the LED driver with the software. Our LED driver has a live pulse capability allowing the visualization of the signal modulation on the input BNC in a scope-like manner.

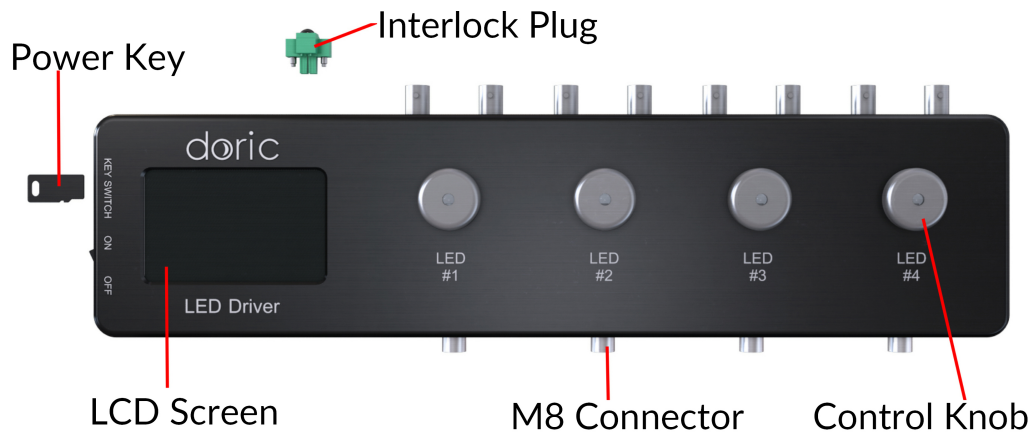

Figure 2.3: Front view of a 4-channel LED Driver

- The **LCD display** (Fig. 2.3) allows easy operation and monitoring. For each channel, the LCD displays the type of light source (LED), the operating mode, the center wavelength in nm and the current setting.

- The **Power key** must be properly inserted into the key switch to enable operation of the light source(s) connected to the driver. Note that, despite its similar shape, the power key is not a standard micro SD card such as those used in some digital cameras. Do not attach the Key to a key fob or similar holder; this may prevent proper insertion of the **Power key**.
- The **M8 connector** is used to link the driver and LED.



Figure 2.4: Rear view of a 4-channel LED Driver

- The **Interlock Connector Plug** (Fig. 2.4) allows the user to connect the driver to an interlock system. It is recommended to connect the interlock plug to a laboratory interlock system. This is critical when using LEDs in the UV or Infrared spectrum, as they are invisible to the naked eye.
- The **Input BNC** allows the control of the LED driving current of the corresponding source with an analog or TTL signal.
- The **Output BNC** are used to monitor the driving current of the corresponding light source.
- The **12 VDC power input** connects the driver to its 12 VDC power supply.
- The **USB-B Connector** allows the driver to be connected to a computer using a USB-A/USB-B cable.
- The **On/Off switch** (Fig. 2.5) turns on/off the driver.

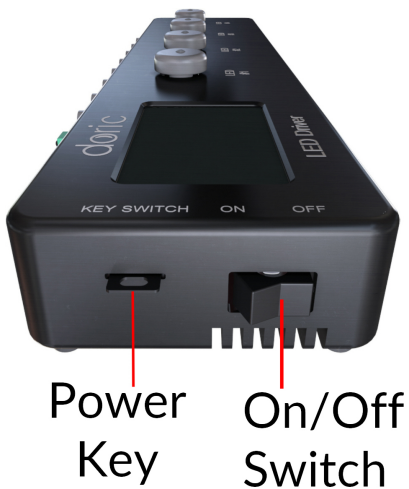

Figure 2.5: Side view of a 4-channel LED Driver

## 2.3 LED Breadboard

The **LED Breadboard** is a small breadboard used to hold two *Connectorized LEDs*; this allows the light sources to be easily moved when necessary. It is ordered separately from the light source.



Figure 2.6: LED Breadboard with LEDs Installed

## Operations Guide

### 3.1 Connectorized LED Setup

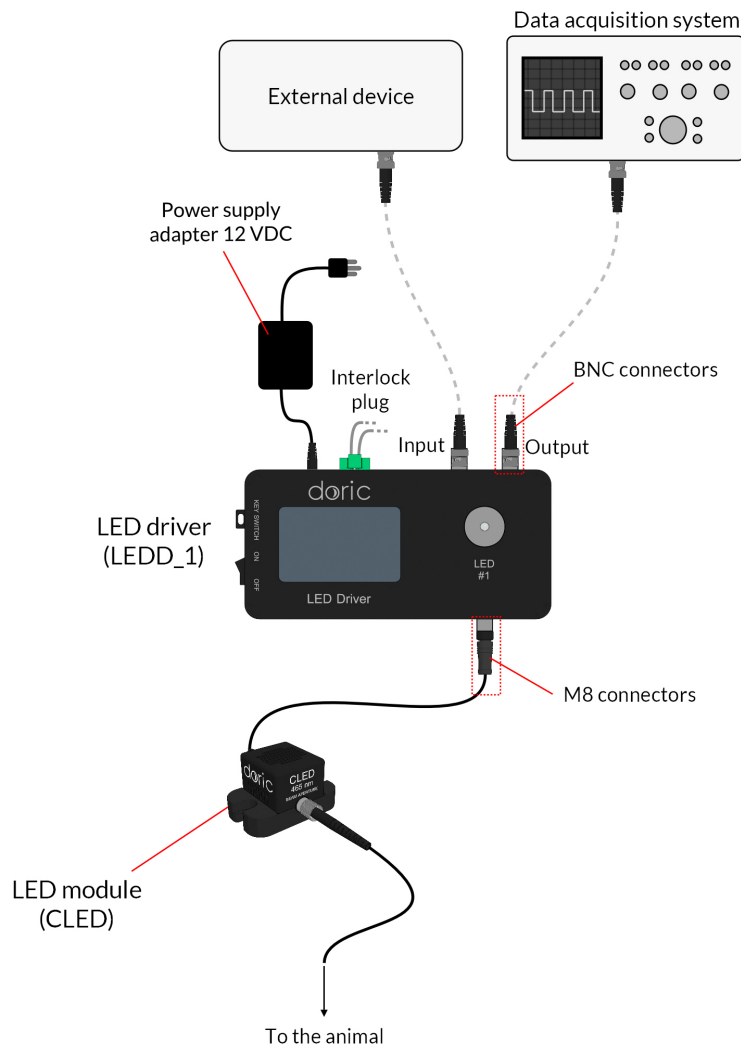

Figure 3.1: Connections to a 1-channel LED Driver in stand-alone mode

1. Connect the **LED Driver** to the **12 VDC power supply**.



2. Connect the **Connectorized LED (CLED)** to the driver. Align the M8 connector pins in the female receptacle on the Doric CLED driver, slide in and screw the nut in place.
3. Connect the 5 VDC *Micro-USB Power Supply* to the **5 V Input** of the **CLED Fan** for proper cooling of the LED.
4. For optimal performances, place the module in a well ventilated area. Overheating will affect LED power and reduce its lifetime.
  - **⚠ DO NOT connect/disconnect the optical fiber while the light source is ON.**
  - The CLED can be operated with the driver's stand-alone capabilities (Section 3.3) or using the *Doric Neuroscience Studio* software (Section 3.4).

### 3.2 FC Connector Installation

1. Clean the optical fiber connector before insertion. Use isopropanol and a lint-free wipe.
2. With an FC connector, the connector key must be oriented to enter within the receptacle slot to ensure proper connection (Fig. 3.2).

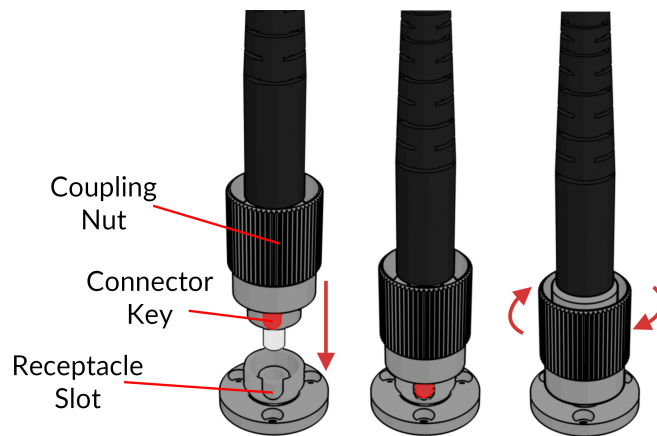

Figure 3.2: FC connector, Fiber Installation

**⚠ To reduce the risk of eye injury, it is sound practice to NOT CONNECT/DISCONNECT OPTICAL FIBERS when the light source is turned on.**

### 3.3 Stand-alone mode (without Doric Neuroscience Studio Software)

The following sections details stand-alone operation of the *LED driver*. For installation of the *LEDC* in stand-alone mode, see section 3.1.

#### 3.3.1 Driver operation modes with the stand-alone device

If the light source driver is used as a stand-alone device, 3 modes are available: constant current (CW), external TTL (Ext. TTL), and external Analog (Ext. Ana). The operating mode is changed by pressing the **Control knob**. The maximal driving current is set by turning **Control knob**. Use a fast/slow rotation for coarse/fine adjustment. The operating mode and the maximum driving current setting are independently adjusted for each channel.

##### Constant current (CW)

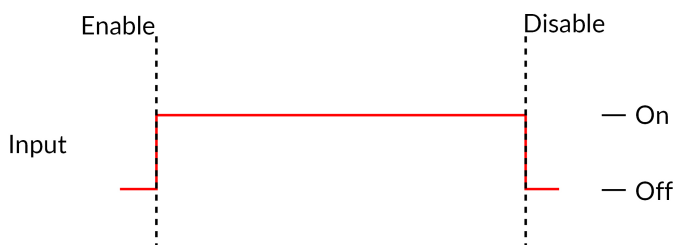

Figure 3.3: Constant Current Mode Driver Signal

When using the CW mode, the user simply sets the driving current applied to the light source. The light source is activated and an output beam will be visible as long as the driving current is above the minimum driving current (Fig. 3.3).

##### External TTL (TTL)

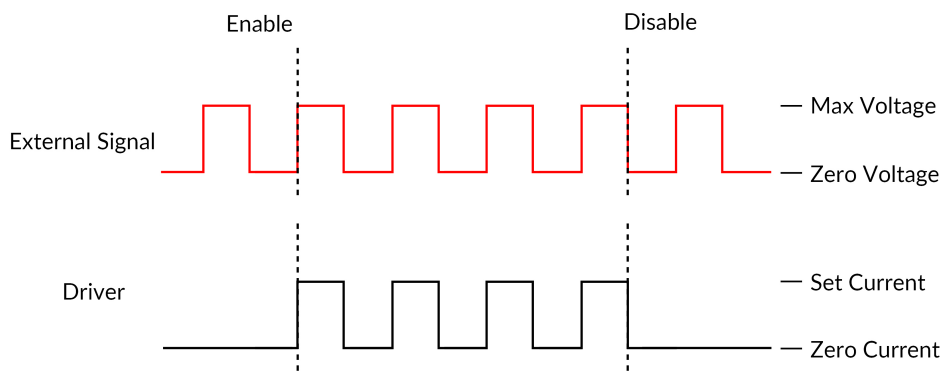

Figure 3.4: Driver Signal Response to External Source in External TTL Mode

In the External TTL mode, the driver is activated by an input TTL signal coming from an external device. This activation will follow the TTL pulse waveform. The driving current is set with the control knob, and is constant during each TTL activation pulse.

## External Analog (Ext. Ana.)

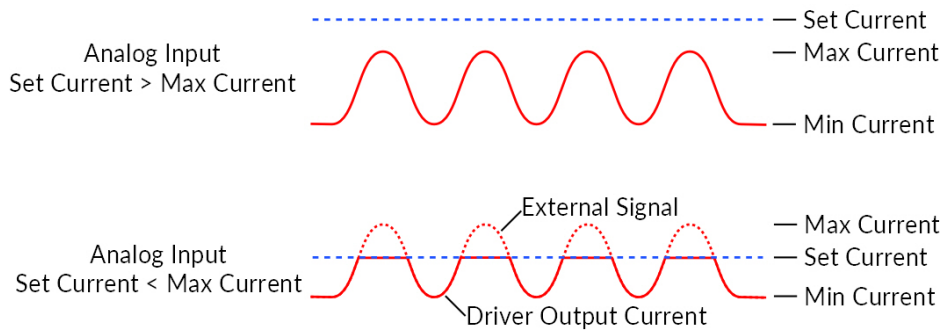

Figure 3.5: External analog pulse sequence behavior

The External Analog mode is similar to the External TTL, except that the driving current is proportional to the voltage applied on the BNC input connector (Fig. 3.5, top). On the input BNC, a maximum voltage signal corresponds to a maximum driver current. Should the current set on the light source be less than the maximum current, any voltage corresponding to a higher current will clip the output waveform (Fig. 3.5, bottom). To avoid any clipping of the output waveform, the maximum current setting must be equal to or greater than the corresponding maximum analog input voltage.

### Low power mode

To enable **Low power mode**, press the control knob for two seconds and an asterisk will appear indicating the switch to the current divide mode. This option reduces the current, therefore the optical power. It is useful to get stable signals in experiments requiring lower power (e.g. fiber photometry experiments). In this mode, the maximal current is 200 mA (corresponding to a 5 V input) and the minimum is 2.5 mA. This allows a more stable LED power output at lower electrical currents.

### 3.4 Connected to Doric Neuroscience Studio Software

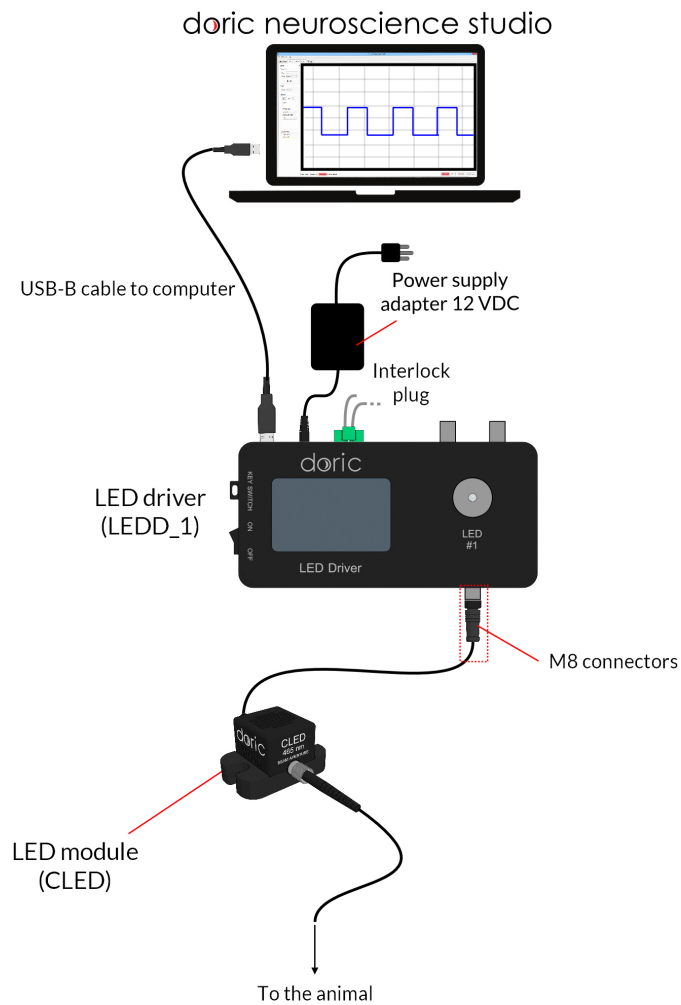

Figure 3.6: 1-channel LED Driver USB connected to Doric Neuroscience Studio Software

1. Connect the LED Driver to the power outlet with the included 12 V AC-DC adapter and turn the LED Driver switch ON. **Always power the LED Driver before connecting the USB cable to the computer for a proper driver installation.**
2. Install the Doric Neuroscience Studio Software on the computer. Double-click on the setup\_DoricStudioX.X.exe file located on Doric USB memory stick supplied with the LED driver and follow the on-screen instructions.
3. Connect the **USB cable** to the driver and the computer.
4. Connect the *Connectorized LED* to the LED driver using the M8 electric cable. The light source will be recognized by the software and will indicate the wavelength and the maximum current.
5. Connect the 5 VDC USB Mini-B Power Supply to the **5 V input** for proper cooling of the LED.
6. With the system connected, the software can be used to control the device in **External TTL, External Analog, Internal TTL and Internal Complex** modes. See section 4.1 for more details on using the software.

## Doric Neuroscience Studio

When the LED is controlled by Doric Neuroscience Studio Software, the light stimulation can be synchronized with other data acquisition.

### 4.1 Light Sources

Doric Light Sources can be controlled by the Doric Neuroscience Studio. These include *LED Modules*, *Laser Diode Modules* and *Ce:YAG Fiber Light Source*. The interface is separated into two main sections, **Control & settings** and the **Acquisition View**. Each light source driver has a number of **Channels**, each one controlling a light source of its given type. These channels, accessible using the **Add Channel** will be the first detailed.

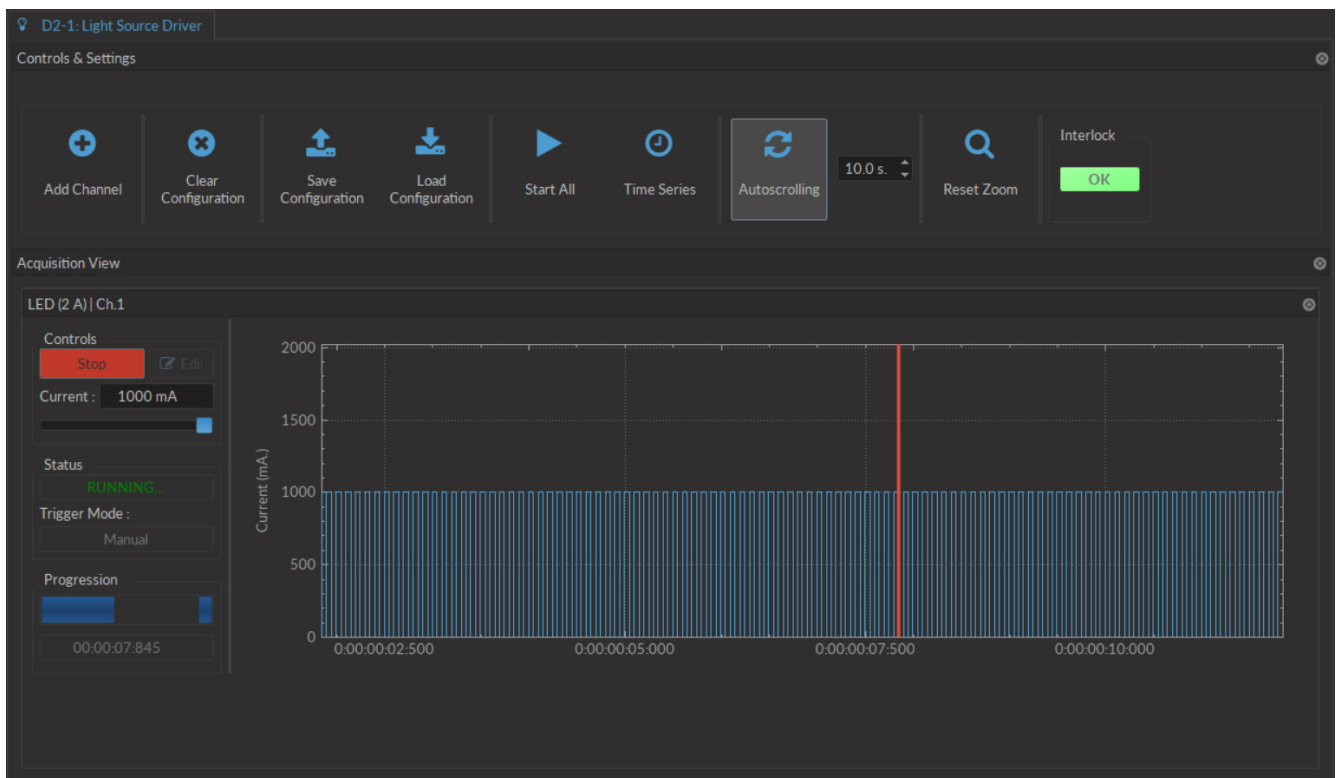

Figure 4.1: Light Source Driver Tab

#### 4.1.1 Channels

Each light source driver is separated into a number of **Channels**. Each channel controls a single light source. While each channel can be controlled in **Stand-alone** mode by the driver, additional functions can be accessed for these channels

when the driver is connected to the Doric Neuroscience Studio. These function are used through the **Channel Configuration** window (Fig. 4.2).

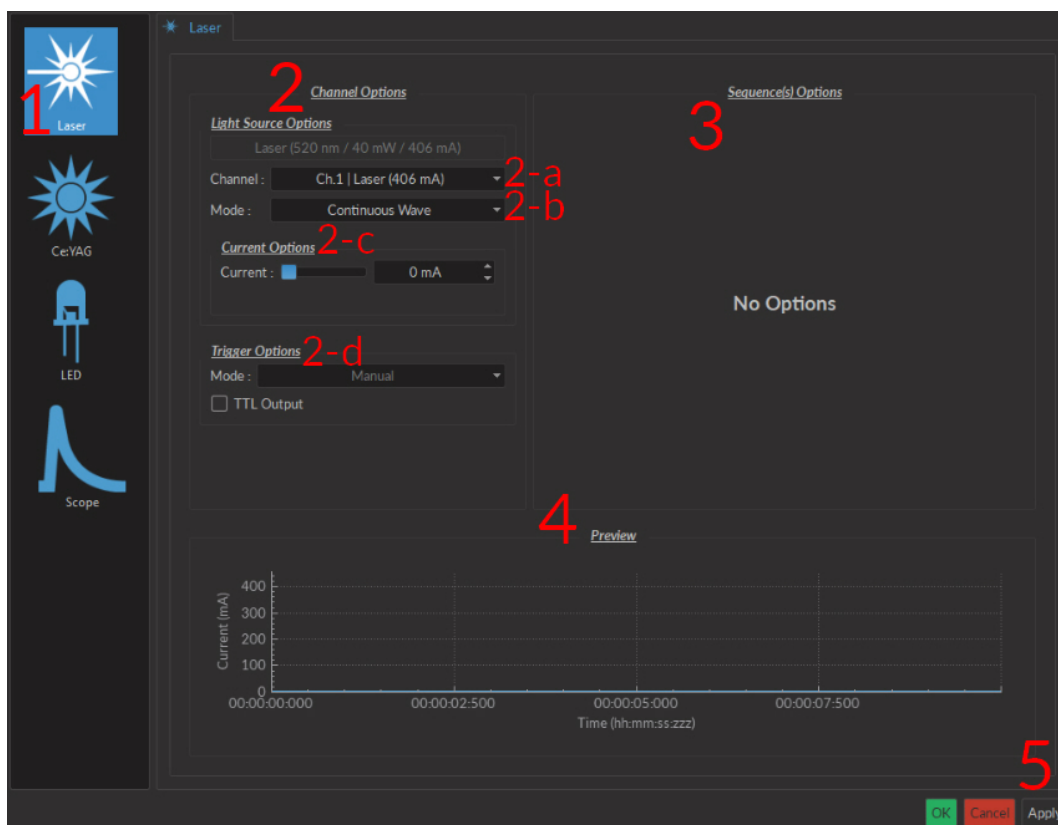

Figure 4.2: Light Source Channel Configuration Window

1. The **Channel Types** (Fig. 4.2) are displayed on the left side of the window. These include **Laser** light sources, **Ce:YAG** light sources and **LED** light sources, as well as the **Scope** to measure signal using the driver.
2. The **Channel Options** box (Fig. 4.2) includes **Light Source Options** and **Trigger Options** for the given channel.
  - a) The **Channel** (Fig. 4.2) drop-down list identifies which driver channel is currently being edited, assuming a driver with multiple channels.
  - b) The **Mode** (Fig. 4.2) drop-down list includes each possible driver mode. These are used to control the pulse sequences emitted by the light source. The options related to this mode are detailed with the **Sequence Options**.
  - c) The **Current Options** (Fig. 4.2) includes the slider used to control the current sent to the light source.
    - When using a **LED Driver** module, the **Overdrive** checkbox will appear. When selected, this allows the system to exceed the normal safe current limit of the light source. **THIS SHOULD ONLY BE USED WITH PULSED SIGNALS, AS IT CAN OTHERWISE DAMAGE THE LIGHT SOURCE.**
    - When using a **LEDD**, the **Low-Power** checkbox will appear. When selected, this allows reduced-power signaling for the same voltage. This mode is only available for **CLED** modules. This allows low-power signals to be more stable in time. The maximal current is reduced to one tenth of light source's normal maximal current. If the **BNC Output** is used, the voltage of the signal is proportional to the current passing through the light source, and not the voltage sent to it. For example, a driver with a normal maximum current of 2000 mA for a 5 V signal (400 mA/V) will have a maximum current of 200 mA for a 5 V signal (40 mA/V). The **BNC output** of the driver will still relate LED current with a 400 mA/V conversion factor.
  - d) The **Trigger Options** (Fig. 4.2) allow the selection of a number of trigger modes to activate a pulse sequence.
    - The **Manual** trigger mode is standard, and allows direction activation by the user.

- The **Triggered** trigger mode is active when an input greater than 4 V is detected on the BNC input. Following input pulses will be ignored while the sequence is running. The sequence will restart with the arrival of the first input pulse after the sequence has finished.
  - The **Gated** trigger mode is active as long as there is a high TTL signal (4 V or more) on the input modulation BNC. This signal comes from a different light source or device driver. When the TTL signal is low (0.4 V or less), the sequence stops and waits for another high TTL signal to continue.
  - If the **TTL Output** option is checked, the output BNC channel can be used as a TTL generator. The monitoring signal will provide a TTL signal instead of an analog voltage output proportional to the LED current. The output will send out a 5 V signal whenever the input current is  $>0$  mA. This can be used even if a light source is not connected.
3. The **Sequence options** box (Fig. 4.2) is where sequence options are defined depending on the mode. The **Continuous wave**, **External TTL** and **External Analog** modes have no additional sequence options.

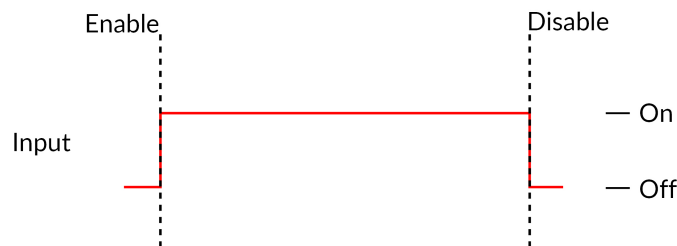

Figure 4.3: Constant Current Mode Driver Signal

- a) The **Continuous Wave** mode (Fig. 4.3) produces a continuous signal at the chosen current. This mode can only be triggered manually. When this mode is active, the driver channel will show **CW** under **MODE**. This mode has no additional sequence options.

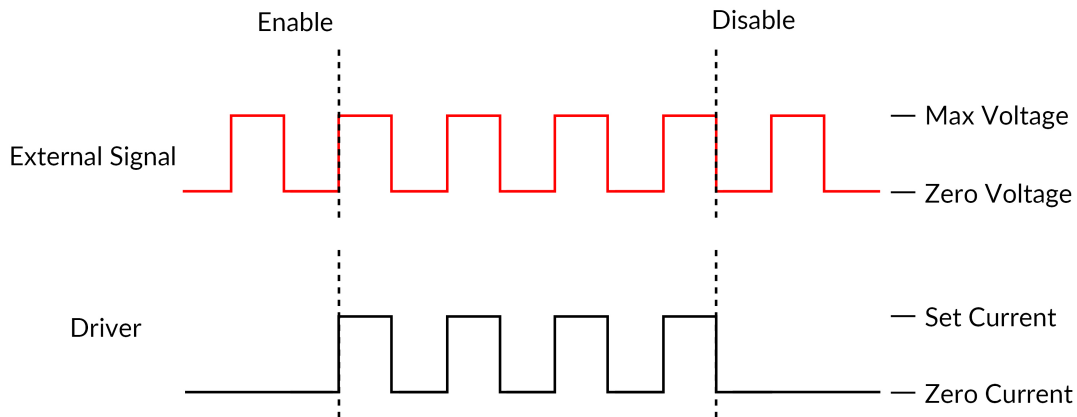

Figure 4.4: Driver Signal Response to External Source in External TTL Mode

- b) The **External TTL** mode (Fig. 4.4) has the light source follow a TTL signal provided by an external source connected to the **BNC Input**. When this mode is active, the driver channel will show **TTL** under **MODE**. This mode has no additional sequence options.
- c) The **External Analog** mode (Fig. 4.5) is similar to the External TTL, except that the current will be set by the voltage on the BNC input (Fig. 4.5, top). On the input BNC, a maximum voltage signal corresponds to a maximum driver current. Should the current set on the light source be less than the maximum current, any voltage corresponding to a higher current will clip the output waveform (Fig. 4.5, bottom). To avoid any clipping of the output waveform, the maximum current setting must be equal to or greater than the corresponding maximum analog input voltage. See the corresponding light source manual to find the voltage/current relationship. This mode has no additional sequence options.

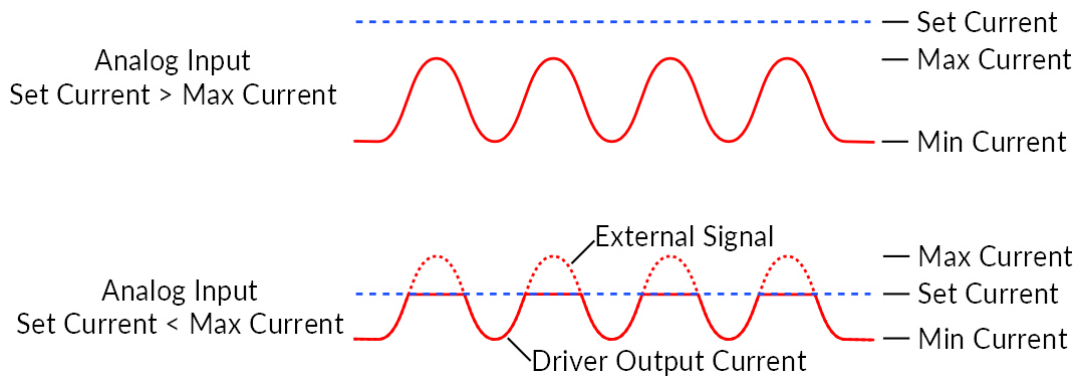

Figure 4.5: Driver and Light Source in External Analog Mode

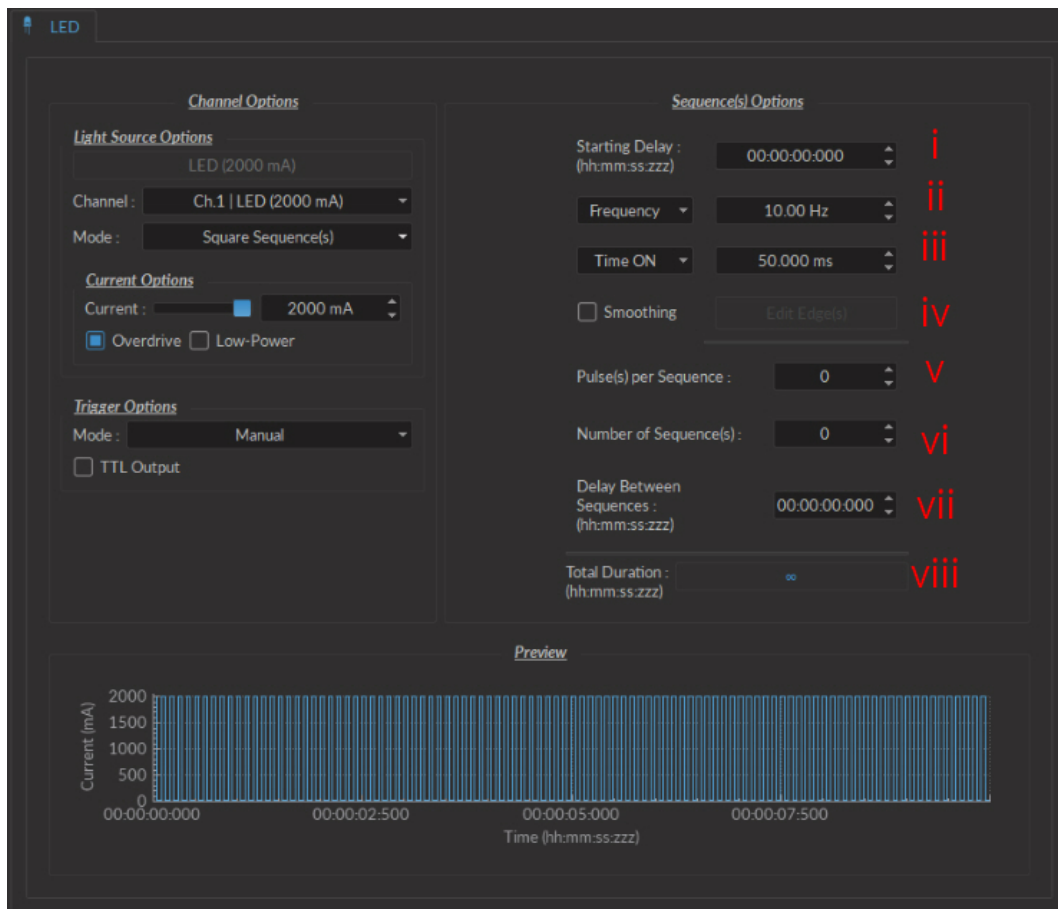

Figure 4.6: Light Source Channel Configuration Window, square sequence options

- d) The **Square sequences** mode has the light source follow a square pulse sequence.
- i. The **Starting Delay** (Fig. 4.6) sets the delay (in hh:mm:ss:zzz format) before the first pulse.
  - ii. The **Frequency/Period** (Fig. 4.6) sets the frequency (in Hz) or period (in ms) for the pulse sequence. For example, a signal at 10 Hz (frequency) will output one pulse every 100 ms (period), whereas a pulse sequence at 0.5 Hz (frequency) will output one pulse every 2000 ms (period).
  - iii. The **Time ON/Duty Cycle** (Fig. 4.6) sets the time (in ms) or the duty cycle (in %) for each pulse. The **Time ON** must be lower than  $(1/\text{frequency}) + 0.005$  ms, while the **Duty cycle** must be below 100 %. These squares will appear red should an impossible **Frequency/time ON** be selected. Should the **Smoothing** option be selected, this feature becomes inaccessible.



- iv. The **Smoothing** option is used to change the pulse slope in square pulse sequences. The **Edit Edges** button opens the **Smoothing Edge(s)** window (Fig. 4.7).

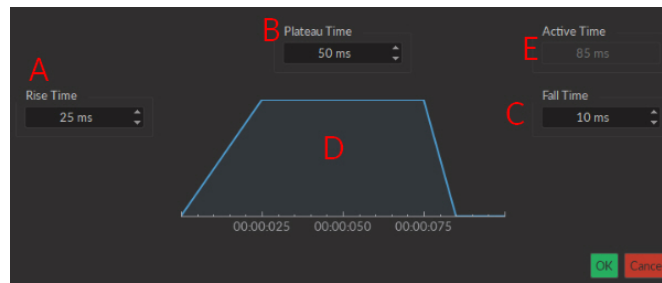

Figure 4.7: Light Source Smoothing Edge(s) Window

- A. The **Rise Time** box is used to define the duration to rise from 0 to the pulse maximum.
- B. The **Plateau Time** box is used to defined the duration the pulse is at its maximum value.
- C. The **Fall Time** box is used to define the duration to descend from the pulse maximum to 0.
- D. The **Pulse Graph** displays the pulse shape.
- E. The **Active Time** box displays the total duration of the pulse. While the **Smoothing** option is active, the **Time ON** is fixed at this value.
- v. The **Pulses per sequence** (Fig. 4.6) sets the number of pulses per sequence. If it is set to 0, the pulse will be repeated indefinitely.
- vi. The **Number of sequences** (Fig. 4.6) sets the number of times that the sequence will be repeated. If it is set to 0, the sequence will be repeated indefinitely.
- vii. The **Delay between sequences** (Fig. 4.6) sets the delay (in hh:mm:ss:zzz format) between each sequence if the **Number of Sequences** is greater than 1.
- viii. The **Total Duration** (Fig. 4.6) displays the total time of the experiment. The different values can be *Inf* for infinite, a valid time value or *Err* if the **Time ON** value is greater than 1/frequency.

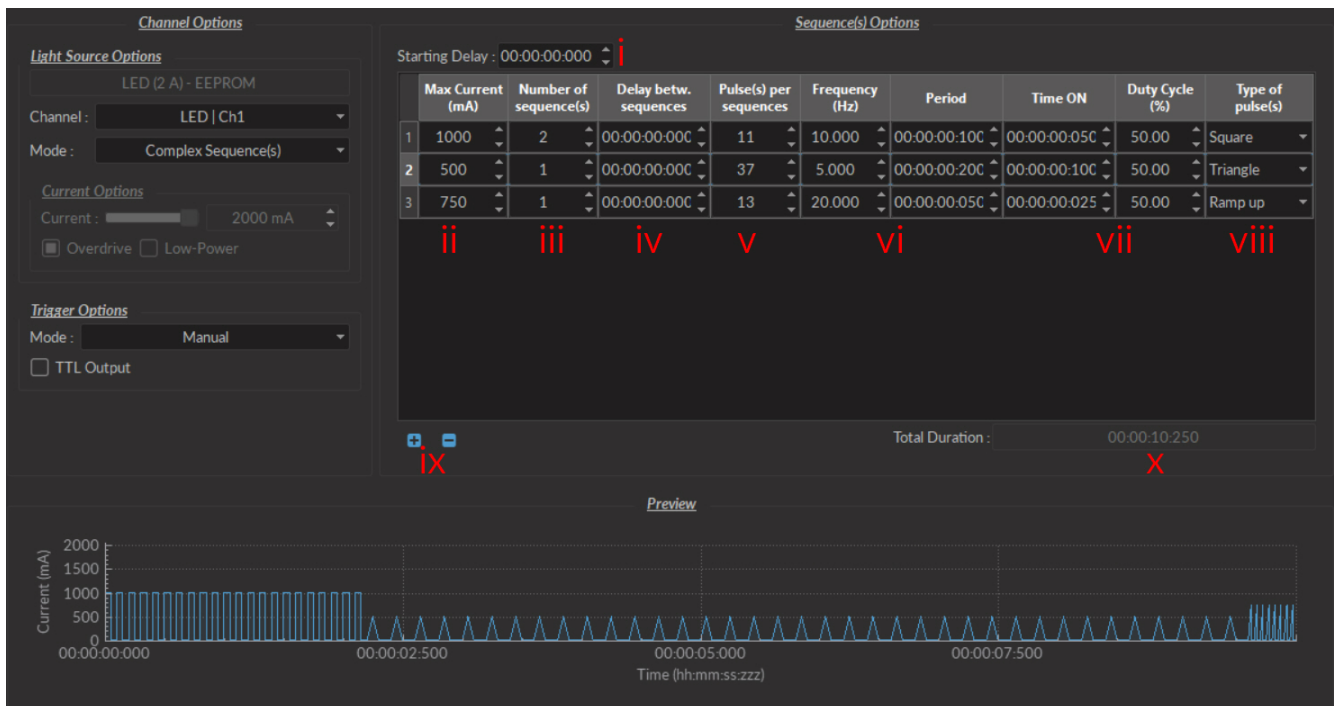

Figure 4.8: Complex Sequences Window

- e) The **Complex Sequences** mode mode allows the design of complex pulse sequences. Multiple sequences can be combined to create a more elaborate pulse sequence. These are displayed in a spreadsheet format.
- The **Starting Delay** (Fig. 4.8) sets the delay (in hh:mm:ss:zzz format) before the first pulse sequence.
  - The **Max Current** (Fig. 4.8) sets the maximum current (in mA) for the given sequence.
  - The **Number of sequences** (Fig. 4.8) sets the number of times that the sequence will be repeated, with a minimum of 1.
  - The **Pulses per sequence** (Fig. 4.8) sets the number of pulses per sequence, with a minimum of 1.
  - The **Delay between sequences** (Fig. 4.8) sets the delay (in hh:mm:ss:zzz format) between each sequence if the **Number of Sequences** is greater than 1.
  - The **Frequency/Period** (Fig. 4.8) sets the frequency (in Hz) or period (in ms) for the pulse sequence. These two values are linked, and when one is changed the other will adjust automatically. For example, a signal at 10 Hz (frequency) will output one pulse every 100 ms (period), whereas a pulse sequence at 0.5 Hz (frequency) will output one pulse every 2000 ms (period).
  - The **Time ON/Duty Cycle** (Fig. 4.8) sets the time (in ms) or the duty cycle (in %) for each pulse. These two values are linked, and when one is changed the other will adjust automatically. The **Time ON** must be lower than  $(1/\text{frequency})+0.005$  ms, while the **Duty cycle** must be below 100 %.

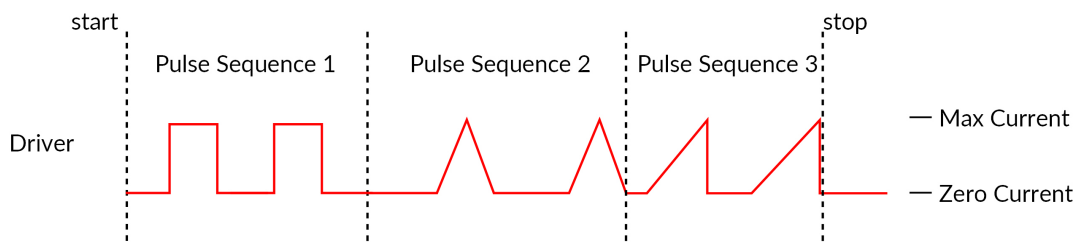

Figure 4.9: Internal Complex Mode Pulse Sequences

- The **Types of pulses** (Fig. 4.8) sets the pulse type. Pulses can be **Square**, triangular (**Triangle**), **Ramp up** **Ramp down** or **Delay** (Fig. 4.9). The **Delay** pulse type is used to create a delay between different sequence
  - The **Sequence controls** (Fig. 4.8) allow the addition (+) or removal (-) of sequences to the spreadsheet.
  - The **Total Duration** (Fig. 4.8) displays the total time of the experiment. The different values can be *Inf* for infinite, a valid time value or *Err* if the **Time ON** value is greater than  $1/\text{frequency}$ .
- f) The **Scope** mode allows the measurement of electrical signal using the driver (Fig. 4.10). The signal is received by the Input BNC of the chosen channel on the light source driver.

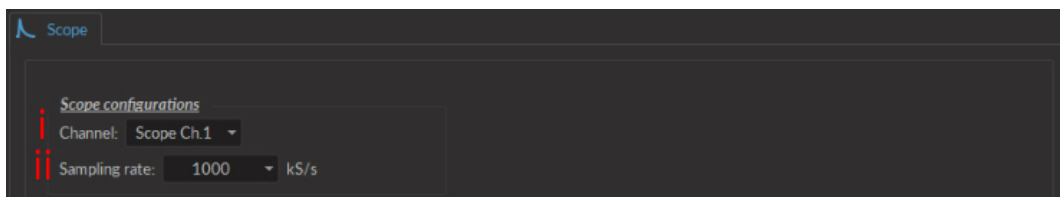

Figure 4.10: Scope

- The **Channel** drop-down list indicated which driver channel will be used to receive signal. The chosen can be used to drive a light source while serving as a scope.
  - The **Sampling Rate** drop-down list allows the selection of the rate (in kilosamples per second) at which measurements are taken.
- The **Preview** box (Fig. 4.2) displays a preview of the chosen sequence while in the **Continuous Wave**, **Square Sequences** and **Complex Sequences** mode.
  - The **Apply** button (Fig. 4.2) will generate the defined channel OR update an already configured channel with any changes.

## 4.1.2 Control & Settings

The **Control & settings** sections is used to control the light source. It includes the following elements.

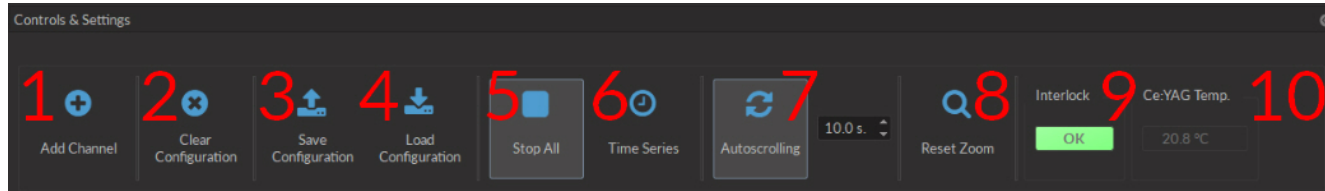

Figure 4.11: Control & Settings

1. The **Add channel** button (Fig. 4.11) opens the **Channel Configuration** window 4.2. See section 4.1.1 for more details.
2. The **Clear Configuration** button (Fig. 4.11) clears all configuration channels. Cleared channels cannot be recovered unless previously saved.
3. The **Save configuration** button saves all currently configured channels in **.doric** format.
4. The **Load configuration** button loads a file in **.doric** format that contains a previously saved set of configured channels.
5. The **Start All** button (Fig. 4.11) starts all currently configured channels.
6. The **Time Series** button opens the **Time Series** window. This tool allows all channels to share the same timing.

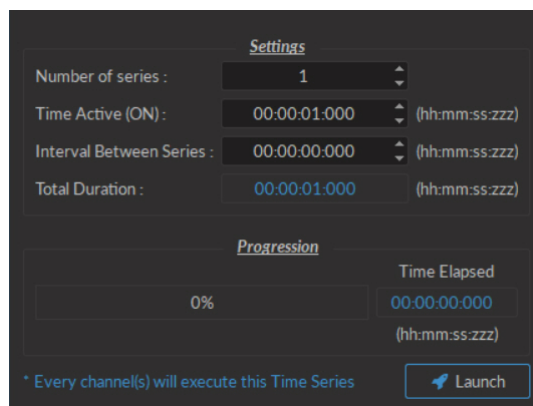

Figure 4.12: Control & Settings, Time Series Window

- The **Number of series** (Fig 4.12) sets the number of times that the sequence will be repeated, with a minimum of 1.
  - The **Time Active** sets the duration of each series in hh:mm:ss:zzz format. If the **Time series** is used in combination with a sequence, the **Time Active** should be greater than the sequence **Total Time** If the **Time Active** is shorter, the sequence will be stopped after the **Time Active**.
  - The **Interval between series** sets the duration between each series in hh:mm:ss:zzz format.
  - The **Total Duration** displays the total duration of the sequence in hh:mm:ss:zzz format.
  - The **Progression** bar displays the progression of the sequence in %, while the **Time Elapsed** counter displays the progression in hh:mm:ss:zzz format.
  - The **Launch** button starts the sequence.
7. The **Autoscrolling** button activates the autoscroll function. When active, the **Graph** in the **Acquisition View** will follow a section as wide as the time defined beside the button.

8. The **Reset Zoom** button resets the axes in the **Graph** to their standard values.
9. The **Interlock** indicator displays OK when the interlock is correctly connected, and DISCONNECTED when disconnected.
10. The **Ce:YAG Temp** indicator displays the temperature of the *Ce:YAG source* in real time. This indicator will only appear when a *Ce:YAG driver* is connected to the computer. Should the temperature be too high the temperature will appear in **red**. Should the temperature be too low, the temperature will appear in **blue**.

### 4.1.3 Experiment View

The **Experiment View** box is used to display information related to the usage of each channel. This section allows limited control of the light source while it is active.

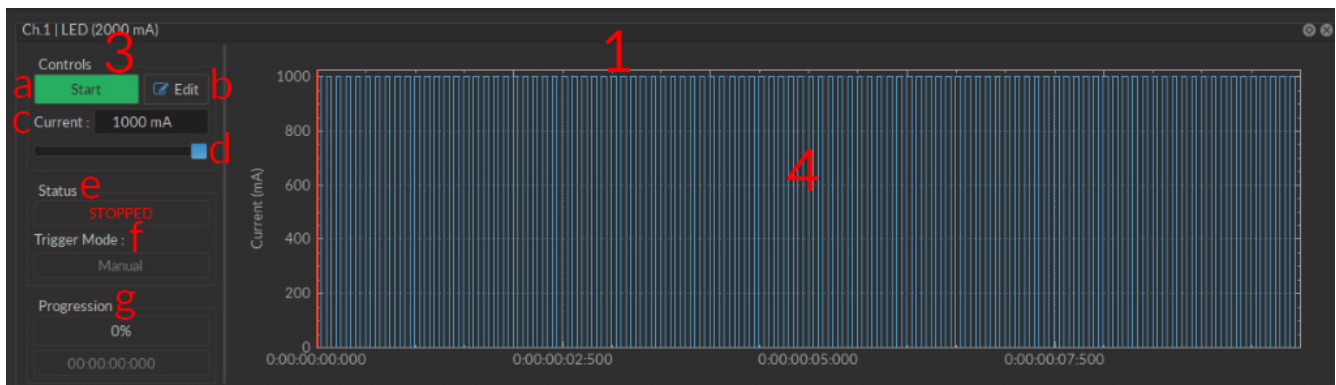

Figure 4.13: Experiment View, Light Source Channel

1. The **Light Source Channel** box (Fig. 4.13) contains all elements related to a single light source channel.
2. The **Scope Channel** box (Fig. 4.14) is used to control and configure an active **Scope**.

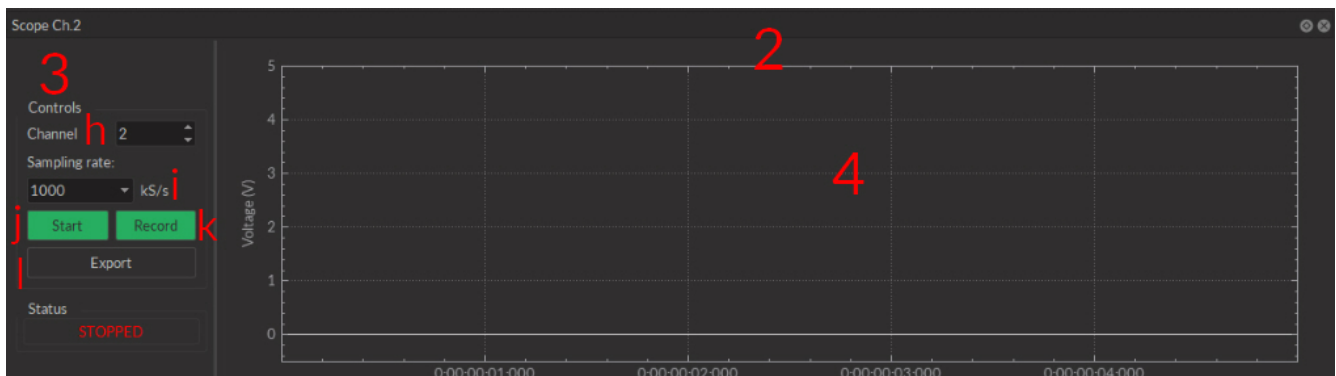















Figure 4.14: Experiment View, Scope Channel

3. The **Controls View** displays all elements to control/configure the channel.
  - a) The **Start/Stop** button activates/deactivates the light source connected to the **Light Source Channel**.
  - b) The **Edit** button opens the **Channel configuration** window to edit the pulse sequence. This button is only accessible when the channel is deactivated.
  - c) The **Current Box** box allows the current to be changed exactly (in mA).
  - d) The **Current Slider** allows the light source current to be adjusted.
  - e) The **Status** box displays the status of the channel (**Light source** or **Scope**). The **Status** will display **RUNNING...** when active and **STOPPED** when deactivated.

- f) The **Trigger Mode** of the light source is displayed in this box.
  - g) The **Progression** box displays the progression of the pulse sequence. The advancement of the sequence is displayed % on the **Progression bar**, and in hh:mm:ss:zzz format on the **Time Elapsed** box.
  - h) The **Channel** drop-down list is used to choose the channel used as a scope.
  - i) The **Sampling Rate** drop-down list allows the selection of the rate (in kilosamples per second) at which measurements are taken.
  - j) The **Start** scope channel button activates a live measurement sequence. Important measurements should not be made as a live measurement, as these only conserve a small amount (60 s) of data.
  - k) The **Record** scope channel button starts a recorded measurement sequence.
  - l) The **Export** scope channel button allows the recording of a live measurement sequence on the scope.
4. The **Graph View** displays either a preview of the pulse sequence for **Light Source Channels** or the received signal for the **Scope Channel**.

## Specifications

Table 5.1: Typical Connectorized LED Output Power vs Optical Fiber Core Diameter

LED	TYPICAL OUTPUT POWER @1000 mA (mW) <sup>1</sup>					Overdrive @2000 mA (pulsed)
	Central Wavelength (nm)	Bandwidth FWHM (nm)	Core 200 $\mu\text{m}$ 0.53 NA	Core 400 $\mu\text{m}$ 0.53 NA	Core 960 $\mu\text{m}$ 0.63 NA	
	365	~12	6.0	23	100	1
	385	~12	6.0	23	100	1
	405	~15	5.0	23	100	1
	420	~15	5.5	23	100	1
	450	~25	8.0	23	100	x1.7
	465	~25	7.5	23	100	x1.7
	505	~30	3.0	12	50	x1.6
	515	~40	3.0	9.5	40	x1.5
	560	~100	2.0	8.5	40	-
	595	~20	2.0	8.5	40	x1.2
	625	~20	3.5	14	70	x1.6
	635	~20	6.5	25	100	x1.6
	850	~35	6.0	22	40	-
	940	~35	2.0	10	40	-
5500K	-	-	4.5	17	80	-

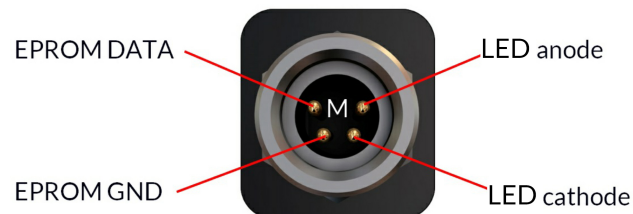

Figure 5.1: M8 Male Pinout (CLEED)

<sup>1</sup>All power values taken at a maximum current of 1000 mA, except for 365, 385, 405 and 420 nm LEDs (500 mA).<sup>2</sup>For all operation modes, except the internal complex mode

Table 5.2: General specifications for LED Drivers

SPECIFICATION	VALUE	NOTE
Power supply	110 - 240 VAC; 50 - 60 Hz	Power supply adapter included
DC power supply	12 VDC	20 W (1-ch, 2-ch), 60 W (4-ch)
Mass		
1-channel model	580 g (1.28 lbs)	
2-channel model	757 g (1.67 lbs)	
4-channel model	1155 g (2.55 lbs)	
Dimensions (L x H x D)		
1-channel model	17,5 cm x 5,0 cm x 10,5 cm	Including connectors
2-channel model	23,4 cm x 5,0 cm x 10,5 cm	Including connectors
4-channel model	3,5 cm x 5,0 cm x 10,5 cm	Including connectors
TTL input voltage	0 to +5 V	Hi Level > 2.8 V; Low Level < 2.3 V
Analog input voltage	400 mA/V light source current 40 mA/V light source current	Normal Mode 2000 mA LED Driver Low current mode (*)
Analog input voltage range	Min: 0.1 V Max: 5 V	40 to 2000 mA 4 to 200 mA (low-current mode (**))
BNC output voltage	0.0025 V/mA	
Maximum output current range	200, 2000 mA	
Maximum forward voltage to LED	7 V	
Minimum output current	40 mA 4 mA	CW, Normal Mode CW, Low current mode (*)
Display current accuracy	2% @ maximum rated current	Error increases at lower current.
Current adjustment steps	1 mA	
Rise/Fall time	< 10 $\mu$ s	Typical
Modulation minimum frequency	0.01 Hz <sup>2</sup>	Internal complex mode : 0.000054 Hz
Modulation maximum frequency	50 kHz	-3 dB attenuation
Minimum ON or OFF time	0.005 ms <sup>2</sup>	Internal complex mode : 2 ms
Maximum ON or OFF time	100 s <sup>2</sup>	Internal complex mode : 5 h
Maximum number of pulses per sequence	16.68 millions <sup>2</sup>	Internal complex mode : 65 535
Maximum number of sequences	4.2 billions <sup>2</sup>	Internal complex mode : 65 535
Minimum step increments	39 $\mu$ sec <sup>2</sup>	Internal complex mode only
Number of steps per period	128 <sup>2</sup>	Internal complex mode only
Scope acquisition speed	10 kS/s	Single channel

Table 5.3: General Specifications for Connectorized LEDs

SPECIFICATION	VALUE	NOTE
Input Current	Min: 0 mA - Max: 1000 mA	Recommended 700 mA
Forward Voltage	3.0 - 4 V Typical	
Dimensions	63 x 59 x 21 mm <sup>3</sup>	Without cable, with baseplate
Mass	~100 g	
CLED cable connector	M8-4pins - Male	See Fig. 5.1
Output NA	0,55	NA of up to 0.63 NA will slightly increase power;
Output Optical Fiber Core Diameter	< 960 $\mu$ m	Power scales up to this core diameter
Maximum Output Power	See Datasheet	Tested with 1 mm diameter core, 0.5 NA optical fiber

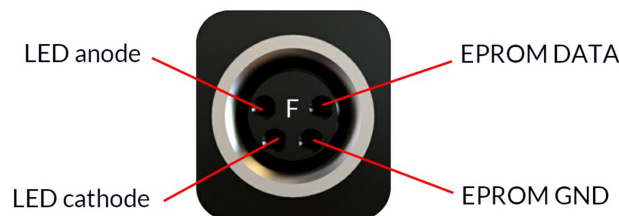

Figure 5.2: M8 Female Pinout (LED Driver)

Table 5.4: *Recommended Environmental specifications*

<b>SPECIFICATION</b>	<b>OPERATION</b>	<b>STORAGE</b>
Use	Indoor	Indoor
Temperature	20°C to 30°C	-20°C to +60°C
Humidity	40-60 % RH, non condensing	40-60 % RH, non condensing



## Annex 1: Safety features

### 6.1 Activation Safety Features

The drivers for all Doric Lenses light sources come with a number of safety features. These are built into the driver circuits, as shown in the block diagram (Fig. 6.1).

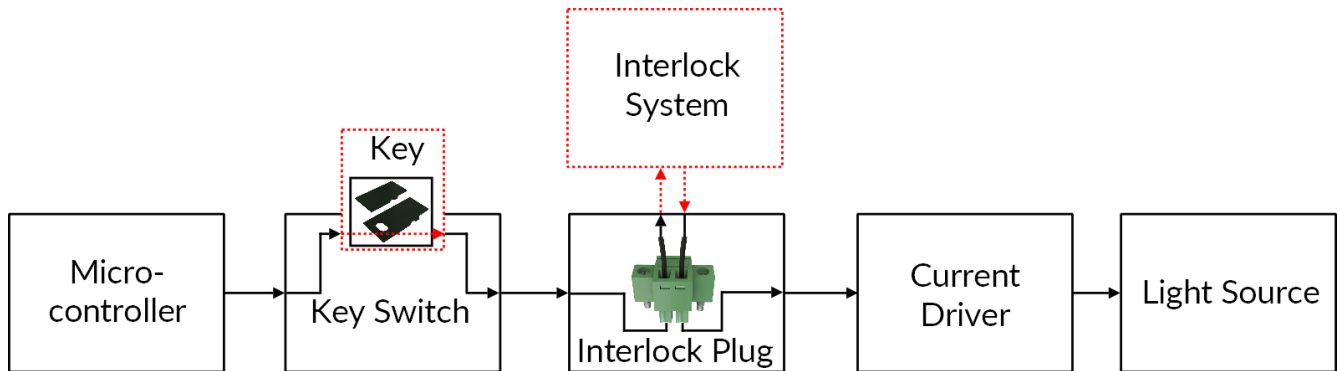
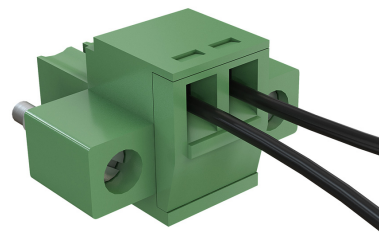

Figure 6.1: Safety feature block diagram

- The **Micro-controller**, **Key Switch**, **Interlock Plug** and **Current Driver** are connected in series. This means that if any single safety feature is not properly in place, the light source cannot be activated.
- The **Micro-controller** is used to control the light source driver.



(a) Key Switch



(b) Interlock Plug

Figure 6.2: Safety Feature Elements

- The **Key Switch** (Safety feature 1) (Fig. 6.2a), located on the left side of the driver, is required to activate any light source. If removed, no data can be sent from the micro-controller to the **Current Driver**.
- The **Interlock plug** (Safety feature 2) (Fig. 6.2b) is used to integrate the driver into an **Interlock Circuit**.

- The **Interlock Plug** comes with a small wire short-circuiting it. This wire must be removed before integrating it into an **Interlock Circuit**.
- Connect the **Interlock circuit** in series with the **Interlock Plug** so the circuit may function properly.
- The **Current Driver** sends current to any connected light source. If the **Key** is absent or the **Interlock Plug** has an open circuit, it cannot receive signals from the micro-controller, preventing it from sending out current.

## 6.2 Emission Indicator

For light sources emitting invisible laser radiation, a dedicated LED indicator is ON when the driver is outputting an electrical current. When the driver is outputting current, the light source will emit light from the aperture.

## Support

### 7.1 Maintenance

The product does not require any maintenance. Do not open the enclosure. Contact Doric Lenses for return instructions if the unit does not work properly and needs to be repaired.

### 7.2 Warranty

This product is under warranty for a period of 12 months. Contact Doric Lenses for return instructions. This warranty will not be applicable if the unit is damaged or needs to be repaired as a result of improper use or operation outside the conditions stated in this manual. For more information, see our [Website](#).

### 7.3 Contact us

For any questions or comments, do not hesitate to contact us by:

**Phone** 1-418-877-5600

**Email** [sales@doriclenses.com](mailto:sales@doriclenses.com)



© 2019 DORIC LENSES INC

357 rue Franquet - Quebec, (Quebec)  
G1P 4N7, Canada

Phone: 1-418-877-5600 - Fax: 1-418-877-1008

[www.doriclenses.com](http://www.doriclenses.com)