

NX

NX GOLF TROLLEY USER GUIDE

ORIGINAL VERSION

EN **ENGLISH**



**PLEASE READ THE USER MANUAL CAREFULLY
BEFORE ASSEMBLING YOUR GOLF TROLLEY
FOR THE FIRST TIME**

CONTENTS

Trolley usage & safety	1	Powering up the trolley	12
Battery & charger safety (1)	2	Trolley control & display	13
Battery & charger safety (2)	3	VRAP distance control setting	14
Locating & recording trolley serial number	4	Battery capacity level	15
Lithium battery charging	5	USB charging port	16
Lithium battery storage	6	Front wheel tracking	17
Attaching the front wheel	7	Accessory fitting	18
Rear wheel fitting & inverting	8	Trolley & battery maintenance	19
Unfolding the NX trolley	9		
Bag supports & adjustment	10		
Battery fitment	11		

TROLLEY USAGE & SAFETY

Ensure that the battery is disconnected before folding, storage and transportation of the trolley.

The NX trolleys are designed for the transportation of golf bags and the contents within. Using the trolley for any other purpose may cause damage to the trolley and cause harm to the user.

The trolley is not designed for the transportation of people.

Do not use the trolley to support your body weight when climbing or descending hills.

Submerging the trolley in water will cause damage to the trolley & battery pack.

Do not operate the trolley whilst under the influence of drugs or excessive amounts of alcohol.

Do not store your trolley outside.

The NX trolley is built with golf course conditions in mind, including rain and cold temperatures. Try to minimise exposure to heavy rain as much as possible with an umbrella during heavy rainfall.

Wipe excess water from the trolley prior to storage.

Never use a jet washer to clean your trolley.

To prevent water damage, clean your trolley with a damp cloth and dry afterwards.

Please be aware that certain moisture, temperature and humidity conditions can result in localised misting within the display screen. This will not affect the trolley functionality, nor cause any damage and will return to normal when adverse conditions subside.

This trolley can be used by children aged from 8 years and above or by persons with reduced physical, sensory or mental capabilities or lack of experience and knowledge if they have been given supervision or instruction concerning use of the appliance in a safe way and understand the hazards involved.

Cleaning and user maintenance shall not be made by children without supervision

Rated load: Golf bag 20kg.

BATTERY & CHARGER SAFETY

To Prevent the risk of injury from burns, fire or explosion:

Read the instructions carefully before use.

If your battery / charger product is immersed in water or is suspected of suffering water ingress, dispose of it immediately and replace.

Only use the correct charger supplied by Wizza Ltd (Or authorised distributor), and ensure that the battery is charged every three months.

Never short circuit or reverse the battery connections.

Use only the correct batteries /chargers originally supplied with your product or replacements originating from Wizza Ltd.

Never use batteries that are not an original manufacturers equipment.

Never put the batteries / chargers into fire.

Never disassemble the battery /charger.

Never expose the battery to temperature above 140 F

Never place in a wet or corrosive surrounding.

The internal fuse can only be replaced by the manufacturer.

BATTERY & CHARGER SAFETY

Warning:

The following circumstances will not be covered under warranty:

- Where the battery / charger, intentionally or unintentionally is either damaged or destroyed.
- Where the battery / charger is used in either the incorrect golf trolley model or for any other purpose.
- Where the battery / charger serial number is altered or lost.
- Where the battery / charger casing is in anyway tampered with.

If your battery / charger product is immersed in water or is suspected of suffering water ingress, dispose of it immediately and replace.

If your battery has suffered impact damage dispose of it immediately and replace.

TROLLEY SERIAL NUMBER

Locating & Recording Your Serial Number

The serial number for the NX trolley is located where the battery sits on the frame.

A copy of the serial number can also be found on the outside of the box that your trolley was delivered in.

Please keep a record of this serial number as well as a copy of your proof of purchase.

This information will be required in the event of a warranty claim.

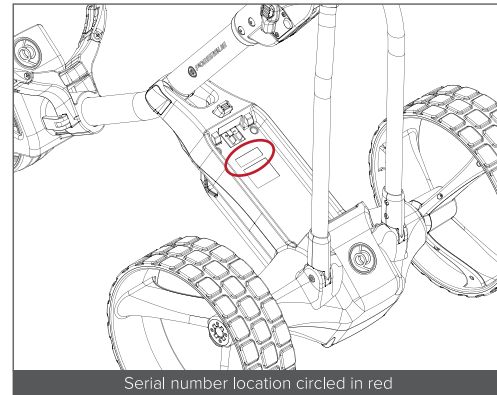

RECORD YOUR SERIAL NUMBER HERE:

T	P	B												
---	---	---	--	--	--	--	--	--	--	--	--	--	--	--

LITHIUM BATTERY CHARGING

Charging your Lithium Battery

1. Unplug the Lithium battery from the trolley by pulling the grey connection block away from the trolley. This will expose the charging connector. It's advisable to completely remove the battery from the trolley to make charging easier.
2. Plug the battery charger into your mains supply
3. Plug the charging cable into the battery connector block.
Please note the polarity of the connection (Red to red, black to black)
4. When the LED charging indicator has turned green, the battery is fully charged and ready to be used.



Red light - Battery charging



Green light - Battery is fully charged

5. Average charge time is 4 - 6 hours. This may vary depending on course condition.
6. Once the charging cycle is complete, disconnect the charger from the mains power supply.
7. Finally disconnect the charger from the battery

Caring for your Lithium Battery

Avoid exposure to excessive water, and do not clean your trolley whilst the battery is still mounted.

Dropping the battery is likely to cause internal damage to the cells and battery management system.

Impact damage is not covered by your manufacturers warranty.

Batteries showing signs of impact damage should be disposed of immediately and replaced.

LITHIUM BATTERY STORAGE

Storing your NX Lithium battery for extended periods of time

If your Lithium battery is not going to be used for lengthy periods of time (3+ months at a time) it is advised to store the battery at 50% capacity.

To do this simply use the battery for a round of golf as usual and charge it for 2 hours at the end of the round.

Before the first round after the extended break, fully recharge your battery.

We recognise that sometimes long absences from golfing are not always planned, however when it is likely that you will not be using your battery for a period of time it is good practice to follow these steps to extend the life of your Lithium battery.

Please ensure that the charger is ALWAYS disconnected from the battery after charging.

Battery Management System (BMS)

The NX Lithium battery is fitted with a battery management system (BMS) to protect the battery from abuse, high currents, deep discharge and overcharge.

When the battery is delivered there may be no output as the BMS is designed to maximize safety whilst shipping. Please ensure that the battery is fully charged prior to connecting it to your trolley as this will activate the BMS and effectively 'switch-on' the battery.

From time to time, at deep discharge or long term storage the BMS may switch-off the battery. A full battery charge will rectify this problem.

If for any reason the voltage on the battery falls below the low battery warning on the trolley, the BMS may disable the battery to protect it. If this occurs, please recharge the battery fully.

ATTACHING THE FRONT WHEEL

Attaching the front wheel assembly to your NX trolley

When first unboxing your new NX trolley, you'll need to fit the quick release front wheel assembly to the frame.

Once the front wheel has been fitted to the frame, it can remain on there for the duration of the NX trolley's lifespan. The front wheel assembly can also be removed to make cleaning this area easier.

1. Insert the front wheel assembly onto the base of the trolley frame, please note the direction of the assembly with the bag support area facing upwards.
2. Insert the securing lever through the frame and front wheel assembly
3. Fasten the securing lever & nut provided.

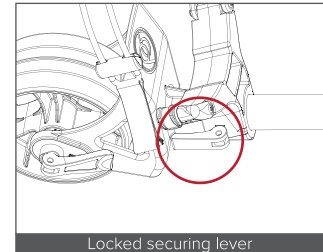
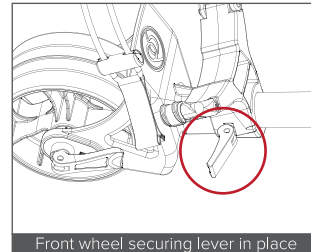
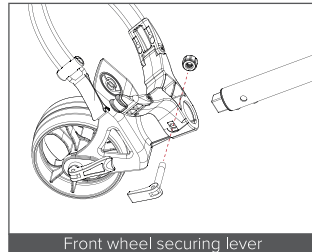
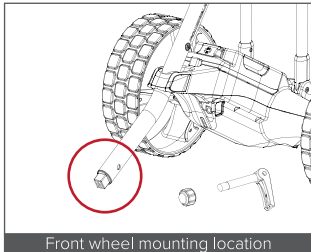

ATTACHING THE REAR WHEELS

Attaching the rear wheels to the NX trolley

The NX does not have specific left and right hand wheels.

1. Push and hold down the release button on the centre of the wheel.
2. Slide the wheel onto the axle and ensure that the drive pin is engaged with the wheel.
3. Once in position, release the button and pull the wheel outwards slightly to lock into place.

The NX can be used as a push trolley should you forget to charge your battery.

To set the wheels to free-wheel mode, simply release the wheel from the drive pin on the axle. The wheel will click into the freewheel groove about 1cm away from the drive-mode setting.

The wheels can be inverted to reduce the trolley width for transportation and storage.

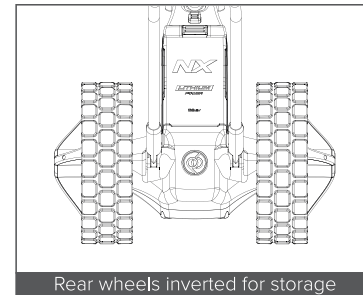
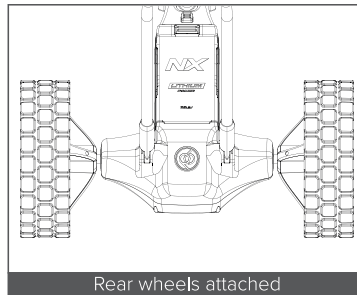
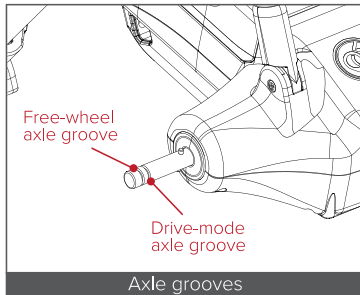

UNFOLDING YOUR NX TROLLEY

Unfolding your trolley

To unfold your NX trolley, make sure the rear wheels are not in the inverted position.

To unfold the frame, press the grey locking button and lift the handle until the middle hinge lock clicks into place. Your trolley is now ready to use.

To fold the trolley down for storage simple reverse the unfolding process.

To save extra room when storing your NX trolley, the wheels can be removed and re-attached inverted.

We recommend completely removing the battery from the trolley before folding for transport.

Please ensure no dirt or debris becomes trapped inside the folding mechanism of the NX trolley.

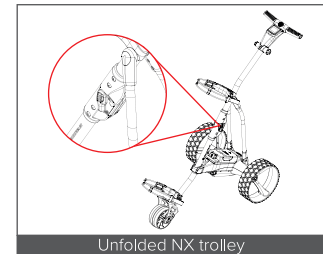
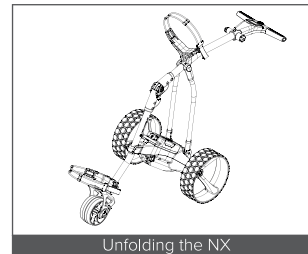
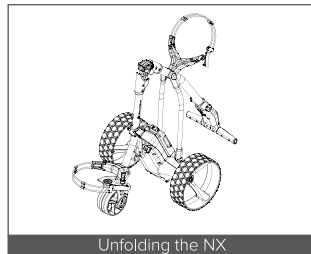
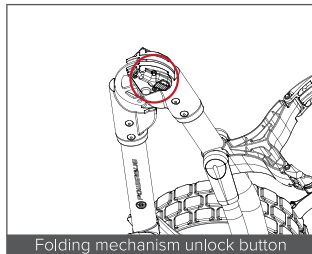

BAG SUPPORTS & ADJUSTMENT

Mounting your golf bag to the NX trolley

The NX trolley is compatible with all types of golf bag from pencil size up to tour size.

To mount your bag to the NX, ensure the bag straps are clear from the bag mounting areas and place your bag onto the trolley.

Secure the bag by using the elasticated bag straps. Both the upper and lower supports secure the bag with a rounded tab and hook system.

Adjusting the bag support straps

1. Unhook the bag support elastic from the mounting tab.
2. Move the mounting tab to the desired position (Ensuring that both sides of the elastic strap are equal)
3. Hook the bag support elastic back into the mounting tab.

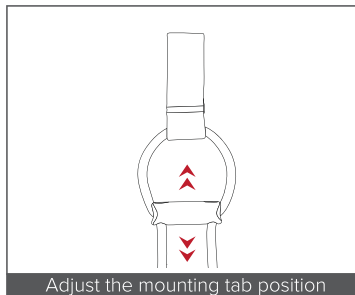
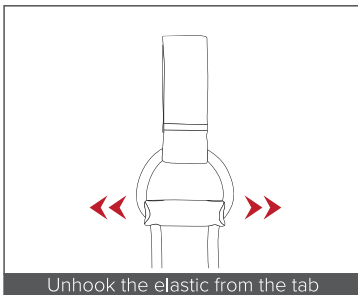

BATTERY FITMENT

Fitting the battery

The NX battery clips onto the battery tray area with ease.

To remove the battery, ensure the power block is in the 'off' position and press the battery release button.

For more information about the power block positions, please see page 8.

We recommend completely removing the battery from the trolley before folding for transport.

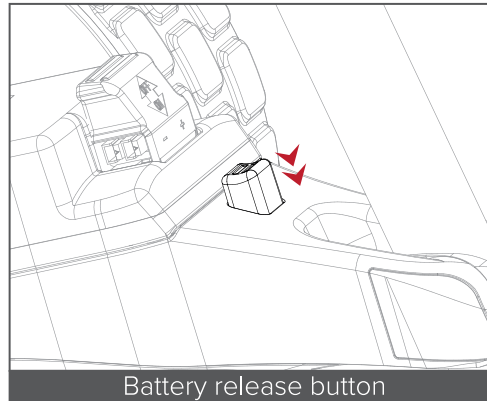
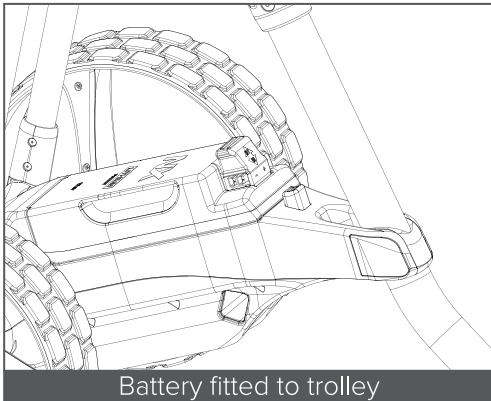

POWERING UP THE TROLLEY

Powering up the trolley

The NX battery charging block also acts as an on/off switch for the trolley.

After inserting the battery into the frame of the NX, pushing this block down will connect the battery to the trolley and power the trolley up.

It is extremely important that after your round of golf the battery is disconnected by reversing the above steps.

To turn the trolley off, pull the power block out. The battery can then also be removed from the trolley for charging.

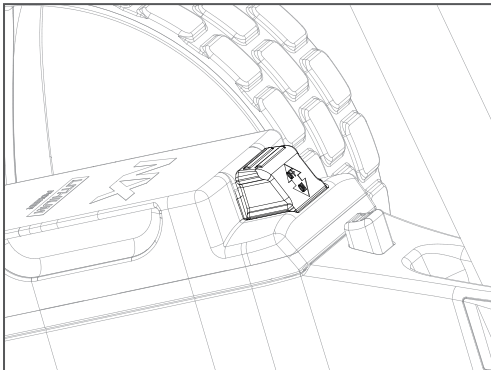

Trolley power block 'on' position

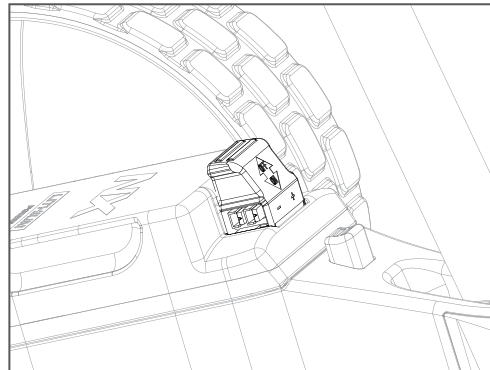

Trolley power block 'off' position

TROLLEY CONTROL & DISPLAY

Speed selection

To select the speed of the trolley, turn the speed control button on the handle in a clockwise or anti-clockwise direction. Speed selection varies from 1 to 9 in increments of 0.5.

Starting and stopping the NX trolley

Push down the speed control button to activate the NX trolley.

Push the button once more to stop the trolley.

The pre-set speed will stay the same unless adjusted, allowing you to take your shot and resume walking at your normal pace.

Speed settings can also be changed whilst the trolley is in operation and travelling along the fairway.

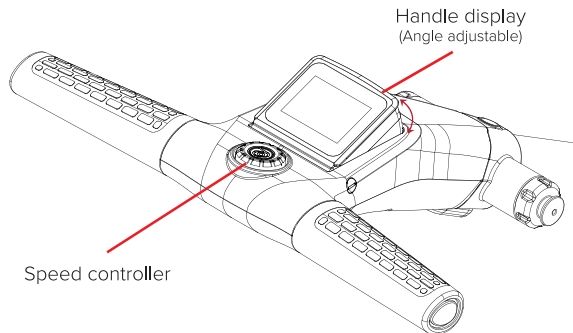

VRAP DISTANCE CONTROL

VRAP settings (Variable Run And Park)

This trolley features adjustable distance control which will allow you to send your to run and park for a pre-set distance.

1. Pre-select the speed that you wish your trolley to set off at. (1 - 9)
2. Hold down the speed control button for 3 seconds, the number '05' will flash on the display. There are 10 different settings for the distance, see the chart below for each options distance in yards.
3. Turn the button clockwise to increase and anti-clockwise to decrease to your preferred distance.
4. Press the on/off button to set the trolley in motion. While the trolley is powered using VRAP, the remaining distance of travel will count down on the display. (i.e 15, 10, 05)
5. The trolley can be stopped before the distance is complete by pressing the button again.

VRAP distance settings

05	10	15	20	25	30	35	40	45	50
5 Yards	10 Yards	15 Yards	20 Yards	25 Yards	30 Yards	35 Yards	40 Yards	45 Yards	50 Yards

BATTERY CAPACITY LEVEL

Battery meter

The NX displays a live battery level which provides an indication of remaining battery capacity. The number of illuminated bars will decrease as the battery capacity reduces.

A fully charged battery will show from left to right - two short red bars, two medium orange bars and two larger green bars.

The trolley is designed to protect your battery from being fully discharged, should your battery capacity drop too low the trolley will cut the power to the motor.

Please be aware that certain moisture, temperature and humidity conditions can result in localised misting within the display screen. This will not affect the trolley functionality, nor cause any damage and will return to normal when adverse conditions subside.

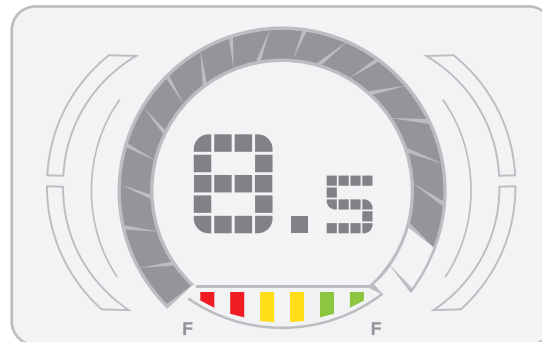

USB CHARGING PORT

USB Charging Port

The NX trolley features a USB charging port underneath the handle designed to charge USB powered devices during your round such as your mobile phone or GPS device.

Remove the covering cap and plug a USB cable into the charging port located on the underside of the handle. The device will continue charging while the cable is attached and the battery is connected.

The rate of charge will be slower than a mains AC charger and similar to plugging the device into a PC. The USB charger takes power from the main trolley battery and continuous charging will reduce the battery capacity between charges. The trolley is designed to disable the USB port when the battery capacity reaches a preset level.

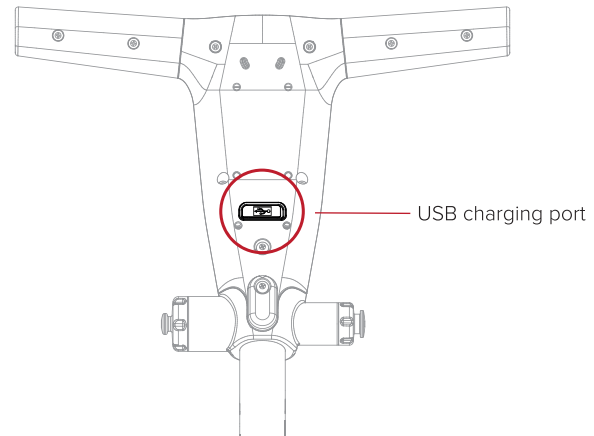

FRONT WHEEL TRACKING

Adjusting the front wheel alignment

In the unlikely event that your trolley is not driving in a straight line, the alignment of the front wheel can be adjusted to rectify the fault. This problem can be caused by a number of factors including a loose front wheel assembly or a loose front wheel adjustment lever.

Front wheel alignment tuning

1. Lift the quick release lever positioned on the front wheel housing and loosen the wheel nut.
2. There are two small metal dials on either side of the housing that are used to realign the wheel.
3. If your trolley is veering to the right, you will need to turn the left hand dial clockwise and the right hand dial anti-clockwise
4. If your trolley is veering to the left, you will need to turn the right hand dial clockwise and the left hand dial anti-clockwise
5. Tighten the wheel nut and push down the lever to lock the wheel back into place

Please note that this process may take some trial and error before a perfect result is achieved.

The directions above are based on positioning yourself in front of the trolley looking at the wheel.

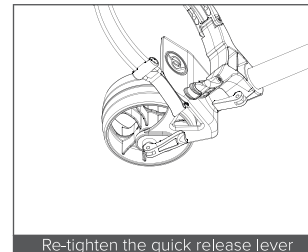
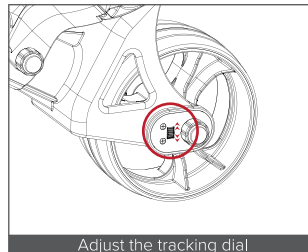
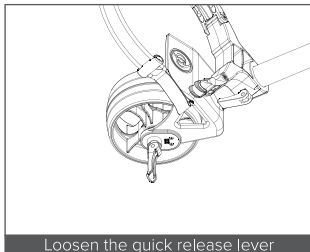

ACCESSORY FITTING

Fitting accessories to the NX trolley

Accessories are not included as standard with the NX trolleys and in most cases are purchased separately.

To fit the Umbrella Holder, Score Card Holder and GPS Holder the end caps will first need to be removed from the accessory mounting points. Please do not discard these covering caps, as they may be required at a later date.

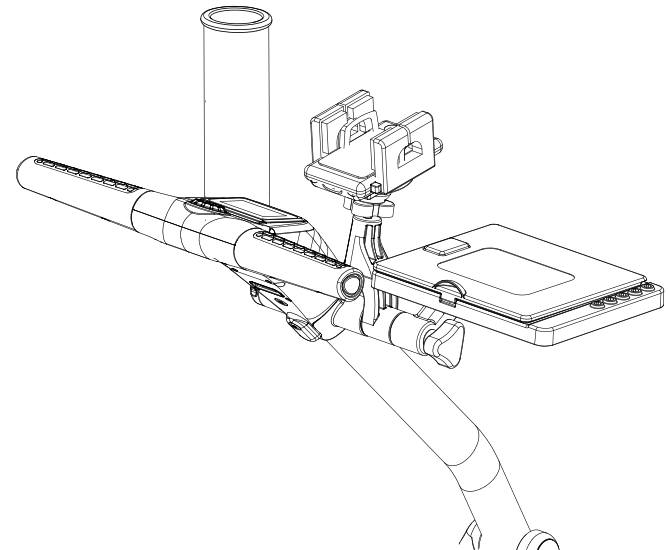
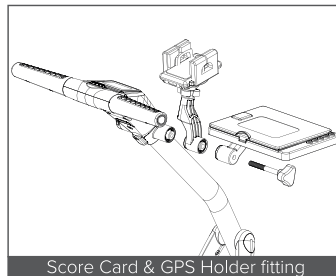
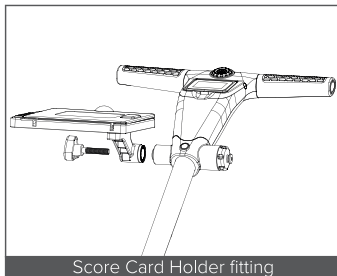
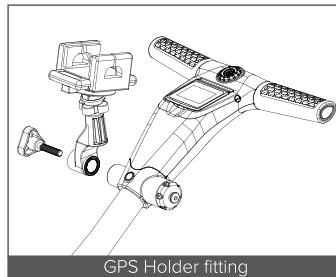
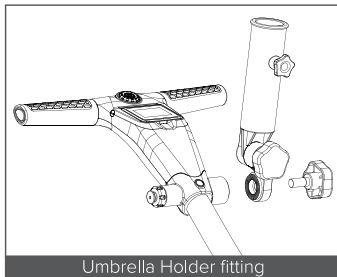

TROLLEY & BATTERY MAINTENANCE

The NX trolley is designed to require almost no maintenance and doesn't require servicing during specified intervals.

To keep your trolley in optimum condition, it is recommended to try and keep it as clean as possible.

Some key areas to keep clean are:

Rear wheels & axle

It's advised to regularly remove the wheels from your trolley and clean the ends of the axles and to ensure there's no obstructions in the wheel mechanism.

Front wheel & housing

The front wheel is designed so it will not clog up with mud during the winter months. It is still advisable to keep this area as clean as possible.

All batteries must be charged as soon as possible after each use. Leaving batteries discharged for long periods of time will affect the battery life.

Please ensure that only batteries supplied with the NX trolley are charged with NX chargers.

The NX Lithium battery charger must not be used to charge any other battery and is designed for use with NX Lithium batteries only.

The battery must be stored and charged on a dry non-carpeted surface and charged at temperatures ranging between 10°C and 30°C. Charging above or below these temperatures is not recommended as it can reduce the battery capacity.



NX:

28.8v D.C 85w IPX4
Battery voltage: 28.8v D.C

Power supply (LC-2323):

Input: AC100 V-240 V; 50 Hz/60 Hz; 85 W; Class II;
Output: 28.8v D.C d.c 2.0a

Manufacturer:

Wizza LTD
Bath Road, Hare Hatch, Reading
Berkshire
RG10 9SB
United Kingdom

H3

