

T1 Install & Operation Manual

Safety

This appliance can be used by children aged from 8 years and above and persons with reduced physical, sensory or mental capabilities or lack of experience and knowledge if they have been given supervision or instruction concerning use of the appliance in a safe way and understand the hazards involved. Children shall not play with the appliance. Cleaning and user maintenance shall not be made by children without supervision.

The unit should be isolated from the electricity supply before removal of any covers. Great care must be employed when working with high pressure carbon dioxide, and in no cases should the maximum operating pressure of 0.4MPa (4 bar) be exceeded.

- The appliance is not suitable for installation in an area where a water jet could be used.
- The appliance has to be placed in a horizontal position

WARNING: Keep ventilation openings in the appliance enclosure or in the built-in structure clear of obstruction.

WARNING: When positioning the appliance, ensure the supply cord is not trapped or damaged.

WARNING: Do not locate multiple portable socket-outlets or portable power supplies at the rear of the appliance.

This appliance is intended to be used in household and similar applications such as:-

- Staff kitchen areas in shops, offices and other working environments
- Farm houses and by clients in hotels, motels and other residential type environments
- Bed and breakfast type environments
- Catering and similar non-retail applications

A-weighted emission sound pressure level is below 70 dB(A)



R290 is a refrigerant-grade propane used on a wide range of commercial refrigeration and air conditioning units. A highly pure propane, it has a low environmental impact and nominal global warming potential (GWP), meaning it possesses no qualities that can destroy the ozone layer. R290 also is the preferred hydrocarbon alternative of the Environmental Protection Agency (EPA), substituting more harmful fluorocarbon refrigerants like R22, R134a, R404a and R502.

Units with R290 can only be maintained and repaired by authorized technicians who are properly trained and certified.

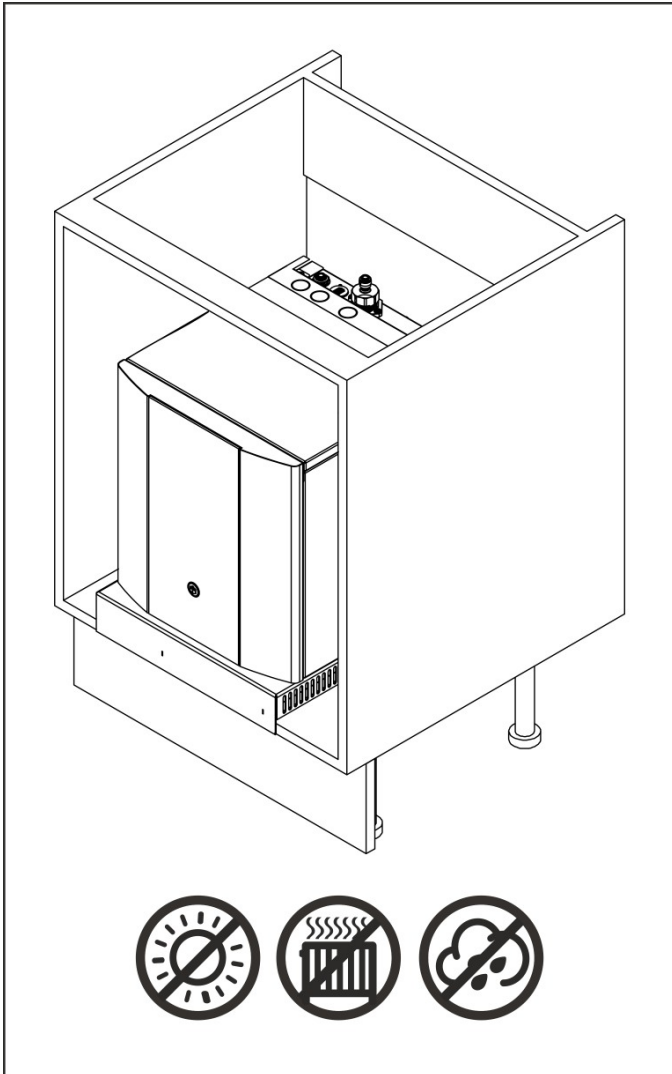

- Always place the dispenser in its vertical position, on a surface which can capably support its weight.
- During use this machine must remain in its upright position.
- Adequate ventilation must be allowed for – we recommend using the supplied ventilation ducting kit.
- Keep the machine away from sunlight, heat and moisture.
- Power and water supply points must be available near the dispenser, and must meet the criteria specified in the 'Specification' section of this manual.
- The environment where this machine is installed must be free of dust and corrosive/explosive gases.

Waste Electrical Products:

- The WEEE symbol indicates that this item contains electronic components which must be collected and disposed of separately.
- Never dispose of electrical waste in general municipal waste. Collect and dispose of such waste separately.
- Make use of the return and collection systems available to you, or your local recycling programme. Contact your local authority or place of purchase to find out what schemes are available.
- Electrical and electronic equipment contains hazardous substances which, when disposed of incorrectly, may leak into the ground. This can contribute to soil and water pollution which is hazardous to human health; and endangers wildlife.
- It is essential that consumers look to re-use or recycle electrical or electronic waste to avoid it going to landfill sites or incineration without treatment.



Specification

COOLING SYSTEM	Stainless steel direct chill coil encased in a solid-block system for instant response cool down action. Ultra efficiency compression system with capillary control. Environmentally friendly R290 refrigerant.
COLD TEMPERATURE	2°C - 11°C.
OUTPUT PER HOUR (ProCore)	50 litres Chilled 50 litres Sparkling
DISPENSE	Quadra Neck Faucet with ergonomically designed and situated light touch sensitive controls.
MAXIMUM RUNNING POWER CONSUMPTION - CHILLED, & SPARKLING	ProCore 0.20kW - 230V
MAXIMUM RUNNING POWER CONSUMPTION - CHILLED & AMBIENT	ProCore 0.14kW - 230V
QUANTITY OF REFRIGERATION GAS	R290a 33g
POWER SUPPLY	220V - 240V AC (50 Hz)
WATER CONNECTION	Mains in - 3/4" BSP
CO2 CONNECTION	1/4" Push Fit.
DIMENSIONS	(w x d x h) 320 x 370 x 340mm.
WEIGHT	24Kg
RATED CURRENT - CHILLED & AMBIENT	ProCore 1A
RATED CURRENT - CHILLED, AMBIENT & SPARKLING	ProCore 1.2A
FUSE RATING	5A
MINIMUM TO MAXIMUM INLET WATER PRESSURE	0.05MPa (0.5 bar) - 1.0 MPa (10 bar) Internally regulated to 0.3 MPa (3 bar)
CO2 PRESSURE	0.4MPa (4 Bar) Maximum
MINIMUM TO MAXIMUM AMBIENT ROOM OPERATING TEMPERATURE	5°C - 35°C

Model Overview

Introduction

The T1 epitomises cutting-edge design and innovation with its contoured tap and compact ProCore unit. This is

our most discreet range and will fit into any environment seamlessly.

The ProCore dispenser is a cooler designed to provide chilled and carbonated water. All the materials and components

are tested during the entire production process in order to satisfy all expectations.

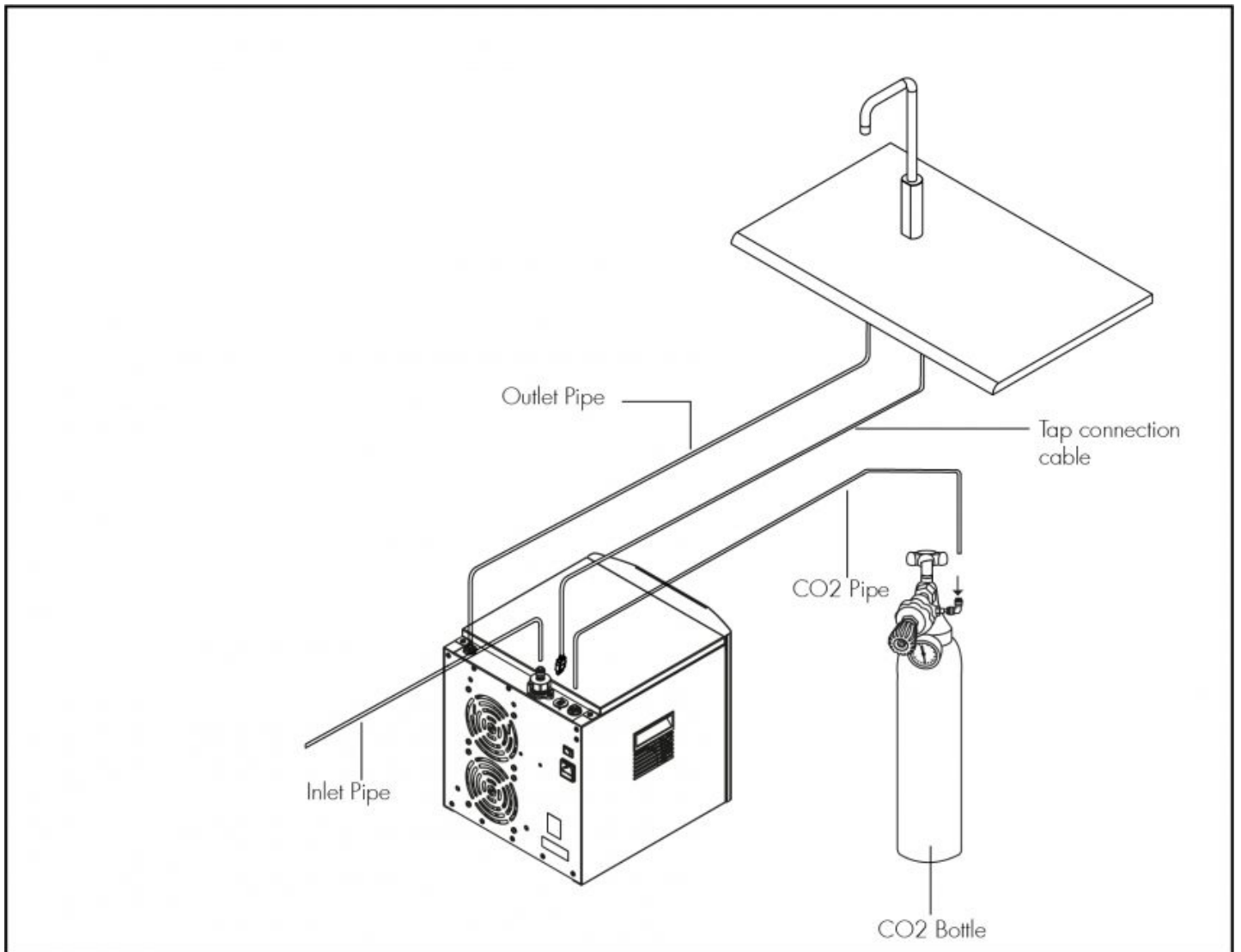

Component/Feature Overview

T1 Tap - Major Components

Contents:

1 no T1 with Control Panel

1 no 1.0m x 6mm Insulated Water Pipe

1 no Connector Cable

1 no Fixings Set

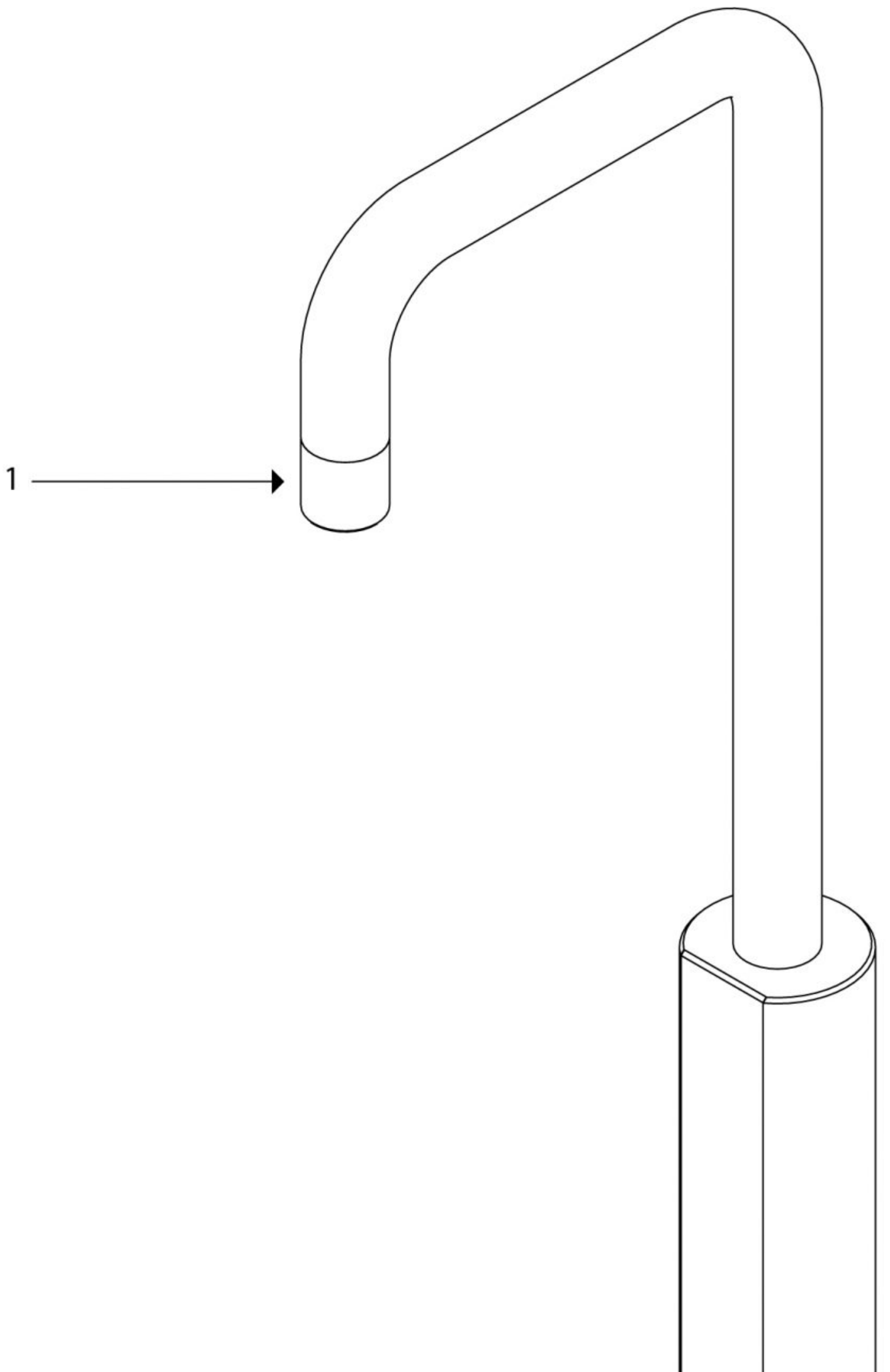

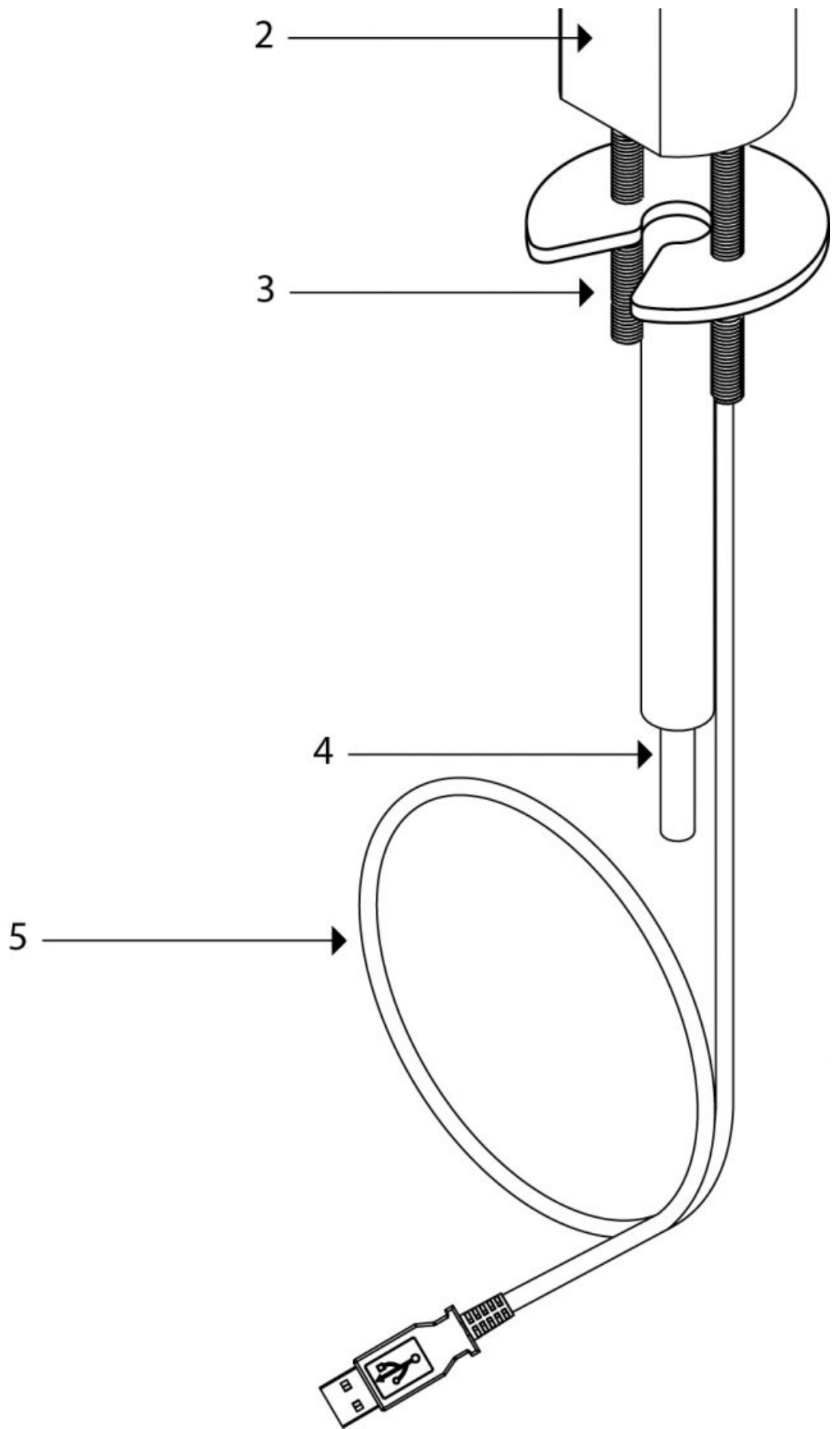

1. Faucet, 2. Capacitive touch display, 3. Fixing Threads and Bracket, 4. Water Outlet Pipe, 5. Connector Cable

ProCore Electronic - Major Components

Contents:

1 no Undercounter Unit

1 no 2.0m Power Cord Set

1 no Co2 Regulator with Gauge & Connection
tube*

1 no ProCore Simple-fit Ventilation Kit

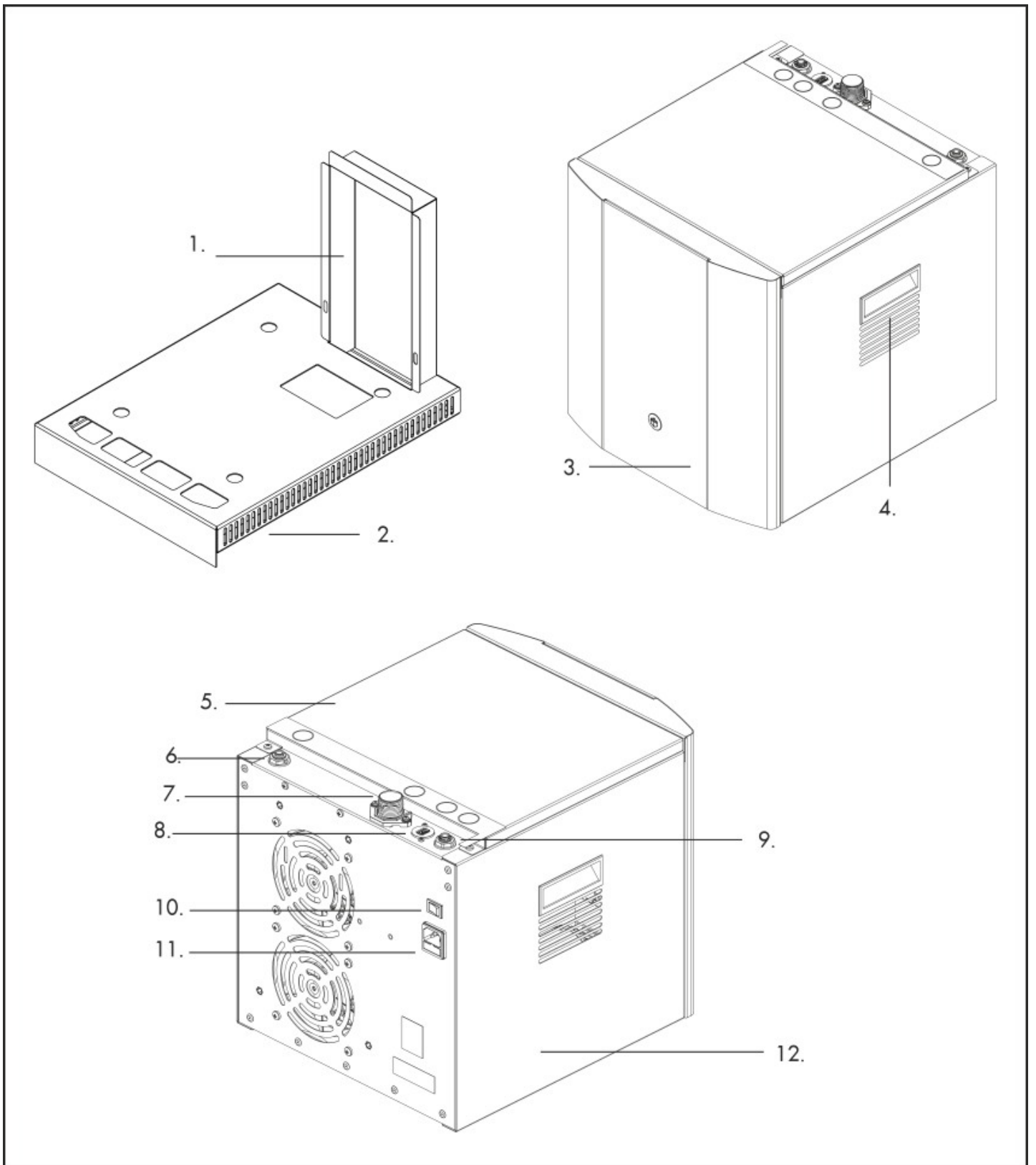

1. ProCore Simple-fit Chimney, 2. ProCore Simple-fit Base, 3. Front Panel, 4. Carry Handle, 5. Top Panel, 6. Water Outlet, 7. Water Inlet, 8. Tap Connection, 9. CO2 Inlet*, 10. On/Off Switch, 11. Power Connection, 12. Side Panel

Please Note:

Mains Installation Kit & Filters are supplied as extra items according to individual ordering requirement.

*Sparkling versions only

Dimensions

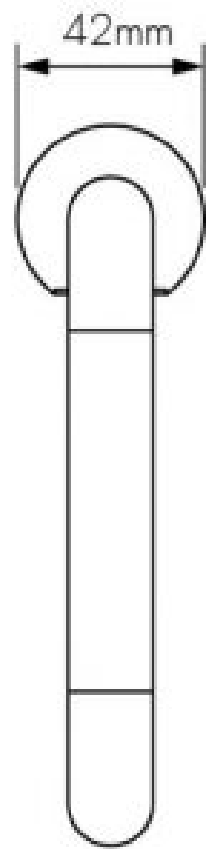
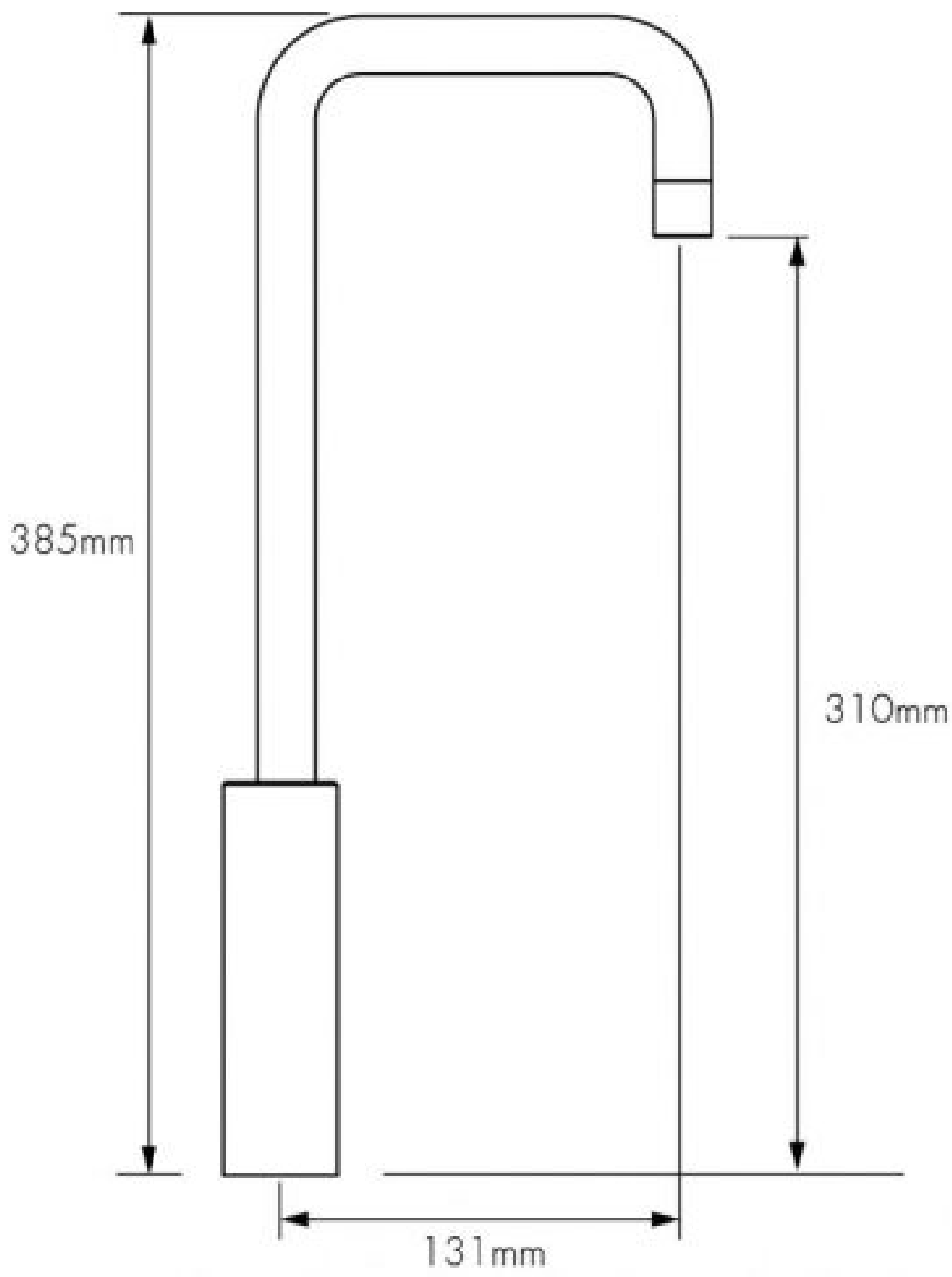

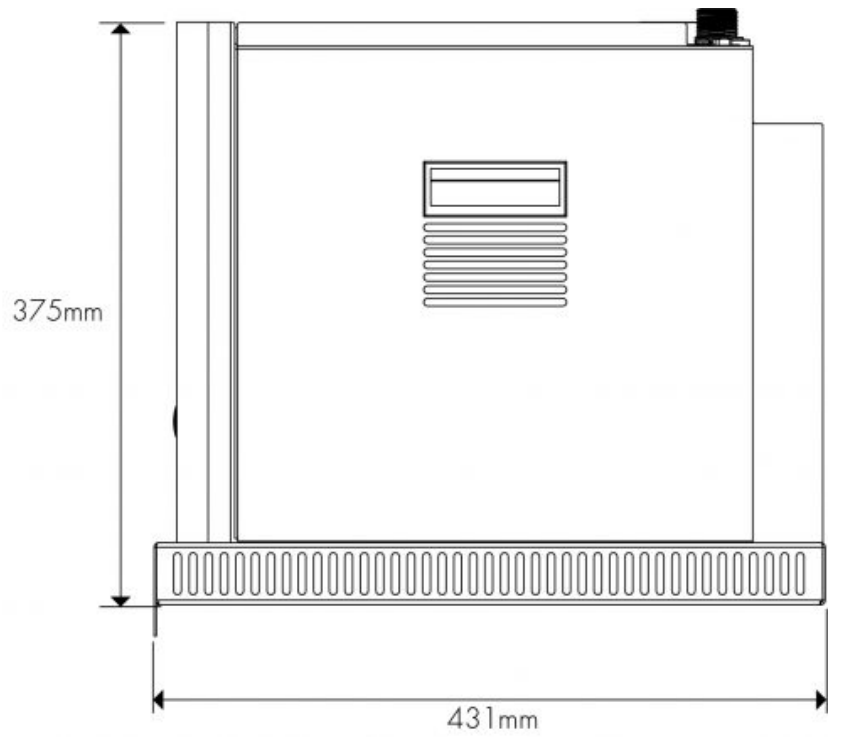
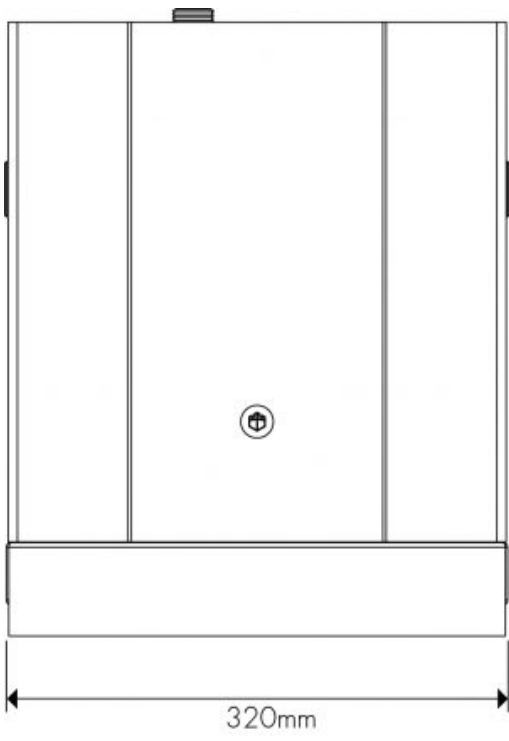

Installation

Installation Requirements

Identify a suitable location for the ProCore unit. It should be positioned within 1.0m of the faucet, and within 2.0m of suitable services connections. Allow enough space to fit the ventilation ducting system.

The ProCore unit must be installed in accordance with the relevant requirements of:

- The appropriate building regulations by application of either The Building Regulations (England and Wales), The Building Regulations (Scotland) or The Building Regulations (Northern Ireland). In territories other than those listed the local regulations in force must be complied with.
- The Water Supply (Water Fittings) Regulations (England, Wales and Northern Ireland) or The Water Byelaws in Scotland.

The unit must not be installed where it is liable to freeze. If the unit is thought to be frozen it must not be switched on. It should be allowed to thaw and must then be thoroughly inspected to ensure it is undamaged.

Service Requirements

- Water: Mains potable water – internally regulated to 0.3MPa (3 bar)
- CO2: Food Grade CO2 to be supplied
- Min mains pressure 0.05MPa (0.5 bar)
- Electricity: 13A supply – Earth Leakage Protected
- Waste Drain Connection

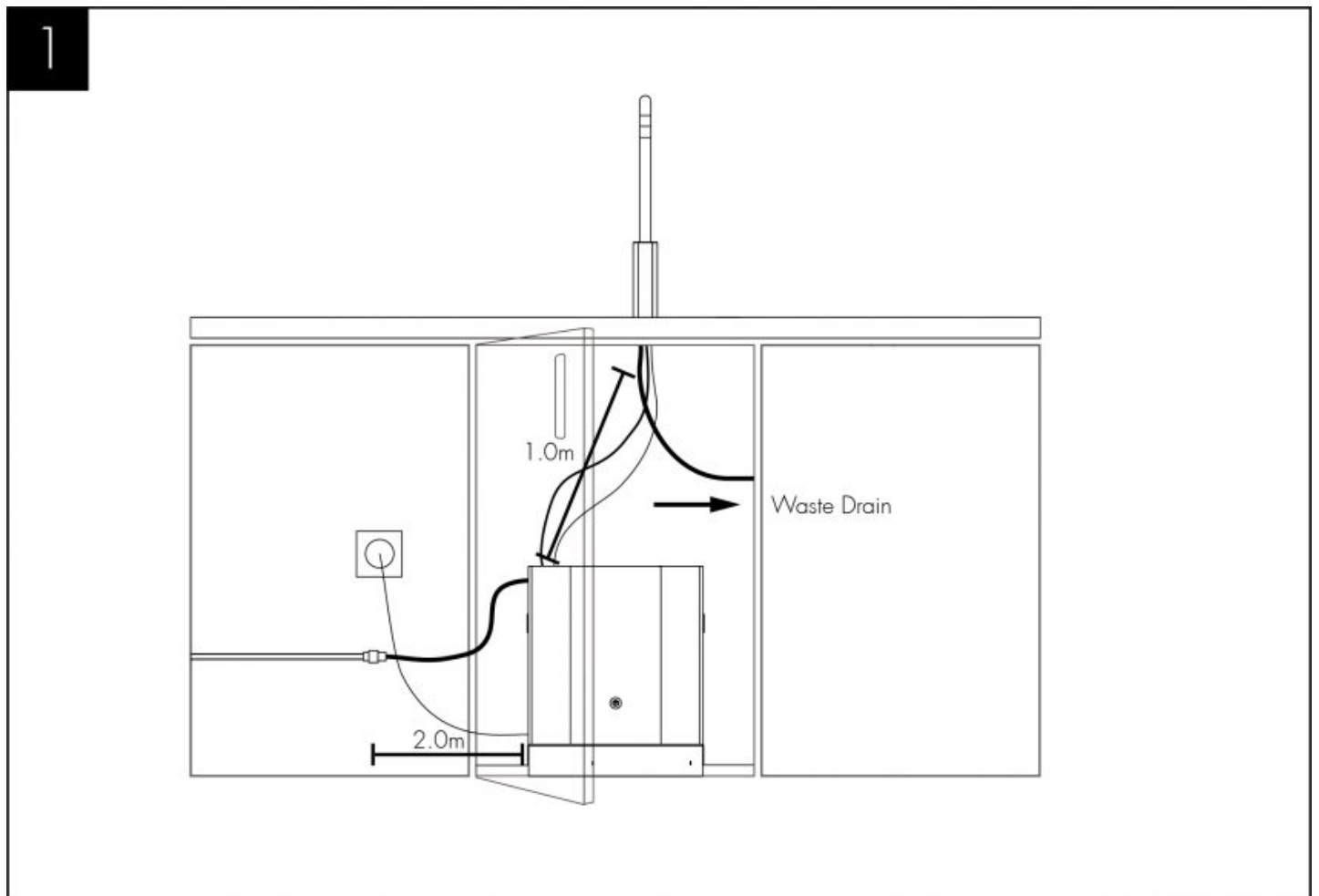

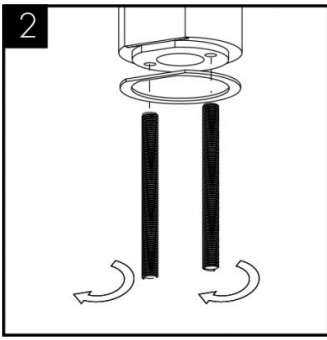

Using the M5 allthreads as provided locate them into the base of the tap and tighten till secure. Fit the gasket on the base of the tap.

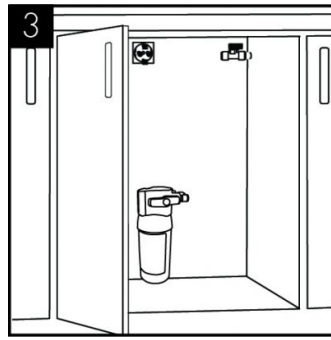

When planning and providing for the connection to the services, always allow for easily accessible service isolator fittings and for the position of an external water filter.

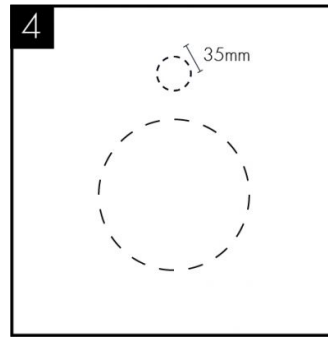

Identify a suitable position for the faucet. Refer to the cut out guide template. Ensure worktop is level to allow system to drain.

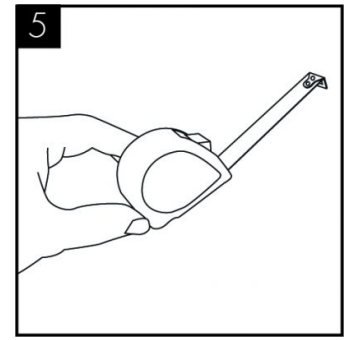

Allow for the space needed for forming the required cut out. Relate the selected position to the underneath of the counter and check for any obstructions.

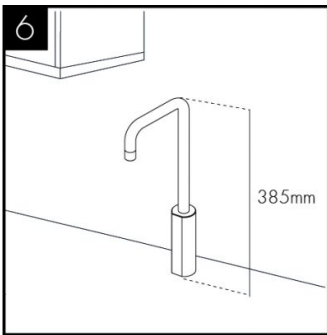

Also allow for the height of the swan neck under any overhanging cupboard/shelf.

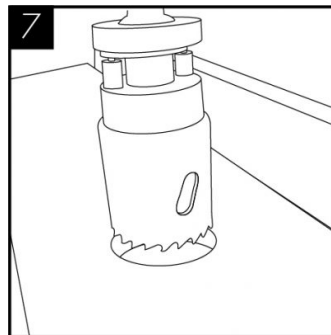

Carefully form the needed hole, using the correct type of cutter for the work surface material. Observe all local occupational health and safety requirements.

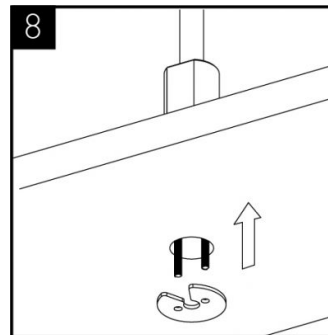

Allow sufficient space for fitting the worktop fixing bracket.

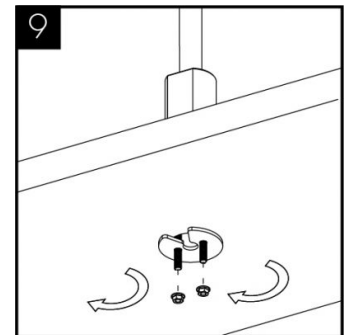

Tighten the 2 fixing flange nuts so that the worktop bracket is fixed up against the underside of the worktop.

Operation

Tap Control Panel

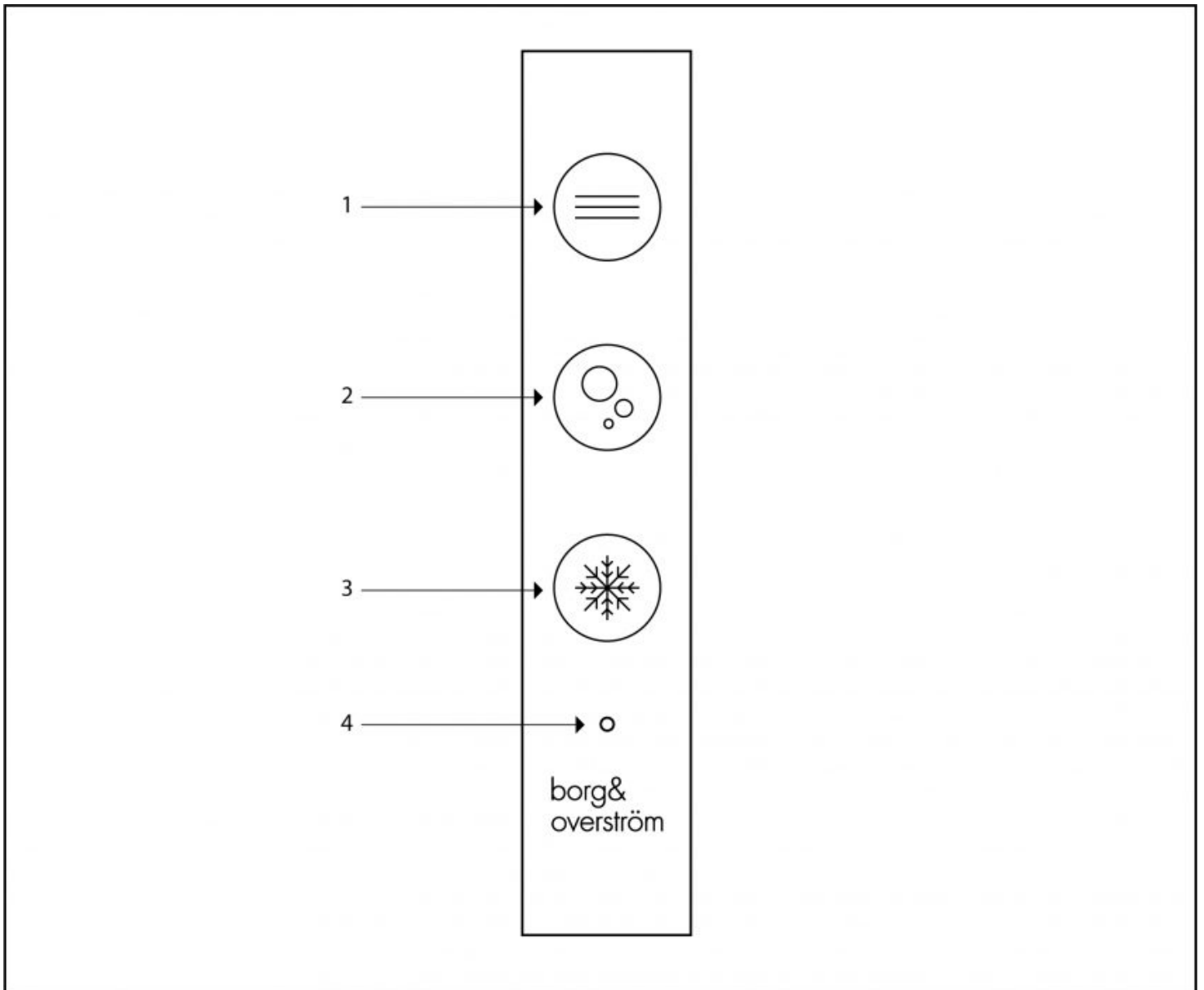

1. Ambient Dispense, 2. Sparkling Dispense, 3. Chilled Dispense,
4. Warning Symbol

Basic Functions

Dispensing from unit:

Press and hold dispense icon and release to finish dispense

Warning Symbol

'Warning' symbol will illuminate and flash upon a fault.

When Borg & Overström undercounter units are installed inside a cabinet or housing, adequate ventilation is recommended to ensure that they operate satisfactorily. During a cooling cycle it is normal for the unit to produce heat, and the purpose of ventilation is to provide a supply of air that can absorb the generated heat which would otherwise accumulate inside the cabinet or housing, and reduce the cooling performance of the unit. The amount

of heat generated by the cooling cycle depends directly upon the amount of usage – the higher the usage, the more heat produced. To provide adequate ventilation we recommend that air grilles/vents are fitted as supplied (or vent apertures formed) in the cabinet to allow an airflow as shown below. Normally this should be enough for all situations.

Important: Before making any cuts into the cupboard or kick board, ensure the area to be cut is free from water pipes or electrical cables. There is a risk of serious injury or death if electrical cables are cut, and significant damage to property if a water pipe is cut.

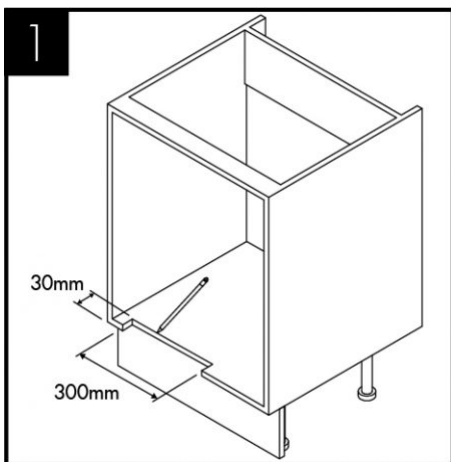

Using the template provided, carefully mark and cut the aperture to the edge of the cabinet.

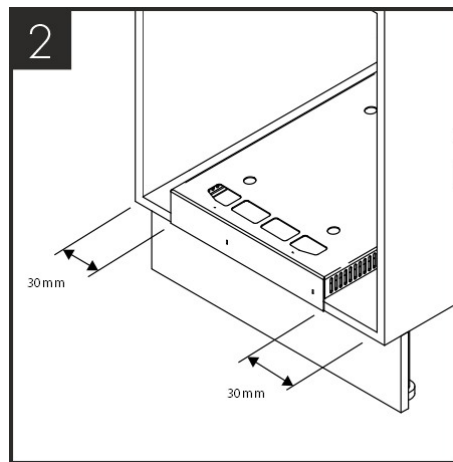

Situate the ProCore Simple-fit ventilation base in place centrally over the aperture. Ensuring that there is a minimum of 30mm air gap to each side.

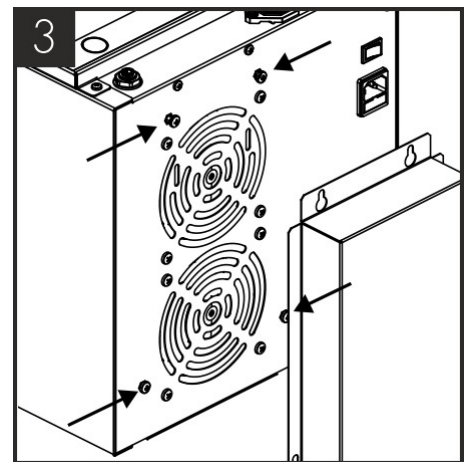

Insert 4 screws into the holes located. Do not overtighten at this stage.

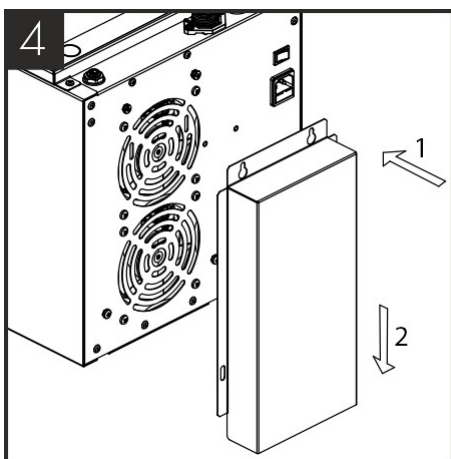

Place the rear vent chimney over the 4 screws and slide downwards into place.

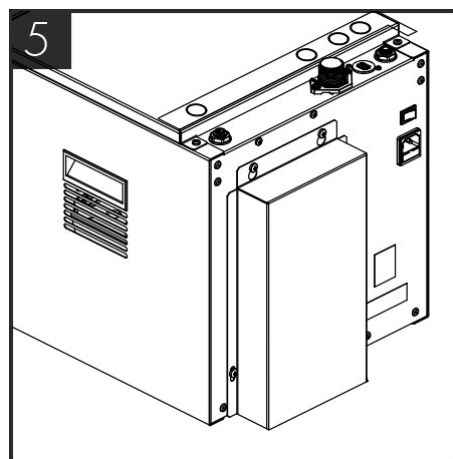

Tighten all 4 fixing screws.

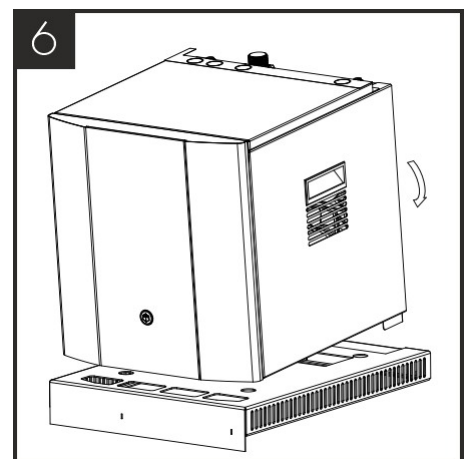

Lift and tilt the unit into position ready to lower.

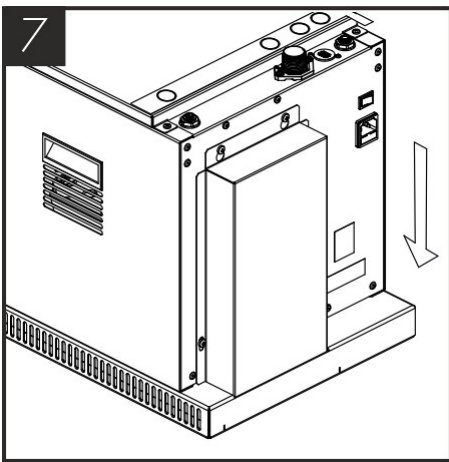

Lower the appliance carefully into position on the ventilation base to ensure the chimney is located correctly in the chimney aperture at the rear of the base.

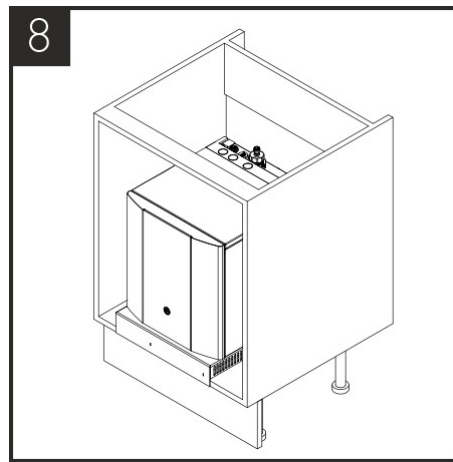

After installation the vents at the front of the cabinet and to the sides of the ventilation base must not be obstructed.

NOTE: Any obstructions will adversely affect the airflow to the appliance causing potential for poor performance, over heating or fridge failure.

ProCore Installation & Water Connection

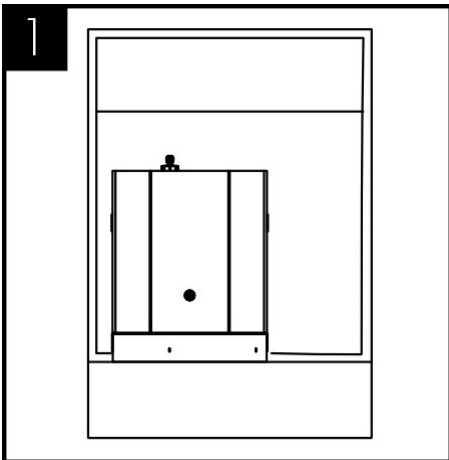

Locate the ProCore in a suitable position, using the supplied ventilation base by following the instructions above.

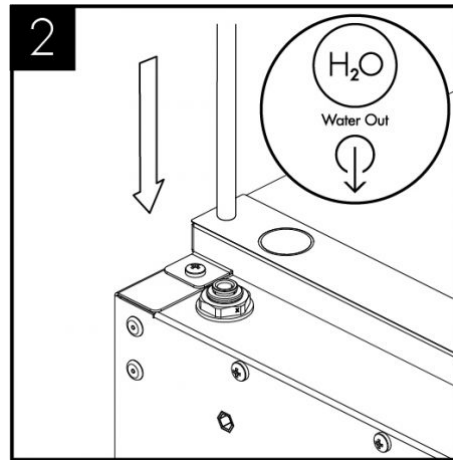

Connect the T1 tap to the water outlet.

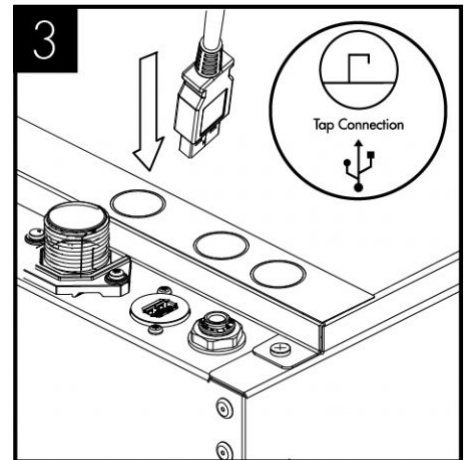

Connect the T1 Tap USB to the ProCore unit.

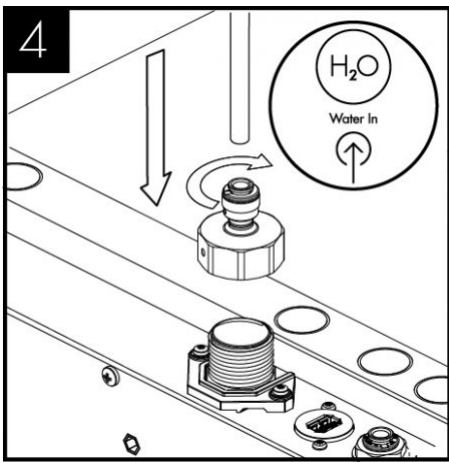

4
Connect the Water Inlet adapter as supplied and connect to water supply.

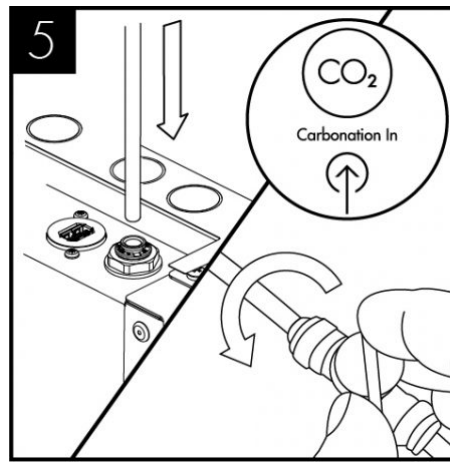

5
Connect the CO2 supply from gas regulator, ensuring the pressure is set to max 58 PSI (4 bar), and turn on the supply (See CO2 Installation section)

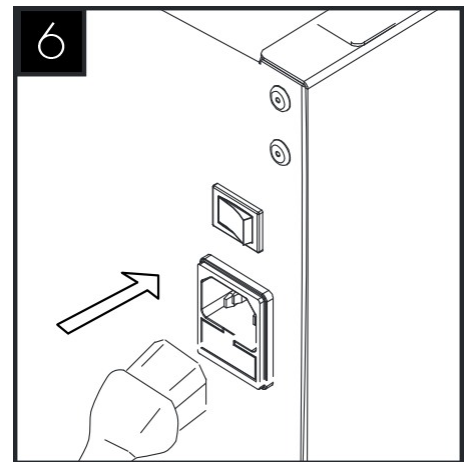

6
Connect the chiller to the electricity supply.

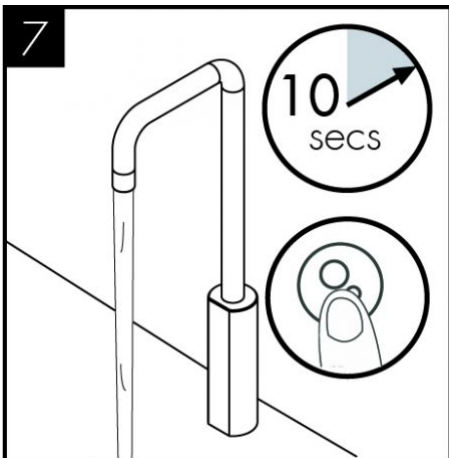

7
The carbonator should be purged of air by activating the sparkling water dispense for approximately 10 seconds.

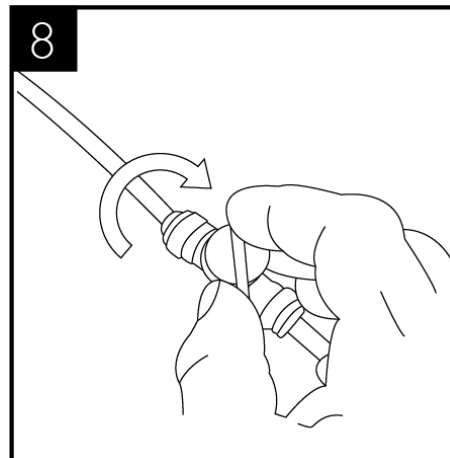

8
Turn on the water supply to fill the tank.

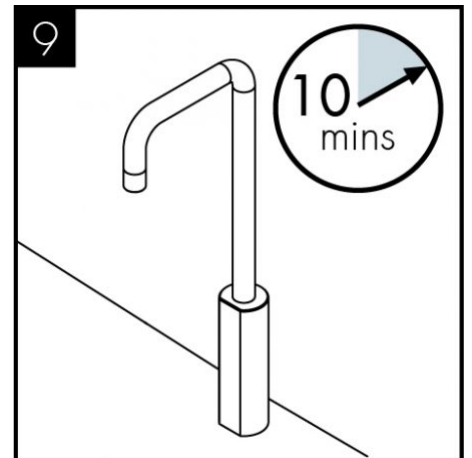

9
Allow the machine to stand for 8 - 12 minutes for the initial chilling process to complete.

CO2 Bottle Installation - Sparkling Versions Only

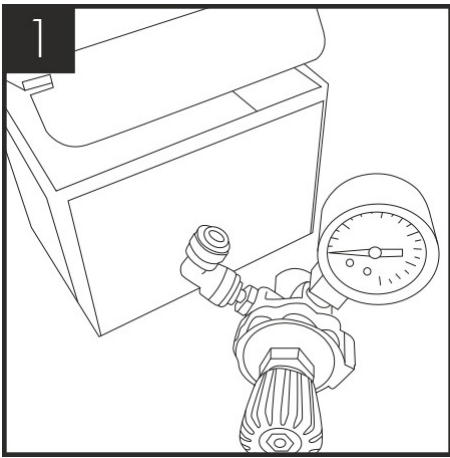

1
Unpack CO2 Regulator and fit elbow fitting to spigot outlet.

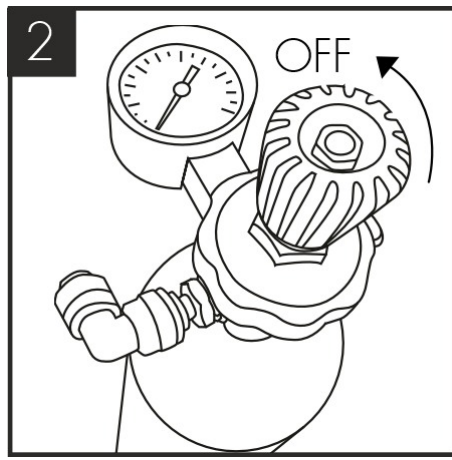

2
Attach the regulator to the disposable CO2 bottle, ensuring the small pressure relief vent in the stem is facing away from you or anyone else. Ensure the regulator is closed. Hand tighten securely.

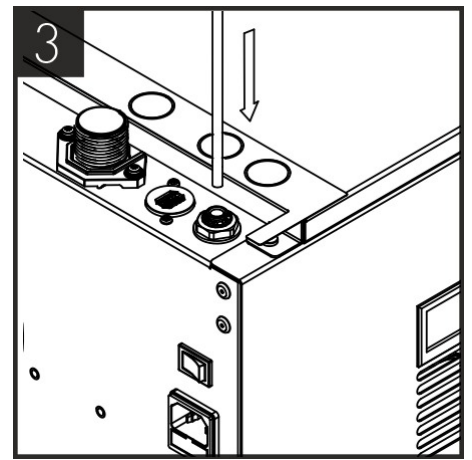

3
Connect the assembled CO2 bottle and regulator to the CO2 inlet using a 1/4" pipe.

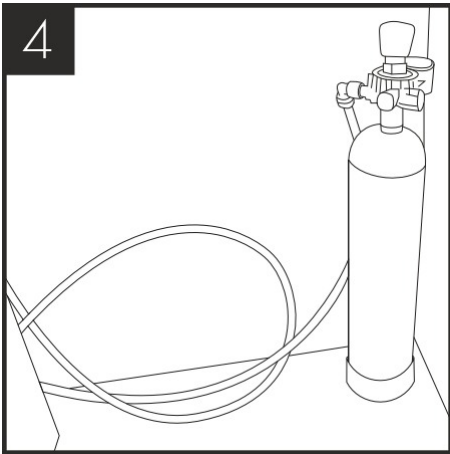

4
Stand the cylinder in a suitable place.

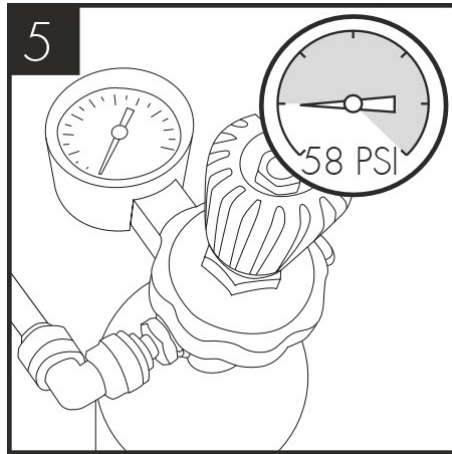

5
We recommend between 3.5 - 4 bar (58 PSI) (max). Do not exceed 4 bar pressure.

Sparkling Water Flow Rate - Sparkling Versions Only

NOTE: Sparkling water flow rate factory setting = 2.4L per minute MAX. This may need adjusting depending on inlet pressure. To do so follow below steps:

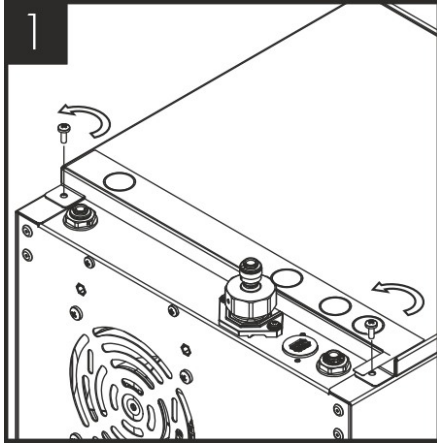

1
Remove the 2 screws holding the unit lid down and slide the lid off.

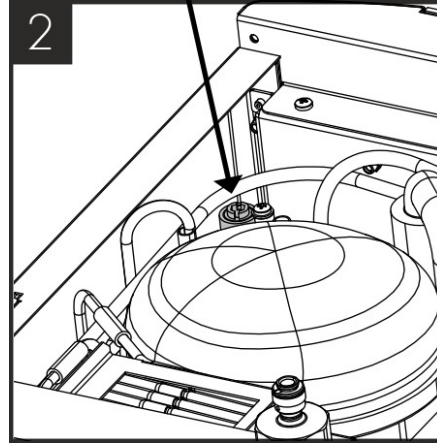

2
Locate the flow control adjuster, this can be found towards the front of the unit.

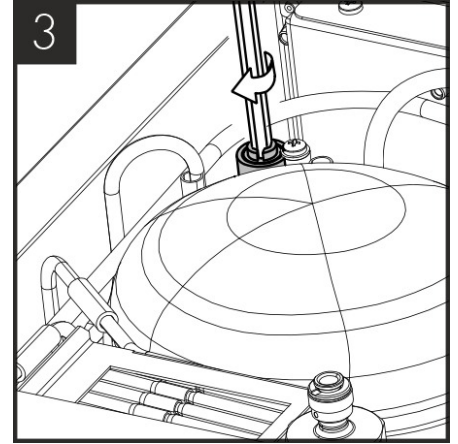

3
Using a M6 hex key flow can then be adjusted as follows: turn the hex key anti-clockwise to increase flow and clockwise to restrict flow. After each adjustment the flow rate should be timed to an acceptable flow rate and/or uninterrupted sparkling dispense

Once the correct flow rate is achieved place the cover back on to the unit by sliding it in place and replacing the screws.

Maintenance & Cleaning

Sanitisation Guide

NOTE: All maintenance operations must be carried out with the dispenser switched off. This operation must only be carried out by trained staff. Every 6 months a sanitisation procedure is recommended as follows:

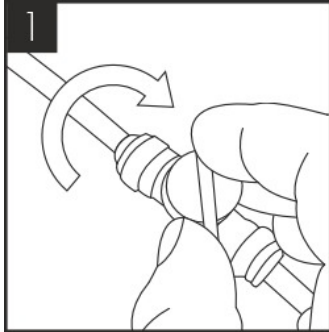

1 Turn off incoming mains water.

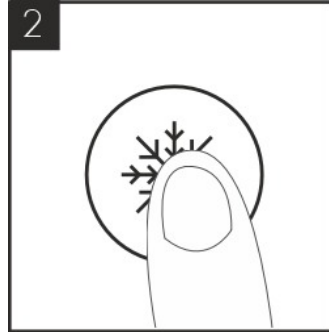

2 Briefly press chilled dispense button to release internal water pressure from the machine.

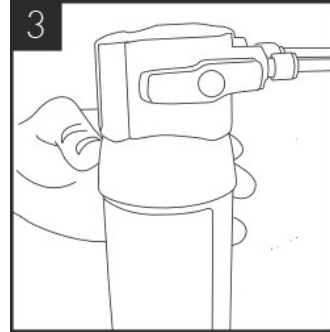

3 Remove the existing filter.



4 Use Sterizen Hand Gel and put on protective gloves.



5 Add 25 ml of Sterizen 30 to a clean and empty service filter cartridge.

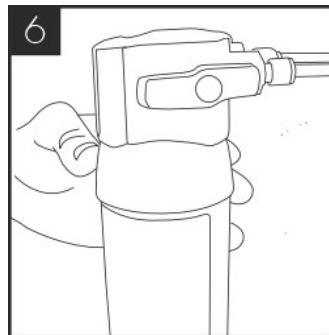

6 Connect to filter head.



7 Turn on incoming water, allow service cartridge/doser to fill.

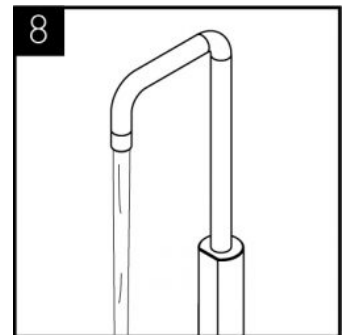

8 Dispense water using the chilled button. Repeat with sparkling button.



Leave the solution inside machine for sanitisation to take effect (minimum 5 minutes) while thoroughly cleaning the ProCore externally.

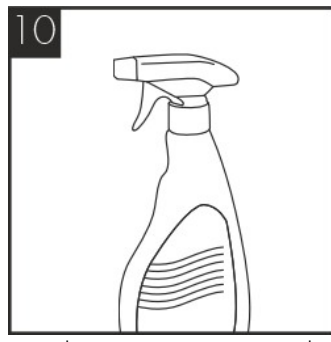

For this we recommend the use of Sterizen sanitising solution.



Pay particular attention to the dispense faucet and the push button controls. For this use Sterizen External Sanitiser and Sanitising Wipes.

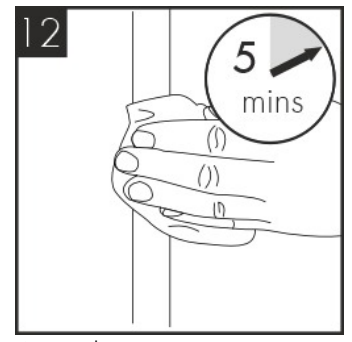

Attend to any cosmetic marks as needed.

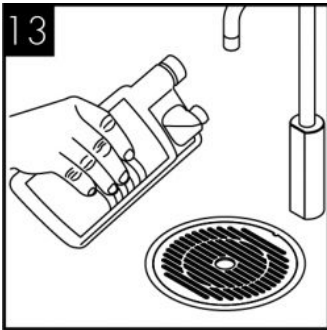

Remember to include the drip tray. If a Waste Overflow System is fitted, empty this and flush through with a small amount of sanitisation fluid if needed.

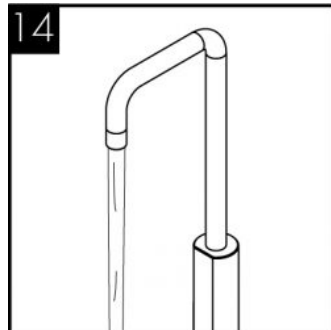

When the external cleaning (minimum 5 minutes) is completed, flush the machine using the chilled button with clean water until the dispense water runs clear. Repeat briefly with the ambient and sparkling buttons if present.

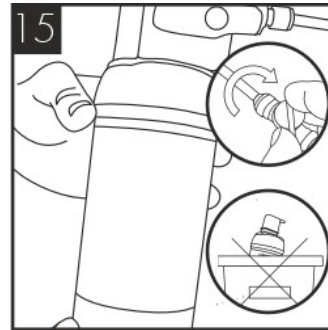

Turn off water and remove the service filter. Retain service filter for reuse.

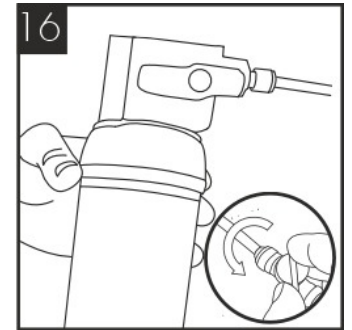

Fit new filter. Turn on incoming water supply and reconnect the power.

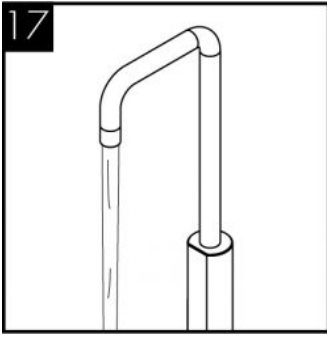

Pre-flush the new filter to waste using the chilled button until the water appears clear and is free of air. Flush through a small amount of water to check all functions.



Please note that this sanitisation fluid contains an active caustic/alkaline agent.

Always use responsibly and with care remembering that due to its alkaline nature unnecessary concentrated/prolonged contact with any materials, including metals, can cause damage.

Always rinse all contact surfaces after use with clean water.



Avoid skin contact and wear protective gloves when handling sanitisation fluids.



In the event of any skin contact, flush immediately with clean, cold water.

Emptying the CO2 Tank

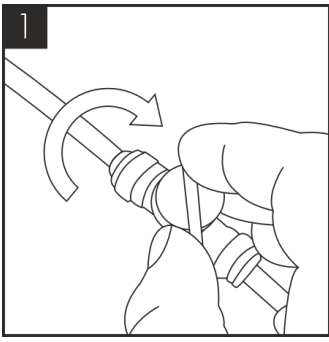

1
Turn off the water supply.

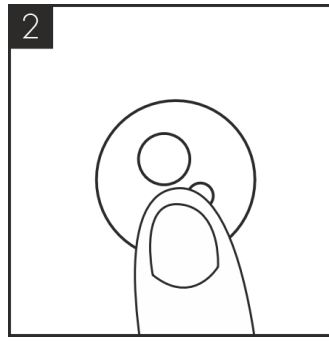

2
Press and hold the Sparkling water dispense button until all the water is expelled and only CO₂ gas is being released.

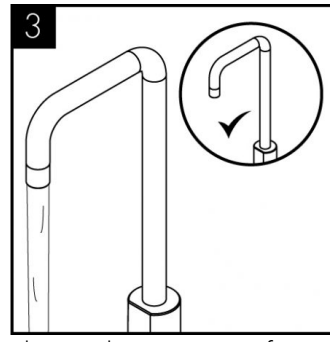

3
The tank is empty of sparkling water when only CO₂ is being released.

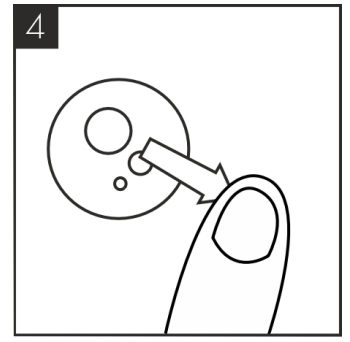

4
Ensure to release the Sparkling water button and take care to avoid releasing excess amounts of CO₂ gas as this may damage the tank.

Advanced Troubleshooting

Fault Diagnostics

Problem/Report	Possible Cause	Suggested Action
No Water Dispensing	Water Pressure Regulator	Check water flow through the regulator. Replace if necessary.
No Sparkling Water	No CO2 pressure	Check CO2 bottle, regulator and non-return valve. Supply pressure should be 58 psi (4bar), replace as necessary.
	Carbonator Tank Not Filling	Check carbonator probe for possible short circuit to ground. Check for pump timeout, cycle power off & on then purge carbonator.
	Water isolated from machine	Check water inlet supply.
Poor Quality Carbonation	Incorrect CO2 Pressure	Check CO2 bottle, regulator and non-return valve. Supply pressure should be 58 psi (4bar), replace as necessary.
	Air in Carbonator Tank	Visit to view steps for purging tank.
	Residue in Carbonator Tank	After prolonged use, a surface film can develop within the carbonator tank. Refer to cleaning and sanitising instructions.
Warm Drinks	Insufficient cooling air flow through the fridge.	Check that the condenser is not blocked. Check supply to cooling fans (230V AC). If supply present replace fans. If supply not present move on to the compressor. The supply to the fans and the compressor are linked.
	Compressor not running	Check supply to compressor (230V AC). Check NTC probe is not faulty Check for system over heat. Allow the unit to cool and check for airflow obstructions. Once the unit has cooled the fridge system will restart. If the problem persists contact technical support.
	Fridge failure (See fault codes)	If compressor & fan are running and there is no cooling contact technical support.

Technical Information

T1 Chilled & Ambient Circuit Schematic

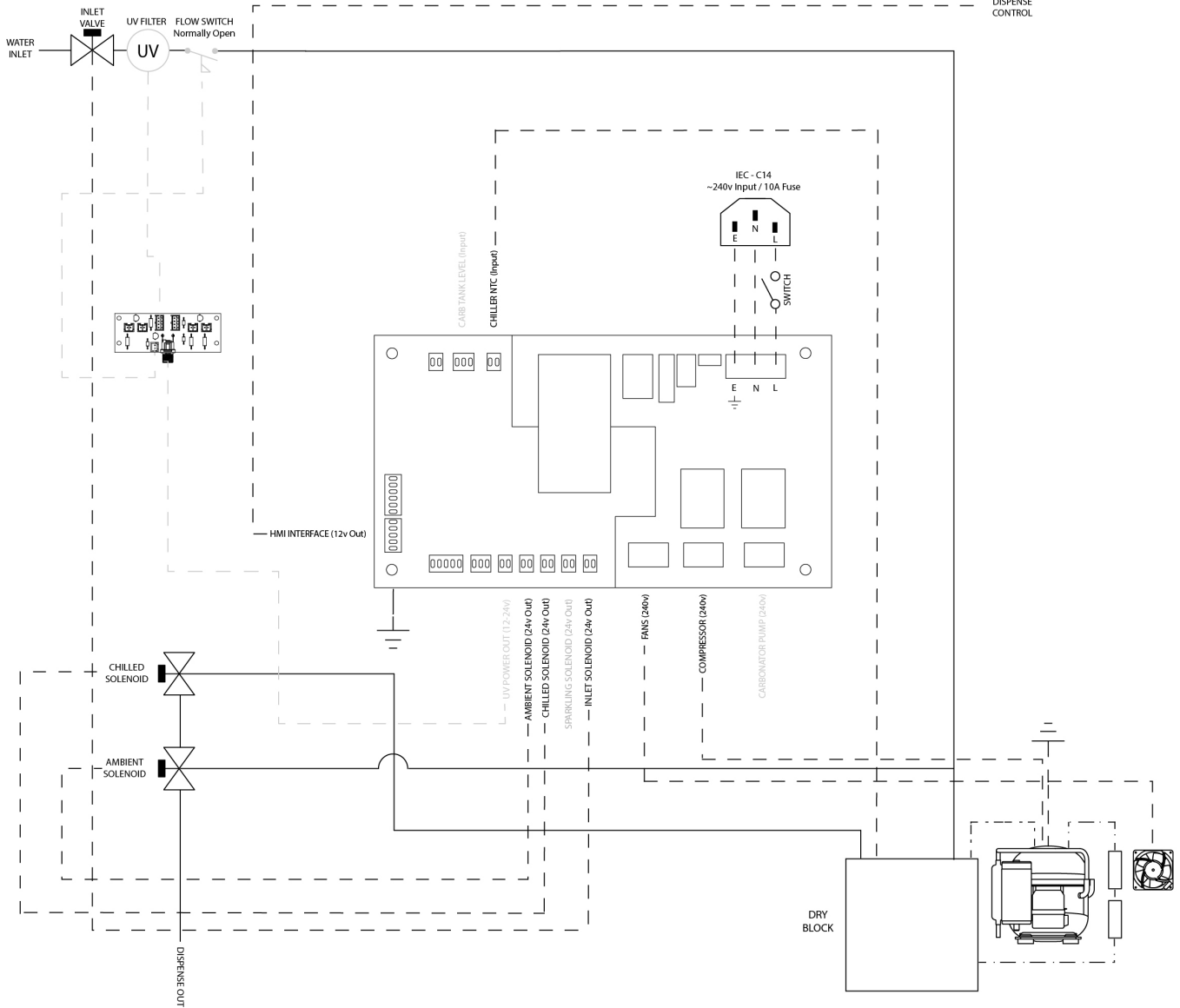

T1 Chilled & Sparkling Circuit Schematic



T1 Chilled, Ambient & Sparkling Circuit Schematic

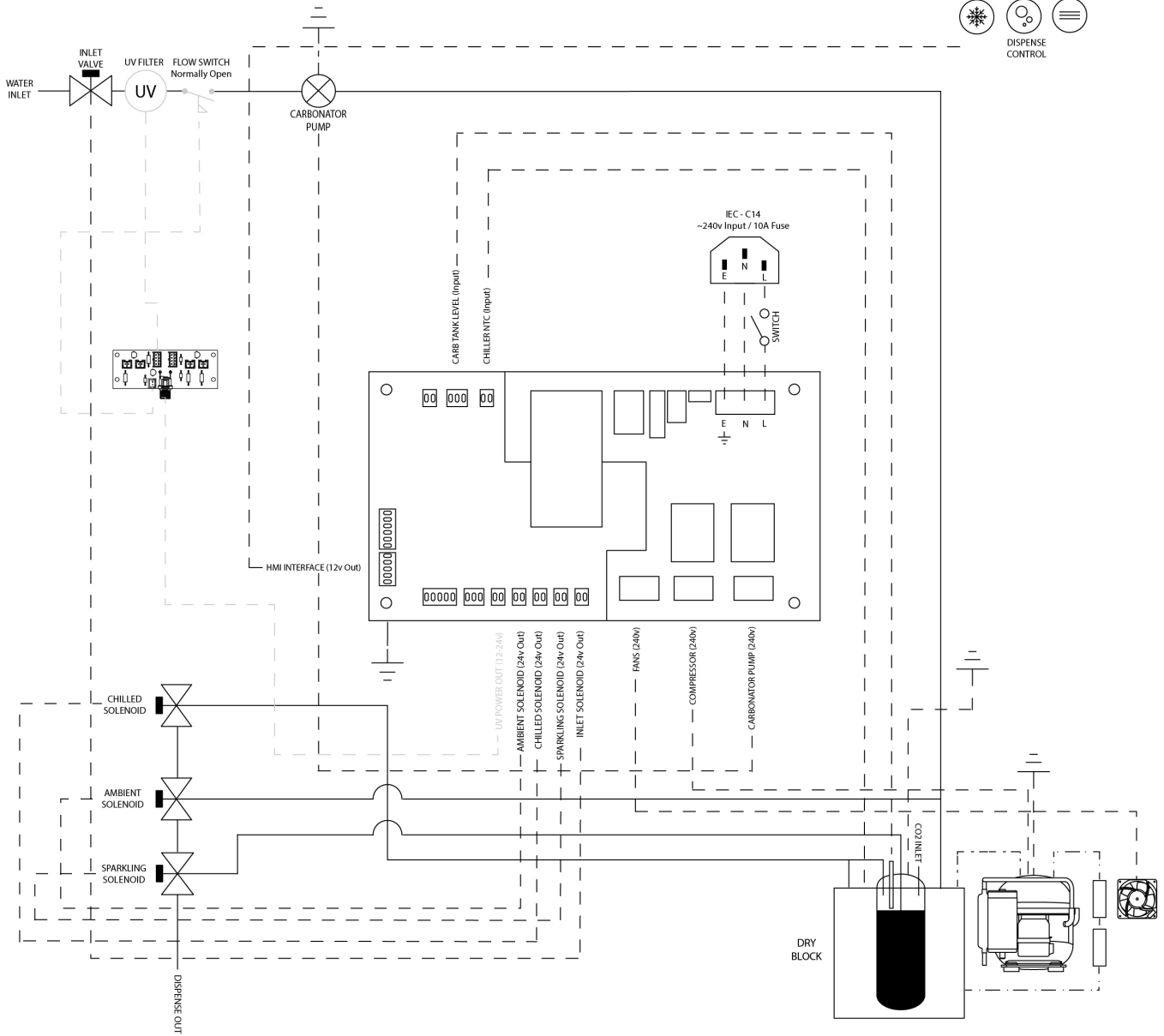

Water Pathway - Chilled & Ambient

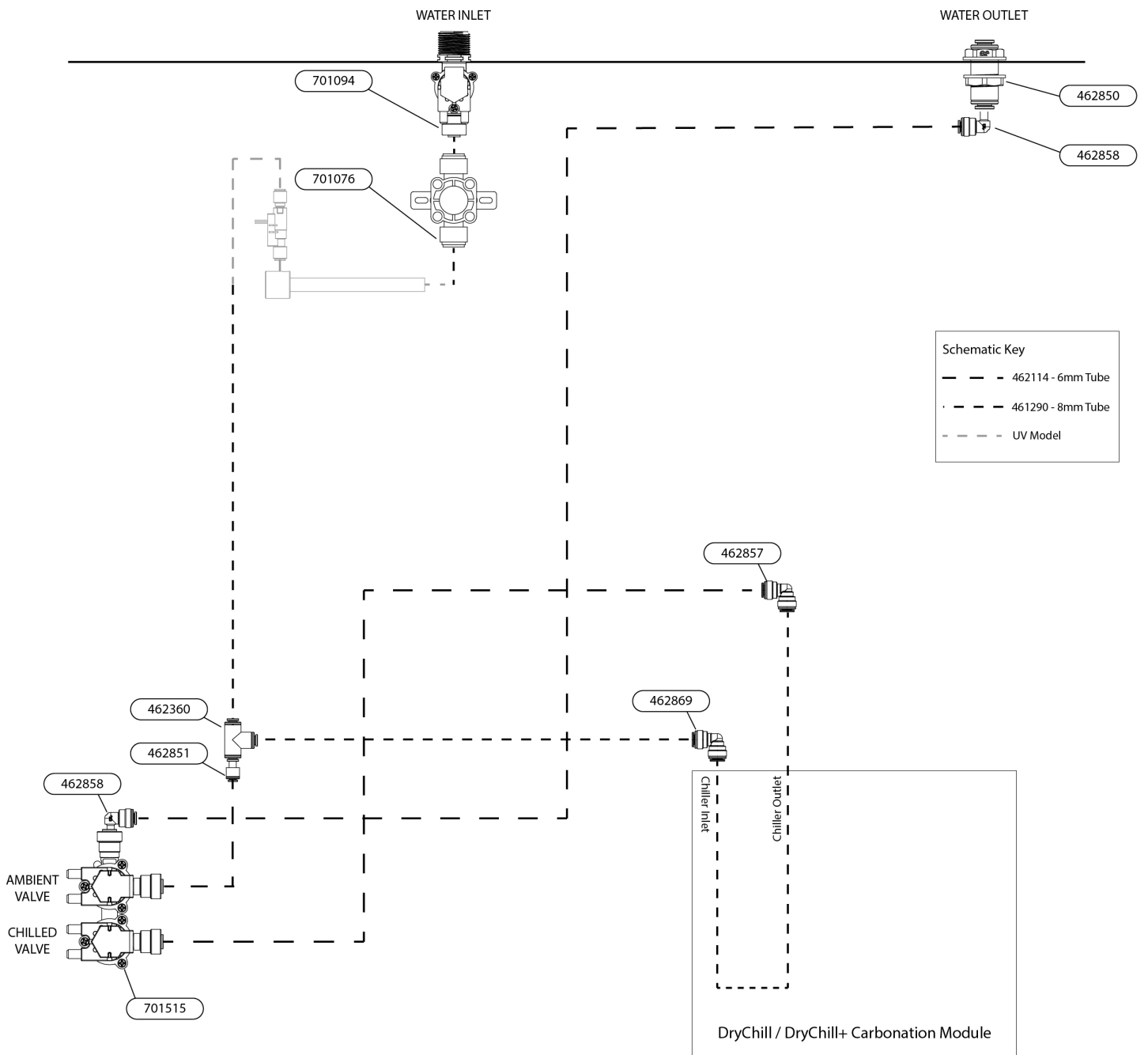

Water Pathway - Chilled & Sparkling

Water Pathway - Chilled, Ambient & Sparkling

Spares

ProCore Exploded Parts Diagram

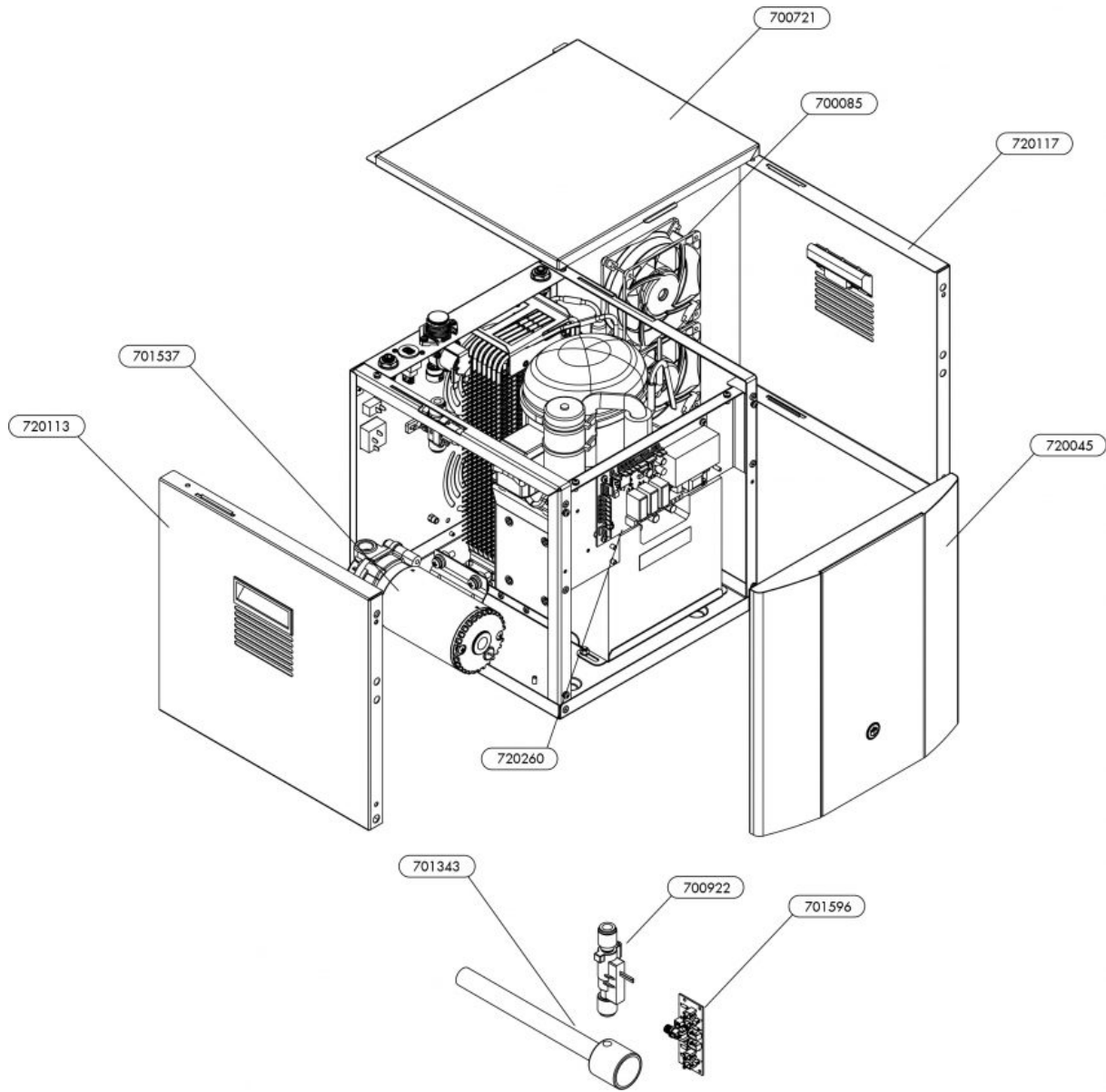

T1 Exploded Parts Diagram

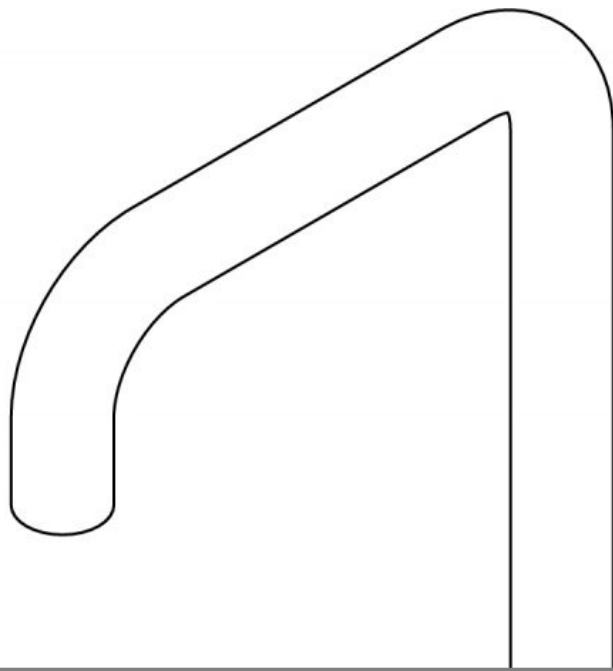

700092



Spares List

Part No.	Description	CA	CS	CSA
720260	PCBA Lite Control Board	•	•	•
700721	Top Panel Asm	•	•	•
720117	Right Panel Asm	•	•	•
720113	Left Panel Asm	•	•	•
720045	Front Panel Asm	•	•	•
701537	Pump	•	•	•
700085	Cooling Fan	•	•	•
701343	UV Asm	•	•	•
700922	Flow Switch	•	•	•
701596	UV Control Board	•	•	•

Part No.	Description	CA	CS	CSA
701094	3/4" BSP Inlet Solenoid	•	•	•
462325	1/4" Bulkhead Connector		•	•
462850	6mm Bulkhead Connector	•	•	•
701076	8mm PRV - ProCore+	•	•	•
701515	6mm 2 Way Solenoid	•	•	
701525	6mm 3 Way Solenoid			•
462858	6mm Stem Elbow	•	•	•
462859	8mm Stem Elbow	•	•	•
462869	8mm Equal Elbow	•	•	•
462360	8mm Equal Tee	•	•	•
462375	5/16" - 1/4" Elbow		•	•
462851	8>6mm Straight Reducer	•	•	•
462857	8>6mm Reducing Elbow		•	•
701263	6mm Compensator		•	•
462667	8mm Safety Check Valve		•	•
462668	1/4" Safety Check Valve		•	•

Part No.	Description	CA	CS	CSA
700092	Laminar Flow Outlet	•	•	•
720112	Tap Outlet Polished Metal	•	•	•
701453	Tap Outlet Plated Black	•	•	•
720321	Touch Control Panel Asm CSA			•
720324	Touch Control Panel Asm CS		•	
720327	Touch Control Panel Asm CA	•		

