



ZEON-12 WINCH

Part Number: 89120

Rated Line Pull: 12,000 lbs. (5440 kgs)

Motor: 12V DC, Series Wound

Controls: Remote switch, 12' (3.7m) Lead

Gear train: 3-Stage Planetary

Gear Ratio: 216:1

Clutch (Freespool): Rotating Ring Gear

Brake: Automatic Direct Drive Cone

Drum diameter/length: 3.15"/9.3" (8.0cm/23.6cm)

Kit Shipping Weight: 103 lbs (46.7 kgs)

Rope: Wire rope, Ø 3/8" x 80' (Ø 9.5mm x 24.4m)

Fairlead: Roller

Recommended Battery: 650CCA Minimum for winching

Duty Cycle: Intermittent

Battery leads: 2 GA, 72" (1.83m)

Finish: Black Powder Coat

Warranty: Limited Lifetime

Mounting Bolt Pattern: 10.0" x 4.5" (254mm x 114.3mm)

Winch Dimensions: 24.25 L x 7.14" D x 10.52" H (615.9mm L x 181.6mm D x 267.1mmH)

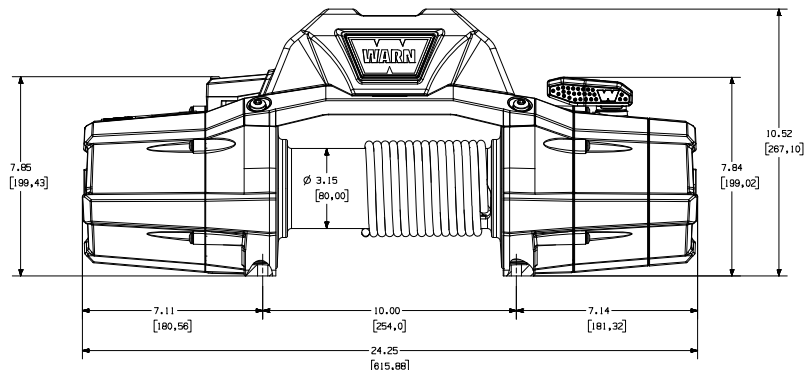

SERVICE INSTRUCTIONS

Should you encounter a problem during installation or operation of your winch, please follow these steps toward resolving the problem:

1. Refer to your operator's guide and installation instructions. It has illustrations and detailed information on the installation and safe and proper operation of your winch. It also includes a replacement parts list and assembly diagrams. If you are unable to resolve the problem, then go to step 2.
2. Contact your dealer where you purchased your winch. If, after discussing the problem with their parts and service staff, you are still unable to resolve the problem then go to step 3.
3. Call an Authorized WARN Service center from the list provided on the back of the warranty sheet included with the product. When calling, please have the following information available: winch model number and purchase date, make, model and year of vehicle.
4. If you are unable to resolve the problem to your satisfaction, please call Warn Industries Customer Service at: 1-800-543-9276. When calling, please have the following information available: winch model number and purchase date, make, model and year of vehicle. You may also contact Warn Industries by visiting our website: www.warn.com

SERVICE/UPGRADE KITS

	PN#	ITEM	QTY	DESCRIPTION
KIT 1	89304	8	1	S/P, TRANSMISSION 216, ASSY
		9	1	ROTATING RING GEAR
		(2)	1	RETAINING RING
		(3)	1	S/P, END HOUSING, ASSEMBLY
		(4)	1	S/P, END CAP
		10	1	S/P, DRUM SUPPORT, GEARTRAIN
		11	1	SUN GEAR, 12T
		21	1	CARRIER ASSY, STAGE 1
		12	1	DRIVE SHAFT
		13	1	CARRIER ASSY, STAGE 2
		14	1	WASHER, THRUST
		15	1	CARRIER ASSY, STAGE 3
		20	1	RING GEAR, 75T
		42	1	DRIVE SPLINE
KIT 2	89237	6	1	S/P, END HOUSING, ASSEMBLY
		5	1	CLUTCH LEVER
		7	1	SEAL, O-RING
		8	1	DETENT, M5 SCREW
		9	1	ROTATING RING GEAR
		2	1	RETAINING RING
		6	1	GASKET, END CAP
		3	1	GEARTRAIN GASKET
		10	10	TORX, PAN HEAD, M5-0.8 x 25

KIT 3	89238			S/P, END CAP	
			1	1	END CAP
			2	1	GASKET, END CAP
			3	5	TORX, PAN HEAD, M5-0.8 x 25
KIT 4	89239		1	S/P, DRUM SUPPORT, GEARTRAIN	
			17	1	DRUM SUPPORT, GEARTRAIN
			18	1	DRUM BUSHING
			19	1	DRUM SEAL
			16	1	GEARTRAIN GASKET
			3	5	TORX, PAN HEAD, M5-0.8 x 25
KIT 5	89240			S/P, BRAKE ASSY	
			22	1	BRAKE ASSY
			21	1	DRIVE SHAFT
			23	1	CASTING, MOTOR COUPLER
			24	1	DRUM
KIT 6	89301			S/P, MOTOR 5 TURN	
			27	1	MOTOR 5 TURN
			25	1	DRUM BUSHING, MOTOR
			19	1	DRUM SEAL
KIT 7	89211			S/P, CONTROL PACK	
			30	1	S/P 12VDC CONTACTOR PLATE ASSEMBLY
			28	1	S/P CONTROL PACK COVER ASSEMBLY
			26	1	GROUND CABLE 2GA
			37	1	POWER CABLE 2GA
KIT 8	89627			S/P BUS BARS	
			33	1	BUS BARS
			35	1	TOP, BUSS BAR COVER
			34	1	BASE, BUSS BAR COVER
			36	1	TORX, PAN HEAD, M6-1.0 x 25
INDIVIDUAL ITEMS		10	1	SUN GEAR, 12T	
	13874	10	1	SUN GEAR, 12T	
	88636	11	1	CARRIER ASSY, STAGE 1	
	88251	21	1	DRIVE SHAFT	
	91047	12	1	CARRIER ASSY, STAGE 2	
	88543	13	1	WASHER, THRUST	
	88521	14	1	CARRIER ASSY, STAGE 3	
	88252	15	1	RING GEAR, 75T	
	90281	20	1	DRIVE SPLINE	
	13824	42	1	DRUM DRIVER	
	90053	41	1	ANCHOR PUCK	
	89242	32	1	S/P, TIE PLATE	
	89213	38	1	S/P, WIRE ROPE, 3/8x80'	
	89214	39	1	S/P, FAIRLEAD, ROLLER	
	81400	29	1	S/P 12VDC CONTACTOR	
	89626	30	1	S/P 12VDC CONTACTOR PLATE ASSEMBLY	
	89244	28	1	S/P CONTROL PACK COVER ASSEMBLY	
	83665	40	1	S/P REMOTE CONTROL	
	15901	26	1	GROUND CABLE 2GA	
	83350	37	1	POWER CABLE 2GA	
88371	3	10	TORX, PAN HEAD, M5-0.8 x 25		
88682	26	1	TORX, PAN HEAD, M6-1.0 x 25		
83475	31	4	TORX, PAN HEAD, M8-1.25 x 25		



TREUIL ZEON-12

Référence : 89120

Effort en 1ère couche : 5440 kg (12 000 livres)

Moteur : 12 V CC, à enroulements série

Commandes : Interrupteur à distance, fil de 3,7 m (12')

Train d'engrenages : Planétaire à 3 étages

Rapport de démultiplication : 216:1

Embrayage (déroutement en roue libre) : Couronne dentée rotative

Frein : Automatique, à came excentrée

Longueur/Diamètre du tambour : 8,0 cm/23,6 cm (3,15 po/9,3 po)

Poids d'expédition du kit : 46,7 kg (103 livres)

Câble : Câble d'acier, Ø 9,5 mm x 24,4 m (3/8 po x 80 pieds)

Guide-câble : Rouleau

Batterie conseillée : 650 A (démarrage à froid) minimum pour le halage

Cycle d'utilisation : Intermittent

Fils de batterie : 2 GA, 1,83 m (72 po)

Finition : Revêtement époxy noir

Garantie : À vie limitée

Entraxe de fixation : 254 mm x 114,3 mm (10,0 po x 4,5 po)

Dimensions du treuil : L x P x H 615,9 mm x 181,6 mm x 267,1 mm (24,25 po x 7,14 po x 10,52 po)

