



ZEON 12-S WINCH

Part Number: 95950

Rated Line Pull: 12,000 lbs. (5440 kgs)

Motor: 12V DC, Series Wound

Controls: Remote switch, 12' (3.7m) Lead

Gear train: 3-Stage Planetary

Gear Ratio: 216:1

Clutch (Freespool): Rotating Ring Gear

Brake: Automatic Direct Drive Cone

Drum diameter/length: 3.15"/9.3" (8.0cm/23.6cm)

Kit Shipping Weight: 80 lbs (36.3 kgs)

Rope: Synthetic, Ø 3/8" x 80' (Ø 9.5mm x 24.4m)

Fairlead: Hawse

Recommended Battery: 650CCA Minimum for winching

Duty Cycle: Intermittent

Battery leads: 2 GA, 72" (1.83m)

Finish: Black Powder Coat

Warranty: Limited Lifetime

Mounting Bolt Pattern: 10.0" x 4.5" (254mm x 114.3mm)

Winch Dimensions: 24.25 L x 7.14" D x 10.52" H (615.9mm L x 181.6mm D x 267.1mmH)

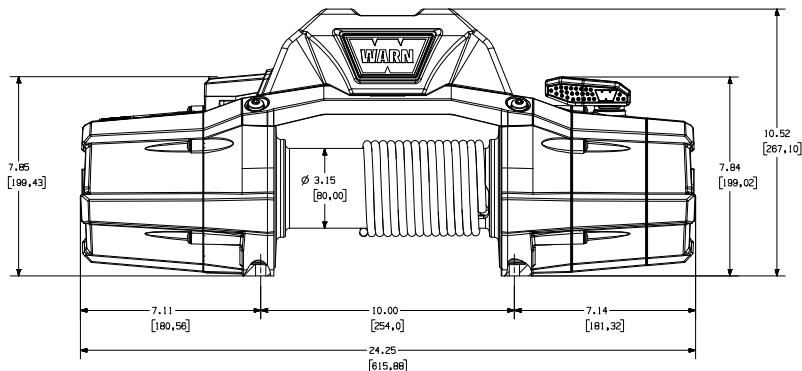

SERVICE INSTRUCTIONS

Should you encounter a problem during installation or operation of your winch, please follow these steps toward resolving the problem:

1. Refer to your operator's guide and installation instructions. It has illustrations and detailed information on the installation and safe and proper operation of your winch. It also includes a replacement parts list and assembly diagrams. If you are unable to resolve the problem, then go to step 2.
2. Contact your dealer where you purchased your winch. If, after discussing the problem with their parts and service staff, you are still unable to resolve the problem then go to step 3.
3. Call an Authorized WARN Service center from the list provided on the back of the warranty sheet included with the product. When calling, please have the following information available: winch model number and purchase date, make, model and year of vehicle.
4. If you are unable to resolve the problem to your satisfaction, please call Warn Industries Customer Service at: 1-800-543-9276. When calling, please have the following information available: winch model number and purchase date, make, model and year of vehicle. You may also contact Warn Industries by visiting our website: www.warn.com

SERVICE/UPGRADE KITS

	PN#	ITEM	QTY	DESCRIPTION
KIT 1	89304	8	1	S/P, TRANSMISSION 216, ASSY
		9	1	ROTATING RING GEAR
		(2)	1	RETAINING RING
		(3)	1	S/P, END HOUSING, ASSEMBLY
		(4)	1	S/P, END CAP
		10	1	S/P, DRUM SUPPORT, GEARTRAIN
		11	1	SUN GEAR, 12T
		21	1	CARRIER ASSY, STAGE 1
		21	1	DRIVE SHAFT
		12	1	CARRIER ASSY, STAGE 2
		13	1	WASHER, THRUST
		14	1	CARRIER ASSY, STAGE 3
		15	1	RING GEAR, 75T
		20	1	DRIVE SPLINE
42	1	DRUM DRIVER		
KIT 2	89237	6	1	S/P, END HOUSING, ASSEMBLY
		5	1	CLUTCH LEVER
		7	1	SEAL, O-RING
		7	1	DETENT, M5 SCREW
		8	1	ROTATING RING GEAR
		9	1	RETAINING RING
		2	1	GASKET, END CAP
		6	1	GEARTRAIN GASKET
		3	10	TORX, PAN HEAD, M5-0.8 x 25

KIT 3	89238	1	1	S/P, END CAP	
		2	1	END CAP	
		3	5	GASKET, END CAP	
KIT 4	89239		1	TORX, PAN HEAD, M5-0.8 x 25	
		17	1	S/P, DRUM SUPPORT, GEARTRAIN	
		18	1	DRUM SUPPORT, GEARTRAIN	
		19	1	DRUM BUSHING	
		16	1	DRUM SEAL	
		3	5	GEARTRAIN GASKET	
KIT 5	89240			TORX, PAN HEAD, M5-0.8 x 25	
		22	1	S/P, BRAKE ASSY	
		21	1	BRAKE ASSY	
		23	1	DRIVE SHAFT	
		24	1	CASTING, MOTOR COUPLER	
KIT 6	95633			DRUM	
		27	1	S/P, MOTOR 5 TURN	
		25	1	MOTOR 5 TURN	
		19	1	DRUM BUSHING, MOTOR	
KIT 7	89211			DRUM SEAL	
		30	1	S/P, CONTROL PACK	
		28	1	S/P 12VDC CONTACTOR PLATE ASSEMBLY	
		26	1	S/P CONTROL PACK COVER ASSEMBLY	
		37	1	GROUND CABLE 2GA	
KIT 8	89627			POWER CABLE 2GA	
		33	1	S/P BUS BARS	
		35	1	BUS BARS	
		34	1	TOP, BUSS BAR COVER	
		36	1	BASE, BUSS BAR COVER	
INDIVIDUAL ITEMS				TORX, PAN HEAD, M6-1.0 x 25	
		13874	10	1	SUN GEAR, 12T
		88636	11	1	CARRIER ASSY, STAGE 1
		88251	21	1	DRIVE SHAFT
		91047	12	1	CARRIER ASSY, STAGE 2
		88543	13	1	WASHER, THRUST
		88521	14	1	CARRIER ASSY, STAGE 3
		88252	15	1	RING GEAR, 75T
		90281	20	1	DRIVE SPLINE
		13824	42	1	DRUM DRIVER
		90052	41	1	ANCHOR PUCK
		89242	32	1	S/P, TIE PLATE
		93120	38	1	S/P, SYNTHETIC ROPE ASSY, 3/8x80'
		87914	39	1	S/P, FAIRLEAD, HAWSE
		81400	29	1	S/P 12VDC CONTACTOR
		89626	30	1	S/P 12VDC CONTACTOR PLATE ASSEMBLY
		89244	28	1	S/P CONTROL PACK COVER ASSEMBLY
		83665	40	1	S/P REMOTE CONTROL
		15901	26	1	GROUND CABLE 2GA
		83350	37	1	POWER CABLE 2GA
		88371	3	10	TORX, PAN HEAD, M5-0.8 x 25
		88682	26	1	TORX, PAN HEAD, M6-1.0 x 25
		83475	31	4	TORX, PAN HEAD, M8-1.25 x 25



TREUIL ZEON 12-S

Référence : 95950

Effort en 1ère couche : 5440 kg (12 000 livres)

Moteur : 12 V CC, à enroulements série

Commandes : Interrupteur à distance, fil de 3,7 m (12')

Train d'engrenages : Planétaire à 3 étages

Rapport de démultiplication : 216:1

Embrayage (déroutement en roue libre) : Couronne dentée rotative

Frein : Automatique, à came excentrée

Longueur/Diamètre du tambour : 8,0 cm/23,6 cm (3,15 po/9,3 po)

Poids d'expédition du kit : 36,3 kg (80 livres)

Câble : Câble synthétique, Ø 9,5 mm x 24,4m (3/8 po x 80 pieds)

Guide-câble : Écubier

Batterie conseillée : 650 A (démarrage à froid) minimum pour le halage

Cycle d'utilisation : Intermittent

Fils de batterie : 2 GA, 1,83 m (72 po)

Finition : Revêtement époxy noir

Garantie : À vie limitée

Entraxe de fixation : 254 mm x 114,3 mm (10,0 po x 4,5 po)

Dimensions du treuil : L x P x H 615,9 mm x 181,6 mm x 267,1 mm
(24,25 po x 7,14 po x 10,52 po)

