

EVENT LIGHTING

PRO PAR

Model No. PARRGBW12x8, PAR12x8A

PARRGBW5x8, PAR5x8A

USER MANUAL



For safety, please read this user manual carefully before initial use.

Event Lighting reserves the right to revise the manual at any time. Information and specifications within this manual are subject to change without notice. Event Lighting assumes no liability or responsibility for any errors or omissions. Please consult Event Lighting for any clarification or information regarding this item.

www.event-lighting.com.au

Ver 2.0

CONTENTS

Safety Instructions

- Power input & power Linking

Product Installation

- Fuse replacement

Diagrams

- Lux chart
- Dimensions

Control Board Operation

- DMX address setting
- DMX modes setting
- Dimmer Speed Setting
- Static colour setting
- Manual colour setting
- Auto run and sound active setting
- Master/slave setting

DMX chart

Technical specifications

Warranty

Safety Instructions

WARNING

- Do not open this device, there is no user-serviceable parts inside. Risk of electric shock.
- Do not look at the light source when the device is on.
- **CAUTION:** This unit's housing may be hot during and after operation.
- Install this device in a location with adequate ventilation, at least 20 inch (50 cm) from adjacent surfaces.
- Do not leave any flammable material within 50 cm of this unit while operating or connected to power.
- Use a safety chain when mounting this device overhead.
- Do not operate this device outdoors or in any location where dust, excessive heat, water, or humidity may affect it.
- Do not operate this device if the housing, lenses, or cables appear damaged.
- Do not connect this device to a dimmer or rheostat.
- **ONLY** connect this device to a grounded and protected circuit.
- **ONLY** use the hanging bracket to carry this device.
- In case of a serious operating problem, stop using immediately.
- The maximum ambient temperature is 104° F (40° C). Do not operate this device at higher temperatures.

Power Input & Power Linking

This device has an auto-switching power supply work with input voltage range of 100~240 VAC, 50/60 Hz. Link up to the maximum 8A. DO NOT exceed this number.

Product Installation

This device can be mounted in many orientations provided each individual device is secured by the use of correct mounting bracket.

Use a safety chain when mounting this device overhead.

Fuse Replacement

If the fine-wire fuse of the device fuses, only replace the fuse by a fuse of same type and rating.

Before replacing the fuse, unplug mains lead.

Procedure:

Step 1: Unscrew the fuse holder on the rear panel with a fitting screwdriver from the housing (anticlockwise).

Step 2: Remove the old fuse from the fuse holder.

Step 3: Install the new fuse in the fuse holder.

Step 4: Replace the fuse holder in the housing and fix it.

Lux Chart

PARRGBW5X8

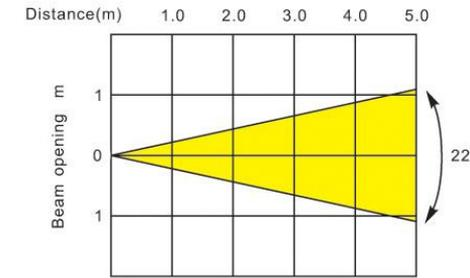

| Diameter(m) | 0.52 | 0.93 | 1.33 | 1.74 | 2.14 |
|-----------------|------|------|------|------|------|
| Intensity LUX R | 1784 | 457 | 210 | 118 | 78 |
| G | 1743 | 467 | 213 | 121 | 81 |
| B | 2327 | 588 | 273 | 149 | 98 |
| W | 2648 | 786 | 357 | 201 | 135 |
| Full | 7190 | 1910 | 883 | 489 | 338 |

PAR5X8A

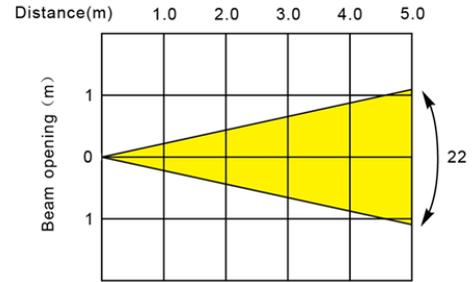

| Diameter(m) | 0.52 | 0.93 | 1.33 | 1.74 | 2.14 |
|-----------------|------|------|------|------|------|
| Intensity LUX R | 2600 | 626 | 271 | 157 | 108 |
| G | 2810 | 728 | 325 | 190 | 120 |
| B | 2100 | 500 | 230 | 135 | 82 |
| A | 2310 | 520 | 260 | 142 | 95 |
| Full | 5350 | 1350 | 605 | 348 | 235 |

PARRGBW12X8

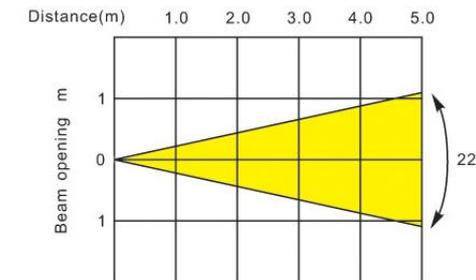

| Diameter(m) | 0.57 | 0.97 | 1.37 | 1.78 | 2.18 |
|-----------------|-------|------|------|------|------|
| Intensity LUX R | 3957 | 977 | 430 | 245 | 160 |
| G | 3900 | 1092 | 485 | 280 | 185 |
| B | 4690 | 1200 | 558 | 308 | 205 |
| W | 6000 | 1700 | 747 | 428 | 282 |
| Full | 15740 | 4310 | 1911 | 1056 | 693 |

PAR12X8A

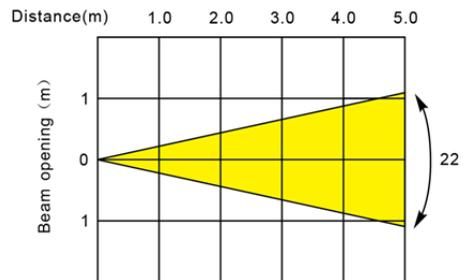

| Diameter(m) | 0.57 | 0.97 | 1.37 | 1.78 | 2.18 |
|-----------------|-------|------|------|------|------|
| Intensity LUX R | 5300 | 1510 | 665 | 383 | 244 |
| G | 6800 | 1930 | 871 | 512 | 342 |
| B | 4100 | 1100 | 490 | 285 | 195 |
| A | 4860 | 1450 | 591 | 365 | 225 |
| Full | 15110 | 4200 | 1920 | 1142 | 757 |

Dimensions

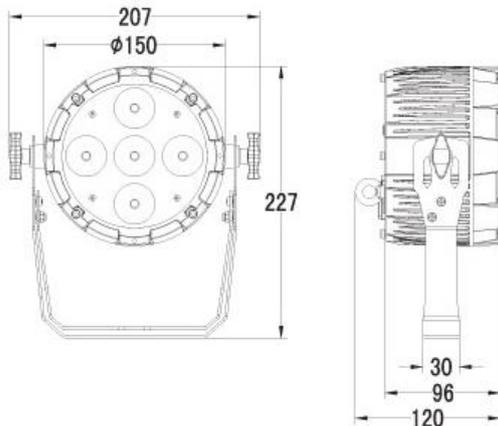

PAR5

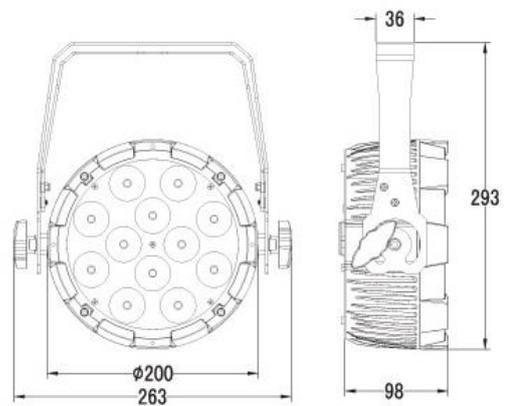

PAR12

CONTROL BOARD OPERATION

| Display | Function |
|----------|---|
| DMX Add | To set DMX address |
| DMX Cha | To set DMX channel modes: CH10, CH06, CH04, CH03, CH02 |
| Dimmer | To set dimmer curve: 01, 02, 03, 04, 05 |
| Sound | To set sound active mode and the sensitivity (Sen000 ~ Sen100) |
| Static C | To set static colors: Static Color RGBW Models - R, G, B, W, GB, RB, RG, RGB, RW, GW, BW, RGW, RBW, GBW, RGBW RGBA Models - R, G, B, A, GB, RB, RG, RGB, RA, GA, BA, RGA, RBA, GBA, RGBA |
| Manual C | To set user mode intensity of each colour separately for color mixing and strobe rate |
| Auto Pro | To set built-in automatic programs (Pr 01 ~ Pr 05) and speed from Sp000 to Sp100 To set sound active mode (Pr 06) and sound sensitivity from Sen000 to Sen100 To set multi fixture chases (Pr 07) |
| Mas/Sla | To set Master/Slave modes |
| Reset | To reset factory default setting |

DMX Addressing:

After select the "DMX Add" and press "Enter", use "Up" and "Down" button to select the desired DMX address press "Enter" to save new setting

DMX Modes

After select the "DMX Cha" and press "Enter", use "Up" and "Down" button to select the desired DMX mode, press "Enter" to save new setting

Dimmer Speed Setting:

After select the "Dimmer" and press "Enter", use "Up" and "Down" button to select the desired dimmer curves,

Sound Mode

Entered "sound" mode, use "Up" and "Down" button to select the sensitivity Sen000-Sen100, press "Enter" to save new setting

Manual Color Mode

Set intensity of each colour separately to get endless color mixing from the control panel with strobe function.

Entered "Manual C" mode, use "Up" and "Down" button to select the each color (RGBW or RGBA) intensity from 000 to 255 and strobe (S) speed from S000 to S100. (S000 is freeze and S001 to 100 is from slow to fast) press "Enter" to save new setting

Setting Static Colour

Entered "Static C" mode, you can select the desired solid color via the "UP" or "DOWN" buttons, press "Enter" to save new setting

| 8W RGBW LED | | 8W RGBA LED | |
|-------------|----------------------------|-------------|----------------------------|
| Value: | Function: | Value: | Function: |
| R | Red | R | Red |
| G | Green | G | Green |
| B | Blue | B | Blue |
| W | White | A | Amber |
| GB | Green + Blue | GB | Green + Blue |
| RB | Red + Blue | RB | Red + Blue |
| RG | Red + Green | RG | Red + Green |
| RGB | Red + Green + Blue | RGB | Red + Green + Blue |
| RW | Red + White | RA | Red + Amber |
| GW | Green + White | GA | Green + Amber |
| BW | Blue + White | BA | Blue + Amber |
| RGW | Red + Green + White | RGA | Red + Green + Amber |
| RBW | Red + Blue + White | RBA | Red + Blue + Amber |
| GBW | Green + Blue + White | GBA | Green + Blue + Amber |
| RGBW | Red + Green + Blue + White | RGBA | Red + Green + Blue + Amber |

Automatic & Sound Mode

This fixture has 7 built-in programs.

Entered "Auto Pro" mode, use "Up" and "Down" button to select the built-in programs "Pr 01 ~ Pr 07" then press the "Enter" to confirm.

Use "Up" and "Down" button to select the operating speed of the program (Value:S000 ~ S100, Freeze, Slow ~ Fast), press "Enter" to save new setting.

| Mode: | Value: | Function: |
|--------------|--------|--|
| Auto Program | Pr 01 | RGBW Model : R G B W colour switching RGBA Model : R G B A colour switching |
| | Pr 02 | 15 colour switching |
| | Pr 03 | RGBW Model : R G B W colour fading RGBA Model : R G B A colour fading |
| | Pr 04 | 15 colour fading |
| | Pr 05 | Color Macros Fading |
| | Pr 06 | Sound active mode |
| | Pr 07 | Multi fixture chases |

To setup sound active mode Pr 06

1. Entered "Auto Pro" mode, use "Up" and "Down" button to select the built-in program "Pr 06", press "Enter" to confirm.
2. Use "Up" and "Down" button to select the sensitivity Sen000 ~ Sen100, press "Enter" to save new setting

To setup multi fixture chases Pr 07

Before starting, go to each fixture and reset the menu to fixture defaults.

1. On the master unit, setup the DMX address to the total number of fixtures in the string. For example, you may have a total of 20 par cans including the master, so the DMX address should be set to "20".
2. On the master unit, go to master/slave menu setting and set the unit to master
3. On the master unit, set the unit to "Auto Mode" "Pr 07" which supports multi fixture chases.
4. On each slave unit, setup the DMX address to the fixture position in the string. For example, if this unit is the 2nd unit in the string including the master, then set the DMX address to 2. If this the last unit of 20, then the DMX address should be set to 20. It is possible to double up fixture positions as well as fixture 1.
5. On each slave, go to the master/slave menu setting and set it to slave.

Master/Slave Operation

1. Set the master fixture to one of the standalone operating modes: automatic, sound, static color or manual color modes
2. Set the slaves, entered "Mas/Sla" mode, set to "S", press "Enter"

DMX Chart

2 channels Mode

| Channel | Value | Function |
|---------|---------|--------------------------|
| 1 | 000-255 | Warm white to cool white |
| 2 | 000-255 | dimmer 0% ~ 100% |

3 channels Mode

| Channel | Value | Function |
|---------|---------|------------------|
| 1 | 000-255 | Red: 0% ~ 100% |
| 2 | 000-255 | Green: 0% ~ 100% |
| 3 | 000-255 | Blue: 0% ~ 100% |

4 channels Mode

| RGBW Channel | Value | Function |
|--------------|---------|--|
| 1 | 000-255 | Red: 0% ~ 100% |
| 2 | 000-255 | Green: 0% ~ 100% |
| 3 | 000-255 | Blue: 0% ~ 100% |
| 4 | 000-255 | RGBW Model : White: 0% ~ 100% RGBA Model : Amber: 0% ~ 100% |

6 channels Mode

| RGBW Channel | Value | Function |
|--------------|---------|--|
| 1 | 000-255 | Red: 0% ~ 100% |
| 2 | 000-255 | Green: 0% ~ 100% |
| 3 | 000-255 | Blue: 0% ~ 100% |
| 4 | 000-255 | RGBW Model : White: 0% ~ 100% RGBA Model : Amber: 0% ~ 100% |
| 5 | 000-255 | Master DIMMER 0% ~ 100% |
| 6 | 000-009 | No function |
| | 010-019 | Sound Active |
| | 020-255 | Strobe : Slow ~ Fast (1~30Hz) |

10 channels Mode

| RGBW Channel | Value | Function |
|--------------|---------------------|--|
| 1 | 000-255 | Red: 0% ~ 100% |
| 2 | 000-255 | Green: 0% ~ 100% |
| 3 | 000-255 | Blue: 0% ~ 100% |
| 4 | 000-255 | RGBW Model : White: 0% ~ 100% RGBA Model : Amber: 0% ~ 100% |
| 5 | 000-255 | Master DIMMER 0% ~ 100% |
| 6 | 000-009 | Strobe OFF |
| | 010-255 | Strobe (slow-fast 1-30Hz) |
| 7 | 000-019 | No Function |
| | 020-039 | RED 100% / GREEN 0% ~ 100% / BLUE 0% |
| | 040-059 | RED 100% ~ 0% / GREEN 100% / BLUE 0% |
| | 060-079 | RED 0% / GREEN 100% / BLUE 0% ~ 100% |
| | 080-099 | RED 0% / GREEN 100% ~ 0% / BLUE 100% |
| | 100-119 | RED 0% ~ 100% / GREEN 0% / BLUE 100% |
| | 120-139 | RED 100% / GREEN 0% / BLUE 100% ~ 0% |
| | 140-159 | RED 100% / GREEN 0% ~ 100% / BLUE 0% ~ 100% |
| | 160-179 | RED 100%~ 0% / GREEN 100% ~ 0% / BLUE 100% |
| | 180-200 | RGBW Model : RED 100% / GREEN 100% / BLUE 100% /WHITE 100% RGBA Model : RED 100% / GREEN 100% / BLUE 100% /AMBER 100% |
| | 201-204 | Color Temperature 1 |
| | 205-209 | Color Temperature 2 |
| | 210-214 | Color Temperature 3 |
| | 215-219 | Color Temperature 4 |
| 220-224 | Color Temperature 5 | |
| 225-229 | Color Temperature 6 | |
| 230-234 | Color Temperature 7 | |

Warm



| | | | |
|----|---------|--|------|
| | 235-239 | Color Temperature 8 | Cool |
| | 240-244 | Color Temperature 9 | |
| | 245-249 | Color Temperature 10 | |
| | 250-255 | Color Temperature 11 | |
| 8 | 000-009 | No Function | |
| | 010-049 | RGBW Model : R G B W colour switching RGBA Model : R G B A colour switching | |
| | 050-090 | 15 colour switching | |
| | 091-131 | RGBW Model : R G B W colour fading RGBA Model : R G B A colour fading | |
| | 132-172 | 15 colour fading | |
| | 173-213 | Color Macros Fading | |
| | 214-255 | Sound active mode | |
| 9 | 000-255 | Speed of auto programs (slow ~ fast) or sound sensitivity | |
| 10 | 000-009 | Use dimmer curve from setting of control board | |
| | 010-057 | 16 bits Linear dimmer 1 | |
| | 058-106 | 16 bits Non-linear dimmer 2 | |
| | 107-155 | 16 bits Non-linear dimmer 3 | |
| | 156-204 | 16 bits Non-linear dimmer 4 | |
| | 205-255 | 8 bits Linear dimmer 5 | |

TECHNICAL SPECIFICATIONS

| Model | PARRGBW5X8 | PAR5X8A | PARRGBW12X8 | PAR12X8A |
|------------------------------|---|--------------|---------------|---------------|
| Dimensions and Weight | | | | |
| Overall size LxWxH (mm) | 207x227x120 | | 263x293x98 | |
| Weight (kg) | 1.9 | | 3.2 | |
| Power | | | | |
| Power Supply | 100~240V AC, 50/60 Hz | | | |
| Power Consumption (w) | 40 | | 98 | |
| Fuse | T 1 A, 250 V | | T 2 A, 250 V | |
| LED | 5pcs 8W RGBW | 5pcs 8W RGBA | 12pcs 8W RGBW | 12pcs 8W RGBA |
| Operation Modes | DMX, auto run, sound active, master/slave, manual colour control, static colour control | | | |
| Beam Angle | 22° | | | |
| Refresh Rate | 2940Hz | | | |
| DMX Channel mode | 2, 3, 4, 6, 10 | | | |
| Power Input | IEC | | | |
| Power Output | No | | IEC | |

WARRANTY

Please refer to your local dealer or please contact Event Lighting Pty Ltd

Website: www.event-lighting.com.au