

M1H420W

420 W LED HYBRID MOVING HEAD WITH CMY, CTO AND ZOOM

The **M1H420W** is a punchy hybrid mover with a 3-facet prism and frost, iris, an 8-colour wheel, fixed and interchangeable rotating gobo wheels and a beam angle of 5° to 50°.

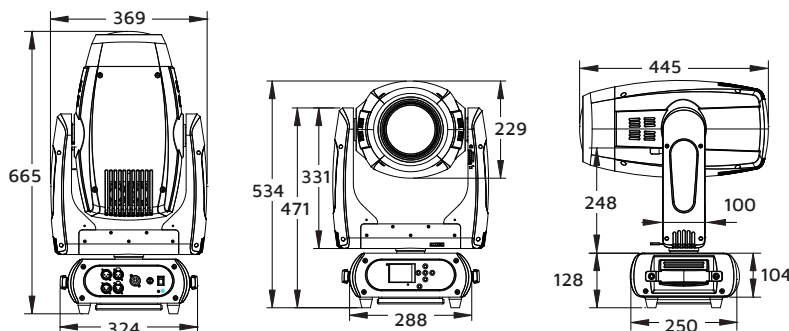

	2.5m	5.0m	7.5m	10.0m
Lux				
@ 5°	Ø0.22	Ø0.44	Ø0.65	Ø0.87
	110,000	27,800	11,600	6,950
@ 50°	Ø2.33	Ø4.66	Ø6.99	Ø9.33
	5,030	1,490	700	622



Photometrics	
Light Source	420 W White LED, 6,500 K
Beam Angle	5°~50°
Output	20,050 lumen, 110,000 lux @ 2.5 m @ 5°
PWM	1,200 Hz
LED Lifespan	20,000 hours
Colour	Linear CMY & CTO
Colour Wheel	8 colours + open
Fixed Gobo	6 + open
Rotating Gobo	7 + open, interchangeable (outside ø27 mm, inside ø20 mm)
Effects	
Dimming	0~100%
Strobe	0.5~26 Hz
Focus	Motorised
Prism	3-facet
Frost	Yes
Iris	Yes
Zoom	Motorised, 5°~50°
Movement	
Pan	8/16-bit auto reposition
Tilt	630° (4.4s)/540° (3.9s)
	233° (2.3s)
Power	
Input Voltage	100~240 V AC, 50/60 Hz, 590 W
Connection	Neutrik® powerCON in
Control	
Operation Modes	DMX, auto, sound active, master/slave
Control Protocol	DMX512, RDM, (optional: W-DMX™)
DMX Channels	19/21/28/29
Control Interface	3-pin XLR, 5-pin XLR
Display	2.4" colour LCD control panel with battery power
Software	Upgradable via DMX
Housing	
Housing Materials	ABS and steel, matte black finish
Cooling	Multi-sensor thermostat controlled variable speed fan
IP Rating	IP20
Net Weight	25 kg
Rigging	2x omega brackets with ¼ turn quick locks
Accessories	
Optional	Road Case: MCASE1LS, MCASE2VLS

Colour wheel



Fixed gobo wheel



Rotating gobo wheel



Prism

