

M1H300W

300 W LED HYBRID MOVING HEAD WITH CMY, CTO AND ZOOM

The **M1H300W** is a versatile hybrid mover with a 3-facet prism and frost, iris, an 8-colour wheel, fixed and interchangeable rotating gobo wheels and a beam angle of 6° to 48°.

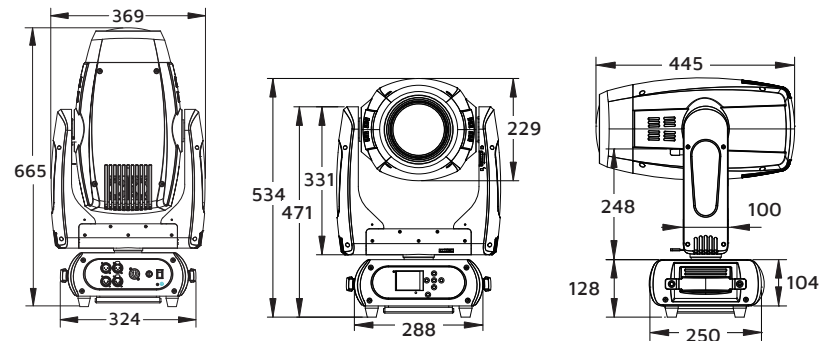

Photometrics	
Light Source	300 W White LED, 6,500 K
Beam Angle	6°~48°
Output	18,000 lumen, 89,700 lux @ 2.5 m @ 6°
PWM	1,200 Hz
LED Lifespan	60,000 hours
Colour	Linear CMY & CTO
Colour Wheel	8 colours + open
Fixed Gobo	7 + open
Rotating Gobo	7 + open, interchangeable (outside ø27 mm, inside ø20 mm)
Effects	
Dimming	0~100%
Strobe	0.5~26 Hz
Focus	Motorised
Prism	3-facet
Frost	Yes
Iris	Yes
Zoom	Motorised, 6°~48°
Movement	
Pan	8/16-bit auto reposition
Tilt	630° (4.0s)/540° (3.58s)
Tilt	265° (2.8s)
Power	
Input Voltage	100~240 V AC, 50/60 Hz, 400 W
Connection	Neutrik® powerCON in
Control	
Operation Modes	DMX, auto, sound active, master/slave
Control Protocol	DMX512, RDM, (optional: W-DMX™)
DMX Channels	19/21/28/29
Control Interface	3-pin XLR, 5-pin XLR
Display	2.4" colour LCD control panel with battery power
Software	Upgradable via DMX
Housing	
Housing Materials	ABS and steel, matte black finish
Cooling	Multi-sensor thermostat controlled variable speed fan
IP Rating	IP20
Net Weight	18 kg
Rigging	2x omega brackets with ¼ turn quick locks
Accessories	
Optional	Road Case: MCASE1LS, MCASE2VLS

Lux				
	2.5m	5.0m	7.5m	10.0m
@ 6°	Ø0.26	Ø0.52	Ø0.79	Ø1.05
	89,700	22,550	10,190	5,811
@ 48°	Ø2.23	Ø4.45	Ø6.68	Ø8.90
	4,230	1,419	640	406

Colour wheel



Fixed gobo wheel



Rotating gobo wheel



Prism

