

# M1H250W

## 250 W LED HYBRID MOVING HEAD WITH ZOOM

The **M1H250W** is a compact hybrid mover with a 3-facet prism and frost, iris, an 8-colour wheel, fixed and interchangeable rotating gobo wheels and a beam angle of 7.5° to 40°.

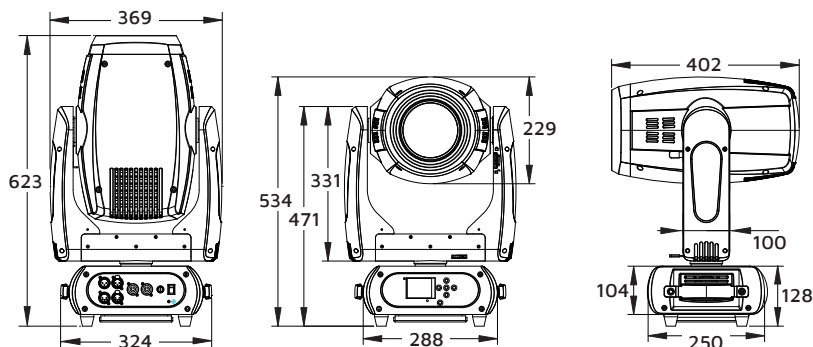

Lux			
	3.0m	5.0m	7.5m
@ 7.5°	Ø0.44	Ø0.75	Ø1.00
	57,000	20,000	9,098
@ 40°	Ø2.16	Ø3.82	Ø4.98
	2,750	1,000	9,067



Photometrics	
Light Source	250 W White LED, 8,000 K
Beam Angle	7.5°~40°
Output	6,239 lumen, 57,000 lux @ 3 m @ 7.5°
PWM	1,200 Hz
LED Lifespan	60,000 hours
Colour	Linear CMY & CTO
Colour Wheel	8 colours + open
Fixed Gobo	7 + open
Rotating Gobo	7 + open, interchangeable (outside ø27 mm, inside ø20 mm)
Effects	
Dimming	0~100%
Strobe	0.5~26 Hz
Focus	Motorised
Prism	3-facet
Frost	Yes
Iris	Yes
Zoom	Motorised, 7.5°~40°
Movement	
Pan	8/16-bit auto reposition
Tilt	630° (4.3s)/540° (3.9s)
Tilt	233° (2.2s)
Power	
Input Voltage	100~240 V AC, 50/60 Hz, 277 W
Connection	Neutrik® powerCON in/out
Control	
Operation Modes	DMX, auto, sound active, master/slave
Control Protocol	DMX512, RDM, (optional: W-DMX™)
DMX Channels	15/17/24/25
Control Interface	3-pin XLR, 5-pin XLR
Display	2.4" colour LCD control panel with battery power
Software	Upgradable via DMX
Housing	
Housing Materials	ABS and steel, matte black finish
Cooling	Multi-sensor thermostat controlled variable speed fan
IP Rating	IP20
Net Weight	20 kg
Rigging	2x omega brackets with ¼ turn quick locks
Accessories	
Optional	Road Case: MCASE1LS, MCASE2VLS

### Colour wheel



### Fixed gobo wheel



### Rotating gobo wheel



### Prism

