

F200IIFC

200W Full Colour Fresnel with Zoom

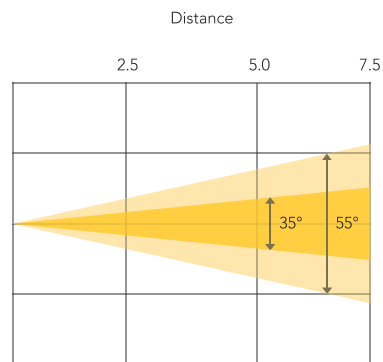
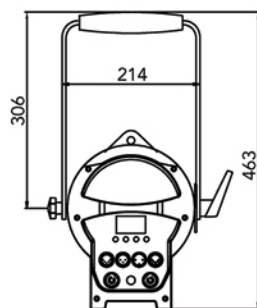
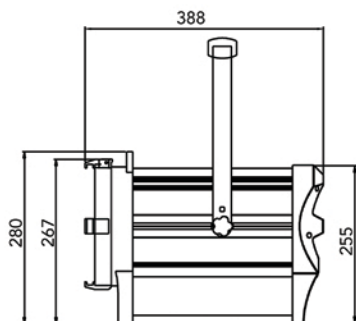

| LUX @ 35° | ∅ 0.70 | ∅ 1.40 | ∅ 2.10 |
|-----------|--------|--------|--------|
| R | 300 | 75 | 35 |
| G | 340 | 86 | 39 |
| B | 81 | 21 | 9 |
| CW | 1,630 | 407 | 180 |
| WW | 300 | 75 | 34 |
| A | 172 | 43 | 20 |
| L | 387 | 98 | 43 |
| Full | 3,235 | 809 | 360 |

| LUX @ 55° | ∅ 1.11 | ∅ 2.22 | ∅ 3.33 |
|-----------|--------|--------|--------|
| R | 271 | 68 | 30 |
| G | 326 | 82 | 37 |
| B | 70 | 18 | 8 |
| CW | 1,160 | 290 | 129 |
| WW | 229 | 57 | 26 |
| A | 162 | 40 | 18 |
| L | 322 | 82 | 36 |
| Full | 2,535 | 634 | 282 |

MODEL F200IIFC

Description 200W Full Colour
Fresnel with Electronic Zoom
Series Fresnel

POWER

Power Consumption 200W
Input Voltage 100 – 240V AC 50 / 60Hz
Power Connection Seetronic® True 1 In / Out

PHOTOMETRICS

Light Source 200W RGBACWL
RGBA: 3 LEDs Each
CW: 12 LEDs
WW: 6 LEDs
L: 6 LEDs
Output (@2.5M at 35°) 3,235 lux
Output (@2.5M at 55°) 2,535 lux
Beam Angle 35° to 55°
Field Angle 40° to 75°
Lens 120 mm Fresnel
PWM 8,000 Hz
LED Lifespan 50,000 hours

EFFECTS

Dimming 0 - 100%, 8-bit / 16-bit
Dimming Curves 3
Strobe 1 Hz - 25 Hz
Zoom Electronic Linear 35° - 55°
Barn Door Included
Gel Frame Included

CONTROL

Operation DMX, Manual & Master / Slave
Display 4-Button LCD Control Panel
DMX Protocol DMX512
DMX Channels 8
DMX Interface 3-Pin & 5-Pin XLR

HOUSING

Housing Materials & Finish Matte Black Die-cast Aluminium
Cooling Sensor Thermostat
Controlled Variable
Speed Fan
Dimension (mm) 388 X 214 X 463
Net Weight (kg) 8.5

