

AeroPilates®

THE STAND

Medium



for use with the following 3 and 4 cord AeroPilates reformers

AeroPilates 435 (SPPP-AEJP4-435)

AeroPilates 4300 (SPPP-AEJP-WB)

AeroPilates JP 295 (SPPP-AEJP-CB)

AeroPilates 4240 (SPPP-AEJP-4240)

AeroPilates 272 (SPPP-AE272)

Assembly & User Manual

model: SPPP-STAND-JP
reference no. 55-4050U

Parts List

PART NO.	PART NAME	QTY
1	Front Stand	1
2	Middle Stand	1
3	Rear Stand	1
4	Connection Bar	4
5	Endcap	6
6	Pull Pin	8
7	Manual (not shown)	1

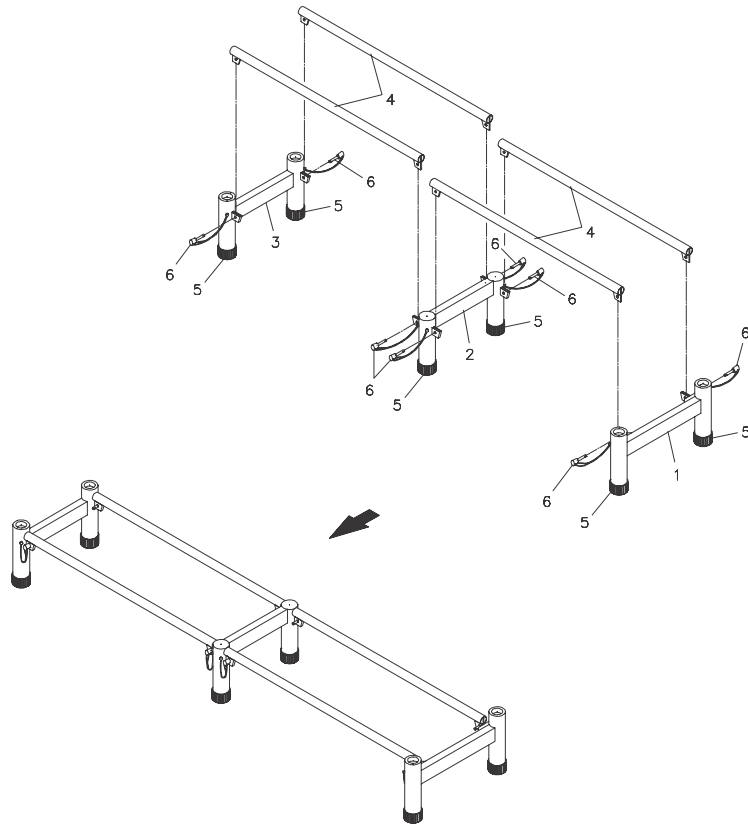

Before You Start

These instructions should be used in conjunction with the main AeroPilates reformer Assembly and User Manual

Assembly

Assemble in a clean, clear area. Give yourself plenty of space to easily move around the product as this will reduce your chance of getting injured while assembling. You might also find it quicker and safer if you work with a friend when handling large parts.

The stand is designed for elevating your reformer on a semi-permanent basis. The stand and reformer should be used where there is sufficient space to leave assembled between uses. The stand can be dismantled for long term storage.

Check you have everything

Carefully unpack each component and check that you have all the parts against the parts list before starting to assemble your product. Remember a number of parts will be factory fitted to the larger component. If any are missing please contact our Customer Care staff for assistance.

Storage and Use

This product is designed for indoor use in clean dry conditions. Do not store in cold or damp conditions as this may cause corrosion.

Safety

- Make sure that all locking pins are secure before use.
- Do not exercise at an intensity that causes the product to move. This could result in damage to joints and the product.
- Setup on a level surface. Do not position on loose rugs or uneven surfaces.
- Tighten/replace loose or worn components prior to use.
- Choose a workout which best fits your physical strength/flexibility level. Use common sense while exercising.
- Injuries may result from incorrect or excessive exercise.
- Keep all children and pets away from the product at all times including while using or while assembling.
- Be careful to maintain your balance while using, mounting, dismounting, or assembling the product. Loss of balance may result in a fall and serious bodily injury. Do not perform the 'abdominal oblique side twist exercises' when using the stand.
- Please use this product one person at a time.
- Ensure a free space of 3.5m x 2.0m is available before use.

Weight Limit

This product is suitable for users weighing 300lbs/21.5 stones/136kg or less.

Specification

Classification: Class H – indoor use only

Assembled foot print: 2.20m x 0.50m

Product weight: 13.1kg

Assembly

Connect the **Front Stand(1)** to the **Middle Stand(2)** with two **Connection Bars(4)** and lock into place with the **Pull Pins(6)**. Connect the **Rear Stand(3)** to the **Middle Stand(2)**.

Note: The feet of the Pilates machines must fit into the **Front Stand(1)** and the **Rear Stand(3)**. The **Front Stand(1)** is wider than the **Rear Stand(3)**. The Foot Rest end of your Pilates machine will fit into the top of the **Front Stand(1)** and the Headrest of your Pilates machine will fit into the **Rear Stand(3)**.

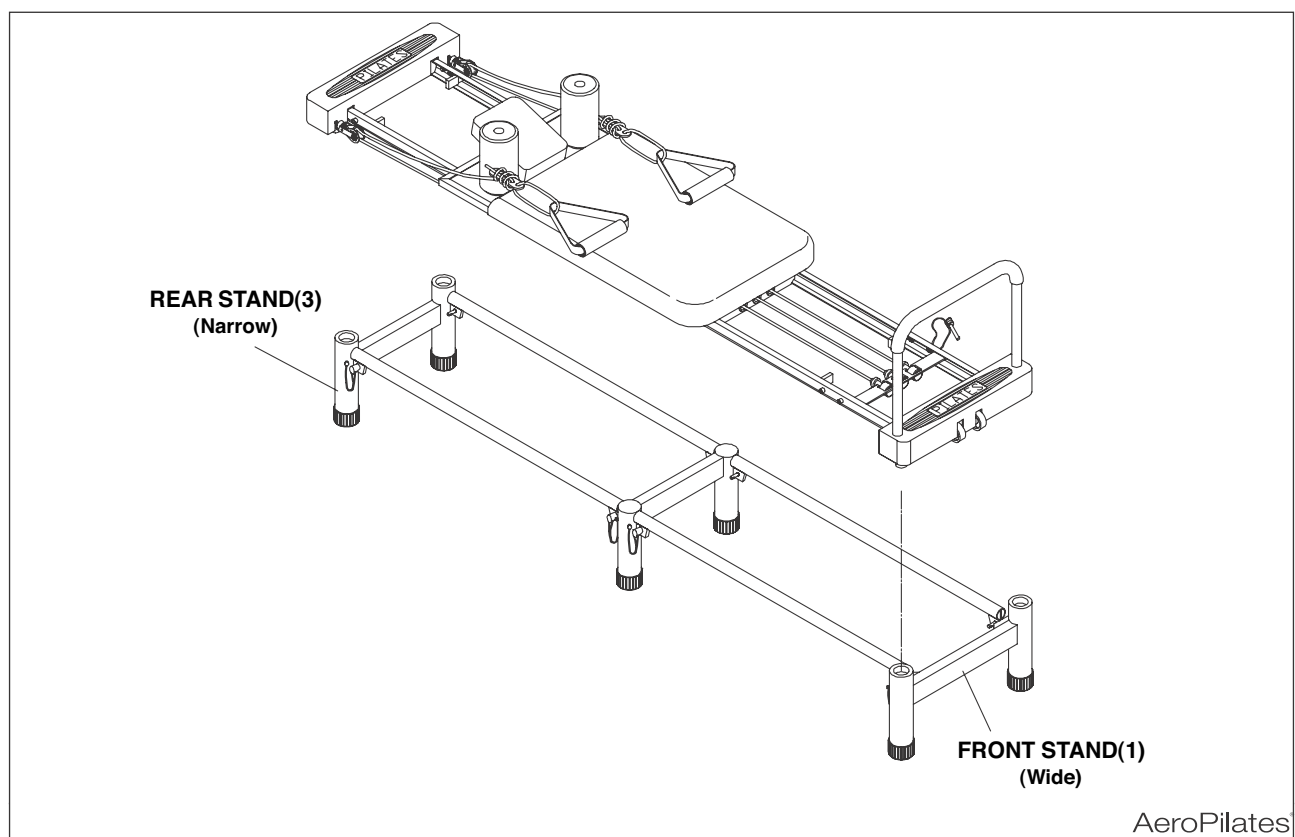

Fax/Mail Ordering Form

Please do not return the product. For your convenience, The Dezac Group Limited has a Customer Service Department. Should a part be missing or a defective part found, please call **+44 (0)1242 702345** between 9.00am and 5.00pm on Monday to Friday or fill out the fax sheet ordering form below and fax it to +44 (0)1242 702301. Our Customer Service Department will be able to assist you with your problem and the part will be mailed directly to your house.



TELEPHONE
CUSTOMER SERVICE
Tel: +44 (0)1242 702345



FAX
CUSTOMER SERVICE
Fax: +44 (0)1242 702301



ONLINE
CUSTOMER SERVICE
online@riobeauty.com
or
www.riobeauty.com



MAIL
THE DEZAC GROUP LTD
P.O. Box 17
Cheltenham
Glos. GL53 7ET

Detach and Mail or Fax the Form Below

THE DEZAC GROUP LTD P.O. BOX 17, CHELTENHAM, GLOUCESTERSHIRE GL53 7ET

Name:

Address:

..... Post Code:

IMPORTANT: We must have your phone number in order to process the order!

Daytime number: Evening number:

Date Purchased: Model number: SPPP-STAND-JP

Purchased From:

**IMPORTANT: Before filling out the form below make sure you have the right information.
Refer to the 'Parts List' to make sure you're ordering the right parts!**

PART #	DESCRIPTION	QUANTITY
EXAMPLE: 1	Front Stand	1

YOUR TWO YEAR GUARANTEE

On receipt of the completed guarantee registration slip below, The Dezac Group Limited will guarantee this product for two years against failure due to faulty workmanship or components. Please complete in block capitals.

Model: The Stand Medium Date of purchase: _____ Purchased from: _____

Name: _____

Address: _____

Country: _____ Post Code: _____

Email: _____

Cut out and send completed form to: The Dezac Group Ltd, PO Box 17, Cheltenham, Glos, GL53 7ET, England