

SANITAS

SEM 43



SANITAS

CE 0483

D	Gebrauchsanweisung <i>Digital EMS/TENS</i>	3
GB	Instruction for use <i>Digital EMS/TENS unit</i>	16
F	Mode d'emploi <i>Appareil EMS/TENS numérique</i>	28
I	Instruzioni per l'uso <i>Apparecchio EMS/TENS digitale</i>	41
RUS	Инструкция по применению <i>Цифрового прибора EMS/TENS</i>	54

 Serviceadresse:
Hans Dinslage GmbH
Riedlinger Straße 28
88524 Uttenweiler, GERMANY
Tel.-Nr.: +49 (0) 7374-915766
Fax-Nr.: +49 (0) 7374-920723
E-Mail: service@sanitas-online.de

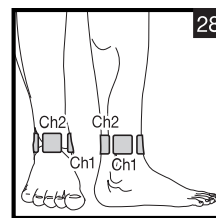
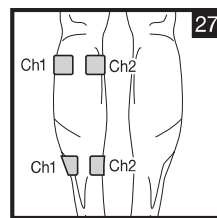
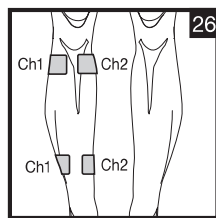
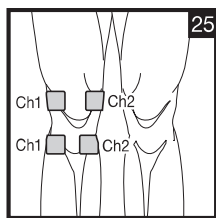
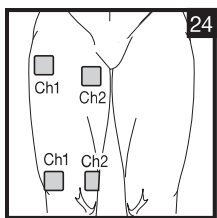
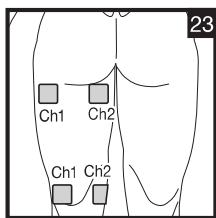
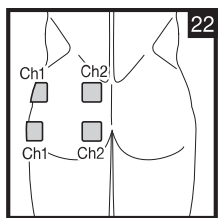
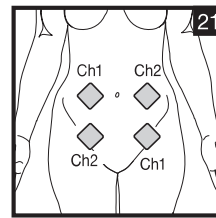
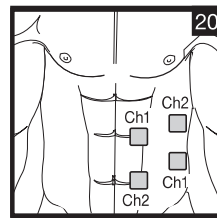
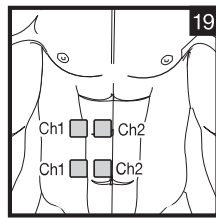
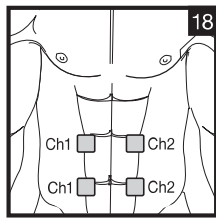
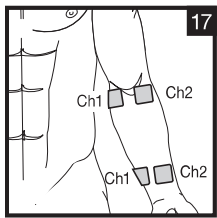
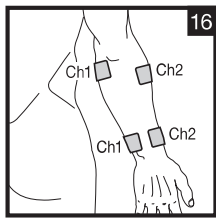
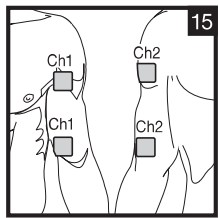
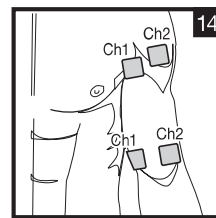
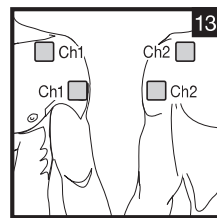
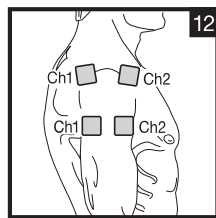
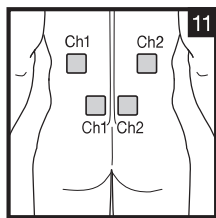
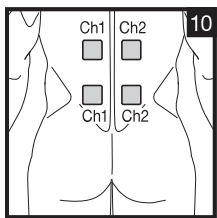
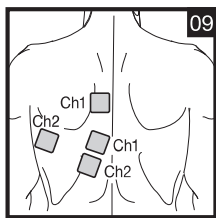
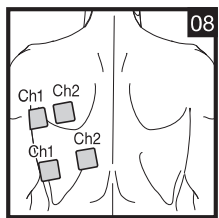
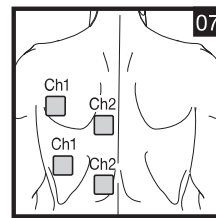
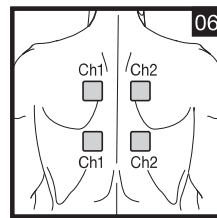
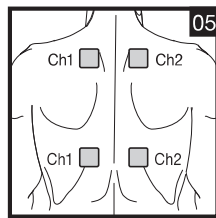
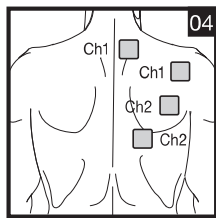
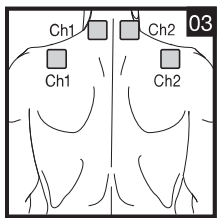
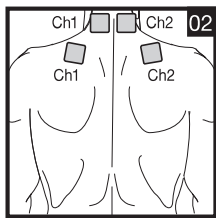
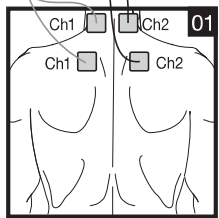
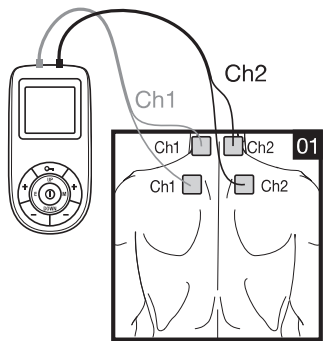

ENGLISH

Table of Contents

1. Getting to know your machine	16
1.1 What is Digital EMS/TENS and what can it do?.....	16
1.2 Scope of supply	17
2. Important Information	17
3. Current parameters	19
3.1 Pulse shape	19
3.2 Pulse frequency.....	19
3.3 Pulse width	19
3.4 Pulse intensity	19
3.5 Cycle-controlled pulse parameter variation	19
4. Unit description	20
5. Start-up	20
6. Programme overview	21
6.1 Basic information	21
6.2 Information on placing the electrodes	21
6.3 TENS program table	22
6.4 EMS program table	22
6.5 MASSAGE program table	23
7. Application	23
7.1 Advice on application.....	23
7.2 Procedure for programs TENS 1–7, EMS 1–27 and MASSAGE 1–10 (quick start)	23
7.3 Setting individual parameters.....	24
7.4 Changes to the settings	25
7.5 Doctor's Function.....	25
8. Cleaning and storage	26
9. Disposal	26
10. Problems and solutions	26
11. Technical details	27

Please read these instructions for use carefully and keep them for later use, be sure to make them accessible to other users and observe the information they contain.

1. Getting to know your machine

1.1 What is Digital EMS/TENS and what can it do?

Digital EMS/TENS belongs to the group of electrical stimulation systems. It has three basic functions, which can be used in combination:

1. Electrical stimulation of nerve tracts (TENS).
2. Electrical stimulation of muscle tissue (EMS).
3. A massage effect generated by electrical signals.

For this, the device has two independent stimulation channels and four self-adhesive electrodes. It has various versatile functions in order to increase general wellbeing, alleviate pain, maintain physical fitness, relaxation, revitalise muscles and combat fatigue. You can either select these functions from preset programmes or determine them yourself according to your requirements.

The operating principle of electrical stimulation equipment is based on simulating the body's own pulses which are transmitted transcutaneously to nerve or muscle fibres by means of electrodes. The electrodes can thereby be attached to many parts of the body, whereby the electrical stimuli are safe and practically painless. You merely feel a gentle prickling or vibrating in some applications. The electrical pulses transmitted to the tissue affect the transmission of stimulation in nerve conductions as well as neural nodes and muscle groups in the field of application.

The effect of electrical stimulation is generally only recognisable after regularly repeated application. Electrical stimulation does not replace regular exercising of the muscle, but is able to reasonably supplement the effect thereof.

TENS, transcutaneous electrical nerve stimulation, means electrical stimulation of nerves through the skin. TENS is recognised as a clinically proven, effective, non-medication method of treating pain from certain causes. It is free from side-effects when used properly, and can also thereby be used as a simple means of self-treatment. The pain-alleviating or suppressing effect is also achieved by preventing pain from being passed on into nerve fibres (above all through high-frequency pulses) and increasing the secretion of the body's own endorphines which reduce awareness of pain through their effect on the central nervous system. The method is scientifically underpinned and medically approved.

Any symptoms indicating TENS application must be clarified with the doctor in charge of your treatment. The latter will also give you information on the respective benefits of TENS self-treatment.

TENS is clinically tested and approved with the following applications:

- Back pain, particularly also lumbar and cervical spine problems
- Joint pain (e.g. knee joint, hip joint, shoulder)
- Neuralgia
- Headaches
- Women's period pains
- Pain after injuries to musculoskeletal system
- Pain with circulatory problems
- Chronic pain through various causes

Electrical muscle stimulation (EMS) is a widespread and generally recognised method and has been used for years in sports and rehabilitation medicine. In the sports and fitness field, one of the uses of EMS is as a supplement to conventional muscle training, in order to increase the efficiency of muscle groups and adapt physical proportions to the desired aesthetic results. EMS application goes in two directions. On the one hand, a targeted strengthening of musculature can be produced (activating application) and on the other hand a relaxing, resting effect can also be achieved (relaxing application).

Active application includes the following:

- Muscle training to improve endurance performance and/or
- Muscle training to support the strengthening of certain muscles or muscle groups in order to achieve desired changes to body proportions.

Relaxing application includes the following:

- Muscle relaxation in order to loosen up muscular tension
- Improving muscular fatigue symptoms
- Accelerating muscle regeneration after high muscular performance (e.g. after a marathon).

Through **integrated massage technology**, Digital EMS/TENS also offers the possibility of reducing muscular tension and combating fatigue symptoms using a programme based on real massage in terms of sensation and effect.

Using the positioning suggestions and programme charts in this manual, you can determine the machine setting fast and easily for the respective application (depending on the region of the body affected) in order to ensure the desired effect.

Through the two separately adjustable channels, the Digital EMS/TENS has the advantage of adapting the intensity of the pulses independently of each other to two parts of the body to be treated, for example in order to cover both sides of the body or ensure even stimulation of larger areas of tissue. The individual intensity setting of each channel also allows you to treat two different parts of the body at the same time, whereby it is possible to save time compared with individual sequential treatment.

1.2 Scope of supply

- 1x Digital EMS/TENS machine (incl. belt clip)
- 2x connecting cable
- 4x adhesive electrodes (45 x 45 mm)
- 3x AAA batteries
- these instructions for use

Subsequent purchase articles

- 8x adhesive electrodes (45 x 45 mm), Art. no. 661.22
- 4x adhesive electrodes (50 x 100 mm), Art. no. 661.21

2. Important Information

Use of the machine does not replace medical consultation and treatment. In the event of any type of pain or illness, you must therefore always first ask your doctor.

WARNING!

In order to prevent any damage to health, we would urgently advise against using the Digital EMS/TENS in the following cases:

- With any implanted electrical devices (such as pacemakers)
- If there are any metal implants
- When using an insulin pump
- In case of high fever (e.g. >39 °C)
- In case of known or acute cardiac arrhythmias and other disorders in stimulus formation and conduction of the heart
- If suffering from attacks (e.g. epilepsy)
- If pregnant
- In case of cancer
- After operations where increased muscle contractions might impair the healing process



- Never use near the heart. Stimulation electrodes should never be placed anywhere on the front of the thorax (marked by ribs and breastbone), but above all not on the two large pectoral muscles. Here it can increase the risk of ventricular fibrillation and lead to cardiac arrest
- On the bony part of the cranium, near the mouth, throat or larynx
- Near the throat/carotid artery
- Near the genitals
- On acutely or chronically diseased (injured or inflamed) skin (e.g. in the event of painful and painless inflammation, reddening, skin rashes (e.g. allergies), burns, bruises, swellings, open wounds and wounds in the process of healing, on operation scars in the process of healing)
- In environments with high humidity such as in the bathroom or when having a bath or shower
- Do not use after consuming alcohol
- When a high frequency surgical device is connected at the same time

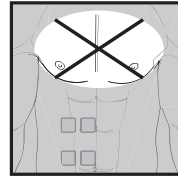

Before using the machine, you should consult with the doctor in charge of your treatment in the event of the following:

- Acute diseases, especially if hypertension is suspected or actually exists, or blood-clotting disorders, tendency to thromboembolic diseases or in case of malignant new masses
- All skin diseases
- Chronic pain disorders which have not been clarified, regardless of the region of the body
- Diabetes
- All sensitivity disorders with reduced pain awareness (such as metabolic disturbances)
- Medical treatments carried out simultaneously
- Complaints arising as a result of the stimulation treatment
- Constant skin irritation as a result of prolonged stimulation at the same electrode point

⚠ IMPORTANT!

Use the Digital EMS/TENS solely:

- On humans
- For the purpose for which it was developed and in the manner specified in these instructions for use. Any improper use can be hazardous.

- For external application.
- With the original accessory parts which are supplied and can be re-ordered, otherwise the warranty becomes null and void.

PRECAUTIONARY MEASURES:

- Always remove the electrodes from the skin with a moderate pull in order to avoid injury in the event of highly sensitive skin.
- Keep the machine away from heat sources and never use it near (~1 m) short-wave or microwave equipment (e.g. mobile phones), as this may lead to unpleasant current spikes.
- Do not expose the machine to direct sunlight or high temperatures.
- Protect the machine from dust, dirt and humidity. Never submerge the device in water or other liquids.
- The machine is suitable for private use.
- For reasons of hygiene, the electrodes should only be used on one person.
- If the machine is not functioning properly, or if you start feeling unwell or there is any pain, stop the application immediately.
- To remove or move the electrodes, first switch off the machine or the appropriate channel in order to avoid unwanted irritation.
- Never modify any electrodes (e.g. by cutting). This leads to a higher current density and can be dangerous (max. recommended output value for electrodes: 9 mA/cm², an effective current density over 2 mA/cm² requires greater attention).
- Do not use when asleep, when driving a vehicle or at the same time as operating machinery.
- Never use with any activities where an unforeseen reaction (e.g. increased muscle contraction despite low intensity) may be dangerous.
- Make sure that no metallic objects such as belt buckles or necklaces can come in contact with the electrodes during stimulation. If you wear any jewellery or piercings (e.g. belly piercing) near the application site, you must remove these before using the machine as burning may otherwise occur at some points.
- Keep the device away from children to prevent any hazards.
- Do not confuse the electrode cables and contacts with your headphones or other devices, and do not connect the electrodes to other devices.
- Do not use this machine at the same time as other equipment which sends electrical pulses to your body.
- Do not use it near any highly flammable substances, gases or explosives.
- Never use accumulators, always use the same types of battery.

- In the initial minutes, carry out the application sitting or lying down in order to avoid any unnecessary risk of injury in the rare event of a vagal reaction (feeling of weakness). If you start feeling weak, switch the machine off immediately and put your legs up (approx. 5–10 minutes).
- It is not advisable to apply any enriching creams or ointments to the skin beforehand, as this greatly increases electrode wear or else unpleasant current spikes may occur here.

Damage

- If the device is damaged, do not use it and contact your retailer or the specified Customer Services address.
- Check the device at regular intervals for signs of wear or damage. If you find any such signs or if the device was used improperly, you must bring it to the manufacturer or dealer before it is used again.
- Switch off the device immediately if it is defective or if it is not working properly.
- Do not, under any circumstances, attempt to open or repair the machine yourself! Only have repairs carried out by the customer service department or an authorized dealer. If these instructions are not heeded, the warranty becomes null and void.
- The manufacturer assumes no liability for damage caused through improper or wrong use.

3. Current parameters

Electrical stimulation machines operate with the following current settings, which will alter the stimulation effect depending on the setting.

3.1 Pulse shape

This describes the time function of the excitation current whereby monophasic pulse trains are differentiated from biphasic. With monophasic pulse trains, the current flows in one direction. With biphasic pulses, the excitation current alternates its direction.

In the Digital EMS/TENS unit, there are only biphasic pulse trains, as they reduce the strain on the muscle, leading to less muscle fatigue as well as safer application.

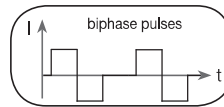
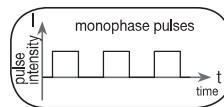

3.2 Pulse frequency

Frequency indicates the number of individual pulses per second, and is indicated in Hz (Hertz). It can be calculated by working out the inverse value of the periodic time. The

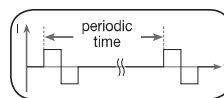

respective frequency determines which types of muscle fibre preferably react. Slow-response fibres tend to react to lower pulse frequencies up to 15 Hz, while fast-response fibres only respond to frequencies over approx. 35 Hz. With pulses of approx. 45–70 Hz, there is permanent tension in the muscle combined with premature muscle fatigue. Higher pulse frequencies can therefore preferably be used for elasticity and maximum strength training.

3.3 Pulse width

Pulse width is used to indicate the duration of an individual pulse in microseconds. Pulse width also determines the penetration depth of the current whereby in general, the following applies: a greater muscle mass requires a greater pulse width.

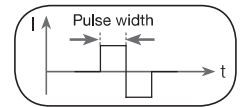

3.4 Pulse intensity

Setting the degree of intensity is individually dependent on the subjective feeling of each individual user and is determined by a number of parameters such as application site, skin circulation, skin thickness as well as quality of electrode contact. The actual setting should be effective but should never produce any unpleasant sensations such as pain at the site of application. While a slight tingling sensation indicates sufficient stimulation energy, any setting which leads to pain must be avoided.

With prolonged application, readjustment may be necessary due to time adjustment processes at the site of application.

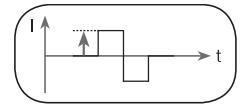



3.5 Cycle-controlled pulse parameter variation

In many cases it is necessary to cover the entirety of tissue structures at the site of application by using several pulse parameters. With the Digital EMS/TENS unit, this is done by the existing programmes automatically making a cyclical pulse parameter change. This also prevents individual muscle groups at the site of application from getting tired.

With the Digital EMS/TENS unit there are useful presettings for current parameters. With this, you can change the impulse intensity at any time during use. For 6 programs you can also set various parameters for stimulation yourself.

4. Unit description

Buttons:

- 1 ON/OFF button 
- 2 **E** button (Enter)
- 3 Intensity setting buttons (**Ch1 +/-** left, **Ch2 +/-** right)
- 4 Keylock 
- 5 Selection button **UP** and **DOWN**
- 6 **M** button (Menu)

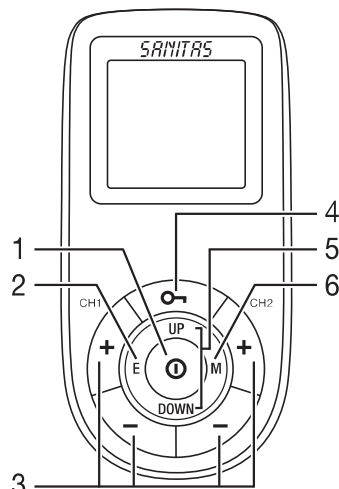

Display (full screen):

- 1 Menu **TENS** / **EMS** / **MESSAGE**
- 2 Low battery
- 3 Keylock
- 4 Timer function (remaining time display) or working time
- 5 Frequency display (Hz), pulse width (μ s) or pause time
- 6 Impulse intensity channel 1 (**Ch1**)
- 7 Impulse intensity channel 2 (**Ch2**)
- 8 Operating status display
- 9 Program number

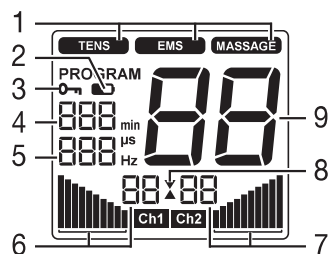

Accessories:

- 2x connection cable
- 4x adhesive electrodes (45 x 45 mm)
- 1x belt clip

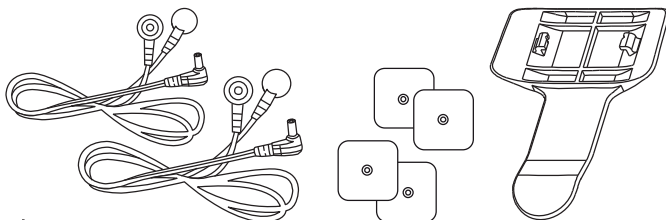

Key functions

Every time a key is pressed, this is acknowledged by a signal tone in order to ensure that any unintentional pressing of a key is detected. This signal tone cannot be switched off.

ON/OFF

- (1) Press briefly to switch the device on.
- (2) Press once to interrupt stimulation treatment.
- (3) Hold ON/OFF key  down (approx. 2 seconds) to switch off the machine.

UP and DOWN

Choice of treatment program, treatment time, frequency, pulse width, working time and pause time.

M (Menu)

- (1) Navigation between **TENS**, **EMS** and **MESSAGE** menus.
- (2) Return to program selection screen or menu selection.

E (Enter)





- (1) Menu selection.
- (2) To confirm a selection made with **UP/DOWN**, apart from channel intensity.

Intensity setting buttons (**Ch1 +/-** left, **Ch2 +/-** right)

Setting pulse intensity.

Keylock

Locks the buttons to avoid them being pressed unintentionally.

- (1) To activate the keylock, hold down the  button until the  symbol is visible in the display (approx. 3 seconds).
- (2) To deactivate the keylock, hold down the  button until the  symbol disappears from the display (approx. 3 seconds).

5. Start-up

1. Remove the belt clip from the machine, if attached.
2. Press the battery compartment cover on the rear of the device and slide it downwards.
3. Insert three AAA 1.5V alkaline batteries. Make absolutely sure that you insert the batteries with the correct polarity as marked.
4. Replace the battery cover carefully (Fig. 1).
5. Reattach the belt clip, if required.
6. Attach the connecting cable to the electrodes (Fig. 2).



The electrodes have a clip fastener to ensure easy connection.

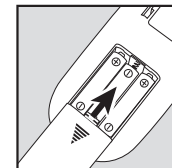

Fig. 1

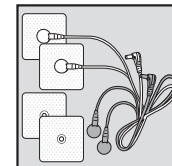

Fig. 2

7. Guide the connection cable plugs into the socket on the top of the device (Fig. 3).
8. Do not pull, twist or make any sharp kinks in the cables (Fig. 4).

i Please note that when the battery is replaced or removed, all settings are restored to the factory default settings.

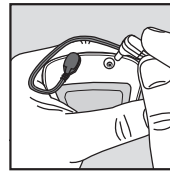

Fig. 3

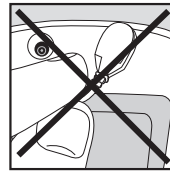

Fig. 4

6. Programme overview

6.1 Basic information

The Digital EMS/TENS unit has a total 50 programmes:

- 10 TENS programmes
- 30 EMS programmes
- 10 MASSAGE programmes

In all programs you can set the impulse intensity of both channels individually. You can also set various parameters in the TENS programs 8–10 and the EMS programs 28–30 to adjust the stimulating effect to the application area.

6.2 Information on placing the electrodes

For the desired success of any stimulation application, it is important that electrodes are placed sensibly.

We advise you to coordinate with your doctor regarding the best electrode positions for your intended field of application.

The electrode positions suggested inside the cover (Figs. 1–28) serve as a guide. The following applies when choosing electrode positions:

Electrode distance

The greater the electrode distance which is selected, the greater will be the volume of tissue that is stimulated. This applies to the area and the depth of the tissue volume. At the same time, however, the strength of tissue stimulation decreases as the electrode distance becomes greater, which means that, if a greater electrode distance is chosen, a greater volume is stimulated, but stimulation is weaker. To increase stimulation, pulse intensity must then be increased.

The following guideline holds when selecting electrode distances:

- most reasonable distance: approx. 5–15 cm,
- below 5 cm, it is mainly surface structures which are strongly stimulated,
- over 15 cm, large-area and deep structures are stimulated very weakly.

Electrode relationship to muscle fibre orientation

Choice of current flow direction must be adapted to the muscle fibre orientation according to the desired muscle layer. If surface muscles are to be reached, the electrodes must be placed parallel to the fibre orientation (A–B/C–D). If deep tissue layers are to be reached, the electrodes must be placed crosswise to the fibre orientation. The latter arrangement can, for example, be achieved via the cross electrode arrangement, e.g. A–D/B–C.

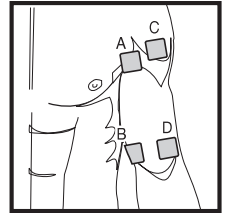

Note the colour-codes of the cables and the channels. The white cable belongs to channel CH1 and the grey cable to channel CH2.

i In the treatment of pain (TENS) using the Digital EMS/TENS machine with its 2 separately controllable channels and in each case 2 adhesive electrodes, it is advisable to either position the electrodes of one channel so that the pain spot lies between the electrodes or else you position one electrode directly on the pain spot and the other at least 2–3 cm away.

The electrodes of the second channel can be used to treat other pain spots simultaneously or else, however, together with the electrodes of the first channel, to surround the pain area (opposite). A cross arrangement is again advisable here.

i Massage function tip: always use all 4 electrodes to ensure optimal treatment.

i In order to extend the durability of the electrodes, use them on clean skin which is as free as possible from hair and grease. If necessary, clean the skin with water before application and remove the hair.

i If an electrode should come loose during use, the impulse intensity of the corresponding channel is reduced to the lowest level. Apply the electrode again and reset the desired impulse intensity.

6.3 TENS program table

Prog. No.	Reasonable areas of application Indications	Phase	Running time (minutes)
1	Pain relief – acute pain	1	30
2	Pain relief – chronic pain (pulse width modulated)	1	30
3	Endorphin effect (burst)	1	30
4	Sciatica	1	30
5	Atrophy treatment	1	05
		2	15
6	Lumbago	1	20
		2	20
7	Periarthritis	1	15
		2	10

i The TENS 8–10 programme can be set individually, see 7.3.2 (p. 24).

Note: Electrode position is supposed to surround the painful area. With painful muscle groups, the electrodes are grouped round the muscle affected. In case of joint pain, the joint on the front/rear side of the joint and, if electrode distances permit, on the right and left sides of the joint, should be surrounded with electrodes.

Minimal electrode distance should not be less than 5 cm and not exceed 15 cm. See figure no. 25 and 28 for knee and ankle joint.

Burst programmes are suitable for all sites which should be treated with an alternating signal pattern (to ensure minimum habituation).

6.4 EMS program table

Prog. No.	Reasonable areas of application Indications	Possible electrode position	Phase	Running time (minutes)
1	Capillarisation	1–28	1	20
2	Warming up	1–28	1	10
3	Cooling down after training/match	1–28	1	20
4	Maximum power of lower limbs	22, 23, 24, 26, 27	1	05
			2	15
			3	05

Prog. No.	Reasonable areas of application Indications	Possible electrode position	Phase	Running time (minutes)
5	Resistance of lower limbs	22, 23, 24, 26, 27	1	05
			2	20
			3	05
6	Explosive power of lower limbs	22, 23, 24, 26, 27	1	05
			2	12
			3	05
7	Maximum power of torso and upper limbs	1–20	1	05
			2	15
			3	05
8	Resistance of torso and upper limbs	1–20	1	05
			2	12
			3	05
9	Explosive power of torso and upper limbs	1–20	1	05
			2	12
			3	05
10	Lipolysis of lower limbs	22, 23, 24, 26, 27	1	40
11	Toning of lower limbs	22, 23, 24, 26, 27	1	20
			2	10
12	Strengthening of lower limbs	22, 23, 24, 26, 27	1	20
			2	10
13	Shaping of lower limbs	22, 23, 24, 26, 27	1	20
			2	20
14	Increasing size of lower limbs	22, 23, 24, 26, 27	1	15
15	Lipolysis of stomach muscles	18,19, 20	1	40
16	Toning of stomach muscles	18,19, 20	1	20
			2	10
17	Strengthening of stomach muscles	18,19, 20	1	20
			2	10
18	Shaping of stomach muscles	18,19, 20	1	20
			2	20
19	Toning of upper limbs	12–17	1	20
			2	10
20	Strengthening of upper limbs	12–17	1	20
			2	10

Prog. No.	Reasonable areas of application Indications	Possible electrode position	Phase	Running time (minutes)
21	Shaping of upper limbs	12–17	1	20
			2	20
22	Increasing size of upper limbs	12–17	1	15
23	Toning of hips and thighs	20, 23, 24	1	20
			2	10
24	Strengthening of hips and thighs	20, 23, 24	1	20
			2	10
25	Toning of gluteal muscles	22	1	20
			2	10
26	Strengthening of gluteal muscles	22	1	20
			2	10
27	Shaping of gluteal muscles	22	1	20
			2	20

i The EMS 28–30 programme can be set individually, see 7.3.3 (p. 24).

6.5 MASSAGE program table

Prog. No.	Reasonable areas of application Indications	Phase	Running time (minutes)
1	Muscle strain relief	1	20
2	Relaxing massage	1	25
3	Invigorating massage	1	20
4	Tapping massage	1	15
5	Tapping and jet massage	1	15
6	Vibrating massage	1	20
7	Warm up massage 1	1	20
8	Warm up massage 2	1	10
9	Pressure massage	1	20
10	Kneading and pressure massage	1	20

Electrodes must be placed so that they surround the muscle segments in question. For optimal effect, electrode distance must not be greater than approx. 15 cm.

The electrodes should not be applied to the anterior wall of the thorax, i.e. never massage the left or right large pectoral muscle.

7. Application

7.1 Advice on application

- If the machine is not used within 2 minutes, it switches off automatically (automatic switch-off function). When the unit is switched on again, the LCD screen displays the menu selection and the most recently used menu flashes.
- If an admissible key is pressed, there is one short beep. If an inadmissible key is pressed, there are two short beeps.
- You can pause the stimulation at any time by briefly pressing the ON/OFF button **i**. To continue the stimulation, briefly press the ON/OFF button **i** again and set the desired impulse intensity again.

7.2 Procedure for programs TENS 1–7, EMS 1–27 and MASSAGE 1–10 (quick start)

- Select a suitable program from the program tables (p. 22–23).
- Place the electrodes on the desired area for treatment (for positioning suggestions see electrode positions, p. 2) and connect them to the device.

Selecting a program

- Press the ON/OFF button **i** to switch on the device.
- Using the **M** button, navigate through the menus **TENS** / **EMS** / **MASSAGE** (Fig. 1, Example TENS display) and confirm your selection with the **E** button.
- Using the **UP/DOWN** buttons, select the desired program and confirm your selection with the **E** button (Fig. 2, Example TENS program 03).



Fig. 1

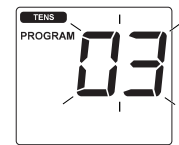

Fig. 2

i General information

If you wish to return to the previous selection menu, press the **M** button. By holding down the **E** button, you can skip individual setting steps and start directly with the stimulation treatment.

Setting the impulse intensity

- **i** At the start of stimulation treatment, the impulse intensity of **Ch1** and **Ch2** is set to 00 as default. No impulses are sent to the electrodes yet.

- Using the INTENSITY SETTING buttons, select the desired impulse intensity. The impulse intensity display is adjusted accordingly (Fig. 3). The impulse intensity of **Ch1** and **Ch2** can be set individually.

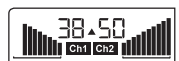

Fig. 3

- If the program is in a pause phase, the intensity cannot be increased.
- If you wish to end the stimulation treatment early, press the ON/OFF button **i**.

7.3 Setting individual parameters

7.3.1 Setting the treatment time

Using the **UP/DOWN** buttons, select the desired treatment time. You can set a treatment time from 5 minutes to 100 minutes (Fig. 4, Example treatment time of 20 min.). Confirm your selection with the **E** button. The stimulation treatment begins and the operation status display starts to flash alternately (Fig. 5).

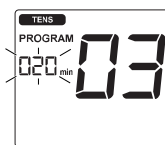

Fig. 4



Fig. 5

7.3.2 Setting individual TENS programs

Procedure for TENS 08 program

TENS 08 is a preset program that you can also personalise. In this program you can set the impulse frequency to between 1 and 150 Hz and the impulse width to between 50 and 250 μ s.

- Place the electrodes on the desired area for treatment (for positioning suggestions see electrode positions, p. 2) and connect them to the device. Select the TENS 08 program, as described in section 7.2 “Selecting a program” (p. 23).
- Using the **UP/DOWN** buttons, select the desired impulse frequency and confirm with the **E** button (Fig. 1, Example impulse frequency of 100 Hz).
- Using the **UP/DOWN** buttons, select the desired impulse width and confirm with the **E** button (Fig. 2, Example impulse width of 200 μ s).
- Select the desired treatment time, as described in 7.3.1 “Setting the treatment time” (p. 24).
- Select the desired impulse intensity, as described in 7.2 “Setting the impulse intensity” (p. 23).

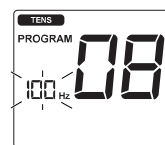

Fig. 1

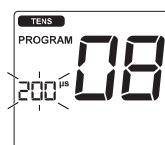

Fig. 2

Procedure for the TENS 09 program

TENS 09 is a preset **burst** program that you can also personalise. In this program, you can set the impulse width to between 50 and 250 μ s.

- Place the electrodes on the desired area for treatment (for positioning suggestions see electrode positions, p. 2) and connect them to the device. Select the TENS 09 program, as described in 7.2 “Selecting a program” (p. 23).

- Using the **UP/DOWN** buttons, select the desired impulse width and confirm with the **E** button (Fig. 1, Example impulse width of 200 μ s).
- Select the desired treatment time, as described in 7.3.1 “Setting the treatment time” (p. 24).
- Select the desired impulse intensity, as described in 7.2 “Setting the impulse intensity” (p. 23).

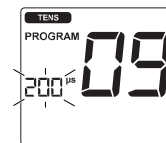

Fig. 1

Procedure for the TENS 10 program

TENS 10 is a preset program that you can also personalise. In this program, you can set the impulse frequency to between 1 and 150 Hz. The impulse width changes automatically during the stimulation treatment.

- Place the electrodes on the desired area for treatment (for positioning suggestions see electrode positions, p. 2) and connect them to the device. Select the TENS 10 program, as described in 7.2 “Selecting a program” (p. 23).
- Using the **UP/DOWN** buttons, select the desired impulse frequency and confirm with the **E** button (Fig. 1, Example impulse frequency of 100 Hz).
- Select the desired treatment time, as described in 7.3.1 “Setting the treatment time” (p. 24).
- Select the desired impulse intensity, as described in 7.2 “Setting the impulse intensity” (p. 23).

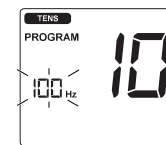

Fig. 1

7.3.3 Setting individual EMS programs

Procedure for the EMS 28 program

EMS 28 is a preset program that you can also personalise. In this program, you can set the impulse frequency to between 1 and 100 Hz and the impulse width to between 50 and 320 μ s.

- Place the electrodes on the desired area for treatment (for positioning suggestions see electrode positions, p. 2) and connect them to the device. Select the EMS 28 program, as described in 7.2 “Selecting a program” (p. 23).
- Using the **UP/DOWN** buttons, select the desired impulse frequency and confirm with the **E** button (Fig. 1, Example impulse frequency of 30 Hz).

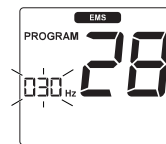

Fig. 1

- Using the **UP/DOWN** buttons, select the desired impulse width and confirm with the **E** button (Fig. 2, Example impulse width of 250 μ s).
- Select the desired treatment time, as described in 7.3.1 “Setting the treatment time” (p. 24).
- Select the desired impulse intensity, as described in 7.2 “Setting the impulse intensity” (p. 23).



Fig. 2

Procedure for the EMS 29 program

EMS 29 is a preset program that you can also personalise. In this program, you can set the impulse frequency to between 1 and 100 Hz. The impulse width changes automatically during the stimulation treatment.

- Place the electrodes on the desired area for treatment (for positioning suggestions see electrode positions, p. 2) and connect them to the device. Select the EMS 29 program, as described in 7.2 “Selecting a program” (p. 23).
- Using the **UP/DOWN** buttons, select the desired impulse frequency and confirm with the **E** button (Fig. 1, Example impulse frequency of 30 Hz).
- Select the desired treatment time, as described in 7.3.1 “Setting the treatment time” (p. 24).
- Select the desired impulse intensity, as described in 7.2 “Setting the impulse intensity” (p. 23).

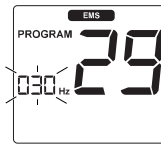

Fig. 1

Procedure for the EMS 30 program

EMS 30 is a preset program that you can also personalise. In this program, you can set the impulse frequency to between 1 and 100 Hz. You can also set the working time and pause time for this program to between 1 and 30 seconds each.

- Place the electrodes on the desired area for treatment (for positioning suggestions see electrode positions, p. 2) and connect them to the device. Select the EMS 30 program, as described in 7.2 “Selecting a program” (p. 23).
- Using the **UP/DOWN** buttons, select the desired length of working time and confirm with the **E** button (Fig. 1, Example working time of 2 seconds).

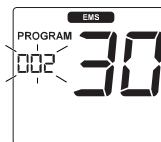

Fig. 1

- Using the **UP/DOWN** buttons, select the desired length of pause time and confirm with the **E** button (Fig. 2, Example pause time of 10 seconds).
- Using the **UP/DOWN** buttons, select the desired impulse frequency and confirm with the **E** button (Fig. 3, Example impulse frequency of 30 Hz).
- Select the desired treatment time, as described in 7.3.1 “Setting the treatment time” (p. 24).
- Select the desired impulse intensity, as described in 7.2 “Setting the impulse intensity” (p. 23).

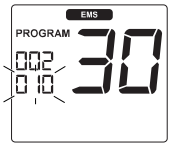

Fig. 2

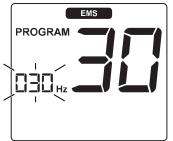

Fig. 3

7.4 Changes to the settings

Changing intensity (during application)

- **Ch1 +/-** und **Ch2 +/-**: Changing the intensity for each channel.

Interrupting stimulation

Press the ON/OFF button **I**.

Changing application (completely or single parameters)

- ON/OFF button **I**: to interrupt stimulation
- Setting the program, see 7.2; setting individual parameters, see 7.3.

7.5 Doctor’s Function

Doctor’s Function is a specific setting to allow you to call up your specific personal programme even more easily.

Your individual program settings are instantly recalled and activated when the device is switched on.

Settings for this individual programme may, for example, be on the advice of your doctor.

Setting the Doctor’s Function

- Select your programme and appropriate settings as described under 7.2 or 7.3.
- At the start of the stimulation treatment, the impulse intensity of **Ch1** and **Ch2** is set to **00** as default. No impulses are sent to the electrodes yet. Before setting the desired impulse intensity using the intensity setting buttons, press and hold the **Ch2-** button for 5 seconds. Storage in the Doctor’s Function is confirmed with a long acoustic signal.

Canceling Doctor's Function

To clear the device again and to reallow access to other programs, press and hold the **Ch2** - button again for approx. 5 seconds. To do this, the impulse intensity of **Ch1** and **Ch2** must be set to 00. Deletion of the Doctor's Function is confirmed with a long acoustic signal.

8. Cleaning and storage

Adhesive electrodes

- To ensure that the adhesive electrodes remain adhesive for as long as possible, clean them carefully with a damp, lint-free cloth or clean the underside of the electrodes under lukewarm running water and pat dry with a lint-free cloth.

 Before cleaning with water, remove the connection cables from the electrodes.

- After use, stick the electrodes onto the backing film.

Cleaning the unit

- Remove the batteries from the device every time you clean.
- Clean the unit after use with a soft, slightly moistened cloth. In case of more extreme soiling you can also moisten the cloth with mild soapy water.
- Do not use any chemical cleaners or abrasive agents for cleaning.

 Ensure that no water enters the device.

Storage

- Remove the batteries from the unit if you are not going to use it for a longer period. Leaking batteries can damage the unit.
- Do not make any sharp kinks in the connecting leads or electrodes.
- Detach the connecting cable from the electrodes.
- After use, stick the electrodes onto the backing film.
- Store the machine in a cool, well-ventilated place.
- Never place any heavy objects on the machine.

9. Disposal

Used, fully discharged batteries must be disposed of in a specially labeled collection container, at toxic waste collection points or through an electrical retailer.

You are under legal obligation to dispose of batteries correctly.

Note: You will find these markings on batteries containing harmful substances: Pb = battery containing lead, Cd = battery containing cadmium, Hg = battery containing mercury.



Please dispose of the device in accordance with the directive 2002/96/EC – WEEE (Waste Electrical and Electronic Equipment). If you have any queries, please refer to the local authorities responsible for waste disposal.



10. Problems and solutions

The machine does not switch on when the ON/OFF button  is pressed.



What should I do?

- (1) Make sure that the batteries have been inserted correctly and have contact.
- (2) Change the batteries if necessary.
- (3) Contact customer service.

The electrodes are detaching themselves from the body. What should I do?

- (1) Clean the adhesive surface of the electrodes with a damp, lint-free cloth. Then let them dry in the air and attach them again. Should the electrodes still not adhere firmly, they must be replaced.
- (2) Before each application, clean the skin, avoiding using any skin cream or oils before treatment. Shaving can increase adhesion of the electrodes.

There is no noticeable stimulation. What should I do?

- (1) Interrupt the programme by pressing the ON/OFF button . Make sure that the connecting leads are properly connected to the electrodes. Make sure that there is a firm contact between the electrodes and the treatment area.
- (2) Make sure that the plug of the connecting lead is firmly connected to the machine.
- (3) Press the ON/OFF key  to start the programme again.
- (4) Check that the electrodes are positioned properly and make sure that the adhesive electrodes are not overlapping.
- (5) Increase pulse intensity in stages.
- (6) The batteries are almost empty. Replace these.

What to do if the battery symbol is displayed.

Replace all batteries.

You are aware that the electrodes feel uncomfortable. What should I do?



- (1) The electrodes are badly positioned. Check positioning and if necessary reposition the electrodes.
- (2) The electrodes are worn. Due to the fact that current distribution can no longer be guaranteed evenly over the entire surface, these may lead to skin irritation. You must therefore replace these.

The skin in the treatment area becomes red. What should I do?

Stop treatment immediately and wait until the skin has returned to normal. If any redness beneath the electrode soon disappears, this is not dangerous and is due to the increased circulation which has been stimulated locally.

If, however, the skin irritation remains and there is possibly itching or inflammation, please consult your doctor before further use. It may possibly be caused by an allergy to the adhesive surface.

11. Technical details

Name and model:	SEM 43
Initial curve shape:	biphase square-wave pulse
Pulse duration:	50–450 μ s
Pulse frequency:	1–150 Hz
Output voltage:	max. 100 Vpp (at 500 Ohm)
Output current:	max. 200 mApp (at 500 Ohm)
Power supply:	3x AAA batteries
Treatment time:	adjustable from 5 to 100 minutes
Intensity:	adjustable from 0 to 50
Operating conditions:	10 °C–40 °C (50 °F–104 °F) with a relative humidity of 30–85 %
Storage conditions:	-10 °C–50 °C (14 °F–122 °F) with a relative humidity of 10–95 %
Dimensions:	135 x 66 x 29 mm (incl. belt clip)
Weight:	107 g, (incl. belt clip, without batteries) 133 g, (incl. belt clip and batteries)
Explanation of symbols:	Application part type BF  Caution! Read the instructions for Use. 

Note: If the machine is not used according to these specifications, perfect functioning is not guaranteed.

We reserve the right to make any technical alterations that are necessary in order to improve and develop the product further.

This unit is in line with European Standards EN60601-1, EN60601-1-2 and EN60601-2-10 and is subject to particular precautions with regard to electromagnetic compatibility (EMC). Please note that portable and mobile HF communication systems may interfere with this unit. For more details, please contact customer service at the address indicated.

The machine meets the requirements of the European Medical Products Directive 93/42/EC and the German Medical Products Act.