

# ASSEMBLY GUIDE

BODY EASE - 7 SPEED

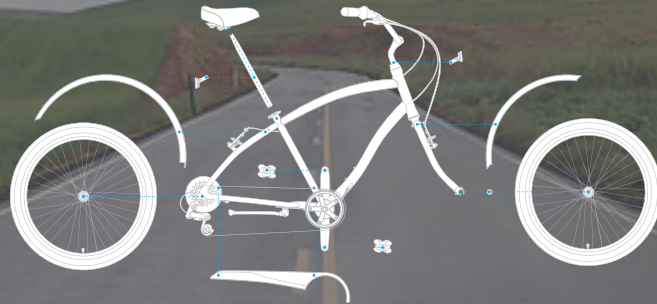

SIXTHREEZERO





# OUR COMMITMENT

We want you to love your bike as much as we do.  
If you run into any issues, no matter how small,  
let us know and we'll take care of it.

SIXTHREEZERO

THETEAM@SIXTHREEZERO.COM

310.982.2877

# MEET JACOB, OUR MECHANIC

Need assembly, repair, or installation assistance? He's your guy!  
Want live help? Call or email to schedule an appointment.



[MECHANICS@SIXTHREEZERO.COM](mailto:MECHANICS@SIXTHREEZERO.COM)

310.982.2877

A NOTE FROM  
OUR MECHANIC

Welcome to the sixthreezero experience. Now for the fun part... the assembly.

I know, I know, we've all had to assemble something we've bought before - a tv stand, coffee table, possibly a grill or even a bike a time or two before. It's never fun, it never goes well, you always lose a nut or a screw and by the time you're done, you'd rather destroy whatever it is you've bought than actually use it. Well, I'm here to make sure that doesn't happen.

Assembly of a bike can be a fun, engaging, learning experience. Call up a friend, ask your spouse or child, don't

rush, and enjoy the process. Part of the fun in building your bike is telling people "I built it all by myself." I build bikes almost everyday and I always learn something new. I enjoy the process of building something from the ground up, and I hope you will too.

The instructions were written and designed by me, so if you have any suggestions please let me know!

Good luck,

A handwritten signature in black ink that reads "JACOB". The letters are stylized and connected, with a prominent flourish at the end of the word.

MECHANIC / SIXTHREEZERO

# **TOOLS YOU'LL NEED**

Creating something wonderful with your own hands is basically the best feeling ever. We want you to have fun building your new bike, so there's only a few things you need to get started.



**SCISSORS**  
(use to cut zip ties)



**8, 10, 13, AND 15MM  
CRESCENT WRENCHES**  
or use the multi-tool provided



**4, 5, AND 6MM  
ALLEN KEY**



**PHILLIPS HEAD  
SCREWDRIVER**



**SCHRADER VALVE  
BICYCLE PUMP**



**BICYCLE OR  
AUTO GREASE**  
recommended



# WHAT'S IN EACH BOX?

Lay out all the parts in front of you.  
Make sure you have all the parts before getting started.

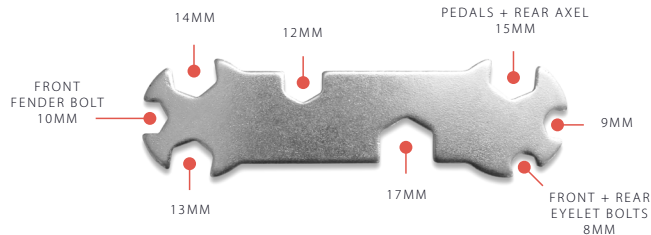





**HANDLE BAR / FRAME / REAR  
WHEEL AND REAR RACK SET-UP**

Seat post is zip-tied to frame



**QUICK RELEASE  
FRONT WHEEL**



**FRONT REFLECTOR**  
pre-installed

---

**BOX 1**



**EXPERIENCE  
BOOKLET**



**ASSEMBLY  
GUIDE**



**MULTI-TOOL**



**4, 5, AND 6MM  
ALLEN KEYS**



**PEDALS**



**SEAT ATTACHED TO  
SEAT TUBE**



**QUICK RELEASE  
SKEWER**



**HARDWARE**

---

**BOX 3**

---

**BOX 4**

# **BIKE PARTS REFERENCE**

All the names of all the parts for your bike, all in one place.  
Keep this handy during assembly, and everything will go just fine.



# FRONT WHEEL + REAR RACK

Parts required:



QUICK RELEASE  
FRONT WHEEL



FRAME, REAR RACK  
+ REAR WHEEL



QUICK  
RELEASE SKEWER

Tools you'll need:



4MM + 5MM  
ALLEN KEY



(4) 4MM ALLEN  
KEY SCREWS  
**(pre-installed)**

# 01

Spin the front fork so that the brakes are pointing forward.

## CORRECT

The front brake is facing away from the bike body.



## INCORRECT

The brakes are behind the fork.



# 02

Pinch front brake arms, pulling the metal tubing up and out until it is disengaged and the brake arms are open.

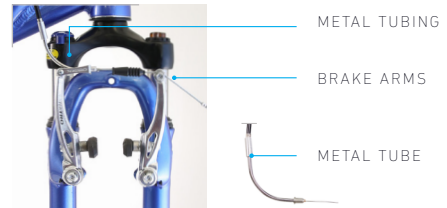

# 03

Locate the arrow on the wall of the tire and position the tire like the image below. With the arrow pointing forward, insert the wheel into the fork dropouts. The axle nuts will fall inside the fork entry.



**CAUTION**  
DO NOT untighten axle nuts on the front wheel.

FORK DROPOUTS

AXLE NUTS

# 04



5MM ALLEN KEY

Use a 5mm allen key to loosen the front brake pads and rotate them horizontally. Retighten them.

Reattach the brake arms by connecting the metal tube as shown.





# 05



All of the components for the quick release skewer are attached out of the box.



Unscrew **QR5** and remove **QR4**. Do not remove **QR2** and **QR3** from the quick release handle **QR1**.

## NOTE

Quick release skewer must be installed correctly to avoid bicycle damage and/or injuries.

# 06

Insert the quick release skewer through the hub opening on either side of the wheel, as shown below.

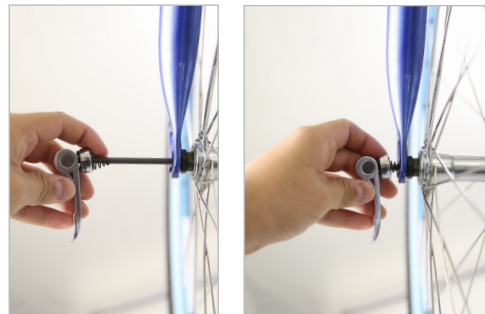

Slide quick release skewer completely through the hub.

**07**



Place **QR4** on the open side of the quick skewer, with the smaller end pointing inward.



**08**



Making sure the wheel is straight, attach **QR5** to **QR1** by compressing the spring completely. Hold the quick release lever in place and tighten **QR5** lightly.

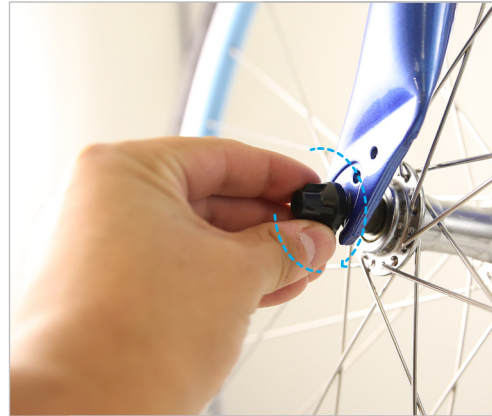

## 09

Lift the lever up towards the fork. If the lever does not lock in place smoothly, loosen **QR5** slightly and try again. It will take a small amount of strength, but that is normal.

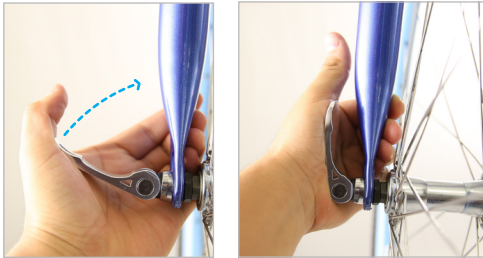

### NOTE

The lever should be tight enough to feel resistance at a 90° angle. Make sure the front wheel is securely tightened and properly aligned so there are no issues when you assemble the brakes.

## 10

Once the front wheel is secured, lower the kickstand.



# 11



4MM  
ALLEN KEY



(2) 4MM ALLEN  
KEY SCREWS  
(pre-installed)



REAR  
RACK

Align the front rear rack arms to the eyelets on the frame below the seat. Use a 4mm allen key to tighten the screws and attach the rear rack to the frame.



# 12



4MM  
ALLEN KEY



(2) 4MM ALLEN  
KEY SCREWS  
(pre-installed)



REAR  
RACK

Install the bottom rear rack arms to the frame using the 4mm allen screws. Tighten with a 5mm allen key. Repeat on both sides.



# HANDLEBAR, SEAT + PEDALS



PEDALS



5MM + 6MM  
ALLEN KEY



15MM  
MULTI-TOOL



BICYCLE  
PUMP



HANDLEBAR



SEAT ATTACHED  
TO SEAT TUBE



PHILLIPS  
SCREWDRIVER



BICYCLE OR  
AUTO GREASE

WATCH ASSEMBLY VIDEOS ON OUR YOUTUBE CHANNEL, [HTTPS://SIXTHREEZERO.COM/PAGES/ASSEMBLY](https://sixthreezero.com/pages/assembly)

# 13



LOCK NUT CAP



HANDLEBAR

Insert the handlebar stem through the lock nut cap and into the headtube. Line up the stem, frame, and front wheel, then tighten the handlebar stem bolt.

### NOTE

Straightening the stem, frame, and front wheel will ensure that your handlebars and wheel are properly aligned.



# 14



6MM  
ALLEN KEY

Line up the stem, frame, and front wheel, then tighten the handlebar stem bolt.

Loosen handlebar adjustment bolt using the 6mm Allen key.



# 15



6MM  
ALLEN KEY

Loosen handlebar adjustment bolts using the 6mm Allen key.



# 16



6MM  
ALLEN KEY



HANDLEBAR

Place handlebar between the stem and faceplate, then insert and tighten the allen key bolts with a 6mm Allen key. Tighten to an appropriate tension until the handlebar has no free play (Wiggle or Move).



# 17



PHILLIPS  
SCREWDRIVER



FRONT  
REFLECTOR

Straighten the reflector so that it points forward.



Adjust the position of the front reflector by loosening the screw on the bracket.

# 18



BICYCLE OR  
AUTO GREASE

Our suspension seat post absorbs bumps while travel. There is no adjustment required. Due to the suspension on the seatpost, the seat will be raised an inch above the seatpost clamp and that is normal.

Apply great to seat lever, then open seat post clamp. Holding the seat post firmly, insert into seat post tube until the top is level with your waist.

Close the seat post clamp lever.





# 19



BICYCLE OR  
AUTO GREASE



15MM  
MULTI-TOOL



PEDALS

Apply grease to threading on both pedals.

Select the pedal stamped R and locate the right side of the bike (with the chain and chain guard). Align threading with the right crank arm, turning the pedal clockwise to tighten it.

Locate the pedal stamped L and align with the left crank arm. The left side pedal is reverse-threaded, tightening in a counterclockwise direction.

Hand tighten accordingly, then follow up by tightening both pedals with the 15mm multi-tool or crescent wrench.



# 21



BICYCLE PUMP

Pump air into the tires to **PSI 40-65MAX**, as recommended on the sidewall of the tire.



# 22

Sit on the bike and check the angle formed by your knee.

If your knee forms the incorrect angle, use the seat post clamp lever to raise the seat until you have a subtle bend or achieve a comfortable height.

**CORRECT**



**INCORRECT**



# BRAKE ASSEMBLY

## DIAGRAM

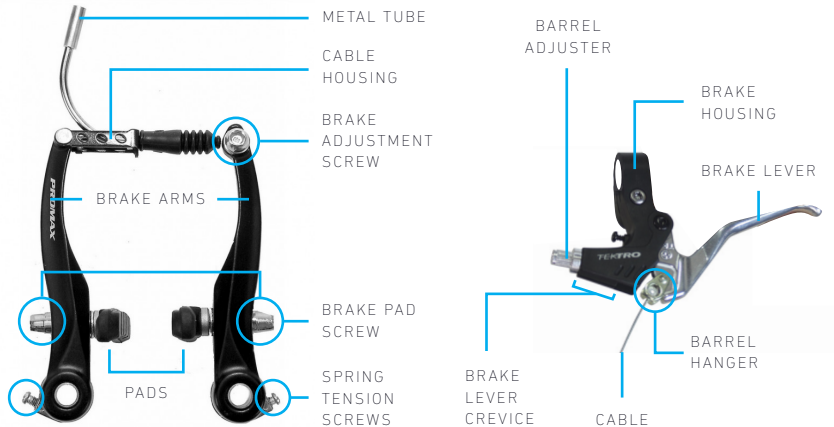

## TOOLS REQUIRED

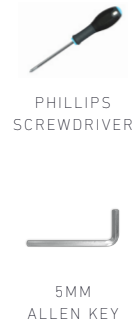

WATCH ASSEMBLY VIDEOS ON OUR YOUTUBE CHANNEL, [HTTPS://SIXTHREEZERO.COM/PAGES/ASSEMBLY](https://sixthreezero.com/pages/assembly)

## NOTE

Only follow steps 1-9 if your brake cable is not attached to the bicycle.

If your brake cable is attached, skip to step 10.



ATTACHED  
BRAKE CABLE

# 01

There are two ends to the brake cable.

One end has a barrel attached, while the other end has an open piece of cable.

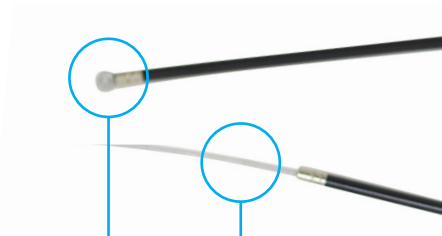

BARREL

CABLE

**02**

Attach the brake cable to the brake lever by squeezing the lever and inserting the barrel into the barrel hanger.



BARREL  
ADJUSTER

BARREL  
HANGER

**03**

Pull on the cable and slide it through the narrow crevice that runs along the brake lever.



BRAKE  
LEVER CREVICE

**04**

Slide the cable housing up toward the brake lever until it fits snug inside the barrel adjuster.



BARREL ADJUSTER

**05**

Turn the lock ring on the barrel adjuster clockwise, tightening the barrel to prevent any loose movement.



LOCK RING

# 06

Insert the open end of the brake cable into the larger end of the metal tube.

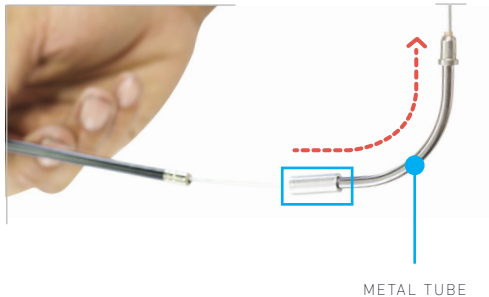

# 07

Slide the metal tube up the brake cable until the housing fits snugly into the cable housing.

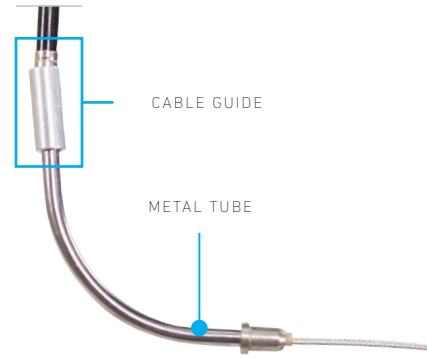

# 08

Slide the exposed end of the metal into the metal tube hanger, located on the left brake arm. Make sure the metal tube is hooked securely inside the hanger.



LEFT  
BRAKE ARM

METAL TUBE  
HANGER

END OF  
METAL TUBE

# 09



5MM ALLEN KEY

Using a 5mm Allen key, loosen the brake cable adjustment screw. Slide remaining brake cable between the right brake arm and the adjustment screw.

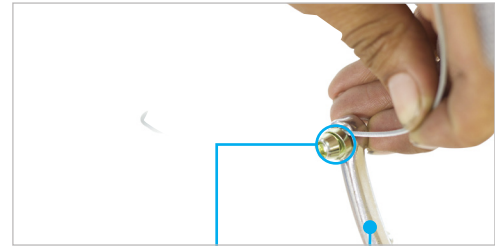

BRAKE ADJUSTMENT SCREW

RIGHT BRAKE ARM

# 10

Pull the cable outward, reducing the distance between the brake pads and the rim by about 1/4 inch on both sides. Retighten the adjustment screw.



CABLE

# 11



5MM  
ALLEN KEY

Make sure the pads are evenly lined up with the rim. If the pads rub against the tire, they are too high; if they don't make full contact with the rim when braking, they are too low.

Adjust the positions by holding the brake pad with one hand and loosening the nut on the back with a 5mm Allen key.



ADJUST WITH  
5MM ALLEN KEY



# 12

---

If one pad seems to run against the rim while the other still has plenty of space, you will need to center the brakes. To do this, adjust the spring tensioner screws located at the base of each brake arm.

Tightening the screw on the right brake arm pushes the right brake pad away from the rim, and the left brake pad towards the rim.

Loosening the right screw allows the right brake pad to move closer to the rim, and the left brake pad away from the rim.

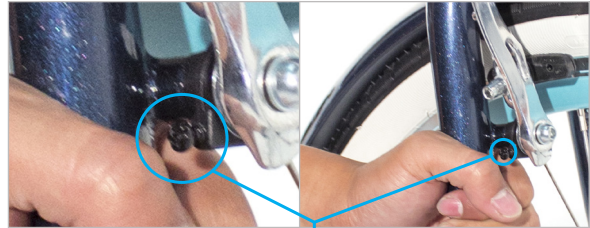

SPRING  
TENSIONER SCREW

# 7 SPEED DERAILLEUR TUNING

## DIAGRAM

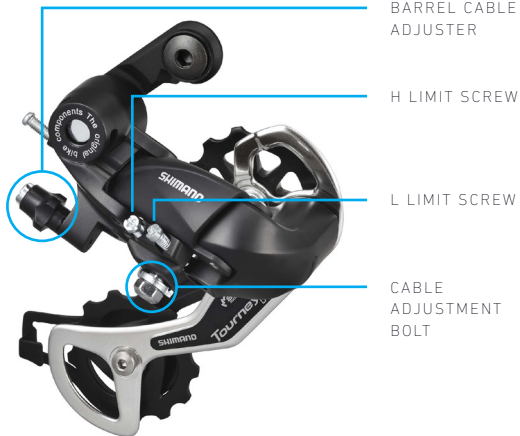

BARREL CABLE  
ADJUSTER

H LIMIT SCREW

L LIMIT SCREW

CABLE  
ADJUSTMENT  
BOLT

## TOOLS REQUIRED



PHILLIPS  
SCREWDRIVER



9MM  
MULTI-TOOL

# 01

To adjust the rear derailleur, first twist the shifter until the number **7** is highlighted on the shift knob.



# 02

Rotate pedals until the chain falls into the smallest cog.



## 03

Turn the barrel adjuster located on the rear derailleur clockwise until it stops.



BARREL  
ADJUSTER

## 04

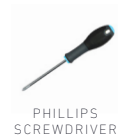

If the chain still hasn't reached the smallest cog, then you will need to adjust the "High Gear" limiting screw located on the derailleur (indicated by the letter **H**).

With a Phillips screwdriver, gradually turn the screw counterclockwise 1/4 turn at a time while rotating the pedal until the chain falls onto the smallest cog.



### NOTE

The "High Gear" limiting screws are very sensitive. We recommend using only 1/4 turn at a time, in case you have to revert back to its original position.

## 05



Now adjust the cable tension, which controls how your bike will shift. Using a 9mm crescent wrench or the multi-tool, loosen the cable adjustment screw and pull on the cable. While keeping tension on the cable, tighten the cable adjustment screw.



## 06

Rotate the pedals and try to shift between gears. If it doesn't shift from 7th to 6th gear in one click, then the cable needs to be tightened. To tighten the cable, twist the barrel adjuster counterclockwise 1/4 turn at a time until it is able to shift from 7th to 6th gear in one click.

Shift through the gears from 7th to 1st, then back from 1st to 7th. If the gears feel sluggish when shifting from 7th to 1st, tighten the cable by turning the barrel adjuster counterclockwise. If shifting feels fine from 7th to 1st, but sluggish from 1st to 7th, loosen the cable by turning the barrel adjuster clockwise.

Continue to adjust the derailleur cable until you are able to shift between each gear with a single click.



### NOTE

Each gear should shift with a corresponding "click" sound.

## FORK SUSPENSION

# 01

---

Your bike is equipped with front fork spring suspension.

The position of blue lever indicates whether the front fork is locked or unlocked.

The front fork is locked if the blue lever is highlighting the color red. If the blue lever is highlighting the color green, the front fork is unlocked allowing for damped and cushioned ride.



## 02

---

There is no need to adjust the tension of the spring right out of the box. If you do decide to add or relieve tension, note the amount of twist and/or rotations in any given direction it took to get to your preferred riding stiffness or softness.



## **03**

---

Your bike should be ready to ride at this point. Time to enjoy the ride! If you have/had any trouble at all, please feel free to contact our team at:

(310) 982-2877

[theteam@sixthreezero.com](mailto:theteam@sixthreezero.com)



# SURVEY

---

Tell us about your assembly experience. If you have/had any trouble at all or didn't, and would like to leave feedback and help us improve our assembly instructions you can.

Type this URL into your browser:

[goo.gl/6enZji](https://goo.gl/6enZji)

# CONGRATULATIONS

You did it! Time to take your brand new bike for a spin.

Still have questions? We're happy to help.

Want to share your journey with us? We're happy about that, too.



SIXTHREEZERO

THETEAM@SIXTHREEZERO.COM

310.982.2877





SIX**THREE**ZERO  
LOS ANGELES, CA

INFO@SIXTHREEZERO.COM  
310.982.2877