

**PLEASE SPEND 2 MINUTES  
READING THESE  
INSTRUCTIONS BEFORE  
USING YOUR NEW RATCHET  
NUTSERT TOOL.**

**TRUST US, IT WILL SAVE YOU  
TIME AND INCONVENIENCE IN  
THE LONG RUN.**

# RATCHET NUTSERT & RIVSTUD TOOL GUIDE – NT-M510IMP

## TOOL SPECIFICATIONS

| NT-M510IMP Specifications |   |
|---------------------------|---|
| Tool Weight               | 1.2Kg   |
| Total Weight              | 2.5Kg   |
| Body Material             | Steel   |
| Lever Material            | Steel   |
| Fastener Capacity         | Metric: M5, M6, M8 and M10 – all styles & materials<br>Imperial (UNC): 3/16", 1/4", 5/16" and 3/8" – all styles & materials |

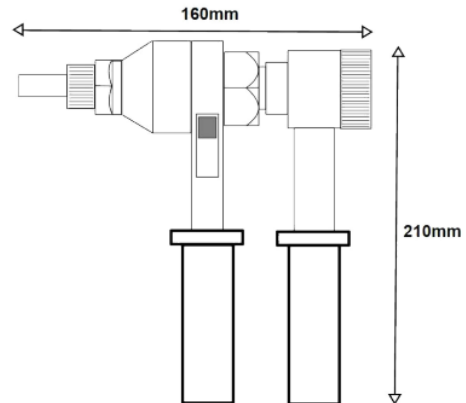

## CHANGING THE TOOL MANDRELS

- 1) Unscrew the anvil & locknut.
- 2) Pull the mandrel to remove it from the tool body.
- 3) Select the correct mandrel size from the kit.
- 4) Slide the mandrel into the tool body from the back.
- 5) Place the correct anvil on the front of the mandrel along with the locknut and tighten.

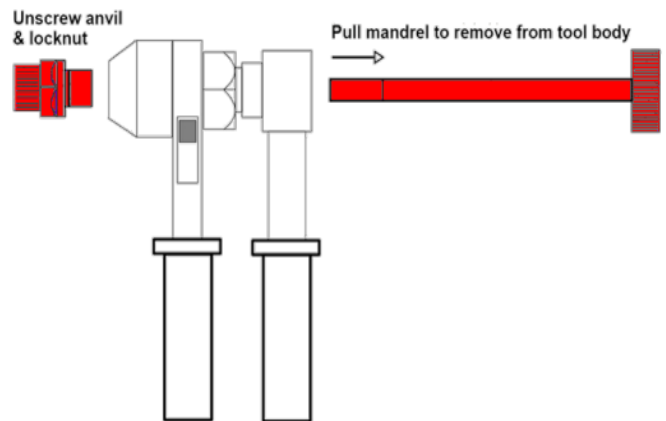

## SETTING UP THE TOOL

- 1) With the tool facing as pictured, set the ratchet switch in the UP position.
- 2) Holding the forward handle still, rotate the rear handle clockwise until it clicks.
- 3) Rotate the rear handle anti-clockwise 1 – 2 turns to create the 1.0mm gap. The tool is now ready for use as the ratchet is engaged.

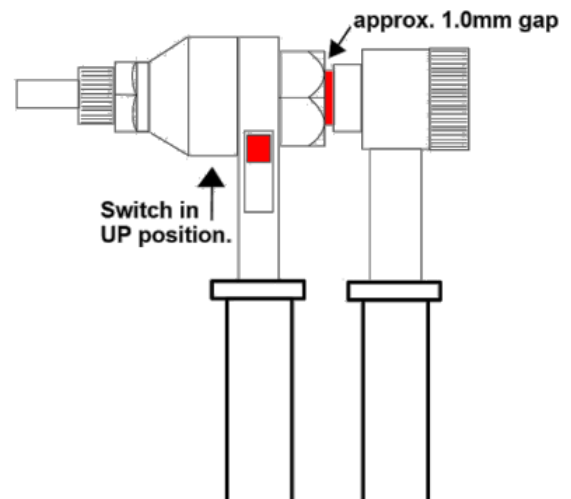

- 4) Screw a rivnut onto the mandrel until approximately 1 thread of the mandrel protrudes through the rivnut.
- 5) Screw the anvil out until it engages the head of the rivnut.
- 6) Tighten the locknut so that the anvil is fixed in position.

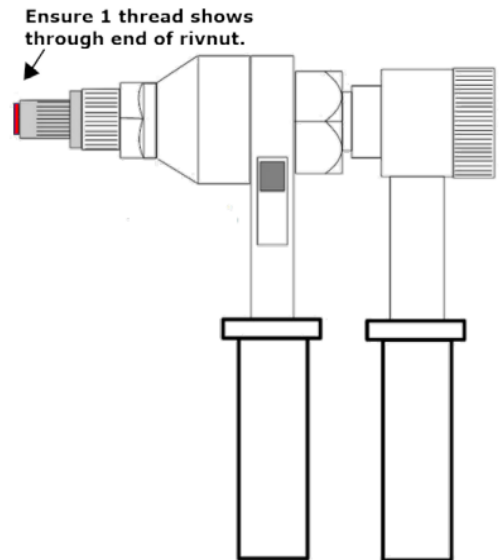

### SETTING A NUTSERT

- 1) Wind a rivnut onto the mandrel (as per image in previous steps) until it comes into contact with the nose tip. If the tool is setup correctly, you should see 1 mandrel thread protruding from the end of the rivnut.
- 2) With the tool facing as pictured, put the ratchet switch in the UP position. Insert the tool with the rivnut on the mandrel into the pre-prepared hole in your work piece.
- 3) Hold the forward handle still and rotate the rear handle right to left. The rivnut will pull up and form a flange on the rear side of your work piece.

***Do not pull the rivnut up too tightly as you may strip the thread in the rivnut or damage the tool mandrel.***

4. When the rivnut is correctly installed, move the ratchet switch to the DOWN position.
5. Again, holding the forward handle still, rotate the rear handle clockwise one turn to release the rivnut from the mandrel.

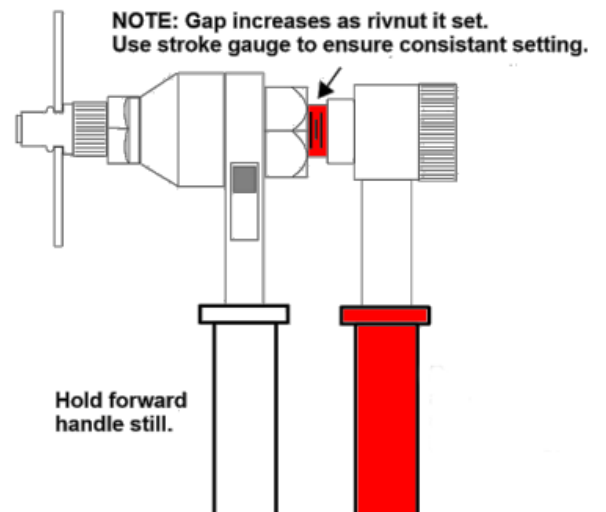
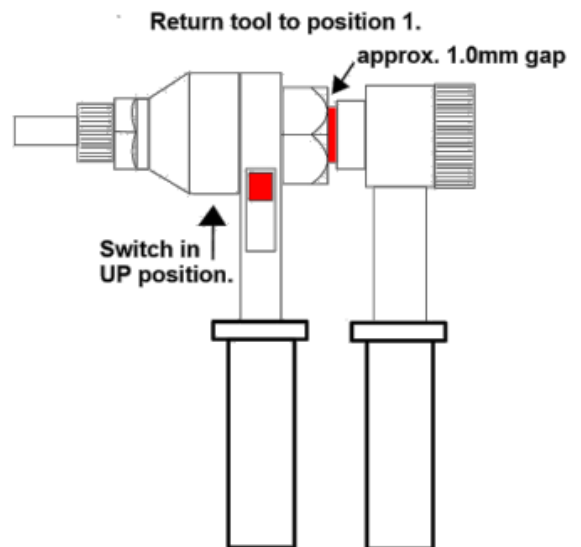

6. Rotate the splined knob on the back of the mandrel anticlockwise to remove the mandrel from the set rivnut.

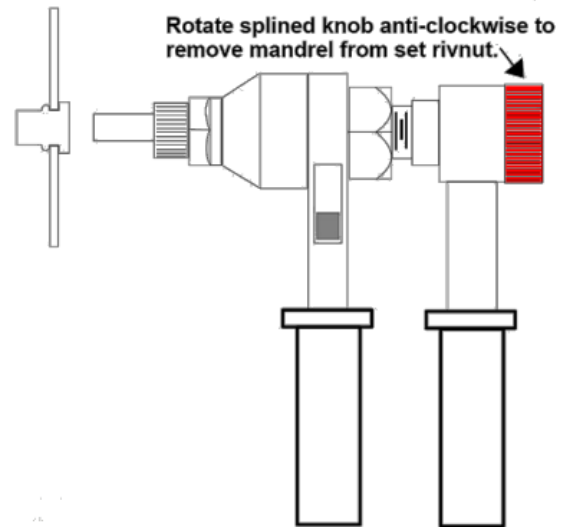

7. To set another rivnut, the tool must be returned to position 1. Do this by placing the ratchet switch in the UP position and then rotating the rear handle clockwise until the ratchet mechanism engages (clicks) and the mandrel is fully forward again. You are now ready to repeat the setting process from step 1 above.

