

FBLS FIRE BLOCK LOUVRE SYSTEM

EXTENDED RANGE

The FBLS Fire Block Louvre System (complete set) consists of an FB intumescent block grille only 14mm thick which fits within the door leaf in the door aperture, and an FDLS two-part steel louvre set which fixes to both sides of the door and sandwiches the FB intumescent block. In the event of fire the intumescent starts to expand at 288°C and expands 80 times its own volume to fill the door void preventing the spread of flames.

The FBLS Fire Block Louvre System is suitable for timber fire doors up to 60 minutes and steel fire doors up to 240 minutes integrity (see below for full details). Over twenty-five standard sizes are available from stock including 610x610mm and 457x1524mm (width x height). Any size is available to order from 152x152mm minimum cut-out. Louvre frames are supplied as standard in galvanised mild steel, already grey primed ready for powder coating. Powder coated finishes and stainless steel frames are available to special order. FBLS suits doors of 44mm minimum thickness; there is no maximum door thickness. Fire rated fusible link louvres and standard non-fire rated louvres are also available from stock.

APPLICATIONS

Fire Block Louvre System is designed to be used on fire rated doors to rooms that require ventilation. A standard louvre will allow ventilation but will also allow the passage of flames and smoke, but FBLS will maintain the integrity of fire doors and prevent the spread of flames. Examples of applications are doors to plant rooms, stores, computer rooms, changing facilities and manufacturing areas. In fact, any area that requires ventilation but is protected by a fire rated door.

INSTALLATION

It is designed for doors of 44mm minimum thickness, and on steel doors it will be necessary to fit a reinforcing inverted channel at the bottom of the cut-out to support the FB intumescent block. There is no maximum door thickness, although it will be necessary to provide some lateral support for the 14mm thick FB intumescent block on doors thicker than 44mm.

LOUVRES

The FDLS is an inverted split Y non-vision louvre, manufactured from 18GA cold rolled steel, galvanised and grey primed. It fastens to both sides of the door and sandwiches the intumescent block within the thickness of the door. Full details appear on page 103. The louvre is also available in Grades 304 and 316 stainless steel to special order.

FASTENERS

The louvre frames fasten to both sides of the door using standard #8 x 19mm sheet metal or wood screws through countersunk mounting holes. These are supplied with the louvres. Optional Snake eye or Torx screws are available for applications where security is required on the external face. See page 114.

PRODUCT SPECIFICATION

Material: 18GA Galvanised steel frame and louvre blades.
 Door thickness: To suit minimum 44mm thick doors. No maximum door thickness.
 Free area: 40% free area.

SUITABLE FOR STEEL FIRE DOORS

The FBLS system has been assessed by Warringtonfire for up to four hours integrity in accordance with BS 476-22:1987, up to maximum cut-out sizes of 813x1219mm and 457x1524mm (width x height). The assessment applies to previously successfully fire tested, or assessed by Warringtonfire, or those which are covered by relevant CERTIFIRE certification, steel based fire resisting doorsets which have been shown to be capable of providing up to four hours integrity in the same configuration as that proposed. Warringtonfire Report No C129754 Issue 3 is available on request and should be consulted for a detailed explanation.

SUITABLE FOR TIMBER FIRE DOORS

The FBLS system has also been assessed by Exova Warringtonfire for use **on previously successfully tested timber based fire resisting doorsets in the same configuration as that proposed when including a similarly sized aperture as proposed**, to provide a period of fire resistance of up to 30 or 60 minutes in accordance with BS 476-22:1987 up to maximum cut-out sizes of 610x610mm and 457x762mm (width x height). The previous test must have incorporated an alternative louvre or glazed aperture of the appropriate dimensions (i.e. at least equal to those of the proposed louvre). Copies of WF Report No 146937 and WF Report No 356249 dated 02.09.2015 available on request. The louvres must be installed so that the top of the louvres are less than 1000mm above the doorset threshold (i.e. within the negative pressure area), and the aperture should be lined with Zero FS4004 1.6mm thick intumescent aperture liner (44mm wide on FD30 doorsets and 54mm wide on FD60 doorsets), which should be ordered separately. **No hardwood lipping is required.**

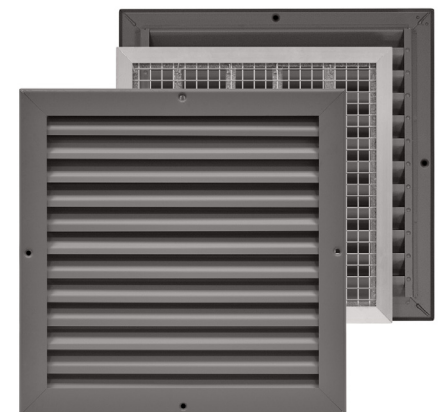
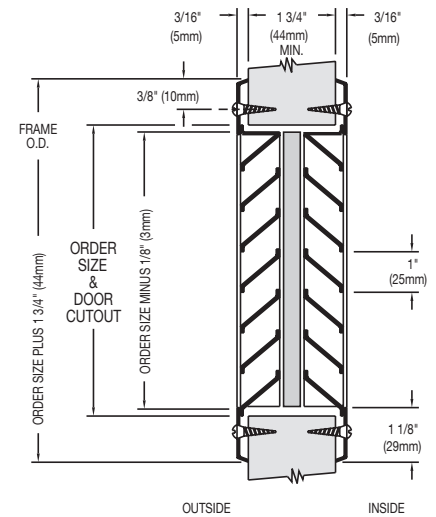
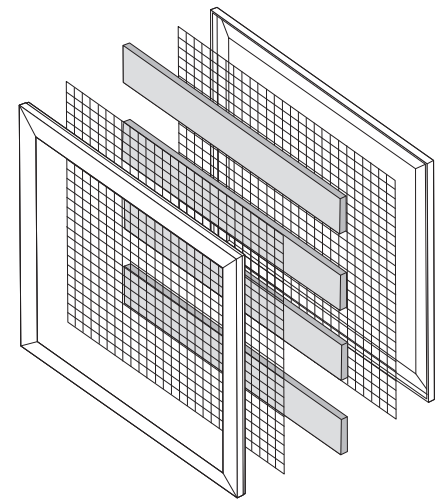

INTUMESCENT APERTURE LINERS	
FS4004 #40621750PSA/8	1.6mm thick x 44mm wide x 2438mm long intumescent
FS4004 #40622125PSA/8	1.6mm thick x 54mm wide x 2438mm long intumescent

FS4004 aperture liners are supplied with PSA pressure sensitive tape to one side, and should be fitted to all four sides of the aperture.

If FBLS is being used on steel fire rated doors, an intumescent aperture liner is not required.