



SHEPHERD LOCK INSTALLATION GUIDE



This guide will help you set up your Shepherd Lock. The process is quick and easy. For a step-by-step video of installation, troubleshooting, and FAQ, visit

www.ShepherdLock.com/support

What You'll Need



1. Standard Phillips-head screwdriver



2. 4 AA alkaline batteries

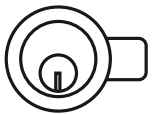

3. Single cylinder dead bolt



Package Contents



1. Mounting bracket



2. Lock Adapter Set
(Adapter, Freezing Block & Mini-Screw)



3. Shepherd Lock Module



4. Module cover



5. Two screws

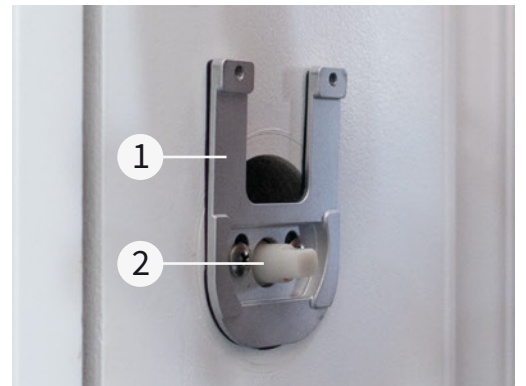

Watch helpful product videos on

[YouTube @Shepherdlock](https://www.youtube.com/@Shepherdlock)

STEP 1

Use a screwdriver to remove the two screws from your deadbolt's existing thumb turn.



STEP 2

Screw mounting bracket into place using the same two screws that previously held your thumb turn in place.

** Do not overtighten screws.*



STEP 3

Select the correct adapter set for your deadbolt brand.

- 1.) Adapter
- 2.) Freezing Block & Mini Screw



STEP 4

Place the adapters in the module and then attach the module onto the mounting bracket.



STEP 5

Install module on mounting bracket using the 2 screws included in product packaging.

** Do not overtighten screws.*



STEP 6

Vertically remove the top compartment. Insert 4 AA batteries and replace.



STEP 7

Place magnetic cover upright over the module.



STEP 8

Download the Shepherd Lock app on iOS or Android and follow the in-app instructions to pair your Shepherd Lock to your smart phone.



For step by step large print, image, and video instructions for installation visit:

www.ShepherdLock.com/support

// TERMS AND CONDITIONS //

Shepherd Lock (Product)

Warranty Statement

1. **Hardware Warranty.** Subject to the additional terms and conditions set forth below, PassiveBolt provides to the original purchase of the Product (whether a person or entity) that acquires the entity from PassiveBolt or an authorized agent or reseller, the limited warranty set forth below. This warranty is only for purchasers in the United States of America.

2. **Limited Warranty.** PassiveBolt warrants the Product against defects in materials and workmanship, but so long as the Product has been used as-intended and under normal conditions and frequency of use, for a period of one (1) year from the purchaser's date of the Product purchase (the "Warranty Period"). If PassiveBolt is notified pursuant to the process set forth below and within the Warranty Period that the Product is defective, and PassiveBolt determines in its sole discretion that the Product is defective, PassiveBolt (or its authorized third party) will either repair or replace the Product with a new Product or refund the price the purchaser paid for the Product. Whether the purchaser will receive a new Product or a refund shall be determined by PassiveBolt in its sole discretion. After the Warranty Period expired, there is no coverage for any Product defects under this limited warranty.

3. **Contacting PassiveBolt.** To make a claim regarding a Product defect within the Warranty Period, the original purchaser must email PassiveBolt at info@shepherdlock.com with reasonable proof of the Product defect that would allow PassiveBolt to determine whether or not there is a defect covered by this limited warranty. PassiveBolt may ask for additional information upon request to verify the alleged defect and the original purchaser must promptly provide such reasonably requested information. After PassiveBolt's review, if the Product is deemed by PassiveBolt to be defective, PassiveBolt will issue the original purchaser a Refund Receipt approving either a refund or shipment of a new Product. If the original purchaser provides the Refund Receipt to PassiveBolt, the defective Product will be shipped (with postage prepaid by the original purchaser), either its original packaging or packaging according an equal degree of protection, to the address provided by PassiveBolt. Failure to return the defective Product with a copy of the Refund Receipt within 15 days after the issuance of the Refund Receipt may result in the forfeiture of warranty coverage for the defective Product. The replacement Product shipped, if applicable, to the original purchaser after their return of the defective Product will be warranted hereunder for a period of one (1) year from shipment. If a refund is authorized, the original Purchaser must provide information for a refund of the Product purchase price (either an address for a check or credit card information for a credit to be applied.)

4. **Limited Scope.** The warranty on the original purchaser's Product is limited to replacement of defective Product or a refund, as detailed above. In no event does the warranty detailed above cover damage to the Product or defects resulting from acts of God, accident, or any user's abuse, negligence, commercial use or modification of, or to any part of the Product, use of the Product other than as intended and designed by PassiveBolt, or any damage or defect caused by any third party product, service or system. Improper use includes use of the Product in improper temperature, humidity or other environmental conditions, or use of the Product in violation of the instructions on use, maintenance, operation or installation of the Product. This warranty does not cover any software or any battery or other consumables provided with or embedded in the Product.



SHEPHERD LOCK USER MANUAL



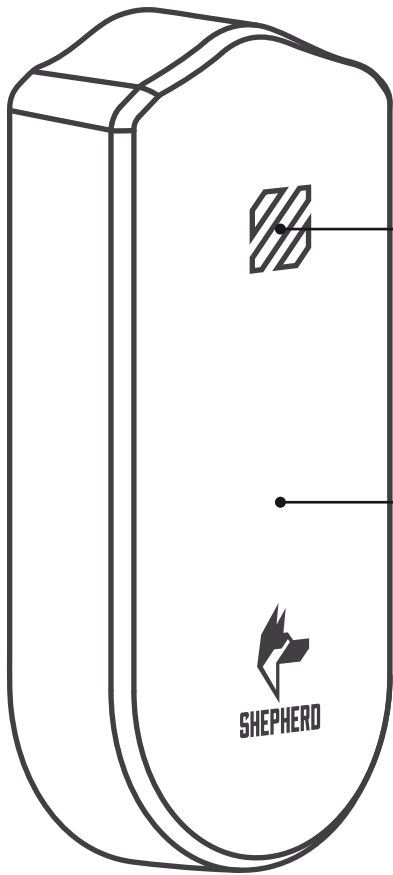

1. LED indicator.

Changes color to communicate with you.

2. Interior Touch Zone.

Used to lock or unlock your door from the interior.



Requires 4 AA Batteries



Compatible with single cylinder deadbolt locks. Not compatible with metal doors.

Shepherd Lock's mobile app is compatible with Android and iOS smart phones, starting at Android 8.0 and iOS 13.0 (iPhone 7).



HOW TO LOCK AND UNLOCK SHEPHERD LOCK AFTER IT IS PAIRED TO YOUR SMART PHONE.

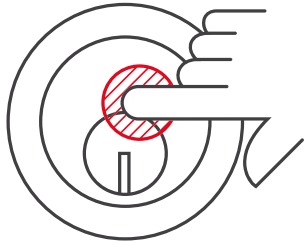

UNLOCK AND LOCK FROM THE EXTERIOR

1. Approach the door with your smart phone.
Recommended phone placement:
in hand or front pocket.
Not recommended: back pocket.
2. Touch the deadbolt with even pressure. Remove fingers once you hear a beep. Lock will unlock after the beep. Do not tap, flick, or hit.

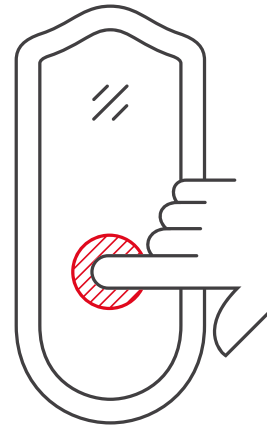

UNLOCK AND LOCK FROM THE INTERIOR

1. Touch the interior touch zone on the Shepherd Lock cover, using even pressure. Do not tap, flick, or hit.
2. Lock LED's will illuminate green or blue to indicate lock status.

REPLACING THE BATTERIES



Track the battery life of your Shepherd Lock in the mobile app to see when it is time to change the batteries.

1. Remove the magnetic cover.
2. Locate the battery compartment in the top of the lock module.
3. Remove the old AA batteries.

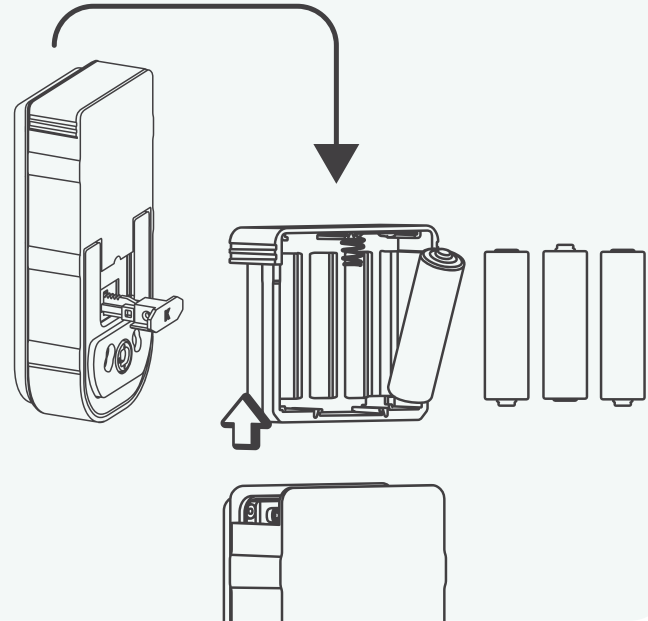

4. Replace them with 4 AA alkaline batteries.
5. Slide the battery compartment back in place.
6. Replace the magnetic cover over the lock module.

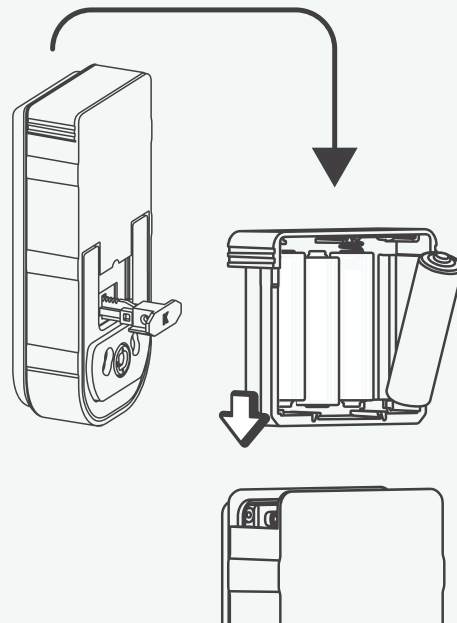

Shepherd Lock gives auditory alerts to indicate various states of the lock. These can be turned off in the mobile app.

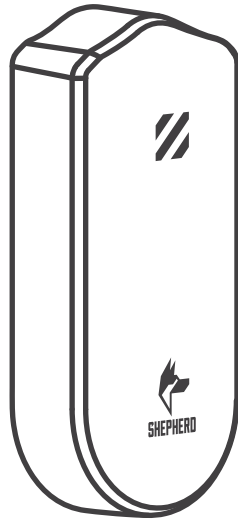

1. Lock
2. Unlock
3. Alarm
4. Interlock (Cover removed/replaced)
5. Error
6. Power On
7. Exterior Touch

LED LIGHT NOTIFICATIONS

Shepherd Lock comes with LED light notifications in the module that indicate the lock status of your door.

GREEN
indicates that
your door is
unlocked.

BLUE
indicates that
your door
is locked.

YELLOW
indicates an error
(ie. an unauthorized
user has touched
your deadbolt).

RED
indicates an
error or a lock
tampering event.

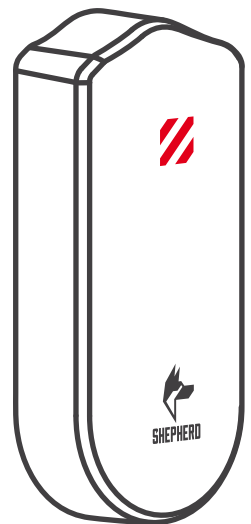
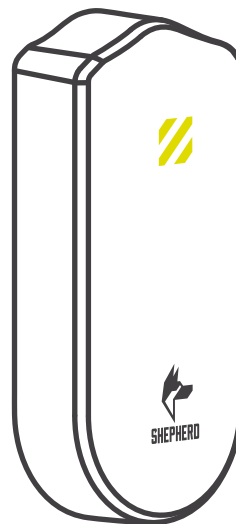
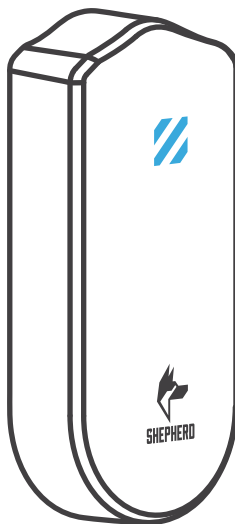
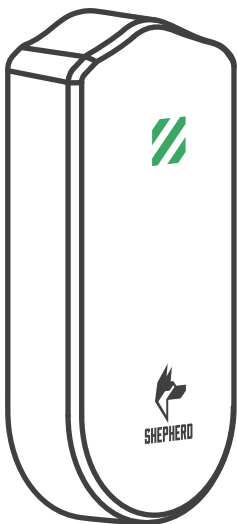

Note: Your lock module will flash blue or green every 10 seconds to indicate lock status.

In-app controls available with Wi-Fi bridge

Access Management

Access History

See who has used their virtual key, the date, and the time.

Key Sharing

Create and schedule temporary virtual keys that are active always, sometimes, or repeating. Cancel keys anytime.

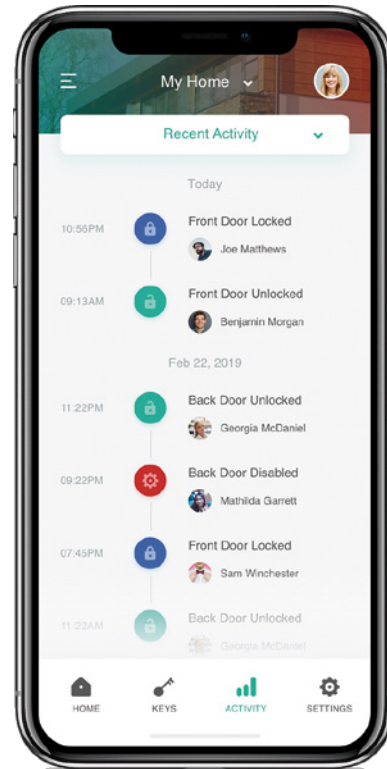

Notifications

Phone notifications can be turned on or off in the settings section of the app.

Home Monitoring

Lock Status

See if your door is locked or unlocked.

Remote Controls

Remotely lock or unlock your door when within Bluetooth range.

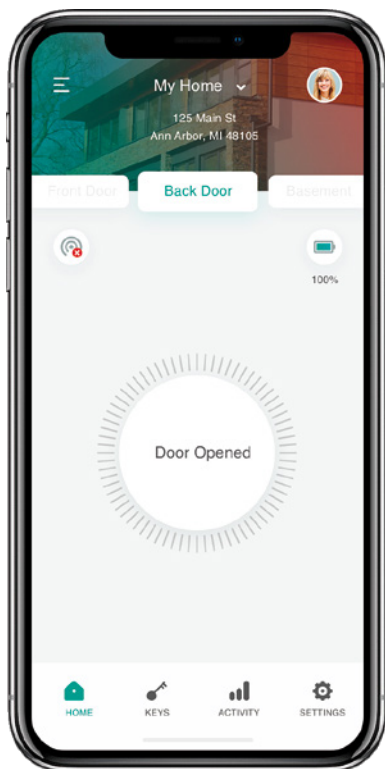
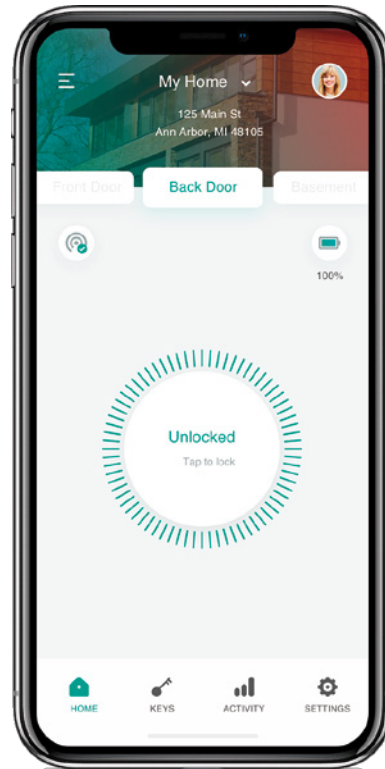

Door Position

Check to see if your door is closed.

Security Features

Authentication

Shepherd Lock authenticates authorized users via a Bluetooth signal sent to the user's smart phone. Once a user is authenticated, Shepherd won't unlock until the user touches the deadbolt.

Security Alert

In case of lock tampering, Shepherd sends a notification to the homeowner's phone and sounds an alarm from the module.

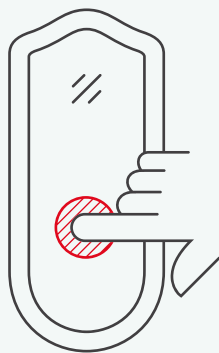
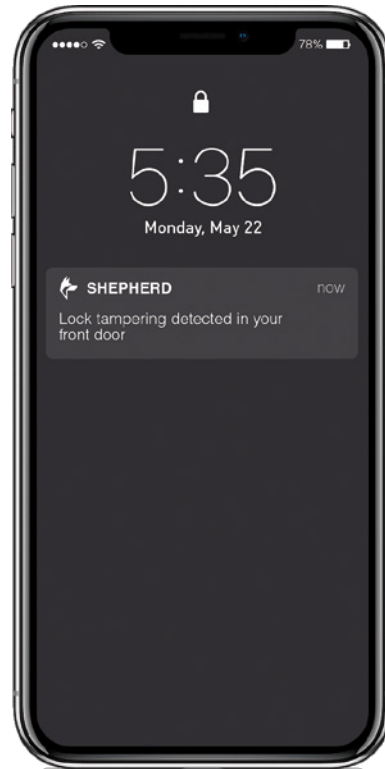

Interior Touch

Anyone can touch to lock or unlock Shepherd Lock from inside the home.



Auto Freeze

In case of persistent lock tampering, Shepherd can temporarily freeze your deadbolt in the locked position, keeping intruders out.

This device contains FCC ID: 2AV6C-GNMOD090004, IC ID: 26054-GNMOD090004.

RF Exposure Notice

This equipment complies with FCC and ISED radiation exposure limits set forth for mobile use environment. Users of this device must ensure that the module be installed and/or configured to operate with a separation distance of 20cm or more from all persons. This transmitter module must not be colocated or operating in conjunction with any other antenna or transmitter.

FCC Approved Antennae

Please see the operational description for details on the antenna approved or use with this module.

TERMS AND CONDITIONS

Shepherd Lock (Product)

Warranty Statement

1. **Hardware Warranty.** Subject to the additional terms and conditions set forth below, PassiveBolt provides to the original purchase of the Product (whether a person or entity) that acquires the entity from PassiveBolt or an authorized agent or reseller, the limited warranty set forth below. This warranty is only for purchasers in the United States of America.

2. **Limited Warranty.** PassiveBolt warrants the Product against defects in materials and workmanship, but so long as the Product has been used as-intended and under normal conditions and frequency of use, for a period of one (1) year from the purchaser's date of the Product purchase (the "Warranty Period"). If PassiveBolt is notified pursuant to the process set forth below and within the Warranty Period that the Product is defective, and PassiveBolt determines in its sole discretion that the Product is defective, PassiveBolt (or its authorized third party) will either repair or replace the Product with a new Product or refund the price the purchaser paid for the Product. Whether the purchaser will receive a new Product or a refund shall be determined by PassiveBolt in its sole discretion. After the Warranty Period expired, there is no coverage for any Product defects under this limited warranty.

3. **Contacting PassiveBolt.** To make a claim regarding a Product defect within the Warranty Period, the original purchaser must email PassiveBolt at info@shepherdlock.com with reasonable proof of the Product defect that would allow PassiveBolt to determine whether or not there is a defect covered by this limited warranty. PassiveBolt may ask for additional information upon request to verify the alleged defect and the original purchaser must promptly provide such reasonably requested information. After PassiveBolt's review, if the Product is deemed by PassiveBolt to be defective, PassiveBolt will issue the original purchaser a Refund Receipt approving either a refund or shipment of a new Product. If the original purchaser provides the Refund Receipt to PassiveBolt, the defective Product will be shipped (with postage prepaid by the original purchaser), either its original packaging or packaging according an equal degree of protection, to the address provided by PassiveBolt. Failure to return the defective Product with a copy of the Refund Receipt within 15 days after the issuance of the Refund Receipt may result in the forfeiture of warranty coverage for the defective Product. The replacement Product shipped, if applicable, to the original purchaser after their return of the defective Product will be warranted hereunder for a period of one (1) year from shipment. If a refund is authorized, the original Purchaser must provide information for a refund of the Product purchase price (either an address for a check or credit card information for a credit to be applied.)

4. **Limited Scope.** The warranty on the original purchaser's Product is limited to replacement of defective Product or a refund, as detailed above. In no event does the warranty detailed above cover damage to the Product or defects resulting from acts of God, accident, or any user's abuse, negligence, commercial use or modification of, or to any part of the Product, use of the Product other than as intended and designed by PassiveBolt, or any damage or defect caused by any third party product, service or system. Improper use includes use of the Product in improper temperature, humidity or other environmental conditions, or use of the Product in violation of the instructions on use, maintenance, operation or installation of the Product. This warranty does not cover any software or any battery or other consumables provided with or embedded in the Product.