

Hatsuyuki *ICE SHAVER*

MODEL HF50DC

Instruction Manual

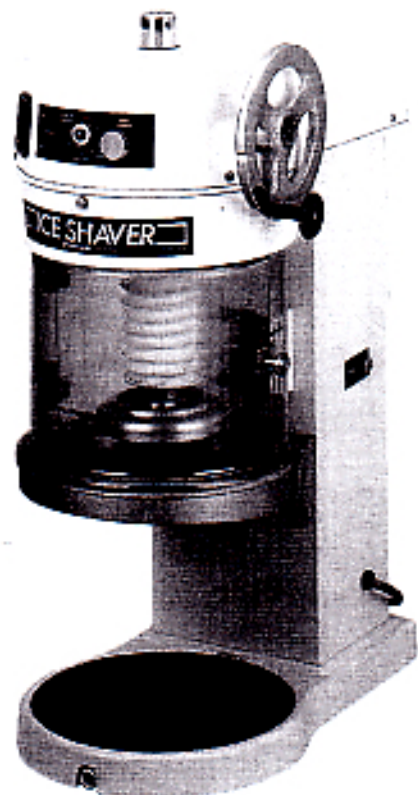

Manufactured by:

CHUBU CORPORATION

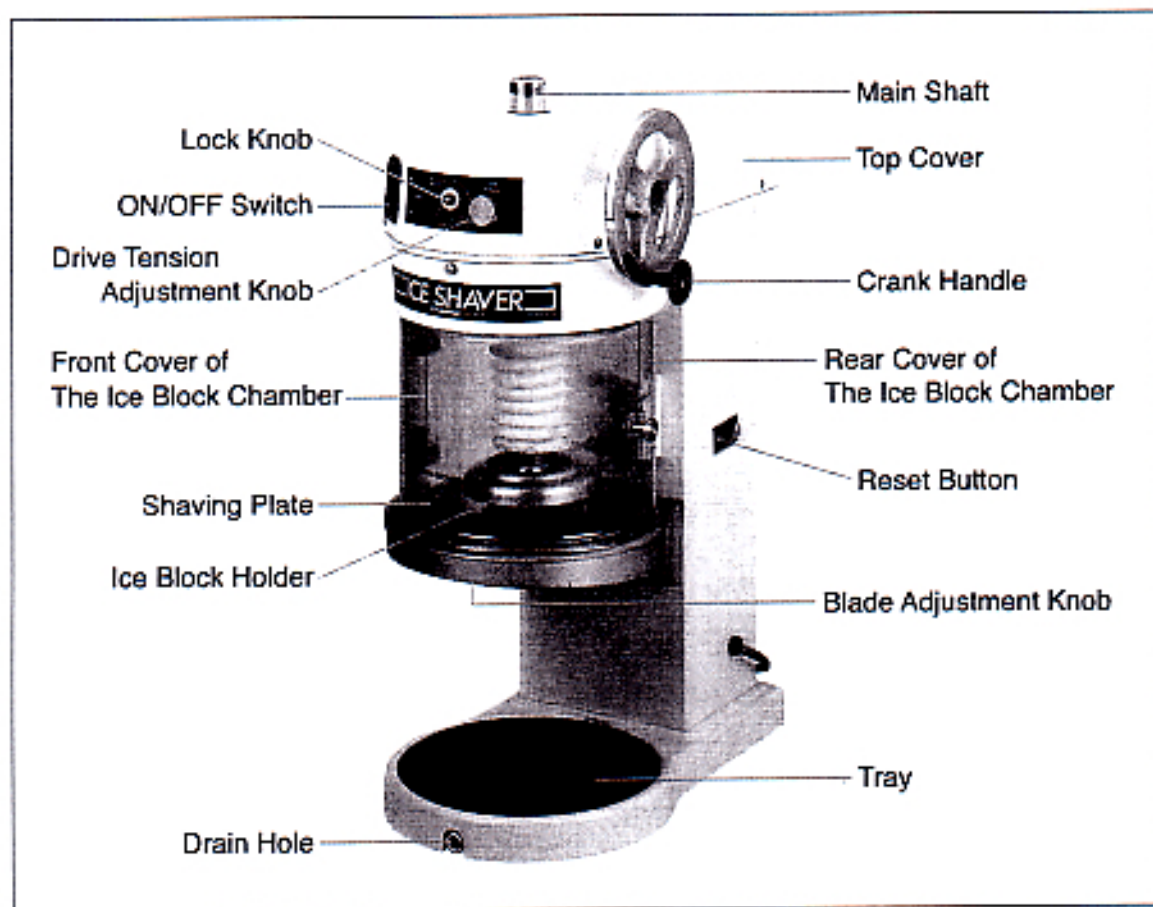

This machine is a DC12V commereial block ice shaver. Trained people should operate it. Keep it away from children to avoid injury or electric shock.

Please be sure to observe the followings to avoid electrical shock:

- Install machine on a sturdy, level, and waterproof surface.
 - Be sure to use a DC12V deep cycle BATTERY.
 - Keep water away from electrical portions of machine.
-

Attention

- When machine is not to be used for many hours, store it in a moisture-free area after it has been completey dried.

● Cable Connection

Machine Battery
Terminal(+) to Terminal(+)
Terminal(-) to Terminal(-)

● Operating instructions

- 1) Place the lock knob at the 'Free' position, and elevate the main shaft to the upper end by rotating the crank handle. Then set the lock knob at 'Lock' position.
- 2) Open the front cover of ice block chamber.
- 3) Place an ice block on shaving plate.
- 4) Place the lock knob at the 'Free' position, and lower the main shaft by rotating the crank handle until the prongs are imbedded in the ice.
- 5) Close the front cover of ice block chamber.
- 6) Turn blade adjustment knob counter-clockwise until it comes to a stop.
- 7) Turn on the power switch. The motor will not start while the front cover is open.
Turn on the power switch after the front cover is closed.
- 8) Slowly turn the blade adjustment knob clockwise slowly and adjust fineness of shaved ice.

● To stop shaving

Turn off the power switch.
(Be sure not to open the front cover to stop shaving.)

● Overload protection

The unit automatically shuts off power when the motor is overloaded. In this case, set the power switch to OFF and remove the cause before pushing the reset button.

● Adjusting shaving size

For coarser shaving, turn blade adjustment knob clockwise.
For finer shaving, turn the knob counter clockwise.

● Blade removal and replacement

See Instruction for dismantlement, cleaning and sterilization.

● Drive tension adjustment knob

This knob adjusts the "power" to press and hold the block ice. Turn the knob clockwise and the power will be larger and counter clockwise the power will be smaller. Adjustment is correct when light proper resistance is felt when raising or lowering crank. If the power to press hold the ice is not enough, this will cause the ice not to shave well or to jump out of the chamber. If the power is too strong, it will cause the drive gear to be worn out or the ice to crack.

● Cleaning

Dismantle and clean after daily operation according to the following instruction.

- 1) Disconnect the cord from BATTERY.

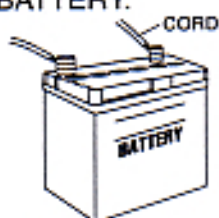

- 2) Open the front cover of the ice block chamber and remove the cover by lifting upward.

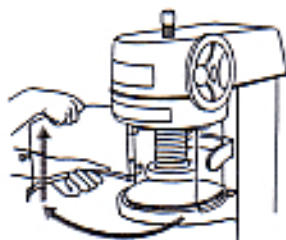

- 3) By rotating crank handle, elevate the ice block holder to the middle position.

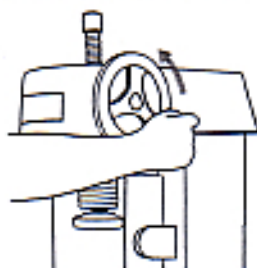

- 4) Turn the Lock knob clockwise and lock the main shaft.

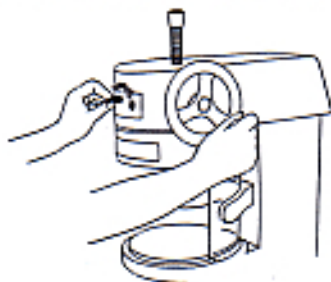

- 5) By holding the upper end of main shaft, turn the ice block holder at the other end of the shaft counter-clockwise and remove it from the main shaft.

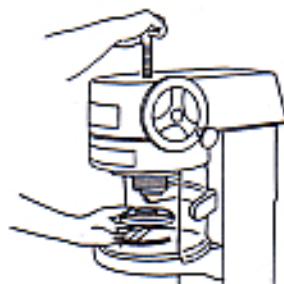

6) Dismantle the ice block holder assembly as follows:

- Take out ice block holder A and B.

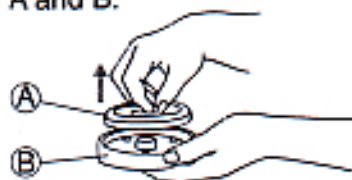

- Pull out (12pcs) ice block holder nails upward.



7) Place Lock knob at 'Free' and elevate the main shaft to the upper end position by rotating the crank handle. Then set the Lock knob locked.

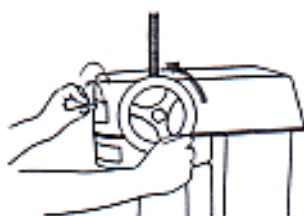

8) Unscrew the fitting screw and remove the rear cover of the ice block chamber by turning counter-clockwise.

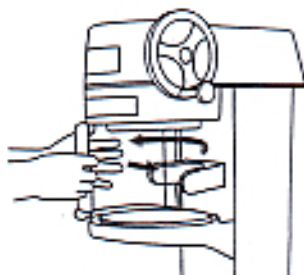

9) Remove wing bolts (2pcs) fastening shaving plate at back of the plate. Raise the shaving plate and remove it.



10) Dismantle the blade assembly as follows.

- Unscrew the (2) blade fastening screws and remove blade and blade holder.

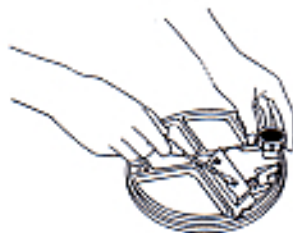

- Remove the blade adjustment knob and washer by turning the knob clockwise.



- Unscrew the (2) screws fastening blade assembly to shaving plate and remove blade assembly.

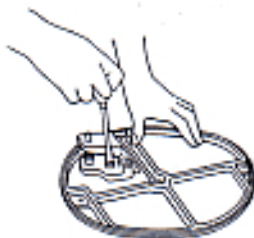

- Dismantle blade assembly-consisting of base plate, stopper ring, spring, blade fitting plate and blade fitting plate shaft.

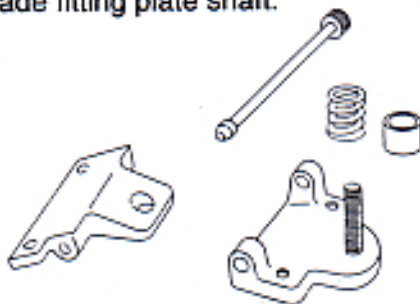

- Clean the disassembled parts by lukewarm water with neutral dish detergent, rinse them by water, and wipe out.

* After finishing cleaning and sterilization, lay parts at a dry place.

- Reassemble the unit in reverse order of disassembly.

● Cleaning The Exterior

Wipe with a clean dry, soft cloth. For heavy dirt, wipe with a cloth dampened with dish detergent diluted with warm water. Remove detergent residue with a soft cloth. Do not clean with harsh detergents, solvents, or abrasive cleaners.

● Oiling

Shaft must be kept lubricated once or twice a month.

● Caution

Be sure to disconnect the battery, before oiling.

Do not use vegetable oil for lubrication as it hardens and prevents the main shaft from turning.

- 1) Completely raise the main shaft and apply a few drops of oil from the top.

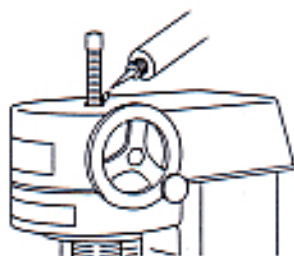

- 2) For oiling the crank, remove head cover and oil through the two small oiling holes located on the upper part of the bearing.

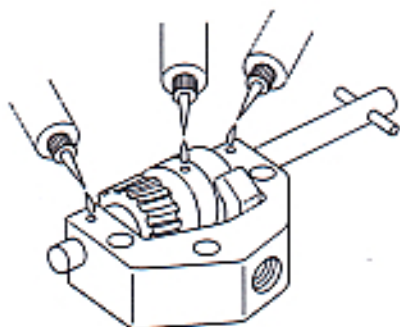

- 3) Use gear oil for oiling. Other mineral oil, such as machine oil can also be used.

● How to change blades

● Warning

When loading/unloading ice, cleaning, checking, Changing Blades, be sure to first turn off the power switch and always wear gloves. Do not touch blades.(It can cause injury.)



1) Removing Blades

- Open the sliding front cover by moving/sliding to left.
- Turn block ice holder wheel counter-clockwise to raise the drive shaft.
- Take your hand from block ice holder wheel and make sure that the ice block holder does not descend.
- Loosen (2) set screws with a phillips screw driver.
- Remove blade from shaving table.

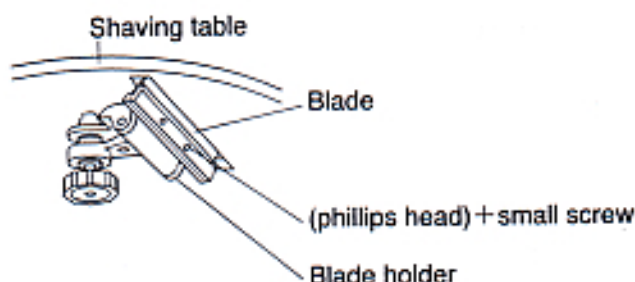

2) Installing Blades

- Turn left blade adjustment knob completely, then turn back one half turn.
- Insert new blade from the top of the shaving table.
- Set the blade edge so that cutting edge is parallel to the plane of the shaving table.
- Fix blade in place, using 2 set screws.

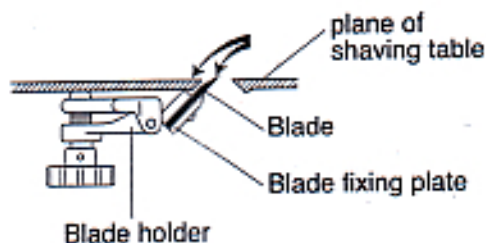

● **Trouble shooting**

SYMPTOMS:

1. **Main shaft fails to turn when motor switch is in the ON position.**

- a) **NO power to the machine-check outlet or cord.**
- b) **Moter drive belt broken-replace belt.**
- c) **Front cover is open.**

2. **Main shaft is turning, but the ice is not shaved properly.**

- a) **Improper blade adjustment-see blade adjustment section.**
- b) **Dull blade-sharpen or replace blade.**

Sharpening Procedure:

- 1. **Remove blade from machine.**
 - 2. **Lay blade on the edge of a flat surface, with tapered side forward. Sharpen the blade with a sharpening stone.**
 - 3. **Turn blade over. De-burr backside of blade by a sharpening stone. Repeat process if necessary. Test sharpness by cutting through a thin sheet of paper.**
- c) **Improper drive tension adjustment (not enough pressure applied to ice). Increase tension by turning tension adjustment screw clockwise. Tension is property adjusted when a moderate amoderate amount of resistance is felt when raising or lowering the crank.**

● Specifications

Dimensions	: $12\frac{23}{32}" \times 17\frac{5}{32}" \times 25\frac{3}{16}"$ (W×D×H)
Electrical	: 12V DC 9.0A 110W
RPM	: 250 rpm
Output	: 100 W
Shaving Capacity	: 4.4 lbs/minute
Ice Block Capacity	: $5\frac{3}{16}" \times 5\frac{3}{16}" \times 5\frac{7}{16}"$
Shaving plate diameter	: $8\frac{5}{16}"$
Weight	: 67 lbs (32.5kgs)

● Accessories

Tray	1
Extra blade	1
Gear oil	1

Manufactured by:

CHUBU CORPORATION

Kuwana, Mie, Japan.

PRINTED IN JAPAN