



CORENINE 8830 MASSAGE CHAIR

Thank you for purchasing the 8830 Massage Chair. Please read the contents of this manual before using your chair and refer to it when needed.

TECHNICAL SPECIFICATIONS

Model Number: 8830

Rated Voltage: 110v

Rated Power: 180w

Net Weight: 278 lbs Weight Capacity: 285 lbs

© 2022 CORENINE

The images in this manual are for reference purposes and may not resemble the massage chair design you purchased. CORENINE reserves the right to make changes to the information in this document, including and without limitation the specifications and product descriptions at any time and without notice. No medical claims are warranted or implied by the use of this product.

WARRANTY

CORENINE'S 8830 Massage Chair has a 2 year parts and 2 year in-home/in-shop service warranty.

To activate your massage chair warranty go to corenineusa.com > Support > Product Registration.

A 5 year extended warranty can be purchased on our website at corenineusa.com > Support > Warranties > 5-Year Extended Warranty.

To view and download warranty information go to corenineusa.com > Support > Warranties > 8830 Standard Warranty.

CONTENTS

PRODUCT AND ACCESSORIES	1
CHAIR REQUIREMENTS	2-3
SAFETY & MEDICAL PRECAUTIONS	4-6
CHAIR INSTALLATION	7-8
REPLACING A FUSE	8
STORING THE CHAIR	8
REMOTE CONTROL	9
TROUBLESHOOTING	10
CLEANING & MOVING THE CHAIR	11

PRODUCT & ACCESSORIES

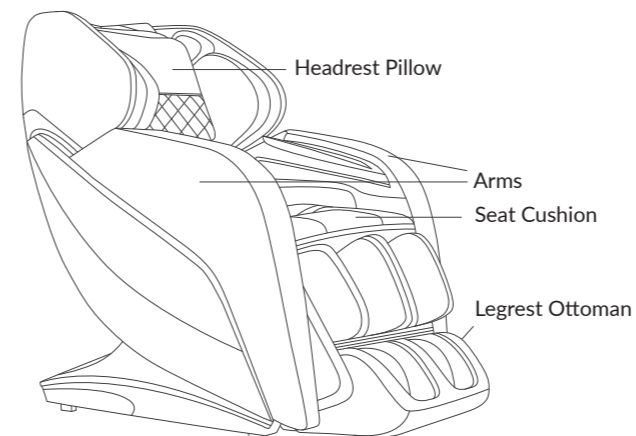

MASSAGE CHAIR

Includes remote control, two arms, headrest pillow, seat cushion, and legrest ottoman.



POWER CORD



QUICK START GUIDE

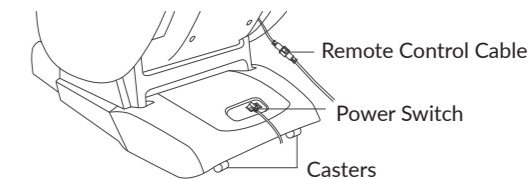

CHAIR REQUIREMENTS

WALL CLEARANCE

When the massage chair is fully reclined it requires 2 inches of space behind it and 8 inches of space in front of it. Place the chair at least 40 inches away from audio and video devices (e.g. TV, radio) to prevent signal interference.

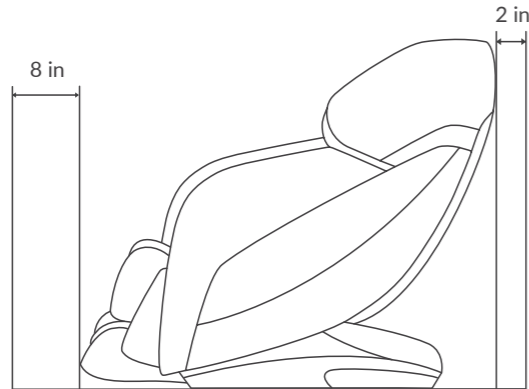

CAUTION

- Check to make sure the power cord is not knotted, entangled with any objects, or crushed under the massage chair.
- Keep children and pets away from the chair as it reclines and returns to the upright position.
- Make sure the chair is in the upright position before sitting down.

SURROUNDING ENVIRONMENT



- Do not place this chair in direct sunlight or near an open flame or high temperature sources.
- Do not place this chair near damp or moist areas such as swimming pools or bathrooms.

CHAIR REQUIREMENTS

GROUNDING PRECAUTIONS

 **DANGER:** To reduce the risk of electric shock

WARNING! An improper connection of the equipment-grounding conductor can result in a risk of electric shock. This chair must be connected to a properly grounded outlet. Grounding provides a path of least resistance for electrical current to reduce the risk of electric shock if the product malfunctions or breaks down. This chair is equipped with a cord having an equipment-grounding conductor and a grounding plug. If you are in doubt as to whether this product is properly grounded, do not modify the plug provided with this chair. Contact a qualified electrician to install a proper outlet.

- The electric cord must be plugged into an appropriate outlet that is properly installed and grounded in accordance with all local codes and ordinances.
- The chair must be connected to an outlet having the same configuration as the plug.
- No adapter should be used with this chair.
- Always unplug this chair from the electrical outlet immediately after using and before cleaning.

 **WARNING**

Make sure the chair is fully assembled with the legrest on the floor before plugging the chair into an electrical outlet.

POWERING UP THE CHAIR



Plug the power cord into an electrical outlet and press the power button (located on the back of the chair) to the ON position. Next, press the power button on the remote control.

IMPORTANT SAFETY PRECAUTIONS

Read all of these instructions before using your massage chair.

SAFETY WARNINGS



DANGER

- This massage chair should only be used for its intended purpose as described in this manual.
- To disconnect, turn all controls to the OFF position before unplugging the chair.
- **NEVER** attempt to repair or modify any electrical or mechanical functions in this chair.
- **NEVER** operate this chair if it has a damaged power cord or plug, if it is not working properly, if it has been dropped or damaged, or dropped into water.
- Do not place the power cord near heated surfaces, under heavy objects, or in high traffic areas.
- Do not remove the plug from the outlet while the chair is operating.
- Do not use the chair if the electrical outlet is loose.
- To avoid electric shock, **NEVER** use wet hands to connect or disconnect the power plug from the electrical outlet, and never use the massage chair when your body is wet or damp.
- If you spill liquid onto the chair, immediately turn off the chair and unplug the power cord.
- Do not operate this chair where flammable products are being used such as aerosol sprays or oxygen.
- Do not put hands or fingers near the rollers when the massage mechanism is operating. Injury may result from rollers squeezing together.
- Always confirm that there are no obstacles behind the chair and that there is sufficient space to recline.
- Keep children and pets away from the chair when in use.
- Close supervision is necessary when this chair is used by, on, or near children, invalids, or disabled persons.
- Do not operate this chair under a blanket or pillow. Excessive heating can occur and cause fire, electric shock, or injury.

IMPORTANT SAFETY PRECAUTIONS

Read all of these instructions before using your massage chair.

SAFETY WARNINGS



DANGER

- Do not use the chair if it is damaged or if the covering shows any sign of deterioration, such as peeling or cracking, or if the fabric is torn or the internal components exposed.
- Do not use any attachments that are not included with this chair.
- Never drop or insert any object into any opening.
- Do not place or use this chair outdoors.
- When using this chair after it has been in storage, check to see that it is operating properly prior to use.
- Do not stand on the massage chair or the legrest ottoman. Use only while seated.

MEDICAL PRECAUTIONS



WARNING

- **DO NOT USE THIS CHAIR** if you have a pacemaker or other medical electronic devices inside your body.
- Do not use this chair without consulting your physician if you have a medical condition.
- This chair is not intended for self-treatment of medical conditions that should be managed by a qualified health care provider.
- Do not massage any area of the body that is swollen, inflamed, or has skin eruptions.
- Do not use on unexplained leg or calf pain, or if you've been diagnosed with deep vein thrombosis.
- If you feel any abnormal discomfort while using the chair, stop use and consult your physician.

IMPORTANT SAFETY PRECAUTIONS

Read all of these instructions before using your massage chair.

PROHIBITED ACTION THAT MAY VOID WARRANTY

CAUTION

- Any modification, disassembly, maintenance, or repair of the chair by anyone other than an approved service professional will void the warranty. Contact your retail provider if your chair is in need of service.
- Do not use any attachments that are not included with this massage chair.
- Do not remove the seat cushion or tamper with the massage mechanism.
- Do not allow children or pets to play near the chair during operation.
- Only one person at a time should use the massage chair. The maximum weight load for this chair is 285 lbs.
- Do not use this chair outdoors or in excessively hot, humid or dusty environments.
- Do not place this chair directly in the sun or near an open flame.
- Do not place this chair near damp or moist areas such as swimming pools or bathrooms.
- Do not place heavy objects on the chair.
- Do not stand on the massage chair. Use only while seated.
- Do not stand or sit on the armrest or legrest.
- Do not exert force on the massage rollers when the massage mechanism is operating.
- Do not operate under a blanket, pillow or electric blanket.
- Do not use this chair while smoking.
- This massage chair is only intended for personal in-home use. Commercial use will void warranty.

CAUTION

The wear and tear of the legrest footwells results from users leaving their shoes on, and this is **NOT COVERED BY THE WARRANTY.**

CHAIR INSTALLATION

- 1 Manually lower the legrest.

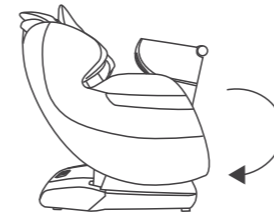

ARMREST INSTALLATION

- 2 Connect the color coded air hoses on armrests to the main body. Route hoses inside of chair frame.



- 3 Align armrest mounting holes to main body mounting holes.



CUSHION INSTALLATION

- 4 Align armrest square frame to main body frame. Press down on top of arm to engage.

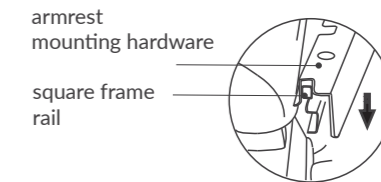

- 5 Secure front of arm to main body with screws and brackets provided. Next, secure top of arm to main body and install the trim panel.

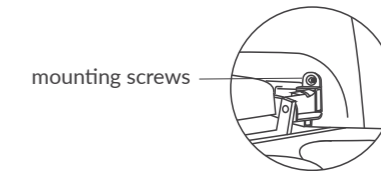

- 6 Remove all of the fabric velcro protectors on the chair, and velcro the back and seat cushion in place.



CHAIR INSTALLATION

- 7 Attach the top of the back cushion with the zipper.

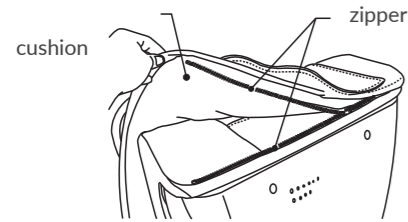

- 8 Connect the remote control wires and secure with the threaded nut.

Align the interior groove patterns and connect both ends of the remote control cable.

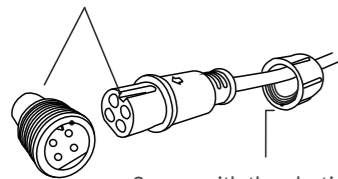

Secure with the plastic thread cap.

REPLACING A FUSE

To replace a fuse, turn the power control button to the OFF position and unplug the power cord. Remove the fuse cover lid and replace with the same sized fuse.

Contact a qualified electrician if you are unable to replace the fuse.

WARNING! Check with a qualified electrician or serviceman if you are in doubt as to whether your chair is properly grounded.

STORING THE CHAIR

- Cover the chair while it is in storage.
- Do not store the chair outdoors or in direct sunlight.
- Do not store the chair in excessively hot, cold, humid, damp, or dusty environments.

REMOTE CONTROL

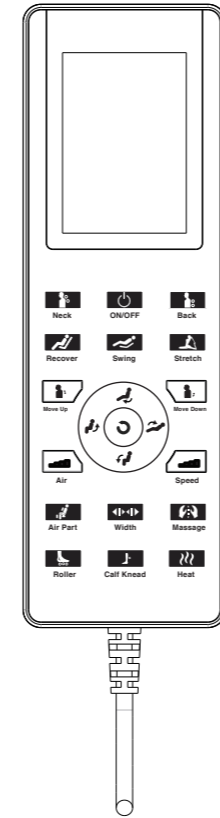

- Neck, Shoulder & Upper Back Auto Massage.
- Press to turn the massage chair ON and OFF.
- Lower Back Auto Massage
- Recover Auto Massage: A high intensity massage that loosens the muscles.
- Swing Auto Massage: A relaxing rocking massage that promotes sleep.
- Stretch Auto Massage: A high intensity stretching massage.
- Press and hold to RAISE the backrest.
- Press and hold to RAISE the legrest.
- Press and hold to LOWER the backrest.
- Press and hold to LOWER the legrest.
- Press to return the chair to its upright position.
- Press and hold to RAISE the back roller position.
- Press and hold to LOWER the back roller position.
- Press to adjust the speed of the massage.
- Press to adjust the air bag intensity.
- Air Bag Function:** Press to activate/deactivate the air bag function in various zones.
- Width Function:** Press to adjust the width of the back roller when the shiatsu, tapping, and rolling massage modes are functioning.
- Massage Mode Function:** Press to cycle through the six massage modes (kneading, kneading/tapping, knocking, rolling, shiatsu, tapping). Press a seventh time to stop the back massage and only receive a foot, calf, and arm massage.
- Roller Function:** Press to turn the legrest rollers ON and OFF.
- Calf Function:** Press to change modes and/or turn off calf function.
- Heat Function:** Press to turn the heat function ON and OFF.
- * PLEASE NOTE:** When the massage is complete, or if the massage has timed out, press the center button to return the chair to its upright position.

TROUBLESHOOTING

PROBLEM	POSSIBLE REASON FOR PROBLEM	TROUBLESHOOTING
There are sounds inside the massage chair when it is being used.	The air pump, motor and mechanical parts of your massage chair will make various beeping & humming sounds.	This is normal.
The massage chair suddenly stops working when it is being used.	The massage time may be complete.	Choose a new massage mode or turn off your massage chair.
	Your electrical power may have stopped working.	Check to make sure your power is connected.
The massage chair is connected to the power supply but the remote control is not working.	The power switch may not be turned on.	Turn on the power switch.
	The "On/Off" button on the remote control may not be turned on.	Turn the "On/Off" button on the remote control to the "On" position.
	The power cord plug may not be properly connected to a working electrical outlet.	Reconnect the power cord plug to a working electrical outlet.
	A fuse may have burned out.	Replace the fuse.
	The power cord may be damaged.	If damaged, contact your retailer's service department for a new power cord.
The massage chair becomes louder when it is being used.	The massage chair may be overloaded from extended use.	Turn off the massage chair for at least 30 minutes.
The massage chair will not extend, recline or return to its upright position.	There may be obstacles in the way.	Remove the obstacles.
	The massage chair may be overloaded from extended use.	Turn off the massage chair for at least 30 minutes.



ATTENTION

If you continue to have problems, turn off the main power switch, unplug the power cord from the electrical outlet and contact your retailer's service department or CORENINE at corenineusa.com.

CLEANING INSTRUCTIONS



WARNING

- Turn the main power switch off and disconnect the power plug from the electrical outlet before cleaning the chair to reduce the risk of electric shock.
- Never use wet hands to connect or disconnect the power plug from the electrical outlet.
- Do not use a damp cloth to clean the power cord.

SYNTHETIC LEATHER CARE

- For general cleaning, wipe down the leather with a damp cloth, then a dry cloth.
- Avoid excessive brushing or rubbing while cleaning the leather.
- To remove stains, use a damp cloth with a 3-5% neutral detergent, then wipe with a dry cloth.
- Do not use benzene, thinner, alcohol, or any other solvent or abrasive cleansing agent on the leather.

PLASTIC CARE

- Use a damp cloth with a 3-5% neutral detergent to clean the plastic components of the massage chair.
- Dry with a cloth or allow to air dry.

TABLET REMOTE CONTROL CARE

- Do not use a damp cloth to clean the remote control. Use only a clean dry cloth.
- Do not use benzene, thinner, alcohol, or any other solvent or abrasive cleansing agent on the remote control.

MOVING THE MASSAGE CHAIR

The massage chair can be moved by raising the front of the chair and tilting back on the wheels.

- Unplug and remove the power cord and remote control before moving the chair.
- Use caution when handling the armrests and legrest ottoman to avoid damage.
- Use caution when rolling the chair across a tile or wood floor.
- To prevent the floor from being scratched, it is recommended that you place a towel or blanket under the wheels or lift the chair using at least four people.
- The chair should be placed on a flat level surface and away from damp rooms (i.e. bathrooms) and open flames (e.g. stove, fireplace).
- It is recommended that you place a soft mat underneath the chair to protect your floors.