

NEW - Extended Range
with Stainless Steel Options

HepcoMotion®



Precision Ring and
Track System



This catalogue interacts with the HepcoMotion website



www.HepcoMotion.com



Additional information is available where you see this icon



Data sheet number

From HepcoMotion home page



Literature



PRT2

On this web page are the datasheets referred to in this catalogue, plus information on new additions to the PRT2 range and downloads for the catalogue and catalogue amendments.

Introducing the HepcoMotion® PRT2 Precision Ring and Track System

HepcoMotion has been solving Customers' circular motion problems for many years, building an indispensable knowledge of applications and clever technical solutions. This knowledge coupled with extensive research and development has resulted in the introduction of a comprehensive range of precision ring slides and track systems to suit virtually every need. Based on the highly successful PRT product the new PRT2 system offers a greatly expanded range of sizes and options including stainless steel availability as standard. The Precision Ring Slide and Track System products compliment Hepco's highly successful and extensive range of linear motion products, enabling customers to choose a single source for all their motion guidance requirements.

Features & Benefits

Common

- Friction-free motion.
- Stainless steel options.
- Fully adjustable.
- Tolerant of debris.
- Simple and effective means of lubrication.
- Zero play.
- Works in any plane.
- Tolerant of misalignment.
- Easy to install.
- 2D & 3D CAD files available.







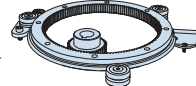

Ring Slides and Segments

- Circular motion control at the periphery where it is needed.
- Large hollow centre to accommodate other components (ring slides).
- Precision flat surface for mounting ancillary components (ring discs).
- Will track the curvature of cylindrical shapes.
- Gearcut options for ease of driving.
- Double edge and single edge versions available.
- Carriage brake available.

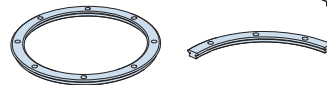
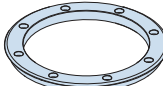
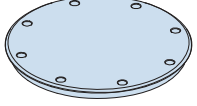
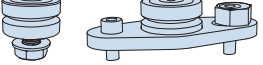
Track Systems

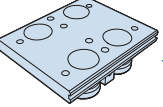
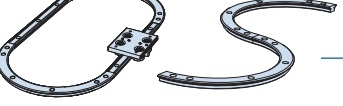
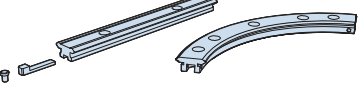
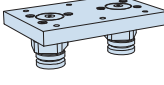
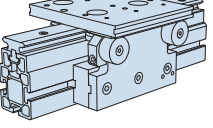
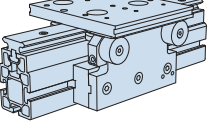
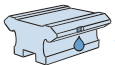
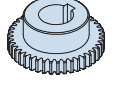
- Limitless variety of circuits available.
- Precision positioning system available.
- High load support option at work stations.
- Simple alignment facility provided.
- Various carriage plate options.
- Components available for driving.
- Support frame available.

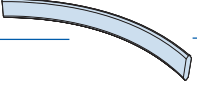
Contents

System Composition		2-7
Application Examples		8-19
Full Size Illustrations for Initial Selection		20-21
Assembled Ring System		22-25
Double Edge Ring Slides and Segments		26-27
Single Edge Ring Slides and Segments		28-31
Rings Discs		32-33
Bearings		34-36
Lubricators		37
Fixed Centre Carriages		38-39
Track Systems		40-41
Track System Straight Slides and Curved Segments		42-46
Bogie Carriages		47
Moment Load Carriages		48-49
Driven Track System Components		50-51
Bleed Lubrication		52
Pinions		53
Technical Section		54-58
Technical Specifications		59
Rolled Rings, Segments & Specials		60
Related Products		61

System Composition

The HepcoMotion PRT2 system comprises of a comprehensive range of ring slides, ring segments, bearings and ancillary components which provide a versatile solution for most rotary and track system applications. A large range of ring slide types in various diameters are available in both steel and stainless steel with hardened V edges. Stock 90° and 180° segments are also available. Gear cut versions are available with pinions to provide a simple and effective means of driving. An overview of the comprehensive product range is shown  2 - 7.

Double Edge V Ring Slide 26-27

- Bearings can be mounted internally and externally.
- Carriages can be run on double edge rings.
- Precision ground all over for high accuracy and conformity.
- Large hollow centre to accommodate other components.
- Datum register faces provided internally and externally for ease of location.
- Internal/External gear cut options available for ease of driving.
- V edges hardened for maximum wear resistance.
- Soft centre section allows customising.
- Stainless steel option available as standard.
- Through hole fixing or tapped hole fixing.
- Comprehensive range of drive pinions available  53.

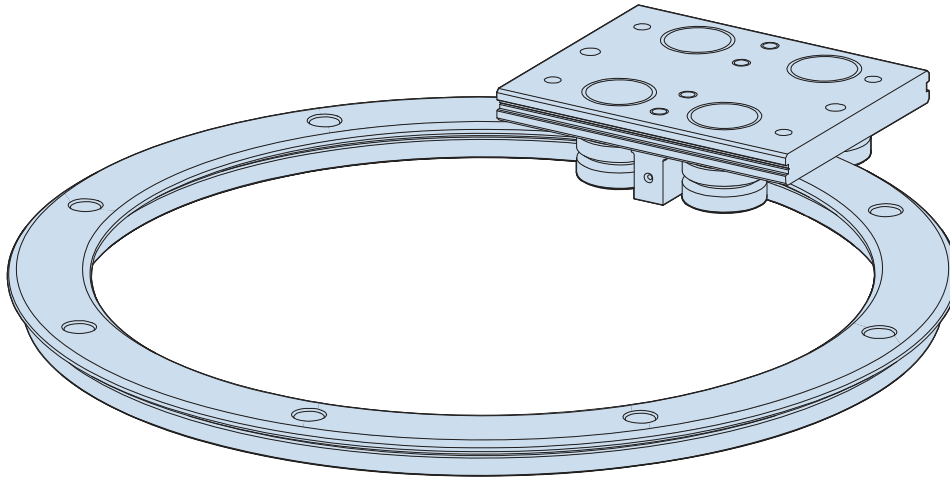

V Ring Segments 26-31

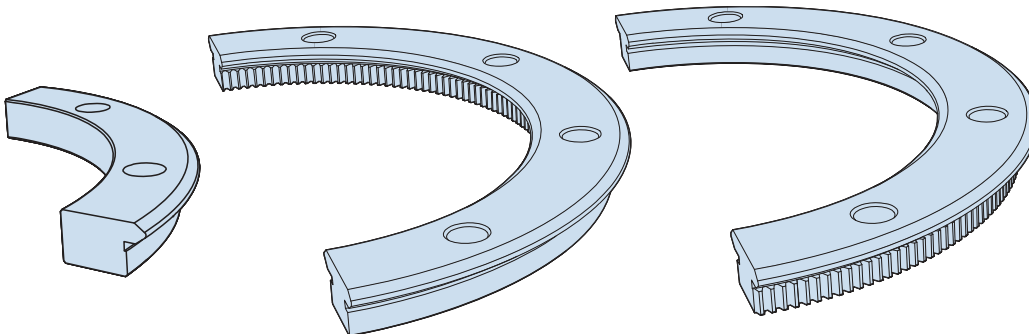

- 90° and 180° segments available as standard.
- Double edge V and single edge V ring segments available as standard.
- Special length segments available to order.

Single Edge External V Ring Slide 28-29

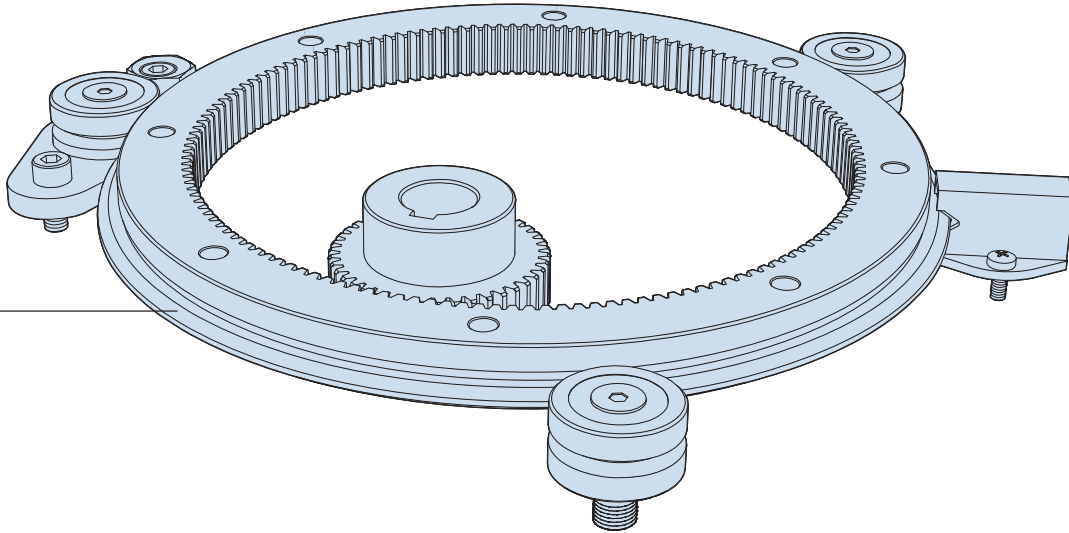

Common features

- Narrow section width.
- Datum register face for ease of location.
- Large gear size and face width.
- Stainless steel option available as standard.
- V face hardened for maximum wear resistance.
- Soft centre section allows customising.
- Manufactured from high quality steel.
- Choice of external or internal V.
- Precision ground all over for high accuracy and conformity.
- Through hole fixing or tapped hole fixing.
- Can be used in any orientation.
- Comprehensive range of sizes.
- Comprehensive range of drive pinions available  53.

Single Edge Internal V Ring Slide 30-31

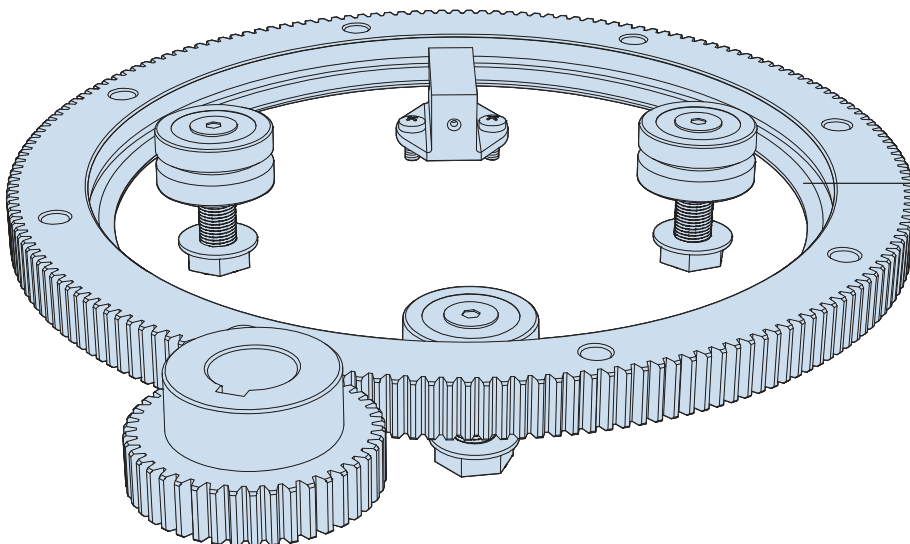

System Composition

HepcoMotion bearings are available in a range of 5 useful sizes and various formats to suit most design requirements. The special raceway conformity and low radial clearance make these bearings particularly suited to ring slide applications. All bearings are lubricated for life internally and are available with metal shields for exclusion of particulates and low friction running or, with nitrile seals to inhibit ingress of liquids. Bearings are also available in stainless steel fitted with nitrile seals.

- **Through hole fixing bearing (concentric)**  34-35

- * **Through Hole fixing bearing (eccentric)**  34-35

- Provides datum reference for the system.
- Short fixing stud for thin carriage plate.
- Long fixing stud for thick carriage plate.
- Controlled height option for enhanced system height accuracy. Provides simple means of adjusting via centre hexagon or socket in stud.
- Eccentric adjustment sufficient to allow removal of the ring or carriage without disassembly.

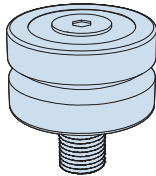
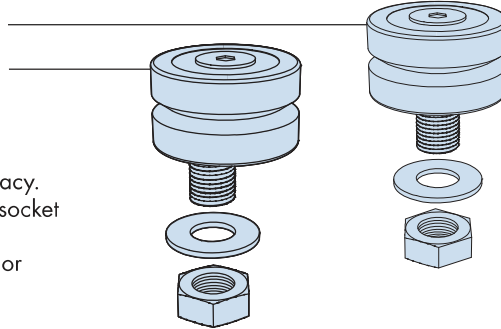

- **Blind hole fixing bearing (concentric)**  34-35

- For mounting into thick plates or where access to opposite side is restricted.
- Provides datum reference for the system.
- Controlled height option for enhanced system height accuracy.

- **Blind hole fixing bearing (eccentric)**  34-35

- For mounting into thick plates or where access to opposite side is restricted.
- Adjustable from operating side for ease of access.
- Controlled height option for enhanced system height accuracy.
- Easily removed to allow removal of ring.

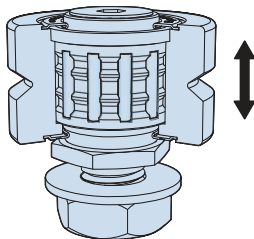
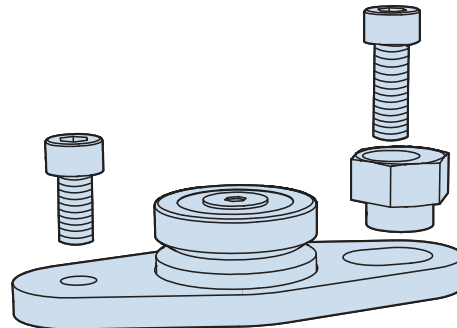

- **Floating bearing (concentric & eccentric)**  36

- Axial float of outer race accommodates variation in system height.
- Provides simple means of adjusting via centre hexagon or socket in stud.
- Short fixing stud for thin carriage plate.
- Long fixing stud for thick carriage plate.
- Double eccentric version has sufficient adjustment to allow removal of the ring or carriage without disassembly.

- *** Double Row Bearing / Twin Bearing**  34-35 ●

- Twin bearing for tolerance of misalignment and smooth running.
- * Double row bearing for tolerance of debris and higher load capacity.
- Special raceway conformity and low radial clearance, for slide ring applications.
- General quality to ISO Class 4. Aspects to Class 2.

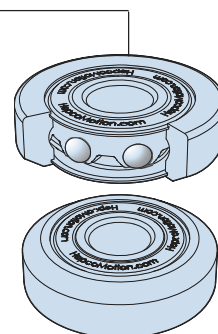
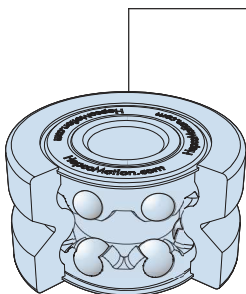

System Composition

HepcoMotion track systems combine ring segments with straight slides to achieve an almost limitless variation of open paths or closed circuits. Both left and right hand bends can be negotiated depending on the carriage selected. 90° and 180° segments in all standard double edge ring sizes are available in addition to straight slides up to 4 metres long. Straight slides can be butted together to achieve track systems of unlimited length.

Driven track system components 50-51

- Comprehensive range of drive components available from complete proven system.
- Trip latch overload protection.
- Carriage positioning and locking system.
- Toothed belt with carriage connection facility.
- Corner support plates.
- Drive and idler pulleys with Hi-load bearing cartridges.
- Support frame with slide attachment facility.

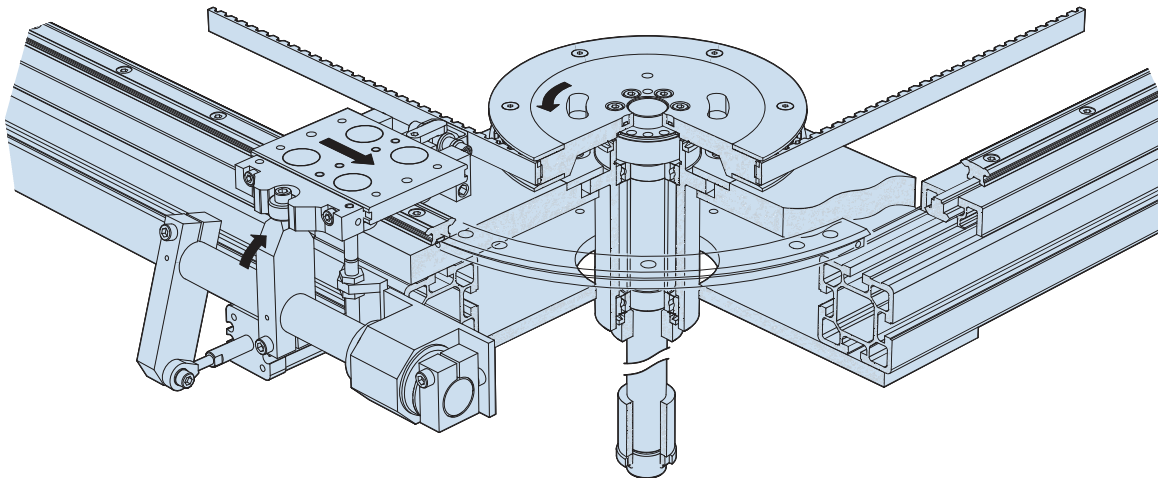

Fixed centre carriage 38-39

- The economic choice for rings and uni-directional track systems.
- Optional lubricators for increased load & life.
- Keyway facility in side faces for location of ancillary components.
- Supplied with tapped holes for ease of component mounting.
- Accurate overall height.
- Corrosion resistant version available.
- Clamping brake version for ring systems. See illustration left.
- Compatible with track system drive components and carriage locking system.

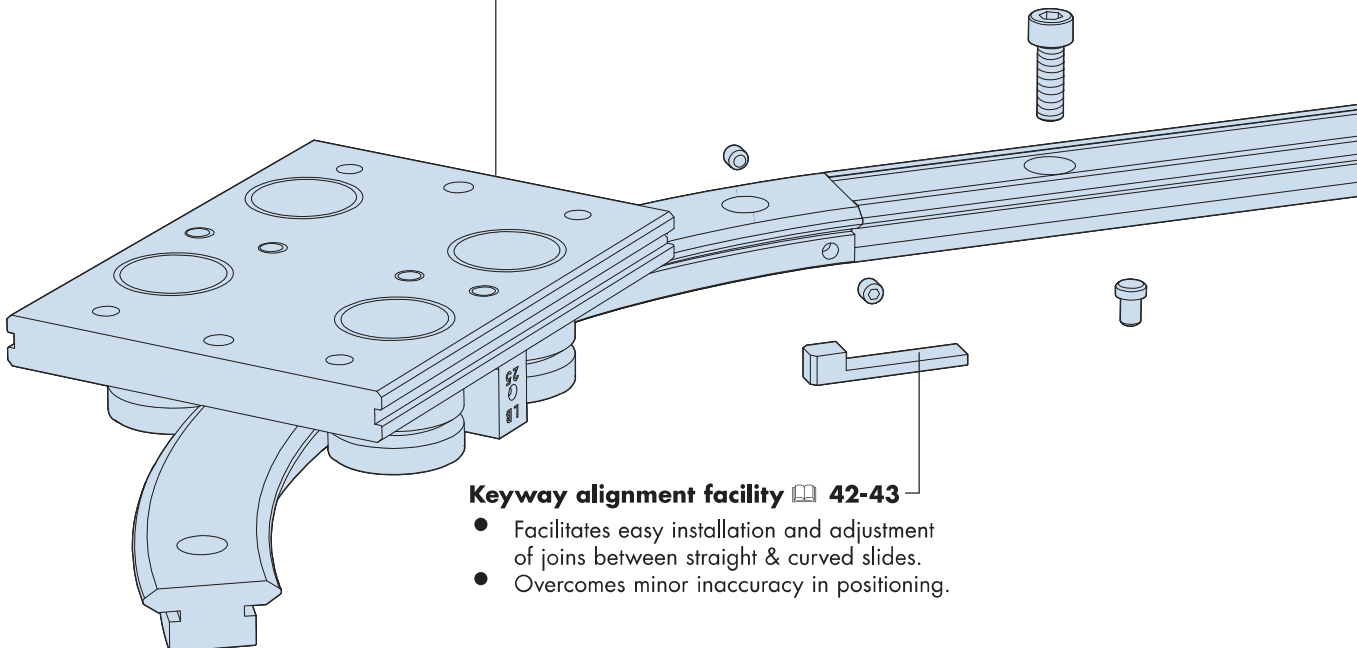
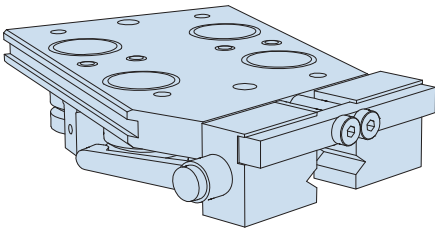

Keyway alignment facility 42-43

- Facilitates easy installation and adjustment of joins between straight & curved slides.
- Overcomes minor inaccuracy in positioning.

System Composition

● Track system straight slides 42-43 / Track system curved segments 44 *

- * Hardened V faces for maximum wear resistance.
- * Soft centre allows customising.
- * Precision ground on ends and all important faces.
- * Stainless steel option.
- * All segments and slides precision matched.
- * Ground datum faces for location purposes.
- * Option available to suit pre-drilled mounting holes.
- * 90° and 180° segments available from stock.
- * Any length segment available to order.
- Central keyway for location and alignment.
- Up to 4m in one piece, unlimited length achieved by butting.

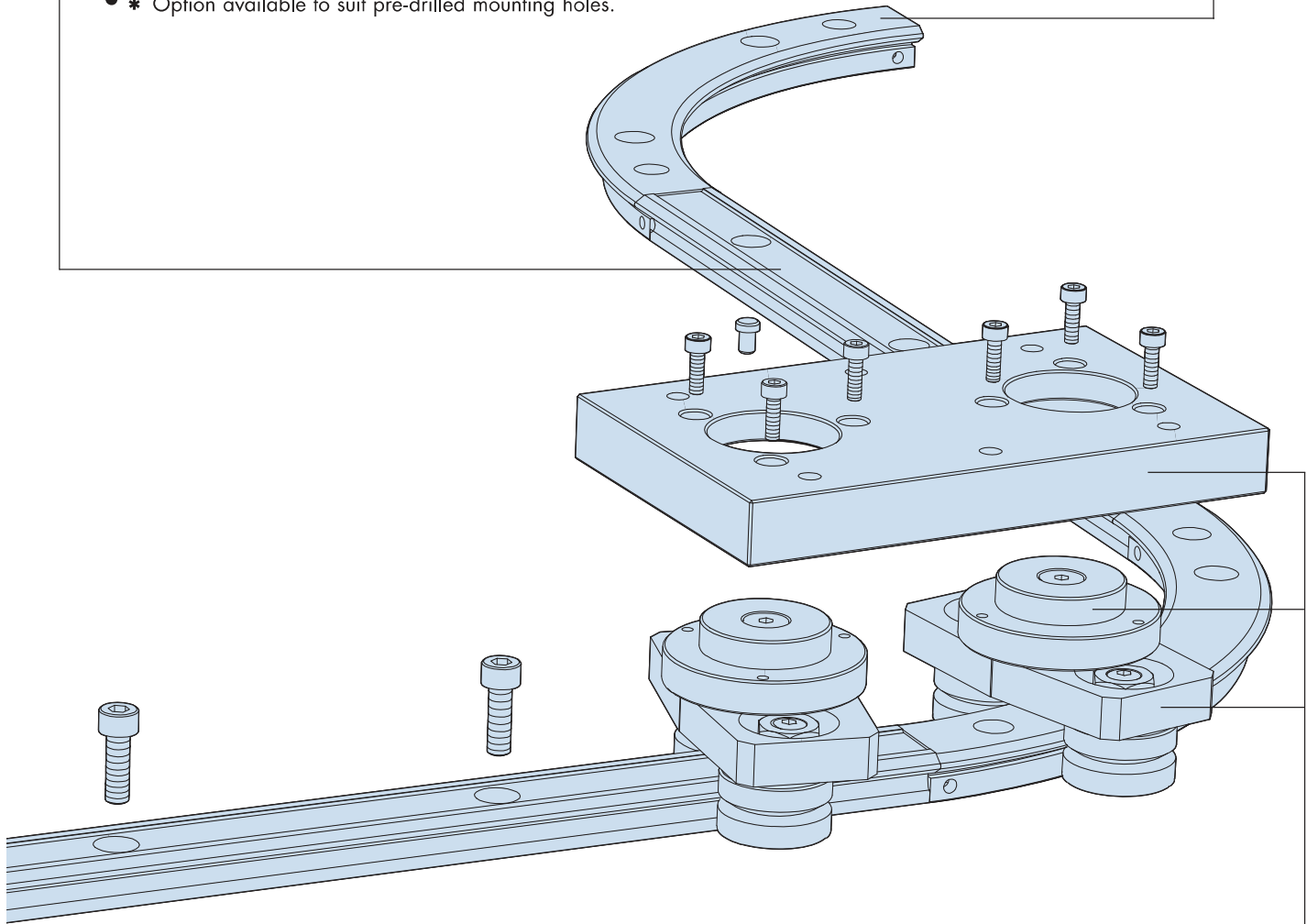

Dowel pins 42-43

- Locates in central keyway of straight slide for ease of location and alignment.

Bogie carriage 47

- Negotiates 'S' bends and differing bend radii.
- High performance swivel bearing for precision movement and extreme rigidity.
- Swivel bearings are lubricated for life internally.
- Available in three sizes to suit 25, 44 & 76 track systems.
- Supplied with tapped holes for ease of component mounting.
- Accurate overall height.
- Large platform for mounting purposes.

System Composition

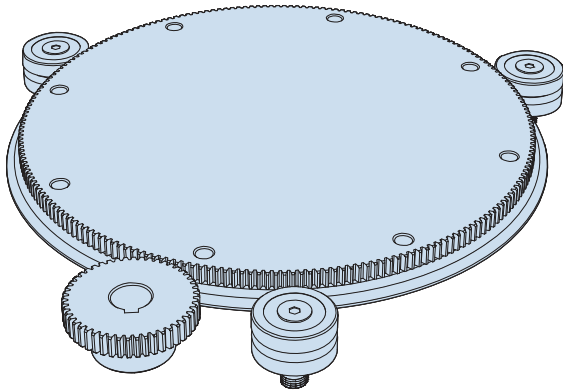

Ring Disc 32-33

- Ideally suited to turntable applications.
- Large precision mounting surface easily customised to suit customer's components.
- Precision ground all over for high accuracy and conformity.
- Gear cut option for ease of driving.
- Useful range of sizes available.
- Choice of fixing, counterbored holes or tapped hole option.
- V edge hardened for maximum wear resistance.
- Stainless steel option available.

Moment load carriage 48-49

- Supports overhanging loads and increases direct load capacity at workstations.
- Compatible with HepcoMotion carriage locking system and support frame.
- Compatible with HepcoMotion belt drive connection facility.
- Many support options possible using standard components.
- Static and dynamic support possibilities.

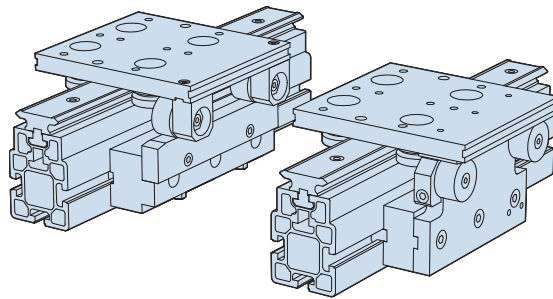

Lubricators 37

- Provides lubrication to the contact faces thereby increasing load capacity and life.
- Long lubrication interval.
- Lightly sprung felt wiper for low friction.
- Compact type suitable for through hole fixing, flanged type for through and blind hole fixing.

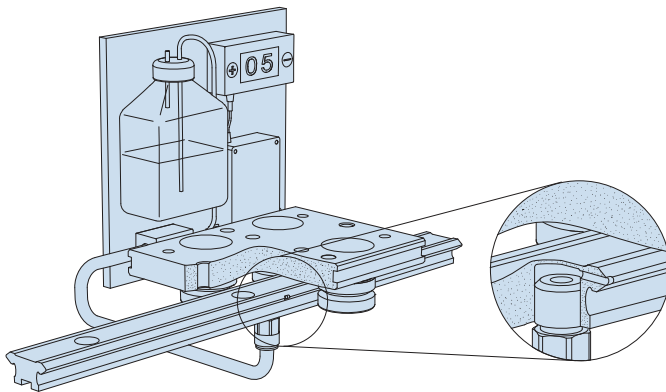
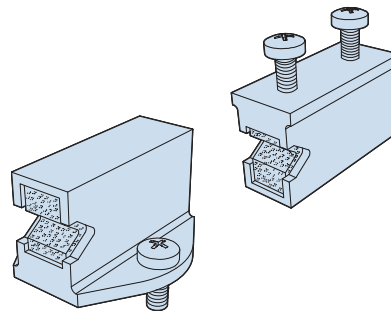

Bleed lubrication 52

- Suitable for use with track systems.
- Lubrication piped through holes, direct into the V contact faces.
- Controlled metering of lubrication.
- Overcomes necessity for lubrication service intervals

Pinions 53

- Sizes to suit all gear cut ring slides, segments and ring discs.
- Ground teeth for long life and smooth operation on sizes 1 module and above.
- Hardened teeth on larger sizes for increased durability.
- All pinions available in stainless steel as option.
- Precision machined bore, and optional keyway on sizes 1 module and above.

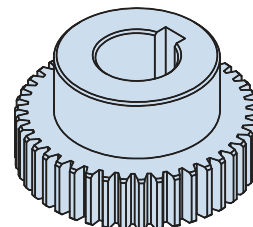

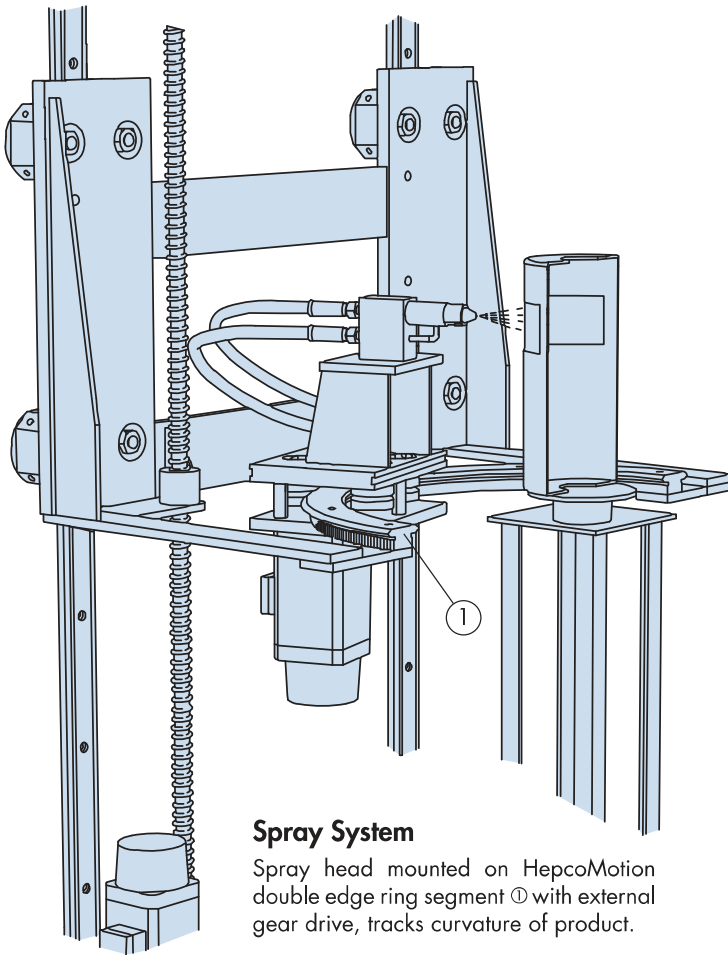

Spray System

Spray head mounted on HepcoMotion double edge ring segment ① with external gear drive, tracks curvature of product.

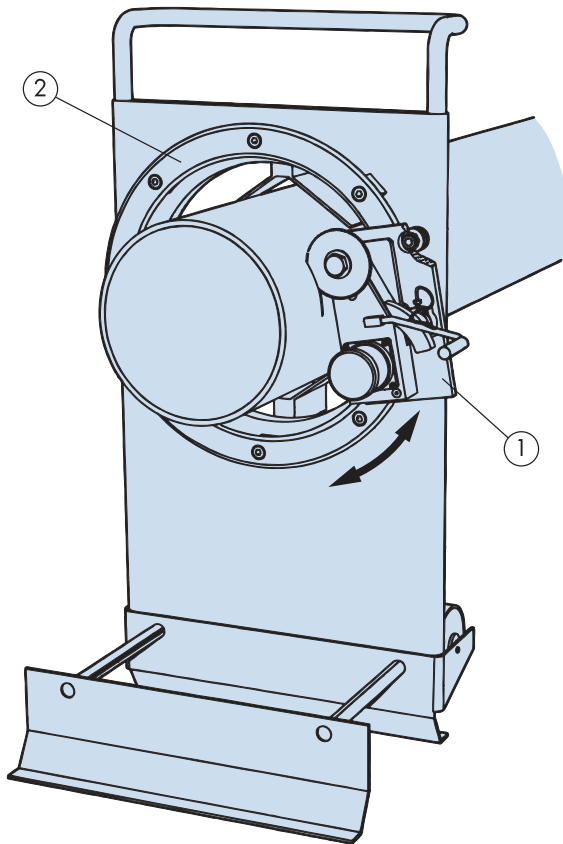

Mobile Saw for Long Tubes

Motor and saw assembly mounted on carriage ① is hand operated around 360° HepcoMotion double edge ring slide ② in order to cut tube.

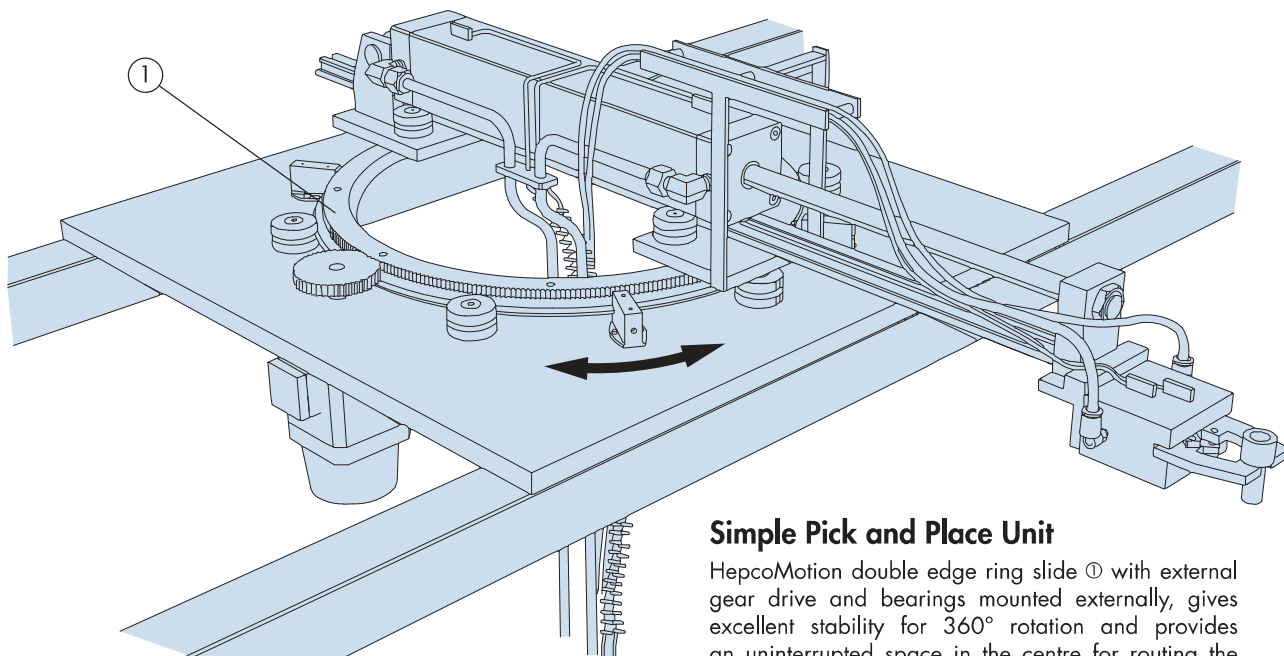

Simple Pick and Place Unit

HepcoMotion double edge ring slide ① with external gear drive and bearings mounted externally, gives excellent stability for 360° rotation and provides an uninterrupted space in the centre for routing the services.

Application Examples

Three Axis Assembly Robot

HepcoMotion ring disc with gear drive ① provides an ideal platform on which to mount the robot. The large diameter disc with HepcoMotion bearings gives support at the periphery, ensuring excellent stability and friction free motion.

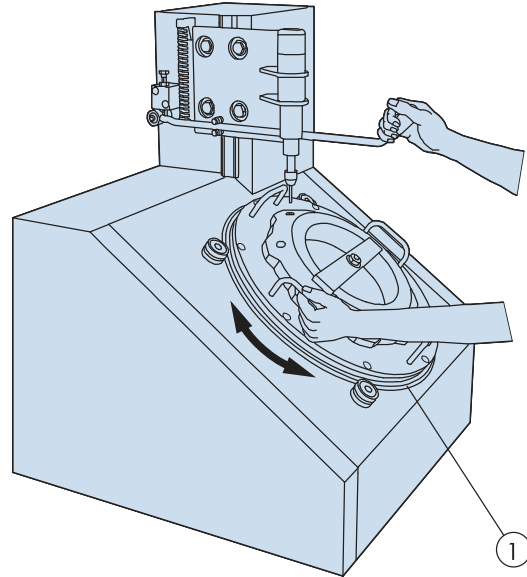
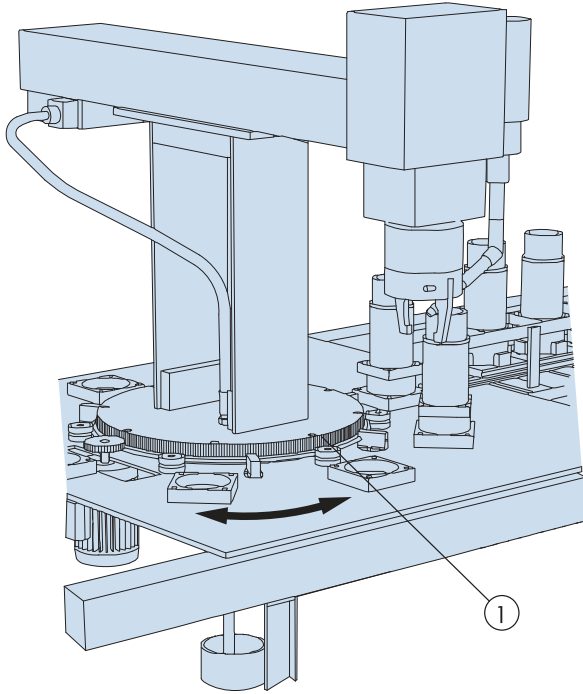

Rotary Assembly fixture

HepcoMotion ring disc ① provides a large mounting area for attaching components. The precision ground surface ensures accuracy and the unhardened area inboard of the V's enables tooling holes to be drilled as required.

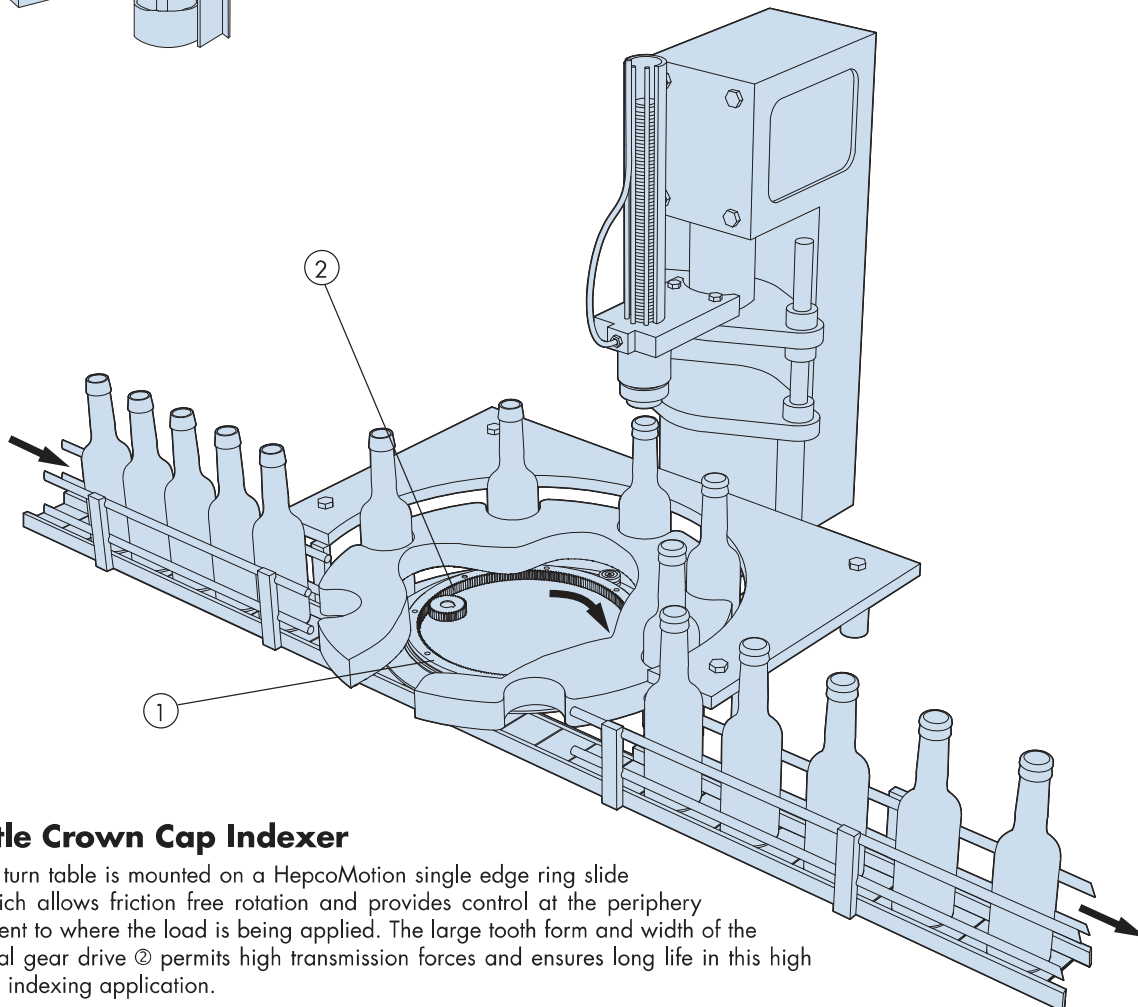

Bottle Crown Cap Indexer

Bottle turn table is mounted on a HepcoMotion single edge ring slide ① which allows friction free rotation and provides control at the periphery adjacent to where the load is being applied. The large tooth form and width of the internal gear drive ② permits high transmission forces and ensures long life in this high speed indexing application.

Application Examples

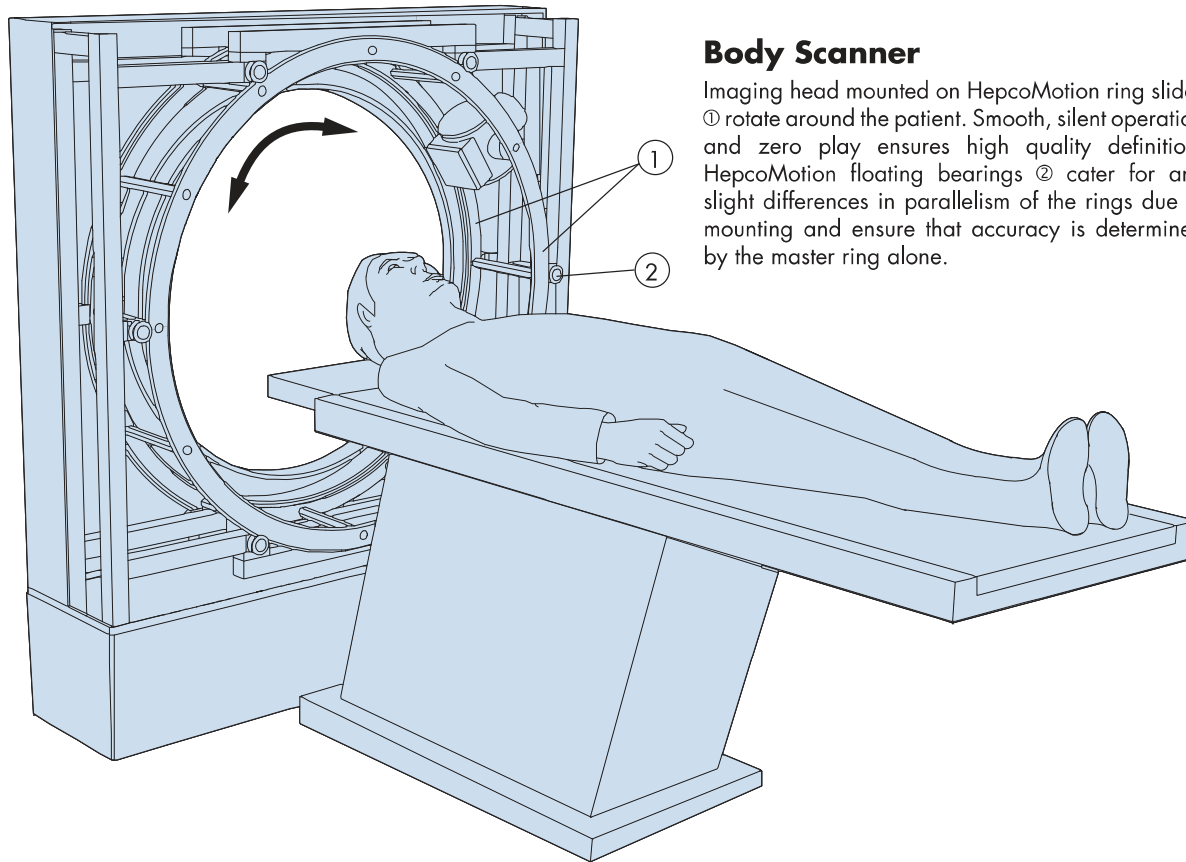

Body Scanner

Imaging head mounted on HepcoMotion ring slides ① rotate around the patient. Smooth, silent operation and zero play ensures high quality definition. HepcoMotion floating bearings ② cater for any slight differences in parallelism of the rings due to mounting and ensure that accuracy is determined by the master ring alone.

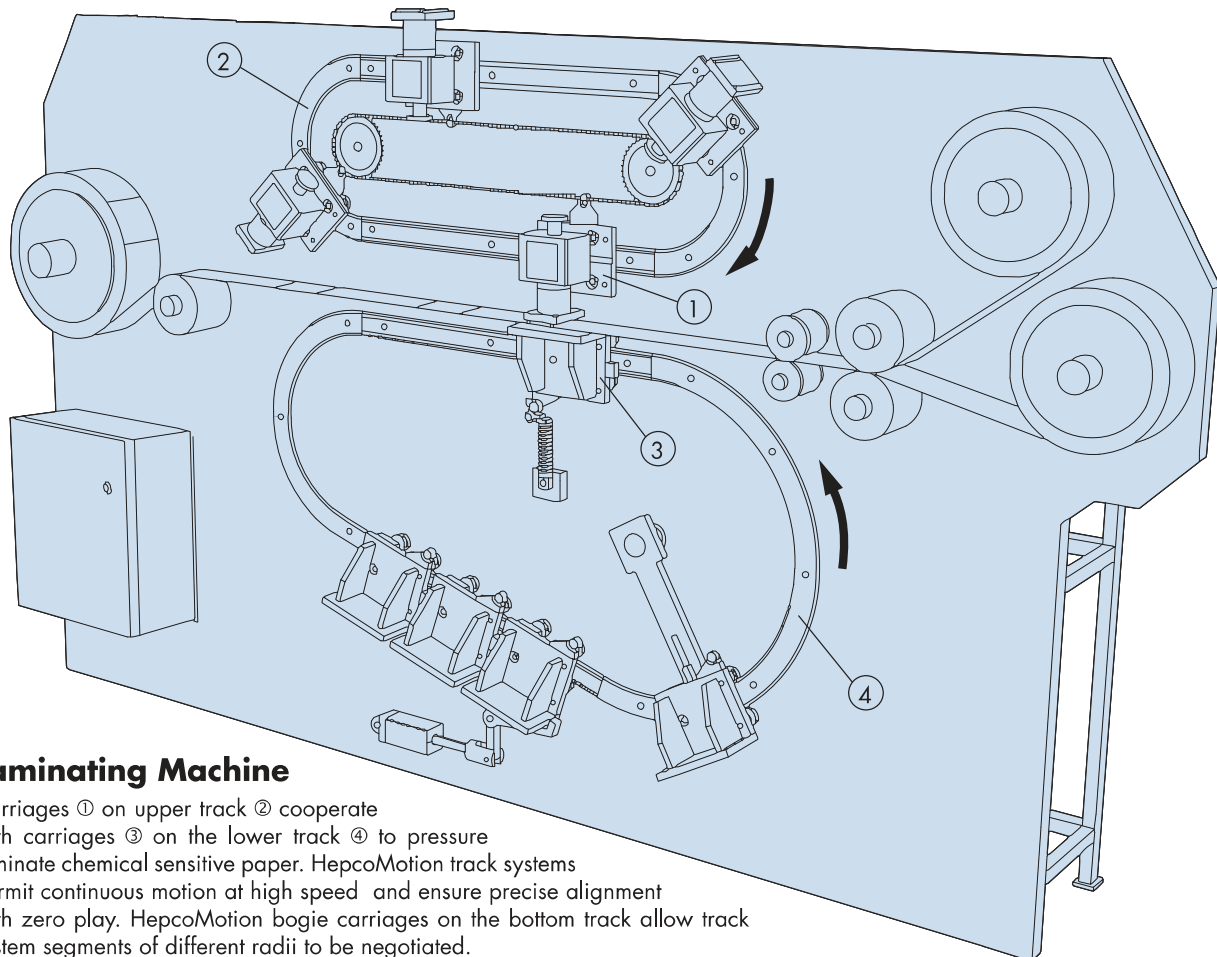

Laminating Machine

Carriages ① on upper track ② cooperate with carriages ③ on the lower track ④ to pressure laminate chemical sensitive paper. HepcoMotion track systems permit continuous motion at high speed and ensure precise alignment with zero play. HepcoMotion bogie carriages on the bottom track allow track system segments of different radii to be negotiated.

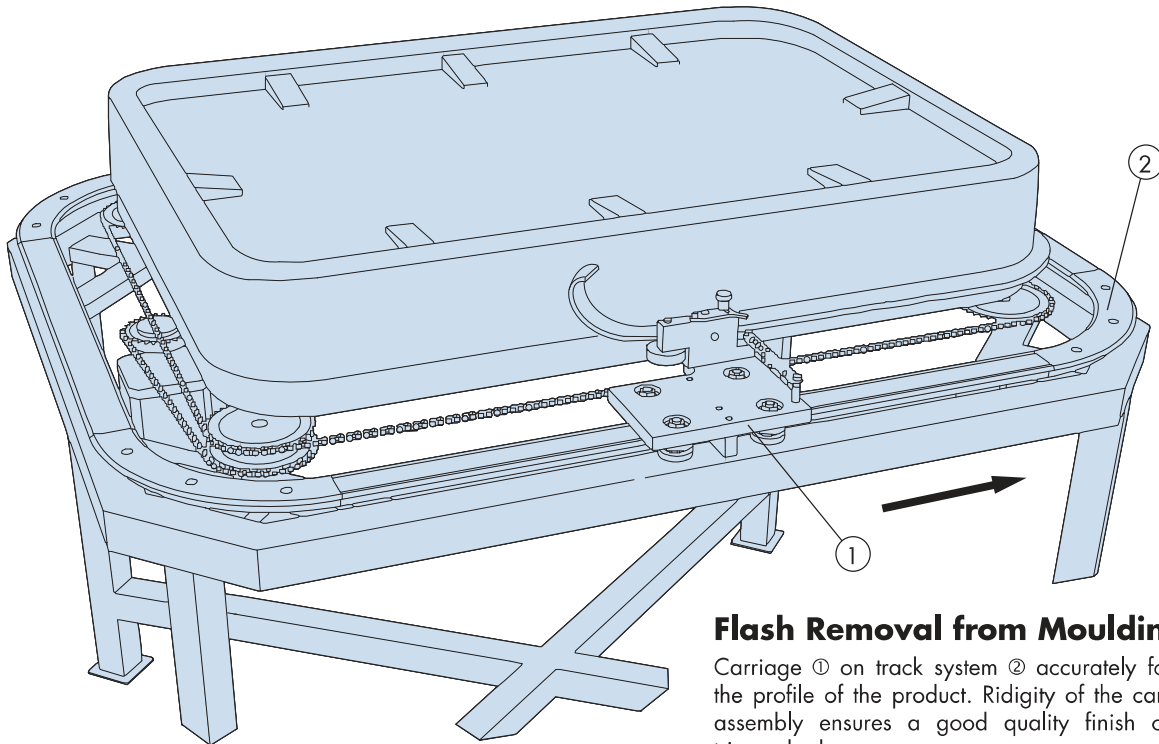

Flash Removal from Moulding

Carriage ① on track system ② accurately follows the profile of the product. Rigidity of the carriage assembly ensures a good quality finish of the trimmed edge.

Multi-Station Assembly Machine

Carriages linked by connecting rods ① are indexed around a track system circuit ② by means of a walking beam system operated by HepcoMotion GV3 straight slides ③. Zero play and precise positioning enables highly accurate work to take place at each station. Bogie carriages ④ provide a large platform for mounting the components.

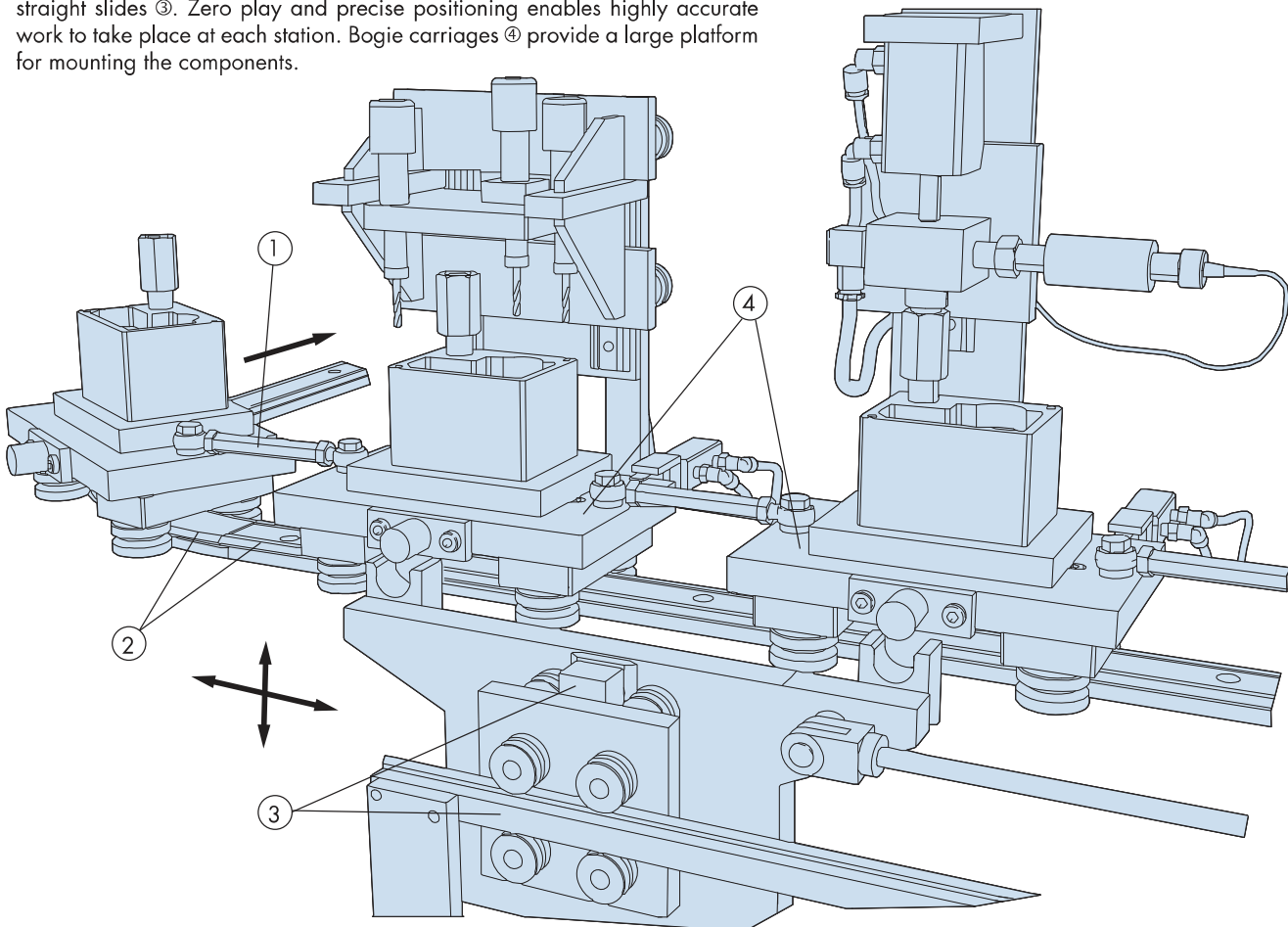

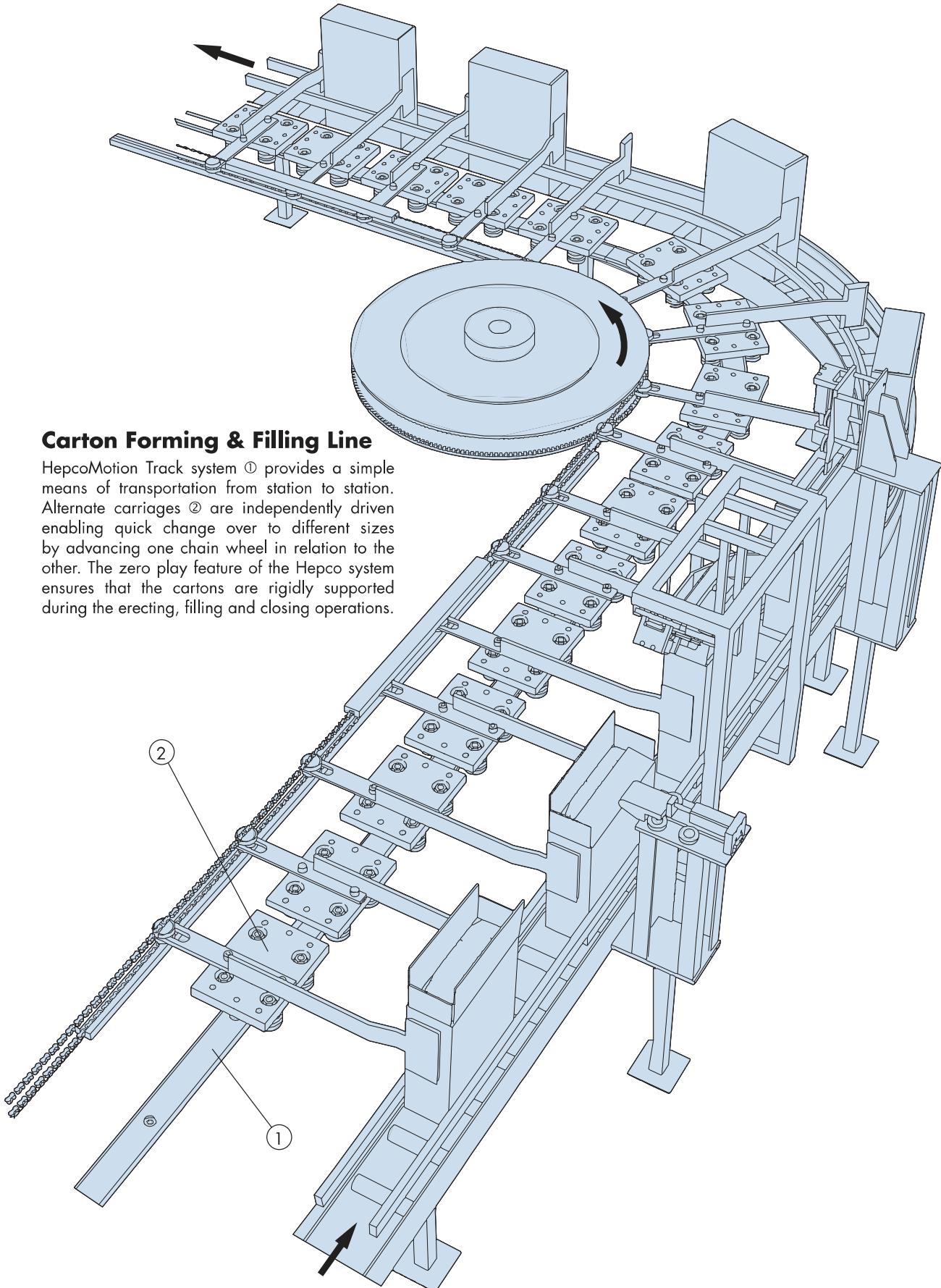

Carton Forming & Filling Line

HepcoMotion Track system ① provides a simple means of transportation from station to station. Alternate carriages ② are independently driven enabling quick change over to different sizes by advancing one chain wheel in relation to the other. The zero play feature of the Hepco system ensures that the cartons are rigidly supported during the erecting, filling and closing operations.

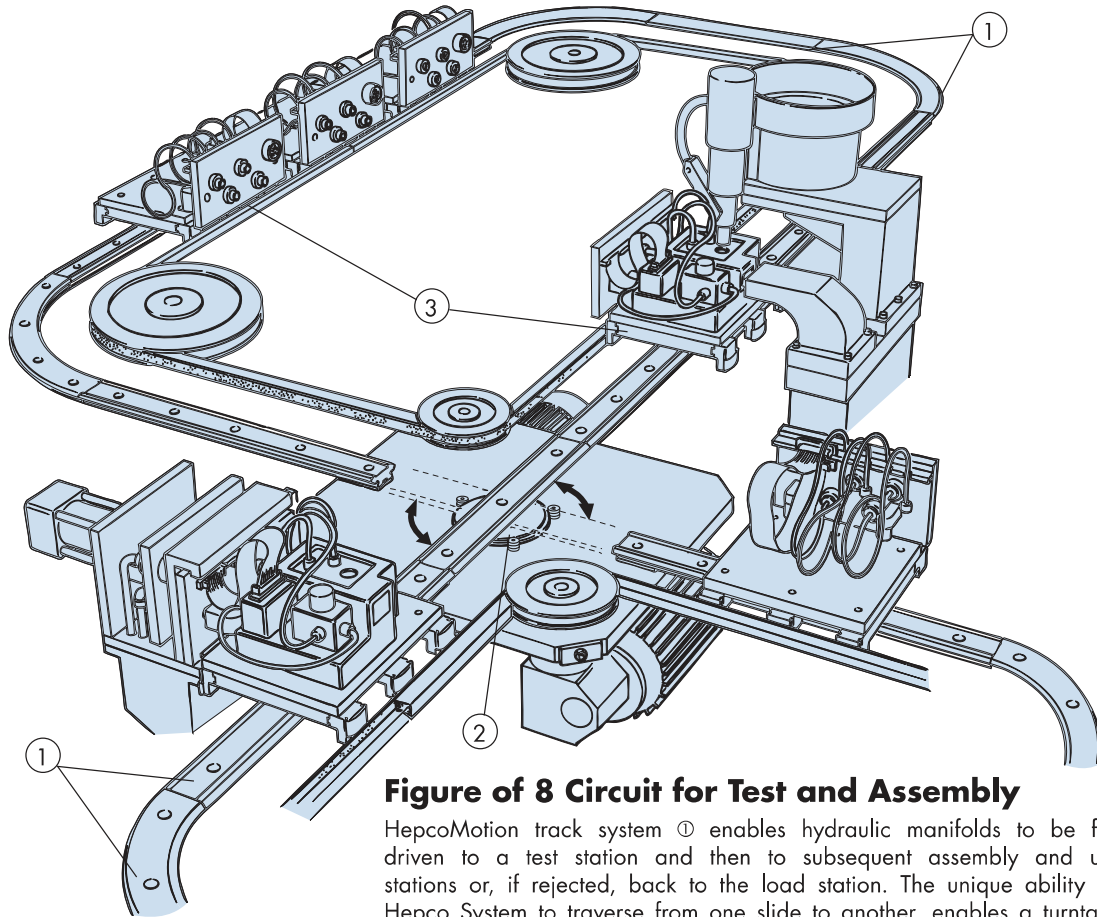

Figure of 8 Circuit for Test and Assembly

HepcoMotion track system ① enables hydraulic manifolds to be friction driven to a test station and then to subsequent assembly and unload stations or, if rejected, back to the load station. The unique ability of the Hepco System to traverse from one slide to another, enables a turntable to be designed at the crossover junction using a HepcoMotion ring disc ② to provide rotary movement. Bogie carriages ③ allow S bends to be traversed.

Optical Lens Assembly

Machine incorporates a standard HepcoMotion DTS complete driven track system for which there is a separate catalogue. See also 50 & 51.

Lenses are loaded by pick and place units onto clamp fixtures mounted on HepcoMotion carriages ①. Optical adhesive is applied between lenses before passing through ultra-violet light box to activate hardener. Precise positioning of carriages is required at work stations, this is achieved by means of the HepcoMotion carriage locking system ②.

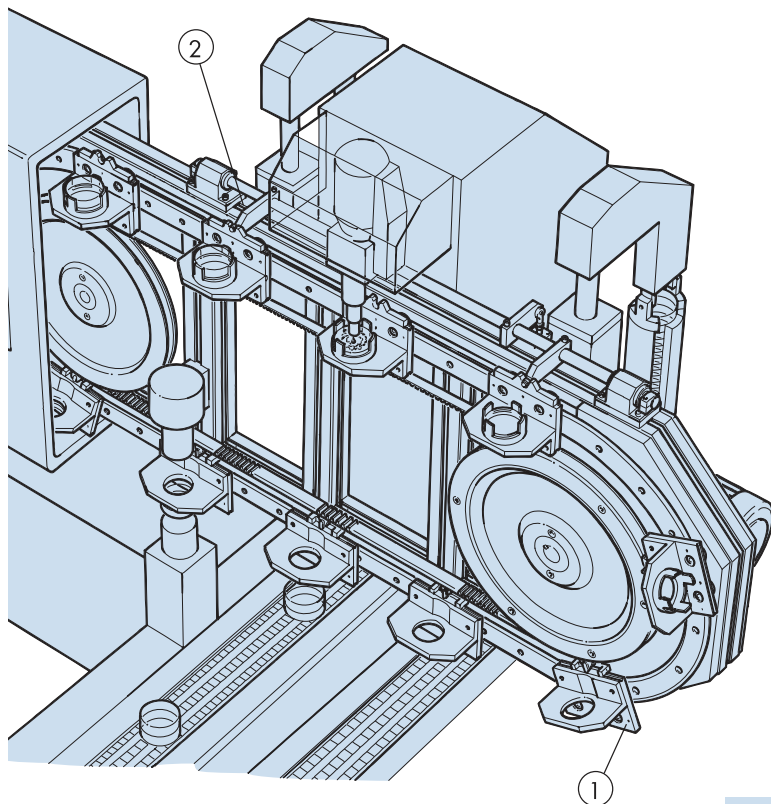

Clamping Method for Belt to Carriage Connection

Carriages are connected to the belt by means of clamping device ①, resulting in a strong fixing which overcomes the need to screw through the belt. The pulleys must be machined to provide recesses ② in order to accommodate the clamps. The slip block method 19 should be used to adjust track system length in relation to the tensioned belt.

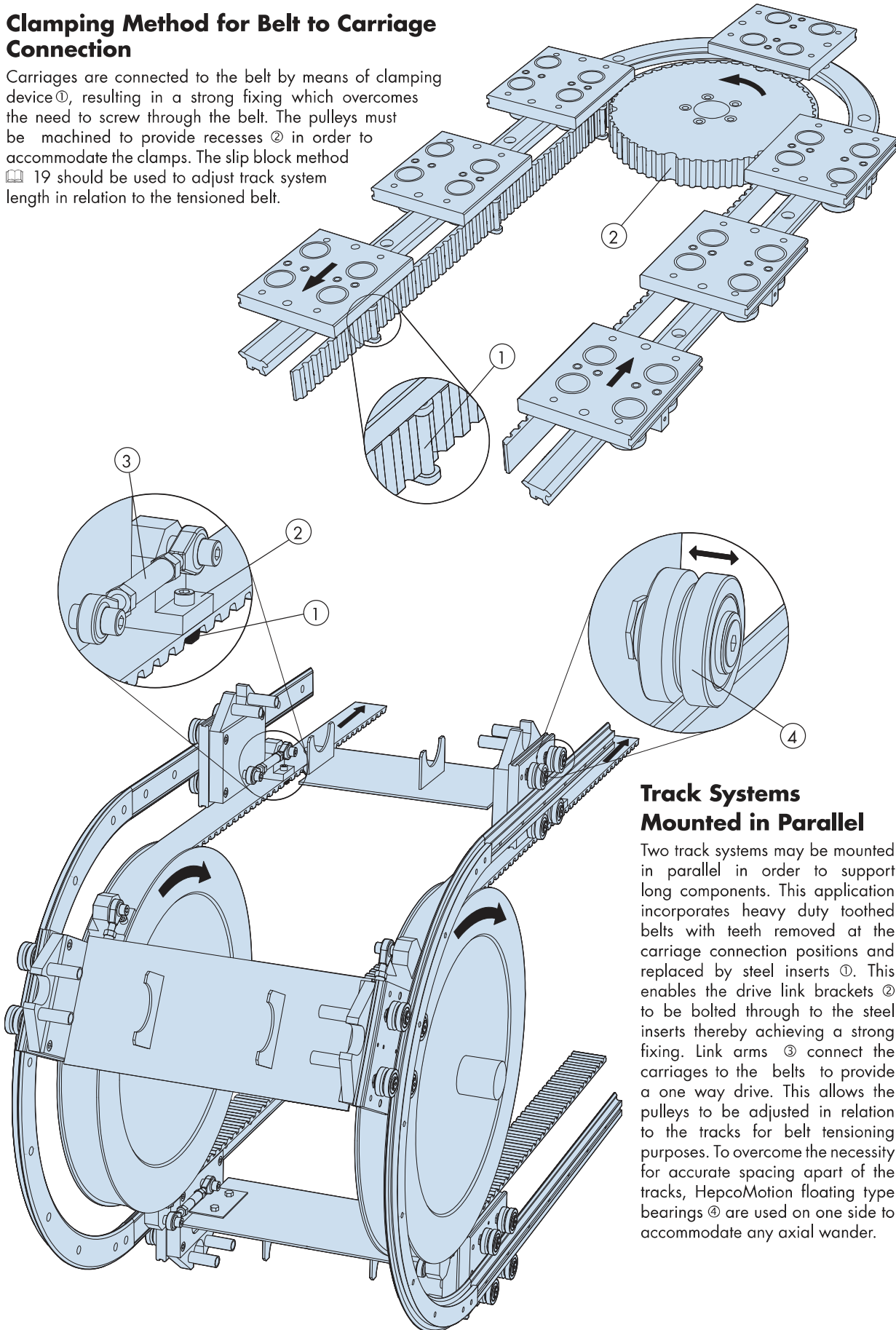

Track Systems Mounted in Parallel

Two track systems may be mounted in parallel in order to support long components. This application incorporates heavy duty toothed belts with teeth removed at the carriage connection positions and replaced by steel inserts ①. This enables the drive link brackets ② to be bolted through to the steel inserts thereby achieving a strong fixing. Link arms ③ connect the carriages to the belts to provide a one way drive. This allows the pulleys to be adjusted in relation to the tracks for belt tensioning purposes. To overcome the necessity for accurate spacing apart of the tracks, HepcoMotion floating type bearings ④ are used on one side to accommodate any axial wander.

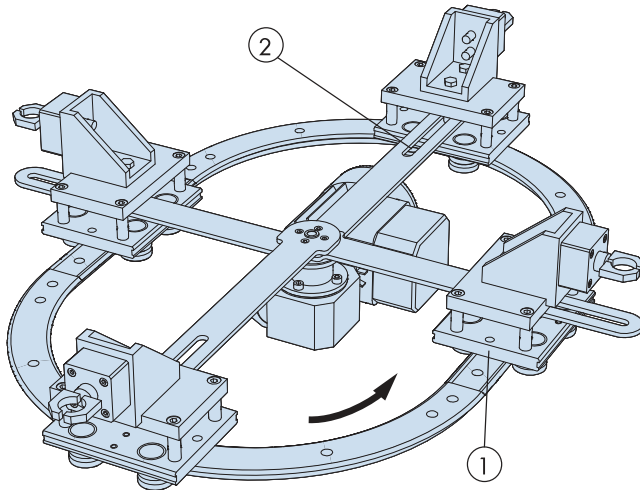

Spider Drive

For short track systems carriages ① can be driven from a central motor and spider. The arms of the spider ② incorporate slots to accommodate the changing distance of the carriages from the motor drive shaft.

Pocket Wheel Drive

Carriages are linked together by connecting rods ①. A cam follower ② located on each carriage engages with cutouts ③ in a pocket drive wheel which moves the carriage around the track system. This method of driving requires some compliance in the connecting rods and sufficient clearance in the wheel for cam follower engagement.

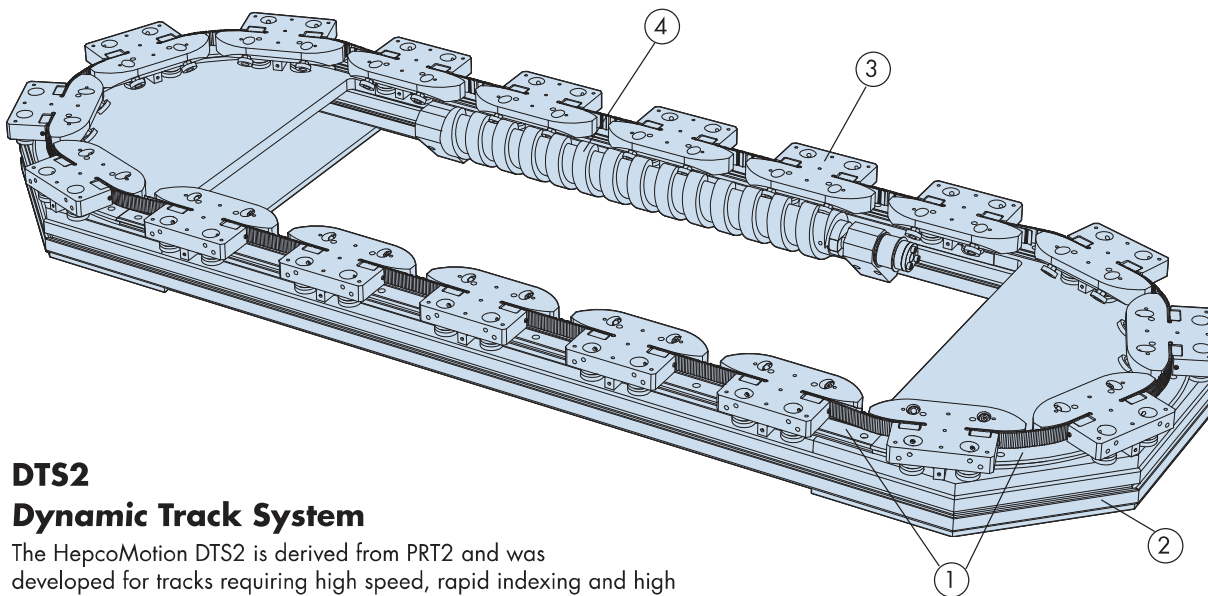
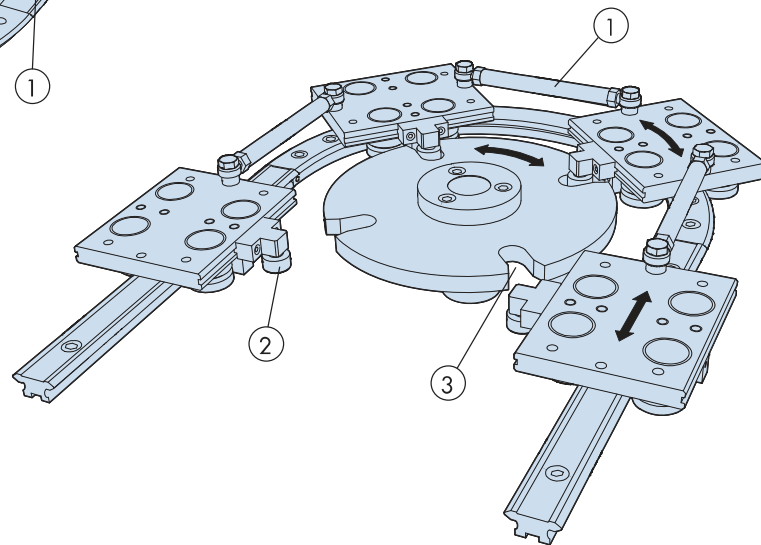

DTS2 Dynamic Track System

The HepcoMotion DTS2 is derived from PRT2 and was developed for tracks requiring high speed, rapid indexing and high driving forces. It includes a PRT2 track ①, mounted on a Hepco MCS compatible frame ②. Its carriages ③, are linked with adjustable spring-loaded belts and driven by a screw ④. The DTS2 can be supplied with motors, drives and bleed lubrication system (52).

DTS2 units can be oval as illustrated, rectangular, or have any other valid track layout without S-bends. A range of sizes is available, in either standard or corrosion resistant version.

A datasheet for DTS2 is included at www.HepcoMotion.com/dts2datauk.

Slotted Carriage Connection For Belt Adjustment

The timing belt is fitted with U section attachments ① secured to the belt with countersunk screws. Pins ② engage with slotted drive member ③ which drives the carriage around the circuit. In this type of design whether using a belt or chain, it is important to provide a slot to allow for tension adjustment and also to cater for slight variation in the proximity of carriage to belt or chain, as the carriage traverses from straight to curve.

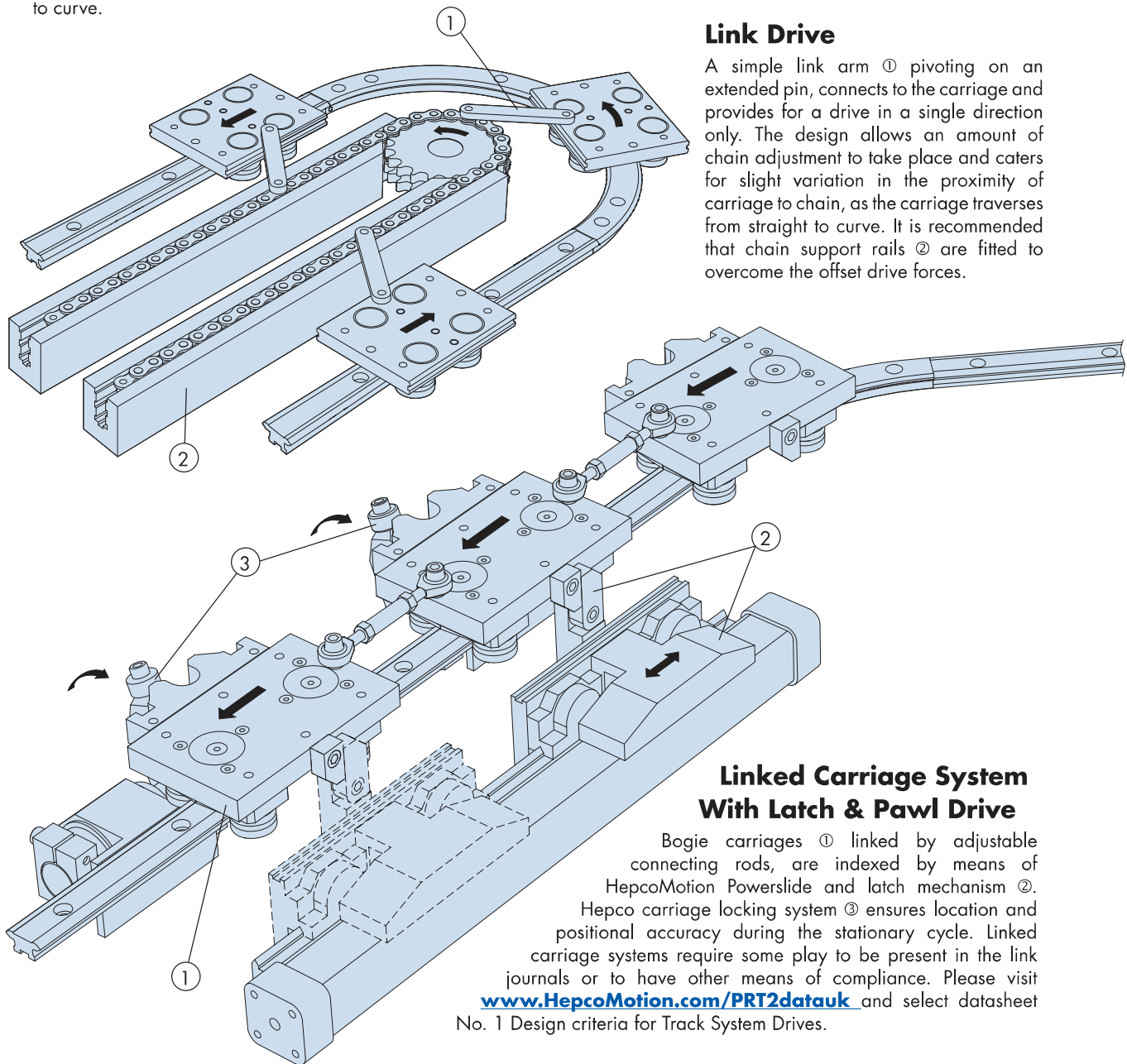
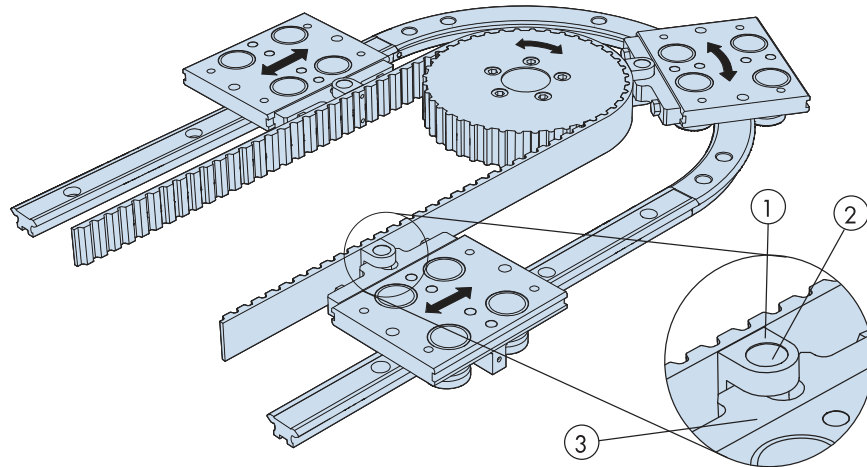

Link Drive

A simple link arm ① pivoting on an extended pin, connects to the carriage and provides for a drive in a single direction only. The design allows an amount of chain adjustment to take place and caters for slight variation in the proximity of carriage to chain, as the carriage traverses from straight to curve. It is recommended that chain support rails ② are fitted to overcome the offset drive forces.

Linked Carriage System With Latch & Pawl Drive

Bogie carriages ① linked by adjustable connecting rods, are indexed by means of HepcoMotion Powerslide and latch mechanism ②. Hepco carriage locking system ③ ensures location and positional accuracy during the stationary cycle. Linked carriage systems require some play in the link journals or to have other means of compliance. Please visit www.HepcoMotion.com/PRT2datauk and select datasheet No. 1 Design criteria for Track System Drives.

Linked Carriage System With Scroll Drive

Bogie carriages ① linked by adjustable connecting rods, incorporate rollers ② which engage with the screw ③ to provide either intermittent or continuous motion drive. Linked carriage systems require some play to be present in the link journals or to have other means of compliance. Please visit www.HepcoMotion.com/PRT2datauk and select datasheet No. Design criteria for Track System Drives.

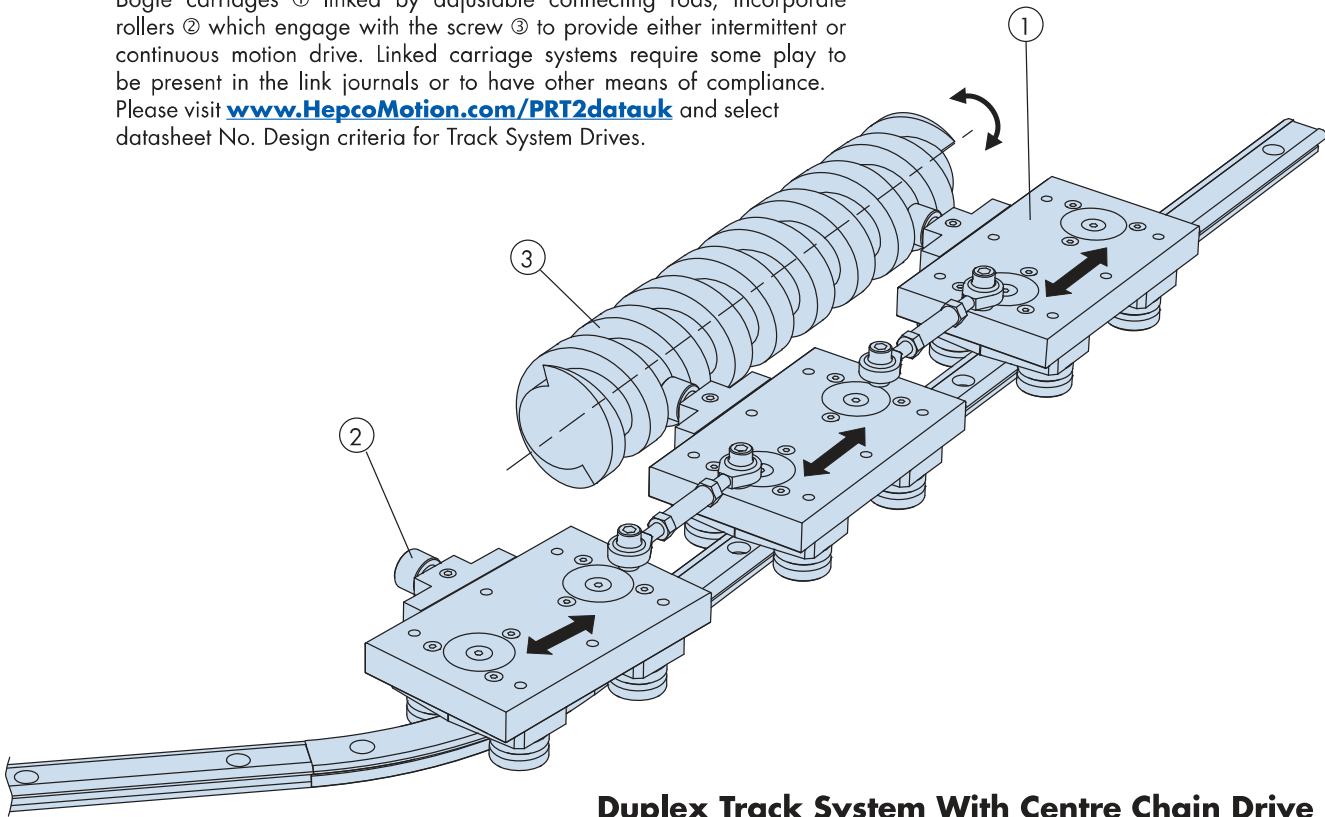

Duplex Track System With Centre Chain Drive

This durable and highly stable duplex track system capable of withstanding high loads, is available complete with special chain and scroll drive system from Hepco. The track system comprises of duplex single edge slides ① and a central drive to ensure constant velocity around the circuit. Any number of carriages at virtually any spacing can be accommodated on the system which can be supplied complete with motor and mounted on a Hepco MCS frame. Chain adjustment is rarely required but is achieved by the slip block method ② as shown and further illustrated 19. Either intermittent or constant motion is possible in either direction. A unique mechanism within the carriage in conjunction with the carriage locking system ③ 150-51, enables index positioning to within 0.02mm to be achieved.

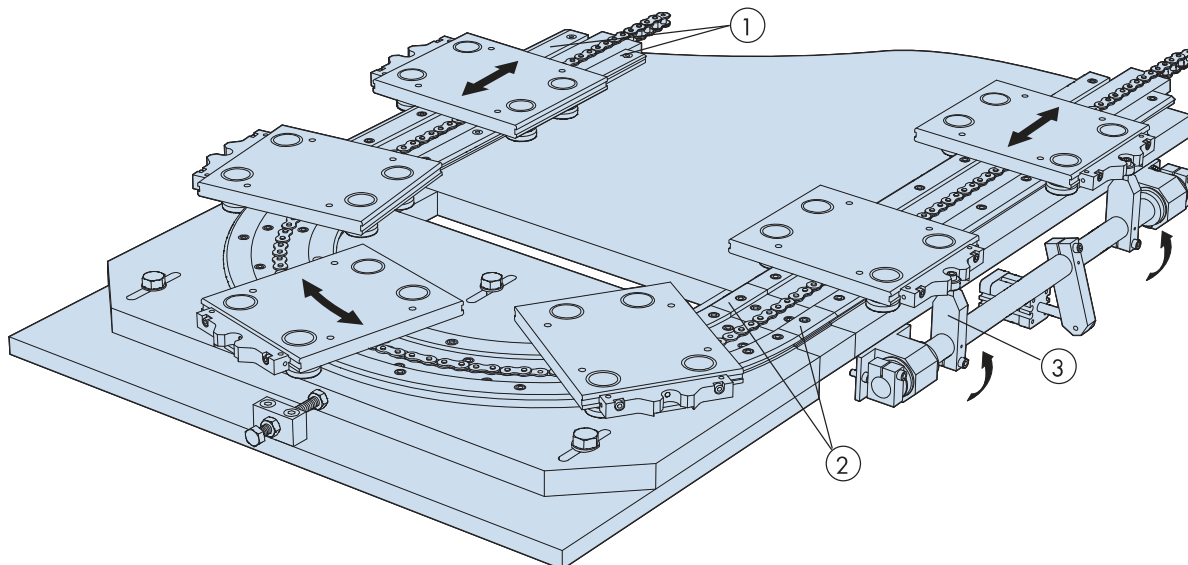

Application Examples

Gear Driven Duplex Track System

Single edge track system with a gear drive on the inner curved and straight slides ①, engages with pinion ② driven from the motor. A sprung pivot arm ③ ensures that the pinion remains engaged with the rack as it travels from straight to curve. The system is a standard HepcoMotion design and can be supplied either in part or, as a complete system with motor as required.

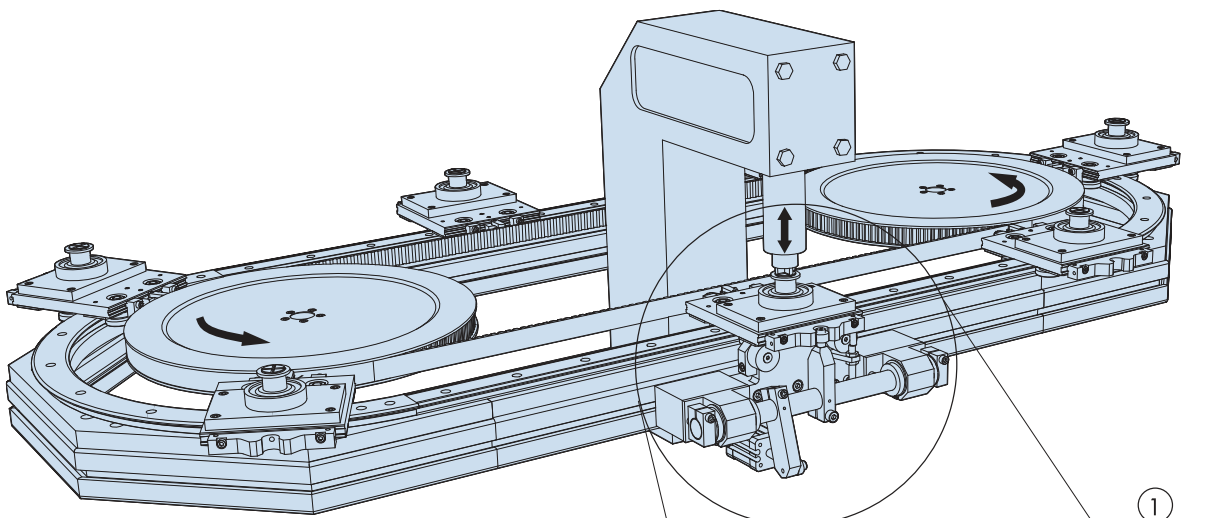
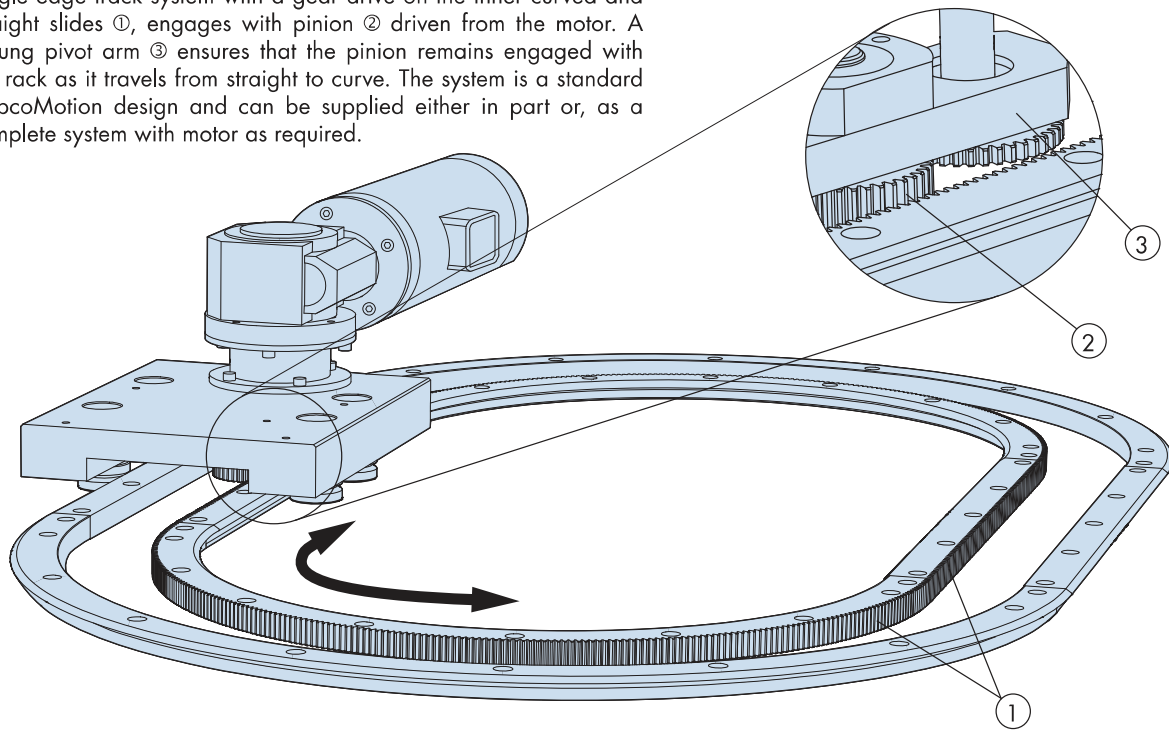

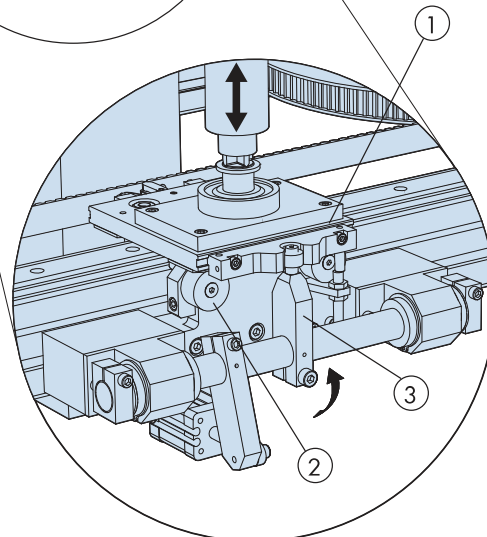

Track System With Moment Load Carriage

In this standard HepcoMotion Driven Track System example a high downwards force is being applied to the carriage during a stamping operation. The moment load carriage ① and static roller support ② provides additional support whilst the force is being applied. A HepcoMotion carriage locking system ③ 50-51 ensures precise location and positional accuracy whilst the operation takes place.



Chain Tensioning for Long Track Systems

A track system driven by a chain or belt ideally requires a means of adjustment for pretensioning and to allow for subsequent wear and stretch, particularly in the case of a chain drive. Limited adjustment can be achieved by providing a slot at the chain to carriage connection point (see top illustration  16) or by link connection of chain to carriage (see centre illustration  16 and example below). However, in systems where a large amount of adjustment is anticipated or where the path of the belt or chain must follow in exact relationship to the path of the track, the Slip Block or Bridging methods of adjustment should be considered.

Slip Block Adjustment Method

Hepco can provide sets of short length straight slides in various increments of length, precisely matched to those on the track system and with square ground ends. Each slide will be marked according to its length. Slide support blocks can also be supplied to customer's drawing if required. Please visit www.HepcoMotion.com/PRT2datauk and select datasheet No.10 Slip Block adjustment method.

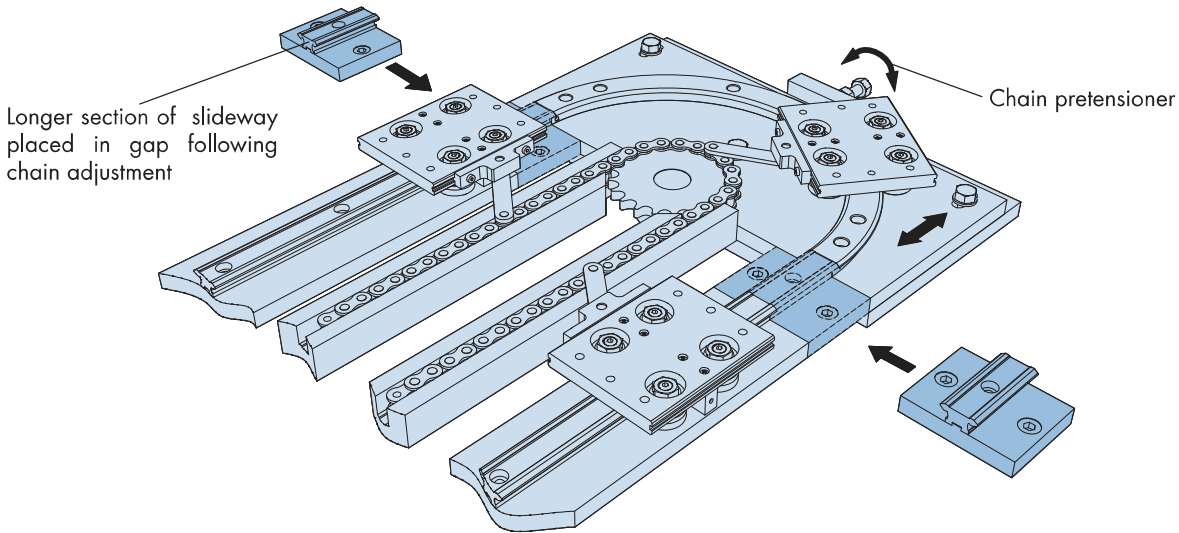



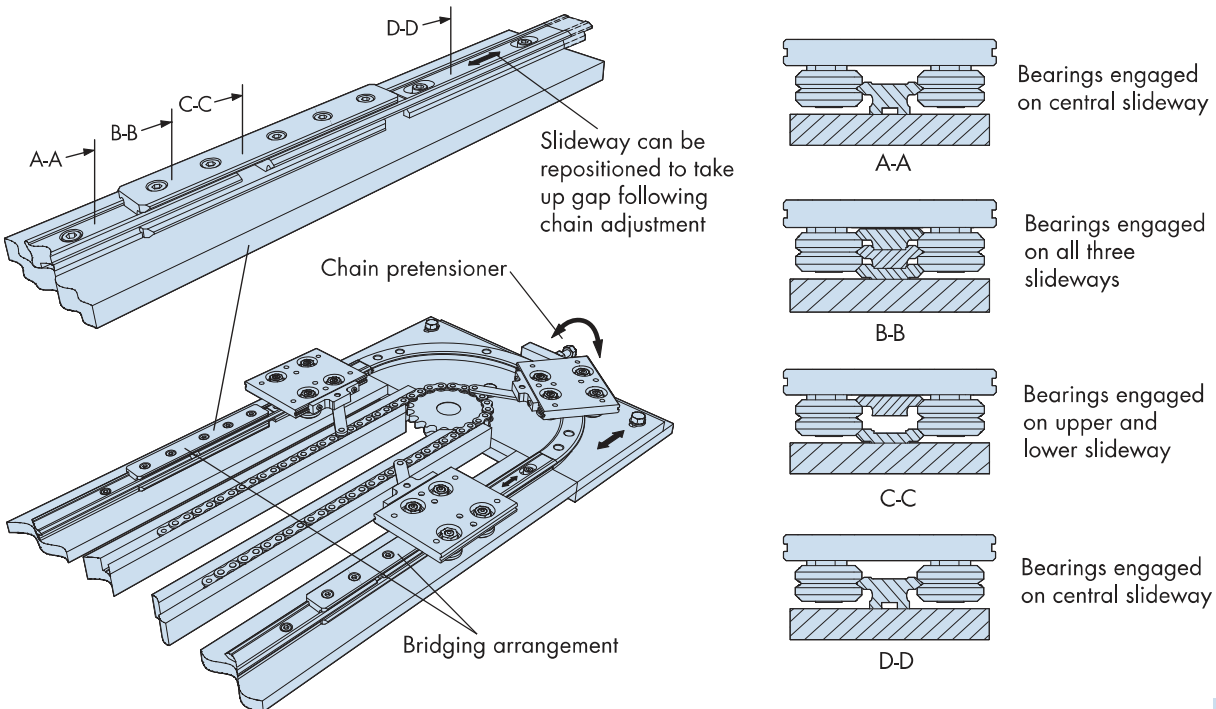

Bridging Slide Adjustment Method

The bridging slide arrangement enables the track to be extended following adjustment of the chain drive whilst maintaining continuity of guidance and control. In order to traverse the adjustment gap, the bearings have external chamfers on the outside diameter in addition to the normal central V. The bridging slide arrangement comprises of three fixed slideways and one adjustable slideway, see illustrations below. All components comprising the bridging slide arrangement and special bearings can be readily supplied. Please advise total amount of slide adjustment required.

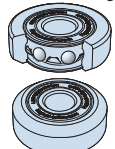
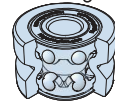

Full Size Illustrations For Initial Selection

Full size illustrations of the basic range of Ring slide systems together with a comparison table for bearings and lubrication are provided to help with initial selection. Customers should refer to the individual component pages for dimensions and to the Technical section for details of load and life. There is a wide range of other options and components complementary to those shown in this section. These are illustrated in the System Composition  2-7 and throughout the catalogue.

Bearing	Load				Speed	Smoothness	Tolerance of Misalignment		Ridgity		Tolerance of Debris		Price	
														
	☹	☺	☹	☺			☹	☺	☹	☺	☹	☺	☹	☺
Twin Bearing 	■	■	■	■	■	■	■	■	■	■	■	■	■	■
Double Row Bearing 	■	■	■	■	■	■	■	■	■	■	■	■	■	■
Floating Bearing 		■	■	■	■	■	■	■	■	■	■	■	■	■

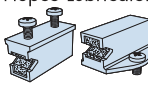
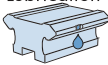
Lubrication Method	Load		Lubrication interval		Friction		Life		Price	
	☹	☺	☹	☺	☹	☺	☹	☺	☹	☺
None	■				■		■		■	
Hepco Lubricator 	■	■	■	■	■		■		■	
Hepco Bleed Lubrication 	■	■	Automatic lube frequency possible		■		■		■	

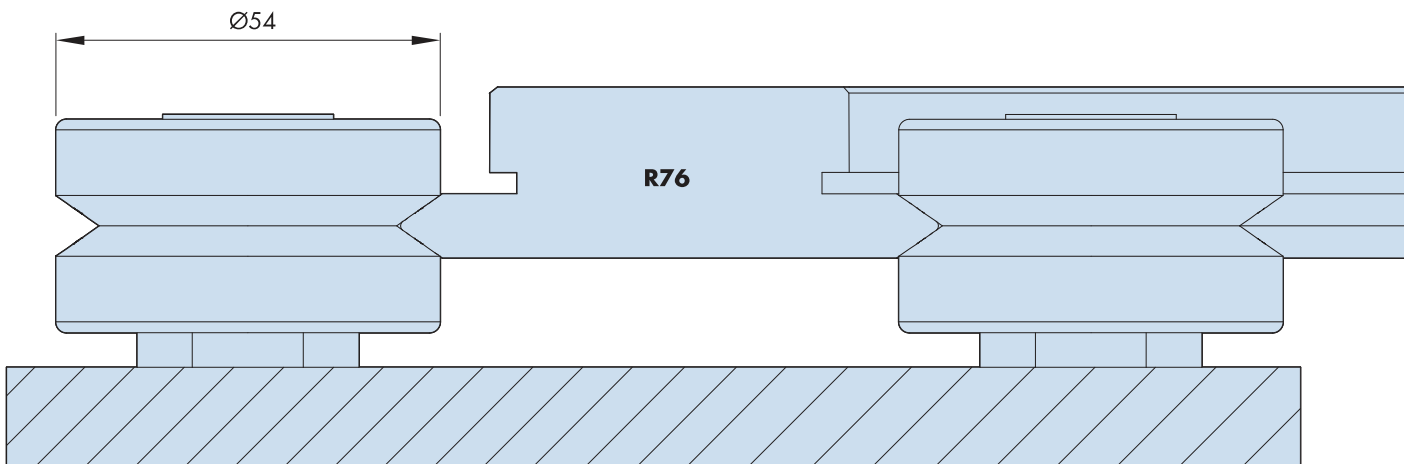

Full Size Illustrations For Initial Selection

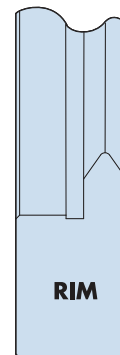
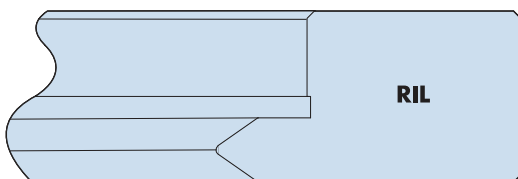
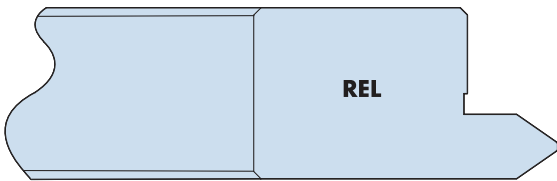
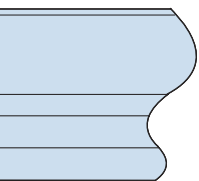
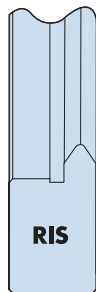
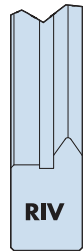
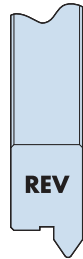
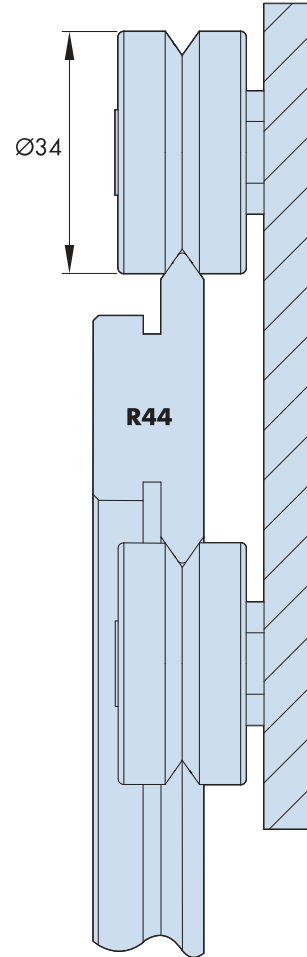
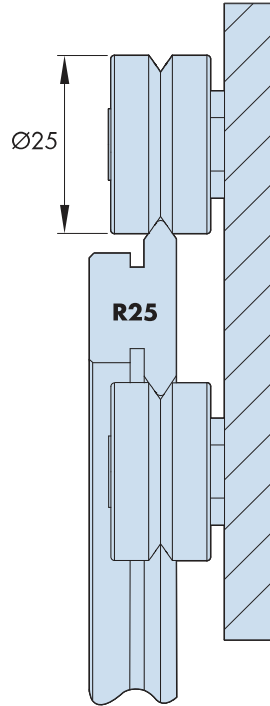
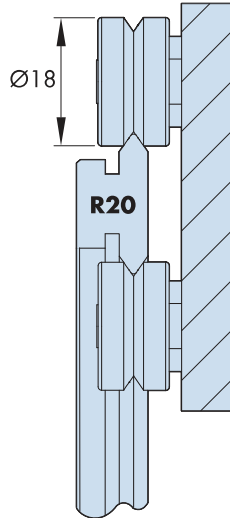
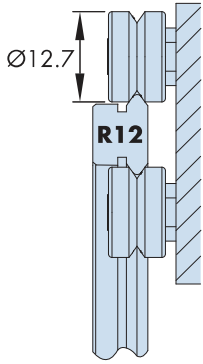

Assembled Systems
22-25

Ring slides
26-33

Bearings
34-36

Lubricators
37

Bleed Lubrication
52

XYZ
ABC
123
Calculations
54-57

Assembled Double Edge Ring System

The HepcoMotion double edge ring system with carriage may be used in either complete ring form or with segments. It can also be combined with straight slides to form a track system [40-44](#).

Rings may also be encircled by bearings either externally and/or internally with either ring or bearings being the moving element (see page opposite). The HepcoMotion PRT2 eccentric bearings are of double eccentric design with sufficient throw to enable disengagement of the carriage or encircled ring, without further disassembly.

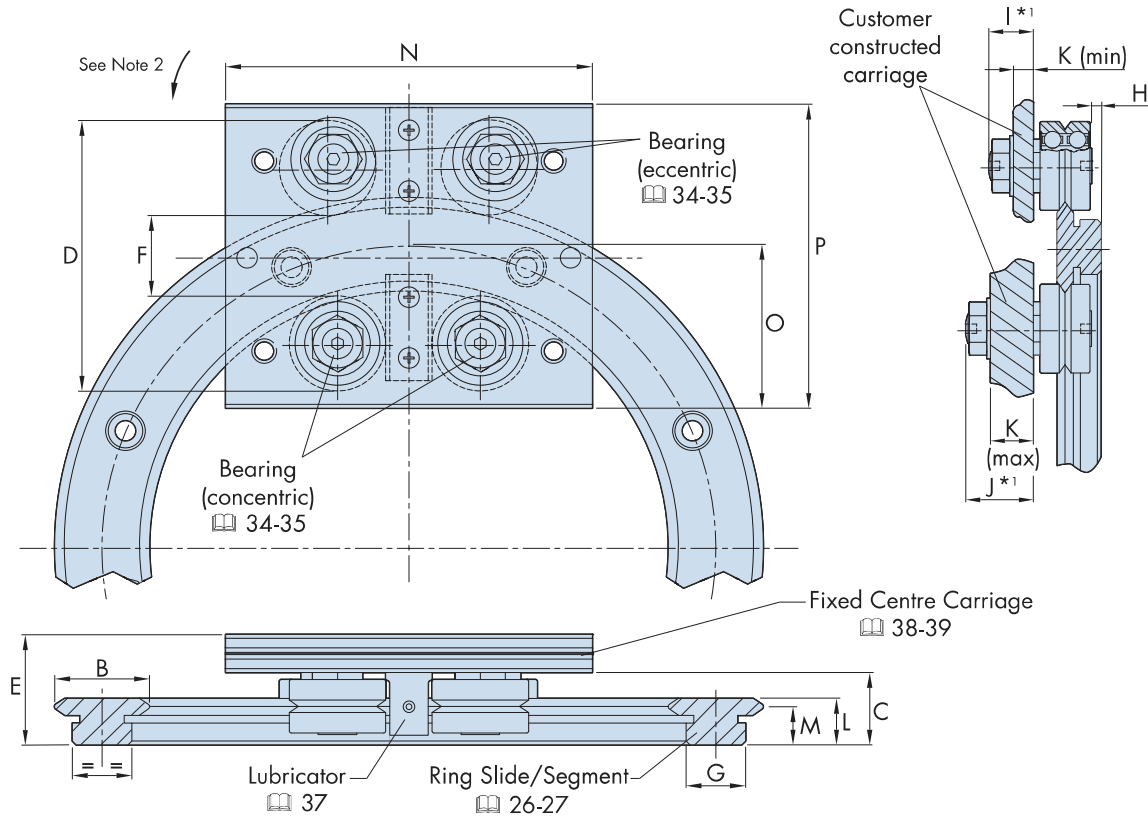

Ring Slide Ref No	For use with bearing (Ø)	A	B	C	D	E	F	G	H	I*1	J*1	K	
												Max	Min
R12 93	... J13 ...	93	12	11.67	34.7	19.0	9.1	8.6	1.5	5.8	9.5	6.7	2.2
R12 127	... J13 ...	127	12	11.67	34.7	19.0	9.1	8.6	1.5	5.8	9.5	6.7	2.2
R20 143	... J18 ...	143	20	14.75	52.5	24.75	16.3	12.4	2.4	7.4	14	10	2.4
R20 210	... J18 ...	210	20	14.75	52.5	24.75	16.3	12.4	2.4	7.4	14	10	2.4
R25 159	... J25 ...	159	25	19	71.2	30.5	20.9	15.4	2.4	9.8	19	13	2.2
R25 255	... J25 ...	255	25	19	71.2	30.5	20.9	15.4	2.4	9.8	19	13	2.2
R25 351	... J25 ...	351	25	19	71.2	30.5	20.9	15.4	2.4	9.8	19	13	2.2
R44 468	... J34 ...	468	44	24	106.0	38.5	37.8	26	2.7	13.8	22	14.8	5.2
R44 612	... J34 ...	612	44	24	106.0	38.5	37.8	26	2.7	13.8	22	14.8	5.2
R76 799	... J54 ...	799	76	38.5	172.8	58.5	64.4	50.5	3.8	17.8	30	20.4	5.7
R76 1033	... J54 ...	1033	76	38.5	172.8	58.5	64.4	50.5	3.8	17.8	30	20.4	5.7
R76 1267	... J54 ...	1267	76	38.5	172.8	58.5	64.4	50.5	3.8	17.8	30	20.4	5.7
R76 1501	... J54 ...	1501	76	38.5	172.8	58.5	64.4	50.5	3.8	17.8	30	20.4	5.7

Notes:

- Two lengths of stud are available for each size of bearing [34-35](#). Choose according to required carriage thickness.
- Offset holes in carriage for eccentric bearings necessitate adjustment in direction of arrow shown see [58](#).
- Exact theoretical values have been given for 'Q', 'R' and 'S'. Positional accuracy of dimension 'S' will determine the axis of the ring. Positional accuracy for dimensions 'Q' and 'R' are not normally critical. Holes for bearing studs should be reamed to tolerance F6 for a sliding fit.

Assembled Double Edge Ring System

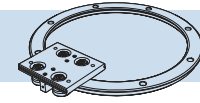

When using HepcoMotion Double Edge Ring Slides encircled by bearings as shown below it is recommended that two concentric bearings should be placed 120° apart in order to provide a datum reference. The other bearings should be the eccentric type. All eccentrics may be used where positional adjustment of the ring is required.

One or more lubricators may be fitted at convenient positions to take advantage of the increased load/life afforded by lubrication [55-57](#).

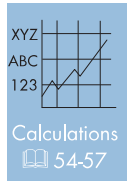
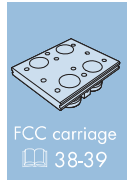
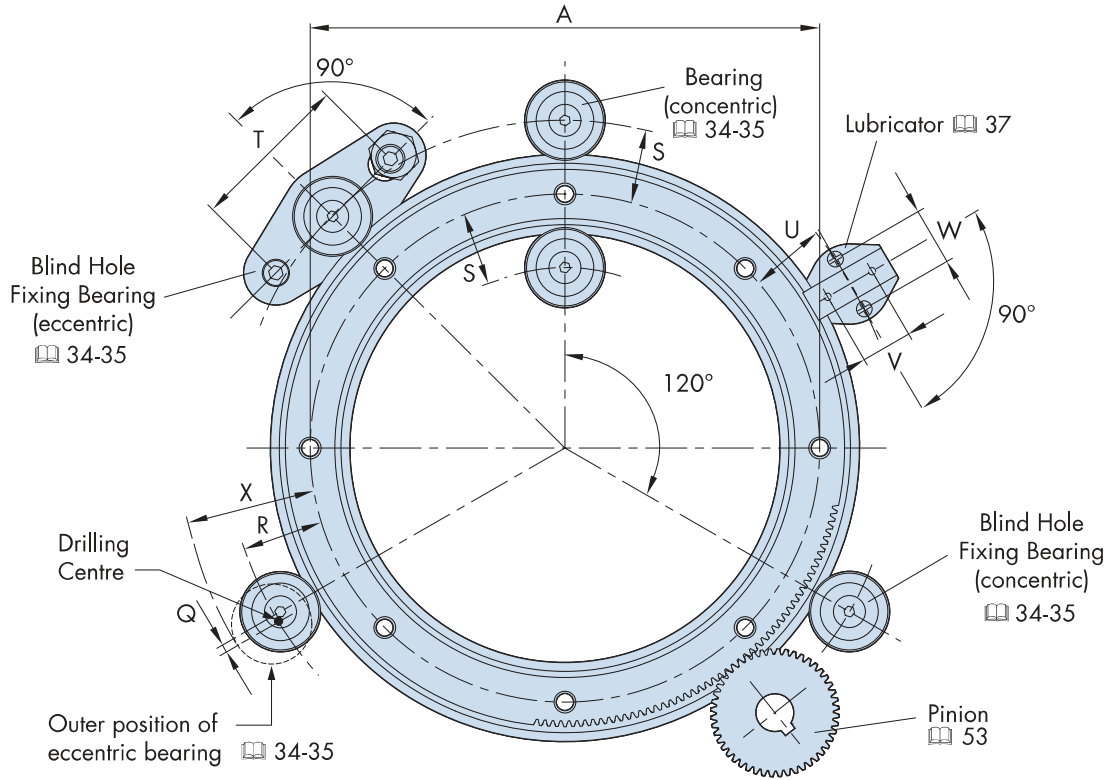

	L	M	N	O	P	Drilling Positions ³						X	
						Q	R	S	T ±0.2	U ±0.2	V ±0.2		W ±0.2
	7.7	6.2	55	22	40	1.3	12.3	10.9	30	11.5	6.5	12	20.5
	7.7	6.2	55	21	40	1.3	12.3	10.9	30	11.5	6.5	12	20.5
	10	8	75	34	64	1.8	19	17.2	38	18	13	13	30.6
	10	8	80	34	64	1.8	19	17.2	38	18	13	13	30.6
	12.25	10	95	43	80	1.9	24.9	23.0	50	22.5	16	18	40.2
	12.25	10	100	42	80	1.9	24.9	23.0	50	22.5	16	18	40.2
	12.25	10	105	42	80	1.9	24.9	23.0	50	22.5	16	18	40.2
	15.5	12.5	145	61	116	2.5	38.5	35.9	60	34.5	22	25	59.1
	15.5	12.5	150	61	116	2.5	38.5	35.9	60	34.5	22	25	59.1
	24	19.5	190	96	185	3.9	63.1	59.2	89.5	57	33	38	95.6
	24	19.5	210	96	185	3.9	63.1	59.2	89.5	57	33	38	95.6
	24	19.5	250	97	185	3.9	63.1	59.2	89.5	57	33	38	95.6
	24	19.5	270	97	185	3.9	63.1	59.2	89.5	57	33	38	95.6

Ordering details:

Simply list the components required and if relevant, bracket those you wish to be factory assembled.

Example: Assembled

- { 1 x R25 159 R180 ————  ———— 180° Ring segment [26-27](#)
- 1 x FCC 25 159 ————  ———— Fixed centre carriage [38-39](#)

Assembled Single Edge Ring System (External)

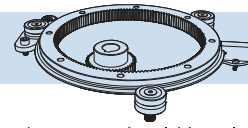

When using HepcoMotion external single edge ring slides it is recommended that two concentric bearings should be placed 120° apart in order to provide a datum reference. The other bearings should be eccentric type. All eccentrics may be used where positional adjustment of the ring is required. Either ring or bearings can be the moving element. The HepcoMotion PRT2 eccentric bearings are of double eccentric design with sufficient throw to enable disengagement of the ring without disassembly. One or more lubricators may be fitted at convenient positions to take advantage of the increased load/life afforded by lubrication 54-57.

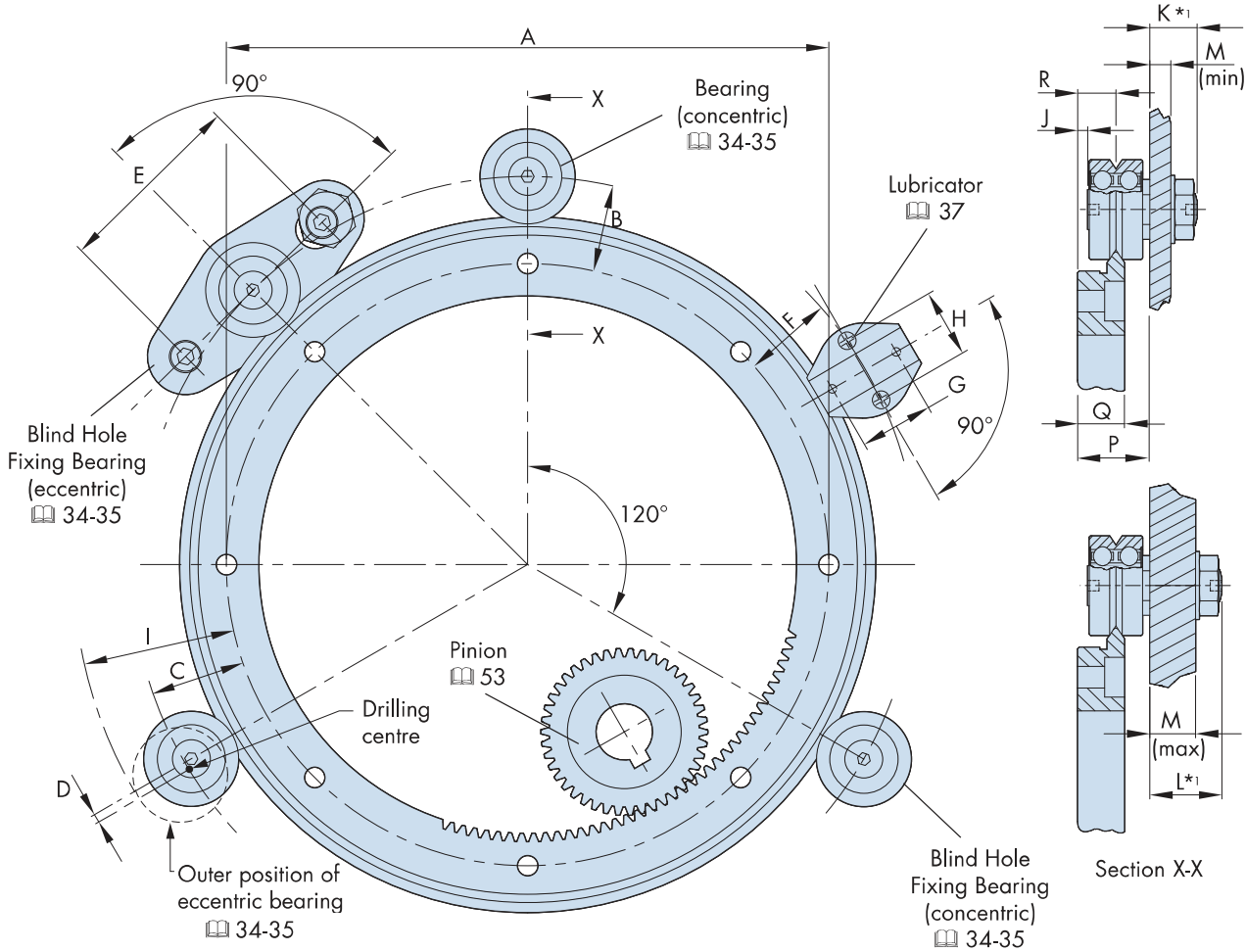

Ring Slide Ref No	For use with bearing (Ø)	A	Drilling Positions ²								I	J	K [*]	L [*]	M		P	Q	R
			B	C	D	E	F	G	H	Max					Min				
REV 156	... J18 ...	137.6	16.7	18.5	1.8	38	17.5	13	13	30.1	2.4	7.4	14	10	2.4	14.75	10	8	
REV 223	... J18 ...	204.8	16.7	18.5	1.8	38	17.5	13	13	30.1	2.4	7.4	14	10	2.4	14.75	10	8	
RES 184	... J25 ...	159	23.0	24.9	1.9	50	22.5	16	18	40.2	2.4	9.8	19	13	2.2	19	12.25	10	
RES 280	... J25 ...	255	23.0	24.9	1.9	50	22.5	16	18	40.2	2.4	9.8	19	13	2.2	19	12.25	10	
RES 376	... J25 ...	351	23.0	24.9	1.9	50	22.5	16	18	40.2	2.4	9.8	19	13	2.2	19	12.25	10	
REM 505	... J34 ...	468.5	32.4	35	2.5	60	31	22	25	55.6	2.7	13.8	22	14.8	5.2	24	15.5	12.5	
REM 655	... J34 ...	618.5	32.4	35	2.5	60	31	22	25	55.6	2.7	13.8	22	14.8	5.2	24	15.5	12.5	
REL 874	... J54 ...	820	48.3	52.1	3.9	89.5	45.5	33	38	84.6	3.8	17.8	30	20.4	5.7	38.5	24	19.5	

Notes:

- Short or long stud lengths are available for each size of bearing 34-35. Choose according to the required mounting plate thickness.
- Exact theoretical values have been given for 'B', 'C' and 'D'. Positional accuracy of dimension 'B' will determine the axis of the ring. Positional accuracy for dimensions 'C' and 'D' are not normally critical. Holes for bearing studs should be reamed to tolerance F6 for a sliding fit.

Assembled Single Edge Ring System (Internal)

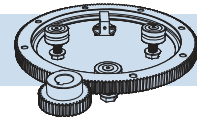

When using HepcoMotion internal single edge ring slides it is recommended that two concentric bearings should be placed 120° apart in order to provide a datum reference. The other bearings should be eccentric type. All eccentrics can be used where positional adjustment of the ring is required. Either ring or bearings may be the moving element. The HepcoMotion PRT2 eccentric bearings are of double eccentric design with sufficient throw to enable disengagement of the ring, without further disassembly. One or more lubricators may be fitted at convenient positions to take advantage of the increased load/life afforded by lubrication [54-57](#).

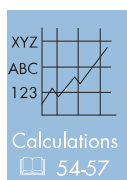
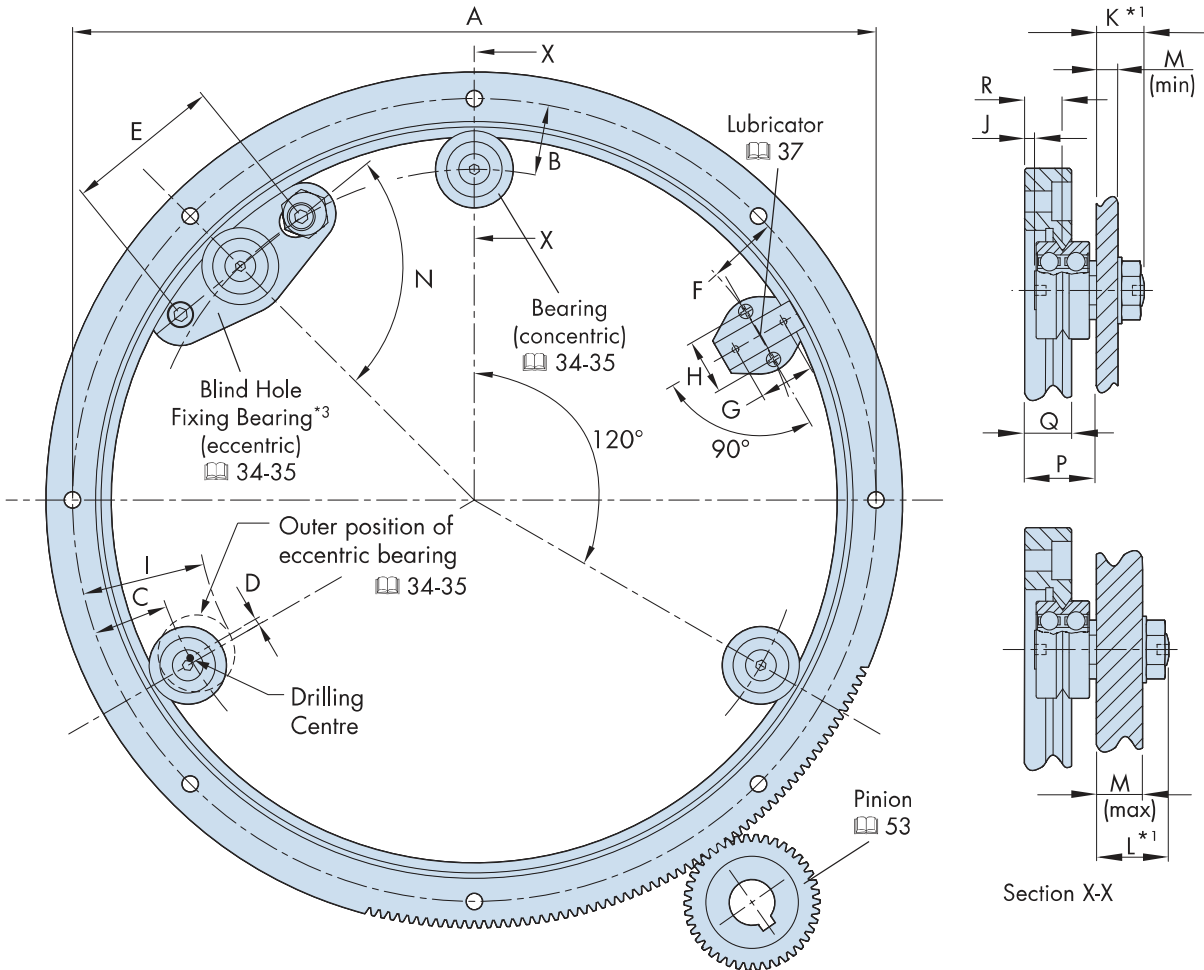

Ring Slide Ref No	For use with bearing (Ø)	A	Drilling Positions*3							I	J	K*1	L*1	M		N	P	Q	R
			B	C	D	E	F	G	H					Max	Min				
RIV 161	... J18 ...	148	16.7	18.5	1.8	38	17.5	13	13	30.1	2.4	7.4	14	10	2.4	90	14.75	10	8
RIV 228	... J18 ...	215.2	16.7	18.5	1.8	38	17.5	13	13	30.1	2.4	7.4	14	10	2.4	90	14.75	10	8
RIS 182*3	... J25 ...	165	23.0	24.9	1.9	-	22.5	16	18	40.2	2.4	9.8	19	13	2.2	-	19	12.25	10
RIS 278	... J25 ...	261	23.0	24.9	1.9	50	22.5	16	18	40.2	2.4	9.8	19	13	2.2	84	19	12.25	10
RIS 374	... J25 ...	357	23.0	24.9	1.9	50	22.5	16	18	40.2	2.4	9.8	19	13	2.2	84	19	12.25	10
RIM 482	... J34 ...	461.5	32.4	35	2.5	60	31	22	25	55.6	2.7	13.8	22	14.8	5.2	90	24	15.5	12.5
RIM 627	... J34 ...	606.5	32.4	35	2.5	60	31	22	25	55.6	2.7	13.8	22	14.8	5.2	90	24	15.5	12.5
RIL 820	... J54 ...	788	48.3	52.1	3.9	89.5	45.5	33	38	84.6	3.8	17.8	30	20.4	5.7	90	38.5	24	19.5

Notes:

- Short or long stud lengths are available for each size of bearing [34-35](#). Choose according to the required mounting plate thickness.
- Exact theoretical values have been given for 'B', 'C' and 'D'. Positional accuracy of dimension 'B' will determine the axis of the ring. Positional accuracy for dimensions 'C' and 'D' are not normally critical. Holes for bearing studs should be reamed to tolerance F6 for a sliding fit.
- The eccentric blind hole fixing bearing cannot be used with the RIS 182 ring slide as it clashes with the ring.

HepcoMotion double edge ring slides are manufactured from high quality steel, zone hardened on the V edges and precision ground all over with datum register faces provided both internally and externally for ease of location. Gear drive options are available with teeth machined into either the internal or external register face. The number of teeth on the standard external option is divisible by 4 and 12 in order to provide maximum choice of pinion size for exact ratio requirements. Customers may also choose the tapped hole option 'N' which enables the ring slide to be bolted from below. Stainless steel ring slides and segments are available for customers requiring corrosion resistance.

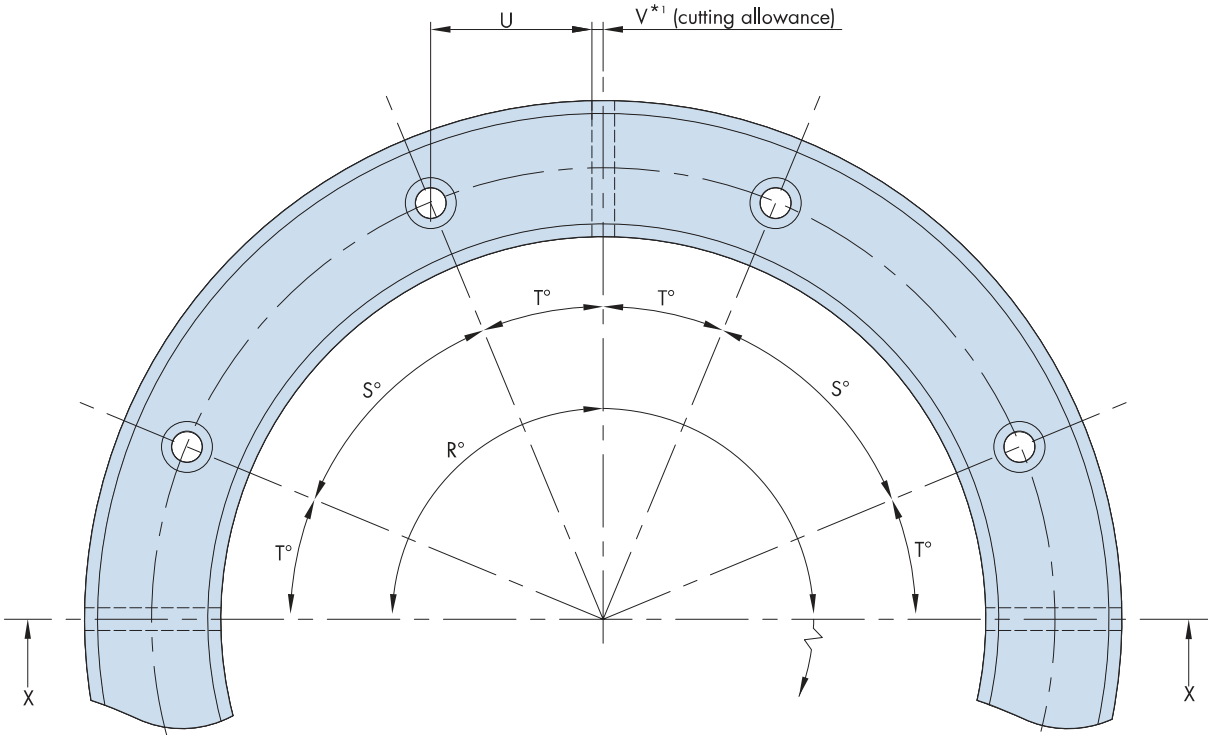
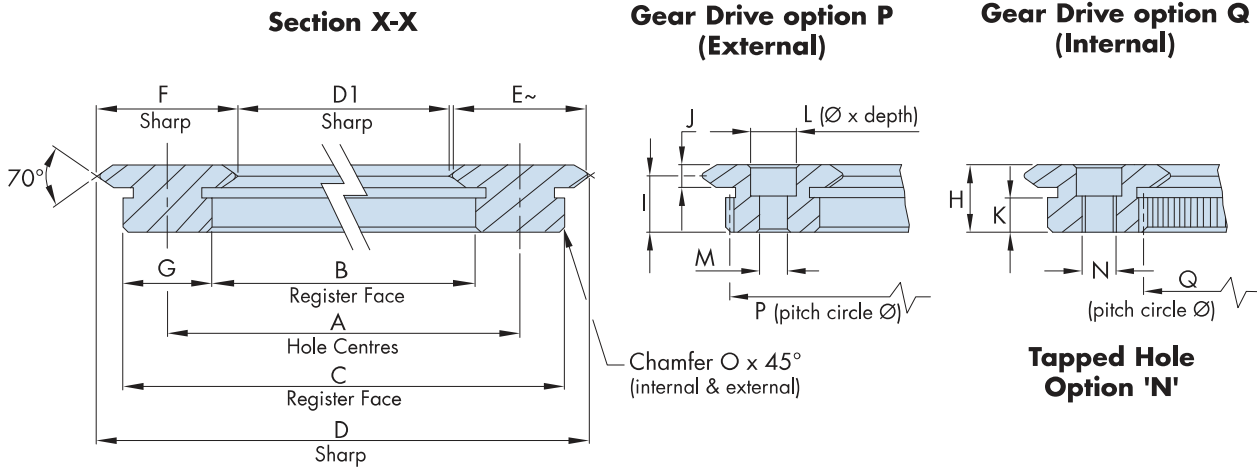

Notes:

1. Standard ring segments will be slightly less than 90° and 180° because of the cutting allowance. Full 90° and 180° segments can be supplied to customer's special order.
2. Socket head cap screws DIN912 will protrude 1mm above the surface of the R12 and R20 section slide rings. Customers requiring screws to be flush should use low head type DIN7984, available from Hepco upon request.

Double Edge Ring Slides & Segments

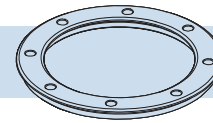

HepcoMotion double edge ring segments are cut from complete 360° ring slides and held in stock in nominal 90° and 180° segments¹. Any length segment can be cut to customer's special order and additional holes drilled as required. Although suitable for most applications, slight out of roundness and flatness may be experienced with slide rings and segments in their free unmounted condition. This may be overcome by installing against a register and bolting to a flat surface, True shape rings and segments are available on request. Please visit www.HepcoMotion.com/PRT2datauk and select datasheet No. 9 True Shape Rings & Segments.

Part Number	For use with bearing (Ø)	A ±0.2	B (J56) Register Ø	C Register Ø	D	D1	E ~	F	G	H	I ±0.025	J	K	L	M	DIN912 ² Not supplied
R12 93	... J13 ...	93	84.4 ±0.011	101.6 ±0.037	105.37	80.63	12	12.37	8.6	7.7	6.2	3	3.5	6 x 3	3.7	M3 ^{±2}
R12 127	... J13 ...	127	118.4 ±0.011	135.6 ±0.037	139.37	114.63	12	12.37	8.6	7.7	6.2	3	3.5	6 x 3	3.7	M3 ^{±2}
R20 143	... J18 ...	143	130.6 ±0.013	155.4 ±0.037	163.37	122.63	20	20.37	12.4	10	8	4.2	3.8	8 x 3.5	5.0	M4
R20 210	... J18 ...	210	197.6 ±0.015	222.4 ±0.037	230.37	189.63	20	20.37	12.4	10	8	4.2	3.8	8 x 3.5	5.0	M4
R25 159	... J25 ...	159	143.6 ±0.013	174.4 ±0.039	184.74	133.26	25	25.74	15.4	12.25	10	4.5	5.75	9 x 6	5.5	M5
R25 255	... J25 ...	255	239.6 ±0.015	270.4 ±0.041	280.74	229.26	25	25.74	15.4	12.25	10	4.5	5.75	9 x 6	5.5	M5
R25 351	... J25 ...	351	335.6 ±0.018	366.4 ±0.044	376.74	325.26	25	25.74	15.4	12.25	10	4.5	5.75	9 x 6	5.5	M5
R44 468	... J34 ...	468	442 ±0.020	494 ±0.046	512.74	423.26	44	44.74	26	15.5	12.5	6	7	11 x 7	6.8	M6
R44 612	... J34 ...	612	586 ±0.022	638 ±0.048	656.74	567.26	44	44.74	26	15.5	12.5	6	7	11 x 7	6.8	M6
R76 799	... J54 ...	799	748.5 ±0.025	849.5 ±0.051	875.74	722.26	76	76.74	50.5	24	19.5	9	12	20 x 13	14	M12
R76 1033	... J54 ...	1033	982.5 ±0.028	1083.5 ±0.054	1109.74	956.26	76	76.74	50.5	24	19.5	9	12	20 x 13	14	M12
R76 1267	... J54 ...	1267	1216.5 ±0.033	1317.5 ±0.057	1343.74	1190.26	76	76.74	50.5	24	19.5	9	12	20 x 13	14	M12
R76 1501	... J54 ...	1501	1450.5 ±0.039	1551.5 ±0.060	1577.74	1424.26	76	76.74	50.5	24	19.5	9	12	20 x 13	14	M12

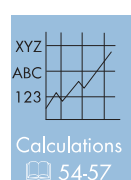
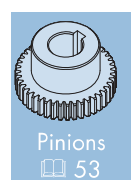
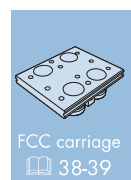

N	O	External Gear			Internal Gear			Stock Segments ¹			Holes within ±0.2 of true position		U	V	kg- (R=360°)	Part Number	
		P	MOD	No of teeth (R=360°)	Q	MOD	No of teeth (R=360°)	R°	Number of holes (R=360°)	S°	T°						
M4	0.2	100.8	0.4	252	85.2	0.4	213	90	180	360	8	45	22.5	16.8	1	0.16	R12 93
M4	0.2	134.4	0.4	336	119.2	0.4	298	90	180	360	8	45	22.5	23.3	1	0.22	R12 127
M6	0.4	153.6	0.8	192	132	0.8	165	90	180	360	8	45	22.5	26.3	1	0.45	R20 143
M6	0.4	220.8	0.8	276	199.2	0.8	249	90	180	360	8	45	22.5	39.2	1	0.66	R20 210
M8	0.5	172.8	0.8	216	145.6	0.8	182	90	180	360	8	45	22.5	29.4	1	0.77	R25 159
M8	0.5	268.8	0.8	336	241.6	0.8	302	90	180	360	8	45	22.5	47.8	1	1.2	R25 255
M8	0.5	364.8	0.8	456	337.6	0.8	422	90	180	360	12	30	15	44.4	1	1.65	R25 351
M8	0.5	492	1.0	492	444	1.0	444	90	180	360	12	30	15	58.6	2	5.1	R44 468
M8	0.5	636	1.0	636	588	1.0	588	90	180	360	16	22.5	11.25	57.7	2	6.7	R44 612
M16	1.0	846	1.5	564	751.5	1.5	501	90	180	360	16	22.5	11.25	75.9	2	25	R76 799
M16	1.0	1080	1.5	720	985.5	1.5	657	90	180	360	20	18	9	78.8	2	32	R76 1033
M16	1.0	1314	1.5	876	1219.5	1.5	813	90	180	360	20	18	9	97.1	2	41	R76 1267
M16	1.0	1548	1.5	1032	1453.5	1.5	969	90	180	360	20	18	9	115.4	2	48.7	R76 1501

Ordering details:

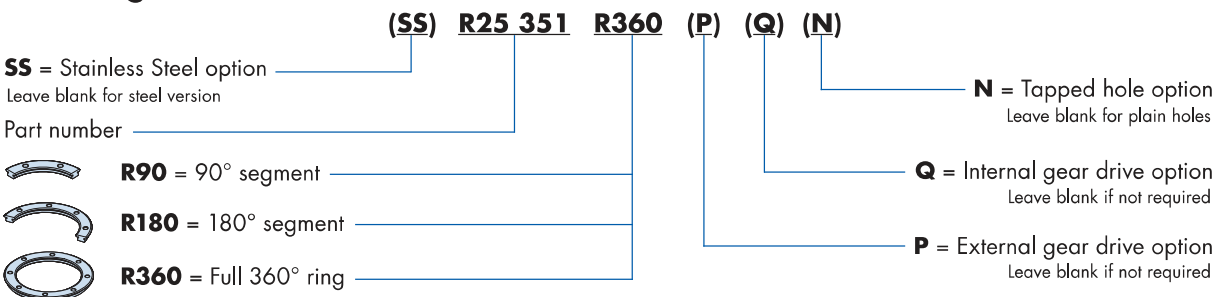

HepcoMotion single edge ring slides are manufactured from high quality steel, zone hardened on the V edge and precision ground all over. Datum register faces are provided both internally and externally for ease of location. Gear drive options are available with teeth machined into the internal register face. The number of teeth is divisible by 4 and 12 in order to provide maximum choice of pinion size for exact ratio requirements. Customers may also choose the tapped hole option 'N' which enables the ring slide to be bolted from below. Stainless steel ring slides and segments are available for customers requiring corrosion resistance.

Section X-X

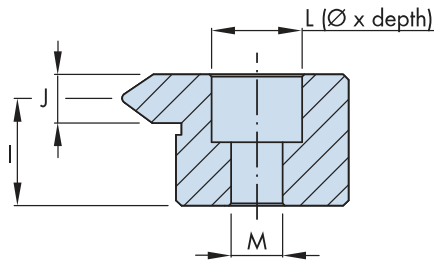
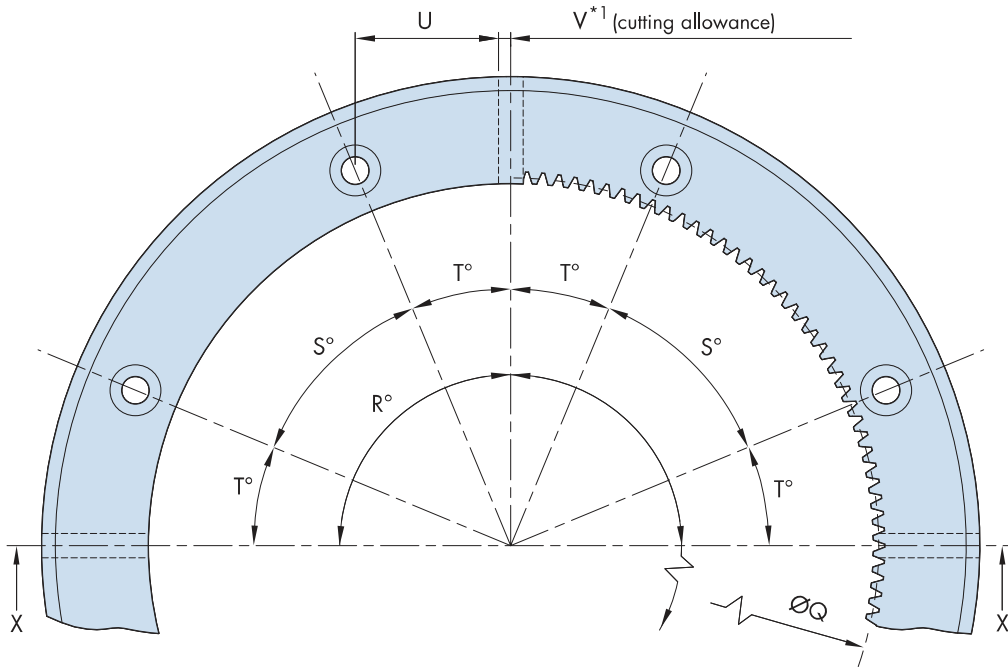
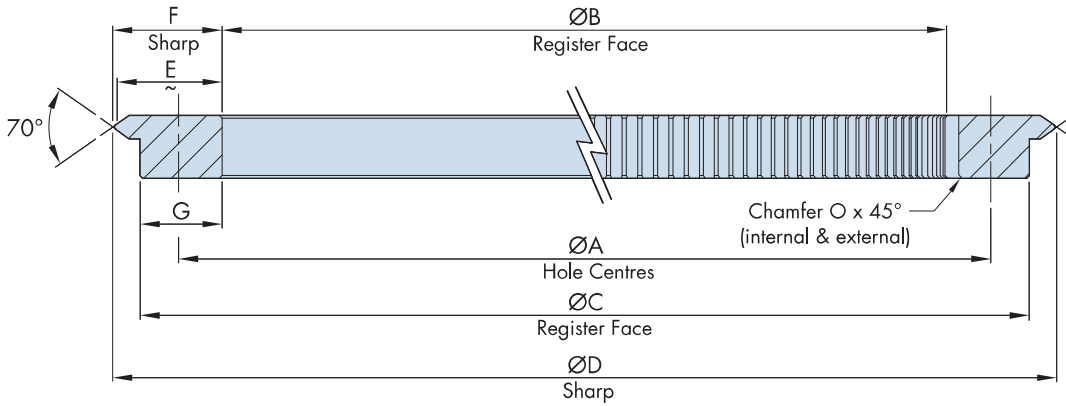

Standard Counterbored Hole

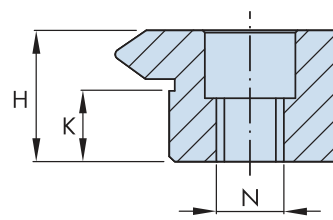

Tapped Hole Option N

Notes:

1. Standard ring segments will be slightly less than 90° and 180° because of the cutting allowance. Full 90° and 180° segments can be supplied to customer's special order.

External Single Edge Ring Slides & Segments

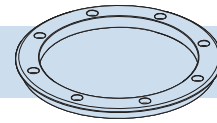

HepcoMotion ring segments are cut from complete 360° ring slides and held in stock in nominal 90° and 180° segments. Any length segment can be cut to customer's special order and additional holes drilled as required. Although suitable for most applications, slight out of roundness and flatness may be experienced with slide rings and segments in their free unmounted condition. This may be overcome by installing against a register and bolting to a flat surface. True shape rings and segments are available on request. Please visit www.HepcoMotion.com/PRT2datauk and select datasheet No. 9 True Shape Rings & Segments. Larger diameter single edge ring slides are available in the HDRT range for which there is a separate catalogue 61.

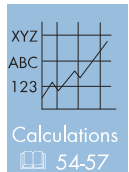
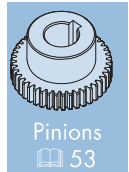
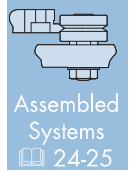

Part Number	For use with bearing (Ø)	A	B (JS6)	C	D	E	F	G	H	I	J	K	L	M	DIN912 (not supplied)
		±0.2	Register Ø	Register Ø		~					±0.025				
REV 156	... J18 ...	137.6	124.6 ±0.013	148.6 ±0.037	156.97	15.8	16.18	12	10	8	4.2	3.8	8 x 4.2	5.0	M4
REV 223	... J18 ...	204.8	191.8 ±0.015	215.8 ±0.037	224.17	15.8	16.18	12	10	8	4.2	3.8	8 x 4.2	5.0	M4
RES 184	... J25 ...	159	142 ±0.013	174 ±0.039	184.74	20.8	21.37	16	12.25	10	4.5	5.75	10 x 5.2	5.5	M5
RES 280	... J25 ...	255	238 ±0.015	270 ±0.041	280.74	20.8	21.37	16	12.25	10	4.5	5.75	10 x 5.2	5.5	M5
RES 376	... J25 ...	351	334 ±0.018	366 ±0.044	376.74	20.8	21.37	16	12.25	10	4.5	5.75	10 x 5.2	5.5	M5
REM 505	... J34 ...	468.5	447.5 ±0.020	487.5 ±0.046	506.24	28.8	29.37	20	15.5	12.5	6	7.0	11 x 6.2	6.8	M6
REM 655	... J34 ...	618.5	597.5 ±0.022	637.5 ±0.048	656.24	28.8	29.37	20	15.5	12.5	6	7.0	11 x 6.2	6.8	M6
REL 874	... J54 ...	820	788 ±0.025	848 ±0.051	874.74	42.8	43.37	30	24	19.5	9	12	18 x 10.3	11	M10

N	O	Internal Gear			Stock Segments ¹			Number of holes (R=360°)	Holes within ±0.2 of true position		U	V	kg~ (R=360°)	Part Number
		Q	MOD	No of teeth (R=360°)	R°				S°	T°				
M6	0.4	126	0.7	180	-	-	360	8	45	22.5	25.3	1	0.42	REV 156
M6	0.4	193.2	0.7	276	-	-	360	8	45	22.5	38.2	1	0.63	REV 223
M8	0.5	144	1	144	90	180	360	8	45	22.5	29.4	1	0.78	RES 184
M8	0.5	240	1	240	90	180	360	8	45	22.5	47.8	1	1.27	RES 280
M8	0.5	336	1	336	90	180	360	12	30	15	44.4	1	1.75	RES 376
M8	0.5	450	1.25	360	90	180	360	12	30	15	58.6	2	3.93	REM 505
M8	0.5	600	1.25	480	90	180	360	16	22.5	11.25	58.3	2	5.18	REM 655
M16	1.0	792	2	396	-	-	360	16	22.5	11.25	78	2	15.64	REL 874

Ordering details:

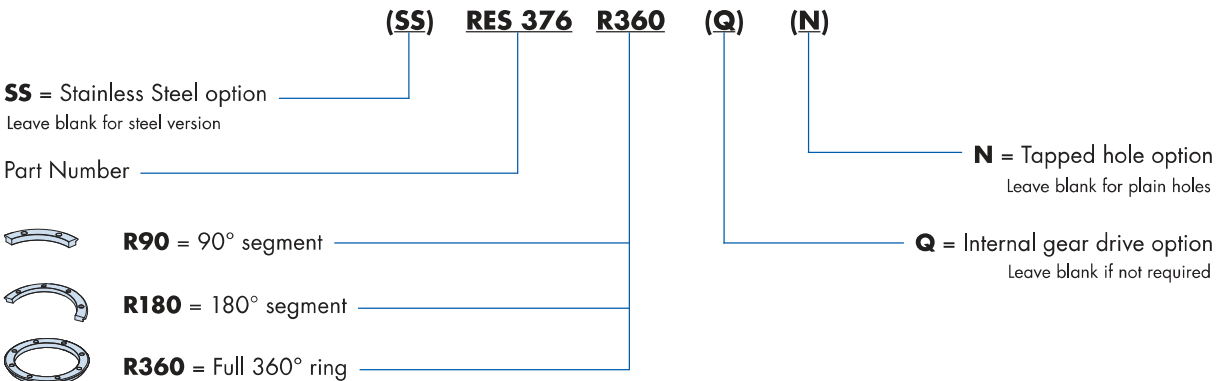

HepcoMotion single edge ring slides are manufactured from high quality steel, zone hardened on the V edge and precision ground all over. Datum register faces are provided both internally and externally for ease of location. Gear drive options are available with teeth machined into the external register face. The number of teeth is divisible by 4 and 12 in order to provide maximum choice of pinion size for exact ratio requirements. Customers may also choose the tapped hole option 'N' which enables the ring slide to be bolted from below. Stainless steel ring slides and segments are available for customers requiring corrosion resistance.

Section X-X

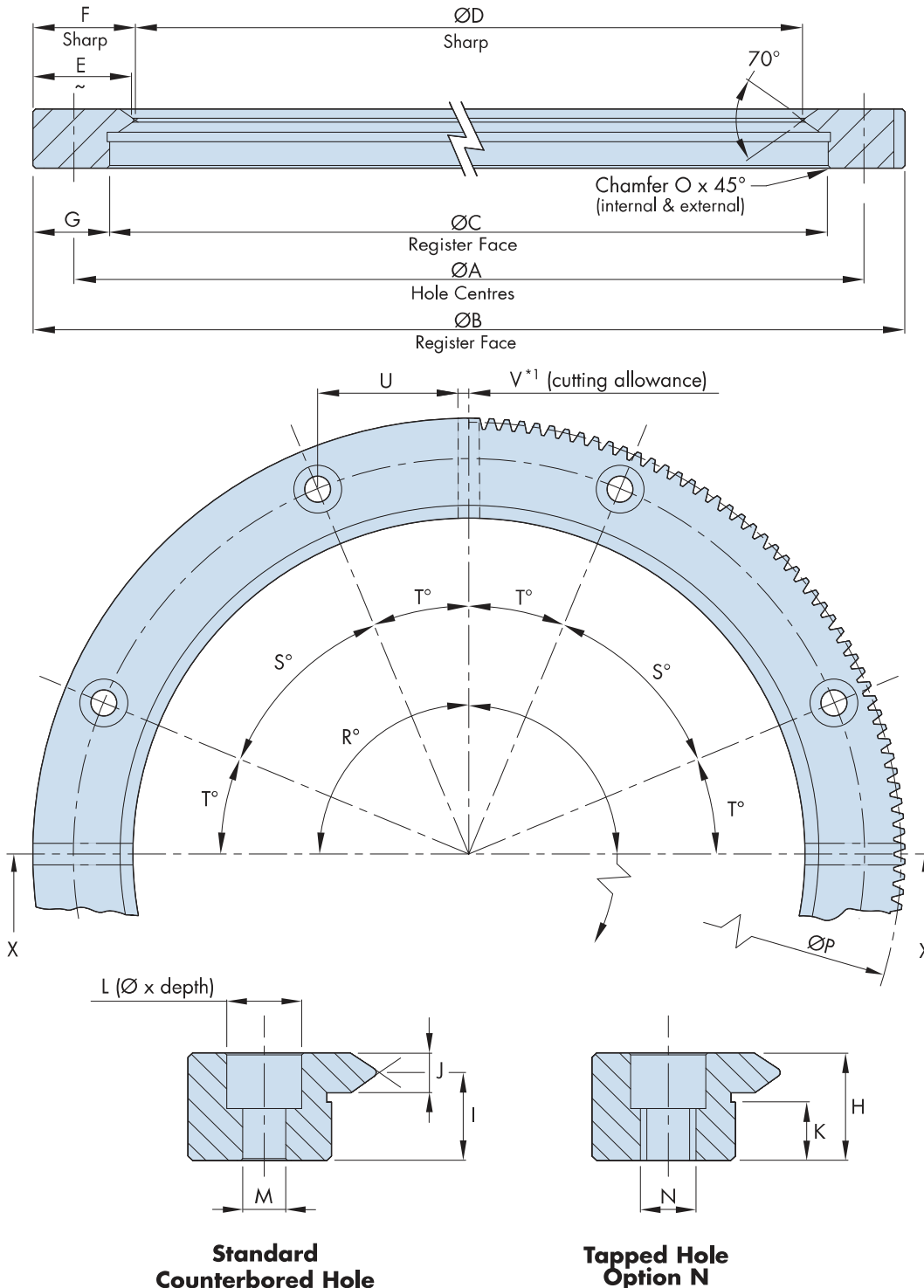

Notes:

1. Standard ring segments will be slightly less than 90° and 180° because of the cutting allowance. Full 90° and 180° segments can be supplied to customer's special order.

Internal Single Edge Ring Slides & Segments

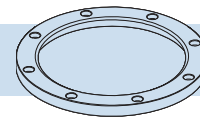

HepcoMotion single edge ring segments are cut from complete 360° ring slides and held in stock in nominal 90° and 180° segments. Any length segment can be cut to customer's special order and additional holes drilled as required. Although suitable for most applications, slight out of roundness and flatness may be experienced with slide rings and segments in their free unmounted condition. This may be overcome by installing against a register and bolting to a flat surface, True shape rings and segments are available on request. Please visit www.HepcoMotion.com/PRT2datauk and select datasheet No. 9 True Shape Rings & Segments. Larger diameter single edge ring slides are available in the HDRT range for which there is a separate catalogue 61.

Part Number	For use with bearing (Ø)	A	B (J56)	C	D	E	F	G	H	I	J	K	L	M	DIN912 (not supplied)
		±0.2	Register Ø	Register Ø	Register Ø	~	±0.025								
RIV 161	... J18 ...	148	161 ±0.013	137 ±0.037	128.63	15.8	16.18	12	10	8	4.2	3.8	8 x 4.2	5.0	M4
RIV 228	... J18 ...	215.2	228.2 ±0.015	204.2 ±0.037	195.83	15.8	16.18	12	10	8	4.2	3.8	8 x 4.2	5.0	M4
RIS 182	... J25 ...	165	182 ±0.015	150 ±0.039	139.26	20.8	21.37	16	12.25	10	4.5	5.75	10 x 5.2	5.5	M5
RIS 278	... J25 ...	261	278 ±0.016	246 ±0.041	235.26	20.8	21.37	16	12.25	10	4.5	5.75	10 x 5.2	5.5	M5
RIS 374	... J25 ...	357	374 ±0.018	342 ±0.044	331.26	20.8	21.37	16	12.25	10	4.5	5.75	10 x 5.2	5.5	M5
RIM 482	... J34 ...	461.5	482.5 ±0.020	442.5 ±0.046	423.76	28.8	29.37	20	15.5	12.5	6	7	11 x 6.2	6.8	M6
RIM 627	... J34 ...	606.5	627.5 ±0.022	587.5 ±0.048	568.76	28.8	29.37	20	15.5	12.5	6	7	11 x 6.2	6.8	M6
RIL 820	... J54 ...	788	820 ±0.028	760 ±0.051	733.26	42.8	43.37	30	24	19.5	9	12	18 x 10.3	11	M10

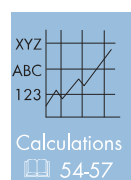
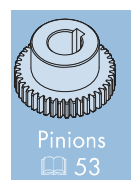

N	O	External Gear			Stock Segments*1			Number of holes (R=360°)	Holes within ±0.2 of true position		U	V	kg~ (R=360°)	Part Number
		P	MOD	No of teeth (R=360°)	R°				S°	T°				
M6	0.4	159.6	0.7	228	-	-	360	8	45	22.5	27.3	1	0.42	RIV 161
M6	0.4	226.8	0.7	324	-	-	360	8	45	22.5	40.2	1	0.63	RIV 228
M8	0.5	180	1	180	90	180	360	8	45	22.5	30.6	1	0.78	RIS 182
M8	0.5	276	1	276	90	180	360	8	45	22.5	48.9	1	1.27	RIS 278
M8	0.5	372	1	372	90	180	360	12	30	15	45.2	1	1.75	RIS 374
M8	0.5	480	1.25	384	90	180	360	12	30	15	57.7	2	3.93	RIM 482
M8	0.5	625	1.25	500	90	180	360	16	22.5	11.25	57.2	2	5.18	RIM 627
M16	1.0	816	2	408	-	-	360	16	22.5	11.25	74.9	2	15.64	RIL 820

Ordering details:

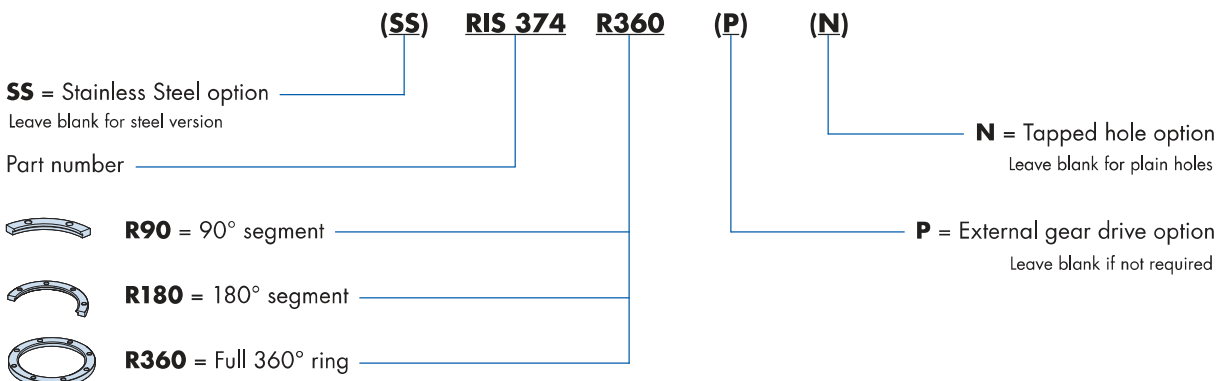

Ring Discs

HepcoMotion Ring Discs are ideally suited for turntable applications where a precision platform is required for the mounting of components. Ring discs are made from high quality steel, hardened on the V edge and precision ground all over*1. An external datum register is provided and a gear drive option is available in which the number of teeth is divisible by 4 and 12 in order to provide maximum choice of pinion size for exact ratio requirements.

All key dimensions are the same as for the corresponding size of Double Edge Ring Slide  27.

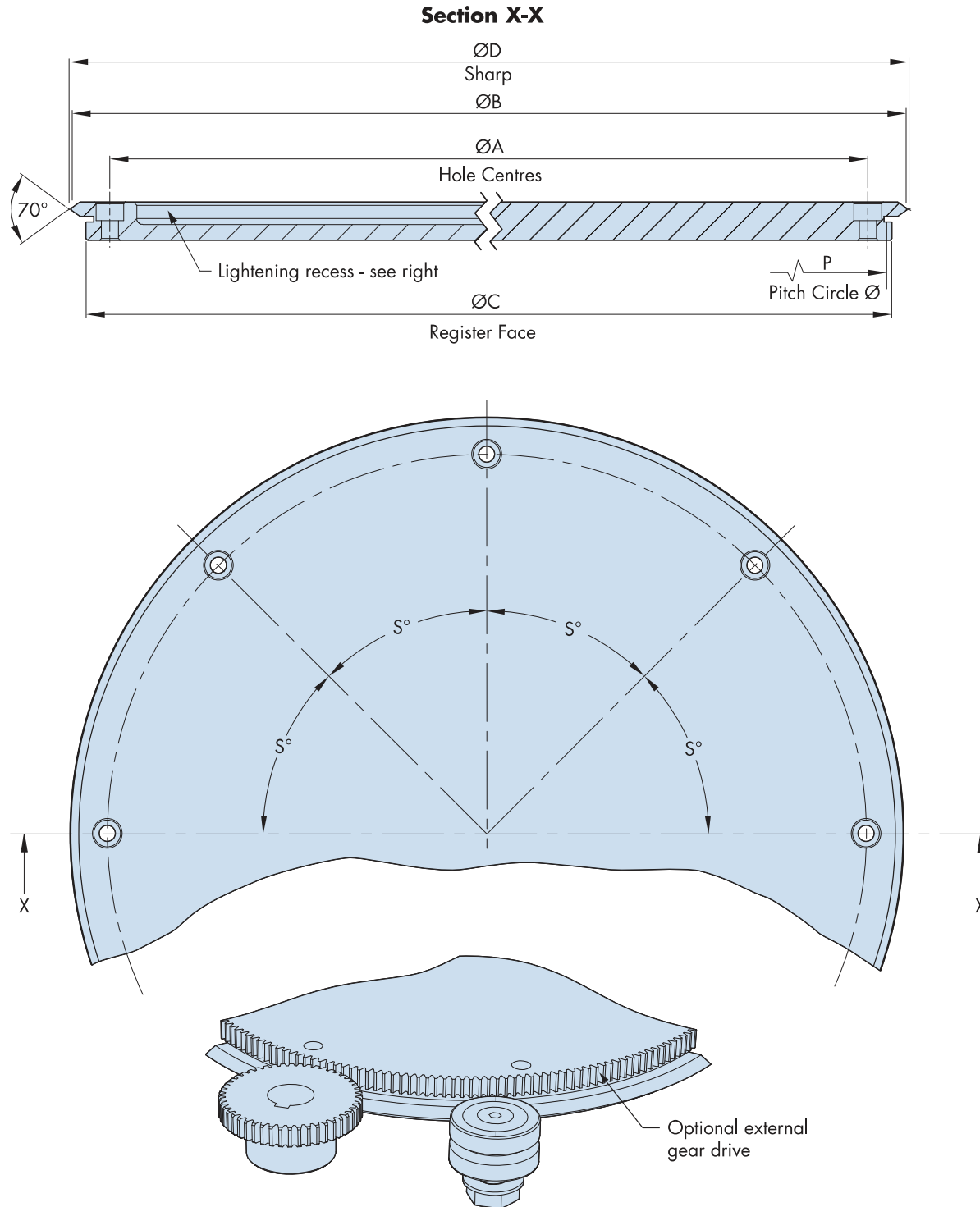

Notes:

1. The internal faces of the lightening recess in the lightweight version are not ground. On stainless steel ring discs, these surfaces are polished.

Ring Discs

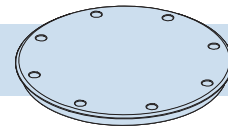

For applications where weight is an issue, a lightweight version (option 'L') is available. Stainless steel ring discs are also available, as is the tapped hole option 'N'.

Ring discs can be made to customer's specification, on request. Variations include other diameters, different thicknesses, special holes, registers or other mounting features, and alternative patterns of lightening recess.

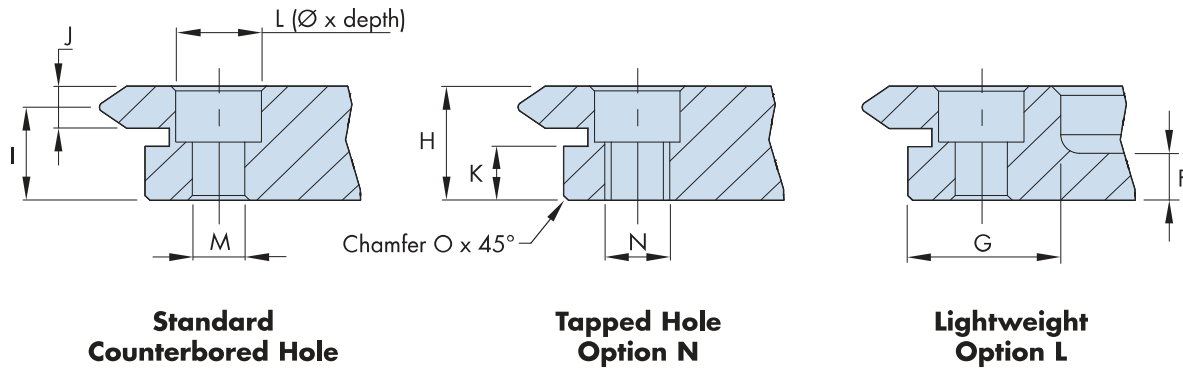
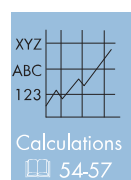

Part Number	For use with bearing (Ø)	A ±0.2	B	C Register Ø	D	F	G	H	I ±0.025	J	K	L
RD25 159	... J25 ...	159	184	174.4 ±0.039	184.74	5	15.4	12.25	10.0	4.5	5.75	9 x 6
RD25 255	... J25 ...	255	280	270.4 ±0.041	280.74	5	15.4	12.25	10.0	4.5	5.75	9 x 6
RD25 351	... J25 ...	351	376	366.4 ±0.044	376.74	5	15.4	12.25	10.0	4.5	5.75	9 x 6
RD44 468	... J34 ...	468	512	494 ±0.046	512.74	6	26	15.5	12.5	6	7	11 x 7

M	DIN912 (not supplied)	N	O	External Gear			Number of Holes	Holes within ±0.2 of true position S°	kg~		Part Number
				P	MOD	No of teeth			Standard	Lightweight	
5.5	M5	M8	0.5	172.8	0.8	216	8	45	2.3	1.4	RD25 159
5.5	M5	M8	0.5	268.8	0.8	336	8	45	5.5	3.0	RD25 255
5.5	M5	M8	0.5	364.8	0.8	456	12	30	10.2	5.2	RD25 351
6.8	M6	M8	0.5	492	1	492	12	30	23.6	12.2	RD44 468

Ordering details:

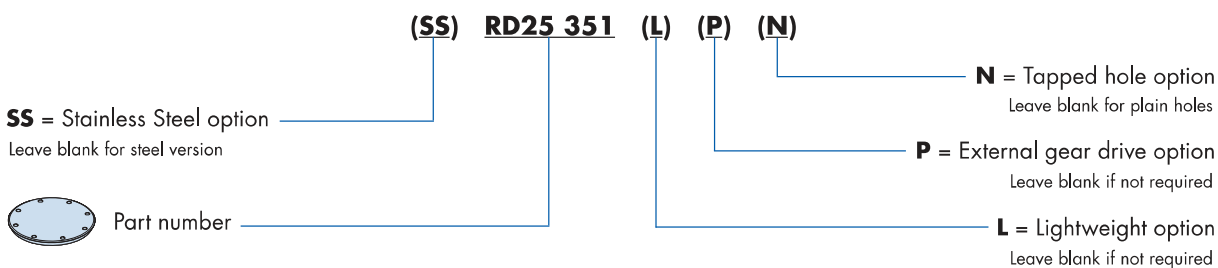

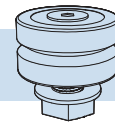

HepcoMotion PRT2 bearings are available in five sizes to suit the five ring slide sections. Bearings can be used with more than one ring size: for details, please visit www.HepcoMotion.com/PRT2datauk and select datasheet No. 11 PRT2 mix and match.

The following bearing formats and fixing methods cater for most design requirements:

Twin Bearing type has the smoothest running quality, is easiest to adjust and offers some compliance to accommodate misalignment. It has two deep groove ball bearings on a single stud, and is the usual choice for many systems.

Double Row Bearing type (DR) incorporates a one-piece outer ring with two ball tracks. It offers more load capacity, life and stiffness, and copes better with debris. Dimensions are identical to the twin bearings type. DR bearings are more demanding of installation tolerances and it is recommended that they are specified with the CHK option*4.

Nitrile Sealed option (NS) available for both bearing formats, provides better sealing against water or debris than the metal shielded type. A small increase in friction may result.

See 20 for the bearing and lubrication selector.

Through Fixing Type (RSJ/RLJ)

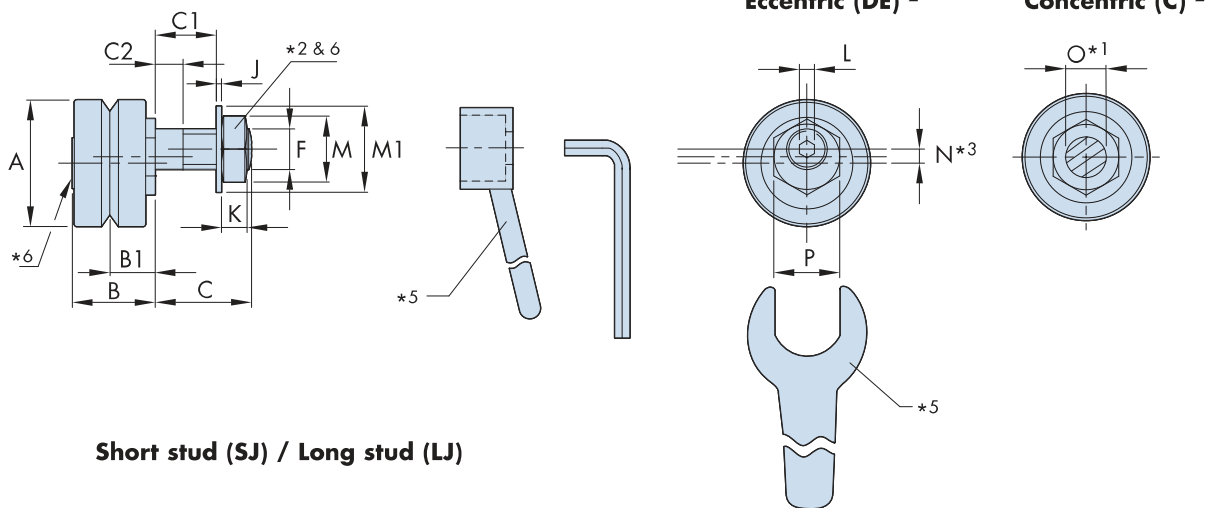

Short stud (SJ) / Long stud (LJ)

Part Number	For use with				A	B	B1*4	C		C1		C2	
								RSJ	RLJ	RSJ	RLJ	RSJ	RLJ
... J13 ...	R12	-	-	TNMS	12.7	10.1	5.47	5.8	9.5	3	6.7	2.2	2.4
... J18 ...	R20	-	REV, RIV	TNV	18	12.4	6.75	7.4	14	3.4	10	2.4	2.5
... J25 ...	R25	RD25	RES, RIS	TNS	25	16.6	9	9.8	19	3.8	13	2.2	4.9
... J34 ...	R44	RD44	REM, RIM	TNM	34	21.3	11.5	13.8	22	6.6	14.8	5.2	5.9
... J54 ...	R76	-	REL, RIL	TNL	54	34.7	19	17.8	30	8.2	20.4	5.7	7.9

Q	R*3	S	S1	T	T1	T2	U ±0.1	U1	V	W	X	Y	Z
1.5	1.0	6.25	6.6	8.5	3.75	6.75	30	47.5	8	20	M3	5.5	8
2	1.2	8	10.5	10	4	8	38	54	11	24.5	M4	7	7
3	1.5	7	9	12	5	10	50	72	14	32	M5	8.5	10
4	2.0	9.5	8.5	17.5	6.5	12.5	60	90.5	17	42	M6	10	14
8	3.0	14.5	16.4	23.5	10.5	18.5	89.5	133	25	62	M8	13	20

Notes:

- It is recommended that holes to suit bearing mounting studs should be reamed to tolerance F6 for a sliding fit.
- Nuts and washers are supplied with both concentric and eccentric RSJ/RLJ type bearings.
- 'N' is the eccentric offset due to the double eccentric design ($2 \times N = \text{total stroke}$). R dimension is both the eccentric offset of the adjusting nut and total stroke at the bearing centreline.
- Controlled height (CHK) bearings are selected in $\pm 0.010\text{mm}$ bands in respect of the B1 dimension. They are supplied in sets of up to 50 parts as standard, with larger sets on request.
- For adjusting tool part numbers see table. For adjustment procedure and fixing nut tightening torques see 58.
- Fasteners for the through fixing type bearings are black on the concentric version and bright zinc plated on the eccentric version for identification purposes, except stainless steel type.
- Stainless steel bearings are only available nitrile sealed.

Bearings

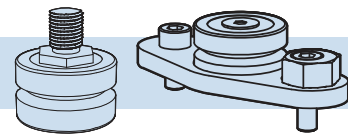

Through Hole Fixing type is available in two stud lengths covering most thicknesses of mounting plate, the short version being used in HepcoMotion carriages. Both are available in **Concentric (C)** which provides a datum for the system, and **Eccentric (DE)** to provide enough adjustment to permit disengagement of a carriage or ring encircled by bearings 58.

All bearings are available in a **Controlled Height version (CHK)** which minimises variation in the B1 dimension*4. This is desirable in high precision applications and is recommended whenever Double Row Bearings are used.

Blind Hole Fixing type (RBHJ) allows mounting into a solid machine base where through mounting holes are not possible, or where the thickness of the mounting plate is too great. The Blind Hole Fixing type is also useful where adjustment from the front is preferred or where access to the opposite side of the mounting hole is restricted. They are available in **Concentric (C)** which are fixed, or **Eccentric (E)** which are adjustable.

All bearings are greased for life internally. Customers are strongly advised to provide lubrication to the interface between bearings and ring slide by specifying HepcoMotion Lubricators 37 or Bleed Lubrication system 52. Lubrication greatly increases load capacity and life.

Blind Hole Fixing Type (RBHJ)

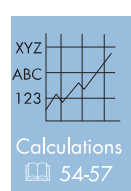
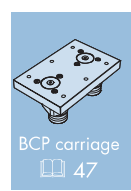
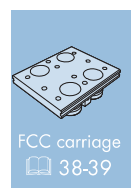
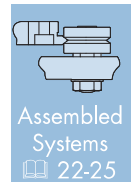
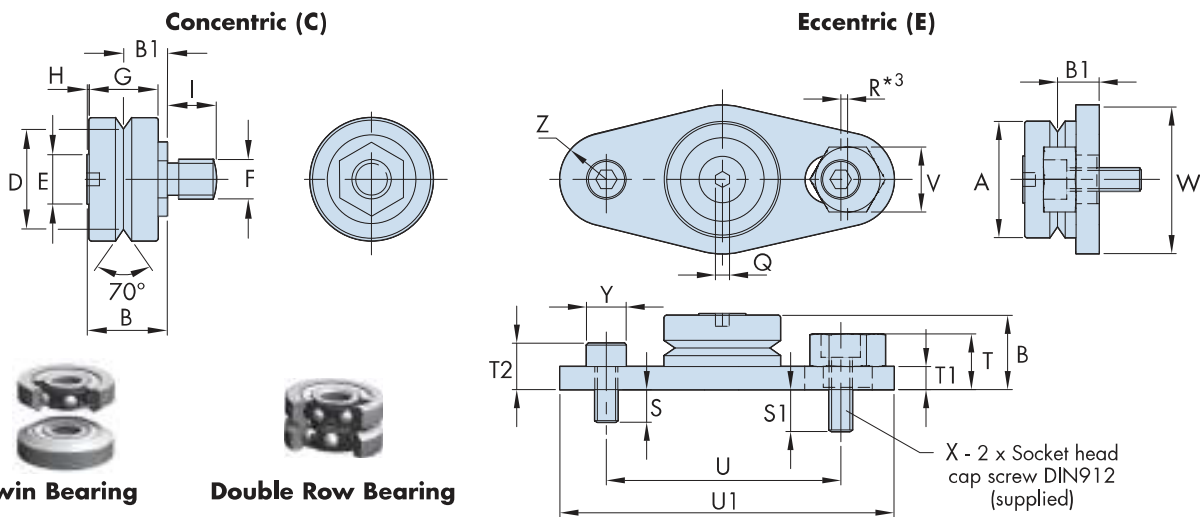

D ±0.025	E	F Metric Fine	G	H	I	J	K	L	M	M1	N*3	O*1 +0.0 -0.03	P
9.51	5	M4 x 0.5	8	0.5	5.8	0.8	2.2	-	7	9	1.9	4	7
14.00	7	M6 x 0.75	10	0.6	7.4	0.8	3.2	2.5	10	13	2.6	6	11
20.27	10	M8 x 1	14	0.5	9.8	1	5	3	13	17	2.75	8	13
27.13	12	M10 x 1.25	18	0.7	13.8	1.25	6	4	17	21	3.6	10	15
41.76	25	M14 x 1.5	28	1.6	17.8	1.6	8	6	22	28	5.5	14	27

Adjusting Wrench ¹⁵	Socket Tool ¹⁵	g~				Options Available					Part Number
		RSJ..C/E	RLJ..C/E	RBHJ..C	RBHJ..E	- Metal shields	NS ⁷ Nitrile Seals	- Twin Bearing	DR Double Row	CHK Controlled Height	
AT13	-	8	8	7	27	x	✓	✓	x	✓	... J13 ...
AT18	RT6	19	20	18	45	x	✓	✓	✓	✓	... J18 ...
AT25	RT8	48	51	43	105	✓	✓	✓	✓	✓	... J25 ...
AT34	RT10	115	120	105	235	✓	✓	✓	✓	✓	... J34 ...
AT54	RT14	415	425	390	800	✓	✓	✓	✓	✓	... J54 ...

Ordering details:

(SS) = Stainless steel option*7
Leave blank for steel version

Fixing type: **RSJ** = Short stud
RLJ = Long stud
RBHJ = Blind hole fixing

Bearing diameter options are 13, 18, 25, 34 & 54

(DR) = Double row bearing
Leave blank for twin bearing

(NS) = Nitrile sealed option *7
Leave blank for metal shields

(CHK) = Controlled height *4
Leave blank if not required

Journal type: **C** = Concentric (fixed)
E = Eccentric (adjustable, RBHJ only)
DE = Eccentric (adjustable RSJ/RLJ only)

Floating Bearings

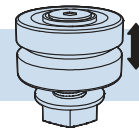

HepcoMotion Floating Bearings incorporate caged needle rollers and are designed to provide axial movement (float) of the V position. This is especially useful where two rings or track systems are mounted apart, see application example 14.

The float compensates for parallelism tolerances between the opposing V's, eliminating additional loading and maintaining consistent running quality. Three sizes are available, each to correspond with one ring slide section, but they can be used with other sections. Please visit www.HepcoMotion.com/PRT2datauk and select datasheet No. 11 PRT2 mix and match.

Two stud lengths are available covering most thicknesses of mounting plate, the short version being compatible with HepcoMotion carriage plates. Both versions are available in **Concentric (C)** which provides a datum (in radial direction) for the system, and **Eccentric (DE)** which provides sufficient adjustment to allow disengagement of a carriage or ring encircled by bearings 58.

All bearings are greased for life internally. Customers are strongly advised to provide lubrication to the interface between bearings and ring slide by specifying HepcoMotion Lubricators 37 or bleed lubrication system 52. Lubrication greatly increases load capacity and life.

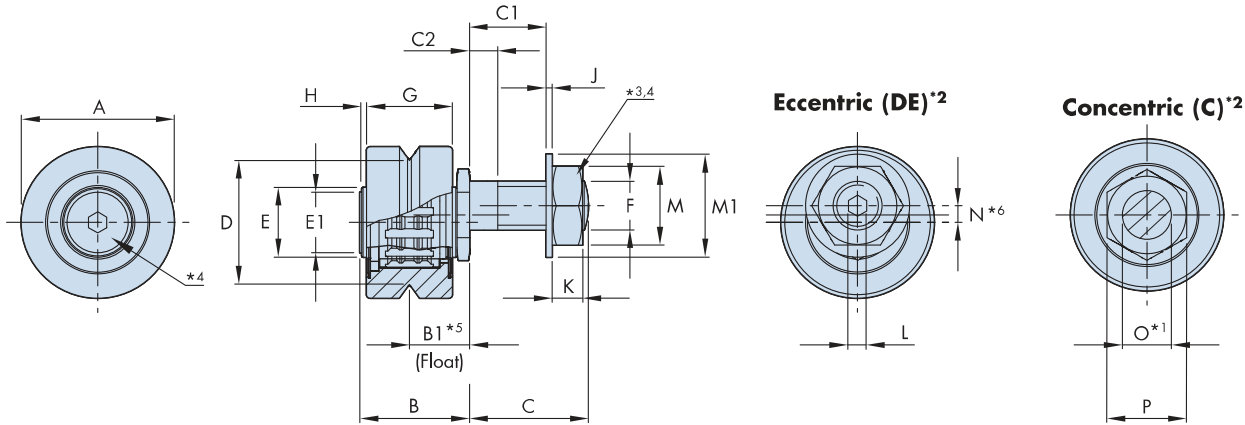

Short stud (RSFJ) / Long stud (RLFJ)

Part Number	For use with				A	B	B1*5		C		C1		C2		D ±0.025	E	E1	F Metric Fine	G	H ~
							Min	Max	RSFJ	RLFJ	RSFJ	RLFJ	RSFJ	RLFJ						
... FJ25 ...	R25	RD25	RES, RIS	TNS	25	18.1	9	10.5	9.8	19	3.8	13	3.4	4.9	20.27	11.5	10	M8 x 1	14	0.8
... FJ34 ...	R44	RD44	REM, RIM	TNM	34	23.2	11.5	13.5	13.8	22	6.6	14.8	5.2	5.9	27.13	16	12	M10 x 1.25	18	1
... FJ54 ...	R76	-	REL, RIL	TNL	54	37.2	19	21.6	17.8	30	8.2	20.4	5.7	7.9	41.76	28	25	M14 x 1.5	28	1.3

J	K	L	M	M1	N*6	O*1 +0 -0.03	P	Adjusting Wrench *3	Socket Tool *3	g~	Max Working Load Capacity (N)	Bearing Static (Co) and Dynamic (C) Radial Load Capacities (N)		Part Number	
												Co	c		
1	5	3	13	17	2.75	8	13	AT25	RT8	58	60	1500	6100	4900	... FJ25 ...
1.25	6	4	17	21	3.6	10	15	AT34	RT10	130	135	3000	12500	11500	... FJ34 ...
1.6	8	6	22	28	5.5	14	27	AT54	RT14	495	505	5000	28900	21500	... FJ54 ...

Notes:

- It is recommended that holes to suit bearing mounting studs should be reamed to tolerance F6 for a sliding fit.
- Nuts and washers are supplied with both concentric and eccentric RSFJ/RLFJ type bearings.
- For adjustment procedure and bearing fixing nut tightening torques see 58.
- Fasteners are black on the concentric version and bright zinc plated on the eccentric version for identification purposes.
- 'B1' dimension is the min/max axial movement of the V centre.
- 'N' is the eccentric offset due to the double eccentric design (2 x N = total stroke).

Ordering details:

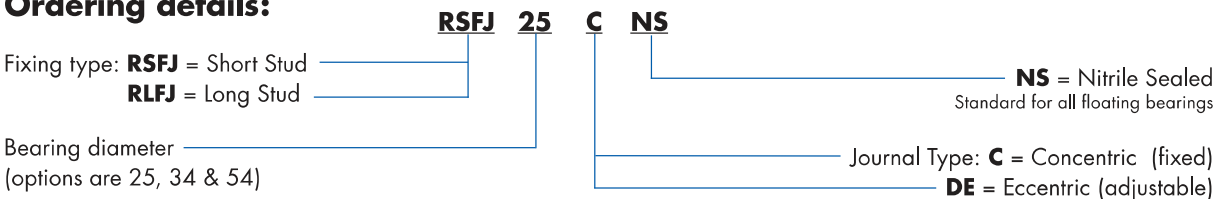

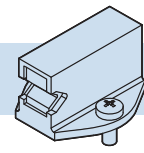

HepcoMotion lubricators are made from impact resistant plastic and house a sprung oil impregnated felt wiper designed to apply a constant film of oil to the working surfaces of the ring slide without imposing undue friction. The application of oil significantly increases the load and life of the system. Either type of lubricator can be used with individual ring slides, segments and ring discs. The compact type can be used with Hepco fixed centre carriage plates. Customers may also consider using the HepcoMotion bleed lubrication facility suitable for track systems [52](#).

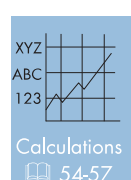
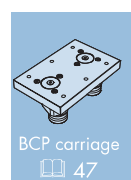
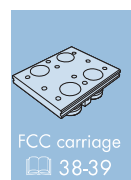
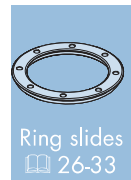

Compact Type (C)

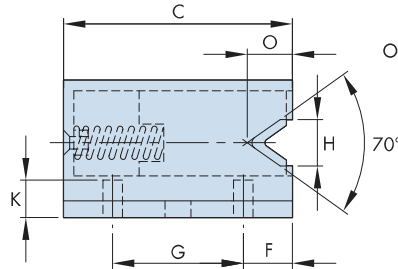
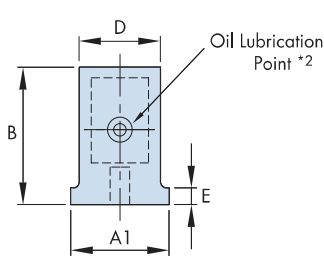

Flanged Type (F)

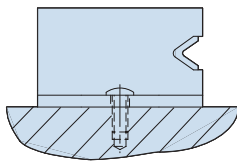
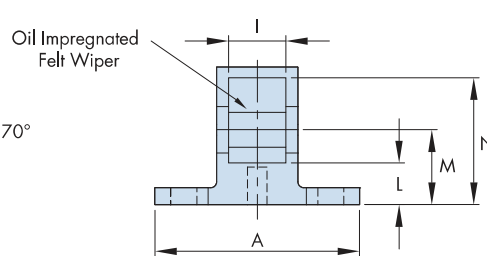

**Blind Fixing
Flanged Type**

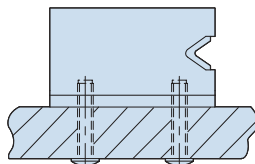

**Through Fixing
Compact Type**

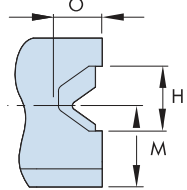

**Option - FB*3
For use with
Floating Bearings**

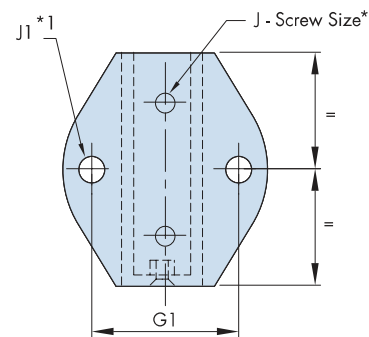

Fixing Methods

Part Number	For Use with				Type F	Type C	B	C	D	E	F	G ±0.1	G1 ±0.1
					A	A1							
LB 12	R12	-	-	TNMS 12	17	7	10	13	5.2	2	3	6.5	12
LB 20	R20	-	REV, RIV	TNV 20	19	8	12	22.5	6.5	2	4.75	13	13
LB 25	R25	RD25	RES, RIS	TNS 25, TNSE	25	12	16.5	28	9.9	2	6	16	18
LB 44	R44	RD44	REM, RIM	TNM 44, TNME	34	17	20	38	15	2.4	8	22	25
LB 76	R76	-	REL, RIL	TNL 76	50	25	33.5	57	22.7	4.5	12	33	38

H	H1	I	J Ø x Length	J1		K	L	M	N	O	g~	Part Number
				Screw Size	Hole Ø							
3.1	-	3	2.5 x 5	M2.5 x 6	2.7	2.5	3	5.46	9	2.2	2	LB 12
7.2	-	4	2.5 x 10	M2.5 x 6	2.7	2.5	3.5	6.75	10.75	4.5	3	LB 20
5.5	7.1	7	3 x 10	M3 x 8	3.2	4.5	5	9	15.25	5.5	6	LB 25
7	9	11	3 x 16	M4 x 10	4.2	5.5	6.25	11.5	18.25	8	16	LB 44
10	12.6	18	3.5 x 22	M5 x 12	5.2	9	10	19	31.5	11.5	44	LB 76

Notes:

- 2 machine screws with cross-recessed pan heads to DIN7985A are supplied for fixing the flanged type lubricator (see J1 in table). Additionally, 2 self tapping screws for plastic with PT thread form and cross-recessed pan heads are supplied for the compact type lubricator (see J in table).
- Lubrication interval depends on length of stroke, duty and environmental factors. Replenish lubricant as necessary using a 68 viscosity EP mineral oil.
- Size 25,44 & 76 lubricators are available with increased clearance "H1" to accommodate the "V float" of the floating bearings [36](#).

Ordering details:

Part Number **LB 25** **F** **(FB)**

Lubricator Type: **F** = Flanged Type **FB** = Floating Bearing option
C = Compact Type

Specify only for lubricators used with floating bearings

The HepcoMotion Fixed Centre Carriage is designed for use with track systems with unidirectional bends of a common radii \square 40 and for use with double edge ring slides and segments \square 26-27. The unique geometry enables carriages on a track system to travel from straight to curve with negligible play in the transition zone. Such play as may develop is not detrimental to the performance of the system*1.

Carriages are available with twin or double row (DR) bearings \square 34-35, and with floating bearings \square 36. Carriages with twin bearings have the smoothest running quality and have some compliance to accommodate misalignment. Carriages with DR bearings have better load capacity and stiffness. Due to the rigidity of DR bearings, carriages with this option are supplied as Controlled Height (CHK)*5 as standard.

The corrosion resistant version has stainless steel bearings and fasteners, and a high performance USDA approved surface treatment to the aluminium carriage plate in place of the standard anodised finish.

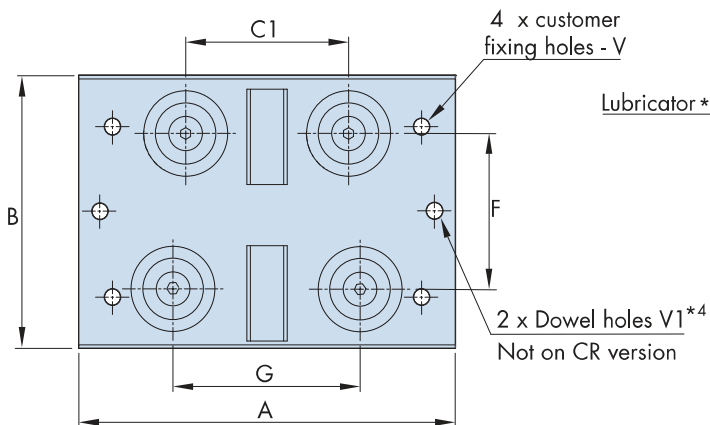
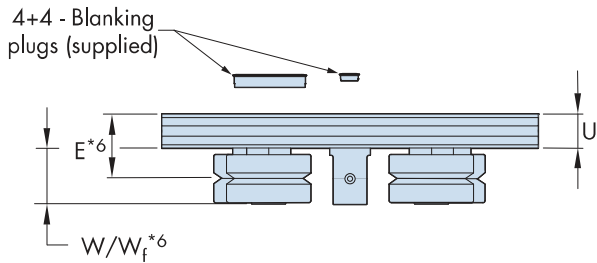
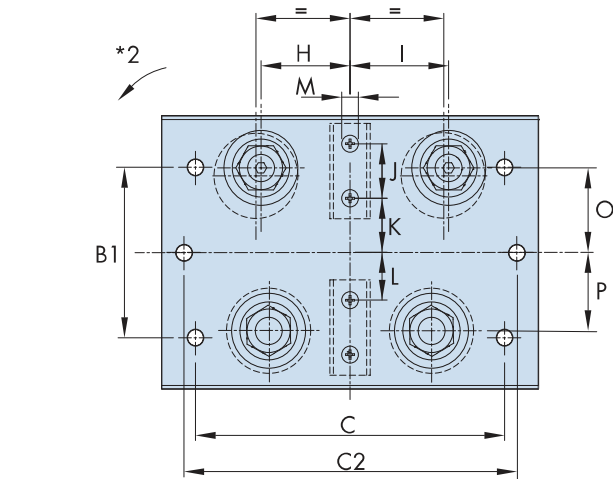

Fixed Centre Carriage with Clamping Brake

Ratchet locking lever (variable position)

The HepcoMotion fixed centre carriage with clamping brake provides a secure method to lock the carriage in position whilst stationary. It may be used on double edge ring slides and segments but not on track systems. It is available in sizes 25, 44 & 76. Full product details are on the web: visit www.HepcoMotion.com/PRT2datauk and select datasheet No. 7.

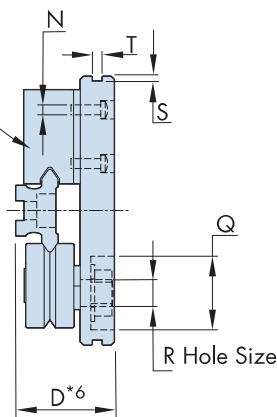

Notes:

1. Fixed centre carriages will experience a reduction in preload or a slight clearance as they pass between the curves and straights on a track system, but this is rarely an issue. This clearance is detailed on \square 57. Please note the FCC25 159 has a larger than normal clearance. Bogie carriages \square 47 are not subject to clearance.
2. Offset holes in carriage for eccentric bearings necessitate adjustment rotation in the direction shown.
3. It is recommended that carriages are fitted with lubricators. The quantity of lubricators may be reduced in systems with many carriages or where the bleed lubrication facility is used \square 52.
4. Dowel holes V1 define the centre and may be used for location purposes. They are not included as standard on the corrosion resistant version, but are available on special request.
5. CHK controlled height carriages use CHK bearings \square 35 and are supplied in sets, matched by their E dimension. It is recommended to specify CHK for precision applications or where consistent carriage heights are important. CHK is standard for carriages with DR bearings.
6. The W dimension is greater for carriages with floating bearings - see Wf in the table. Dimensions D and E will change for carriages with floating bearings. The amount of float is indicated by dimension B1 \square 36.

Fixed Centre Carriage

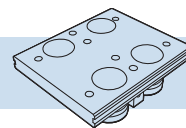

Part Number	For Use with			A	B	B1	C	C1	C2 ±0.01	D*6	E*6	F	G	H	I	J	K
FCC12 93	R12 93 R360/R180/R90	TR12 93	55	40	25	48	20	45	19	12.8	21.9	25.52	11.11	14.41	6.5	9.3	
FCC12 127	R12 127 R360/R180/R90	TR12 127	55	40	25	48	20	45	19	12.8	21.9	23.84	10.27	13.56	6.5	8.8	
FCC20 143	R20 143 R360/R180/R90	TR20 143	75	64	40	60	25	65	24.75	16.75	34.4	32.03	13.76	18.27	13	13	
FCC20 210	R20 210 R360/R180/R90	TR20 210	80	64	40	65	28	70	24.75	16.75	34.4	33.06	14.28	18.87	13	12.7	
FCC25 159*1	R25 159 R360/R180/R90	TR25 159	95	80	50	85	37	80	30.5	20.5	46	50.15	22.70	27.46	16	17.1	
FCC25 255	R25 255 R360/R180/R90	TR25 255	100	80	50	80	36.5	85	30.5	20.5	46	43.86	19.55	24.31	16	15.9	
FCC25 351	R25 351 R360/R180/R90	TR25 351	105	80	50	85	40	90	30.5	20.5	46	45.66	20.45	25.21	16	15.6	
FCC44 468	R44 468 R360/R180/R90	TR44 468	145	116	75	120	65	125	38.5	26	71.9	75.95	35.22	40.73	22	25.8	
FCC44 612	R44 612 R360/R180/R90	TR44 612	150	116	75	125	70	130	38.5	26	71.9	78.80	36.64	42.16	22	25.5	
FCC76 799	R76 799 R360/R180/R90	TR76 799	190	185	100	160	90	165	58.5	39	118.5	104.56	49.13	55.44	33	43	
FCC76 1033	R76 1033 R360/R180/R90	TR76 1033	210	185	100	180	110	185	58.5	39	118.5	123.48	58.59	64.90	33	43	
FCC76 1267	R76 1267 R360/R180/R90	TR76 1267	250	185	100	205	130	225	58.5	39	118.5	142.82	68.26	74.57	33	44	
FCC76 1501	R76 1501 R360/R180/R90	TR76 1501	270	185	100	225	150	245	58.5	39	118.5	162.38	78.04	84.35	33	44	

L	M (Ø x depth)	NØ	O	P	Q (Ø x depth)	RØ (hole size) (F6)	S	T	U	V	V1Ø (K6)	W	Wf	g~	Part Number
7.8	4.5 x 4.5	2.7	11.89	10.94	12.5 x 4.8	4 +0.018 +0.010	1	3	7.34	M4	4 +0.002 -0.006	10.1	-	70	FCC12 93
7.8	4.5 x 4.5	2.7	11.89	10.94	12.5 x 4.8	4 +0.018 +0.010	1	3	7.34	M4	4 +0.002 -0.006	10.1	-	70	FCC12 127
12.3	4.5 x 2.5	2.7	18.49	17.19	15.8 x 7	6 +0.018 +0.010	1.5	4	10	M5	4 +0.002 -0.006	12.4	-	190	FCC20 143
12.3	4.5 x 2.5	2.7	18.49	17.19	15.8 x 7	6 +0.018 +0.010	1.5	4	10	M5	4 +0.002 -0.006	12.4	-	200	FCC20 210
14	5.3 x 4.5	3.2	24.38	23.01	22 x 8.4	8 +0.022 +0.013	2	5	11.5	M6	6 +0.002 -0.006	16.6	18.1	400	FCC25 159*1
14	5.3 x 4.5	3.2	24.38	23.01	22 x 8.4	8 +0.022 +0.013	2	5	11.5	M6	6 +0.002 -0.006	16.6	18.1	410	FCC25 255
14	5.3 x 4.5	3.2	24.38	23.01	22 x 8.4	8 +0.022 +0.013	2	5	11.5	M6	6 +0.002 -0.006	16.6	18.1	420	FCC25 351
23	5.3 x 4.5	3.2	38.25	35.94	25 x 8.7	10 +0.022 +0.013	2	6	14.5	M8	8 +0.002 -0.007	21.3	23.2	1080	FCC44 468
23	5.3 x 4.5	3.2	38.25	35.94	25 x 8.7	10 +0.022 +0.013	2	6	14.5	M8	8 +0.002 -0.007	21.3	23.2	1100	FCC44 612
40	8.0 x 6.0	3.8	63.76	59.25	32.1 x 13.5	14 +0.027 +0.016	4	8	20	M10	10 +0.002 -0.007	34.7	37.2	3460	FCC76 799
40	8.0 x 6.0	3.8	63.76	59.25	32.1 x 13.5	14 +0.027 +0.016	4	8	20	M10	10 +0.002 -0.007	34.7	37.2	3660	FCC76 1033
40	8.0 x 6.0	3.8	63.76	59.25	32.1 x 13.5	14 +0.027 +0.016	4	8	20	M10	10 +0.002 -0.007	34.7	37.2	4050	FCC76 1267
40	8.0 x 6.0	3.8	63.76	59.25	32.1 x 13.5	14 +0.027 +0.016	4	8	20	M10	10 +0.002 -0.007	34.7	37.2	4250	FCC76 1501

Ordering details:

(CR) **FCC 44 612** (LB) (DR) (NS) (CHK)

CR⁴ = Corrosion resistant option
Leave blank if not required

Part number _____

LB³ = Lubricator option
Leave blank if not required

Clamping Brake option available,
please refer to PRT2 datasheet No.7

www.HepcoMotion.com/PRT2datauk

CHK⁵ = Controlled height option 35
Standard with DR bearings
Leave blank if not required for twin bearing version

NS = Nitrile sealed bearings fitted 34
Leave blank for metal shields

Bearing type: **FJ** = Floating bearings 36

DR = double row bearings 34

Leave blank for twin bearings

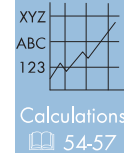
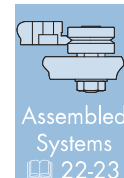

HepcoMotion track systems provide a unique method of achieving an almost limitless variety of open or closed circuits by combining straight slides with curved slides. They can be used in any orientation, from horizontal to vertical. Some of the more common track configurations are illustrated on this, and the opposite page. Any number of carriages can be accommodated, either the fixed centre economy type or the bogie type which enables 'S' bends or bends of varying radii to be negotiated and which has a larger platform for mounting purposes. A unique jacking screw facility incorporated within the track system enables perfect alignment of straight slides to curved slides. Various drive possibilities exist some of which are illustrated 14-18. Lubrication of the system is achieved either by means of lubricators incorporated within the fixed centre carriages or by means of the HepcoMotion bleed lubrication facility 52 which injects lubricant direct to the V faces of the track. The relevant dimensions of individual track system slides are held on record to enable spares and replacements to be supplied. Track systems are also available in stainless steel for applications requiring greater corrosion resistance.

Rectangular track system

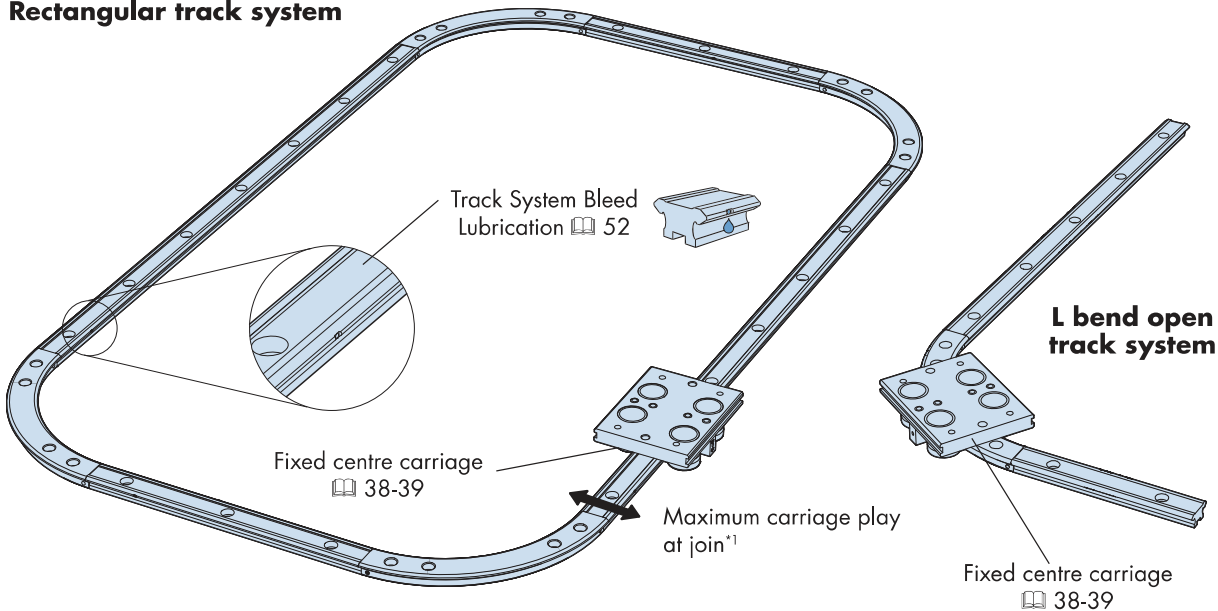

Oval track system

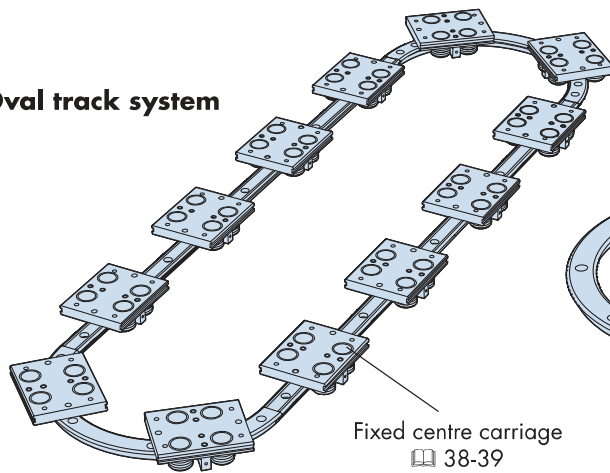

Triangular track system

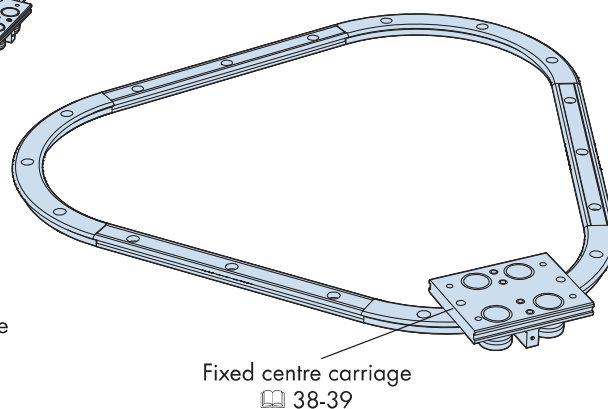

Installation

Installation requires manual drilling and setting. Track systems are also available in suitable grade to correspond with customers pre-drilled mounting holes. Please visit www.HepcoMotion.com/PRT2datauk and select datasheet No. 2 Installation details.

Notes:

1. With the fixed centre carriage, some slight play develops as each pair of opposing bearings traverse the join between straight and curve. This is rarely an issue in use. The maximum play acting in the direction of the arrows is given in the table on 57.
2. Standard curved segments will be slightly less than 90° and 180° due to the cutting allowance. This is not detrimental to the smoothness of travel across the joins. Full 90° and 180° segments and segments to any number of degrees can be supplied on request.

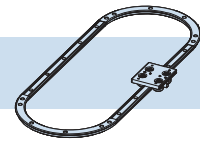

Bi-directional track system with variable bend radii

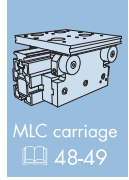
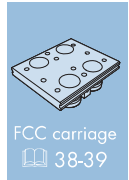
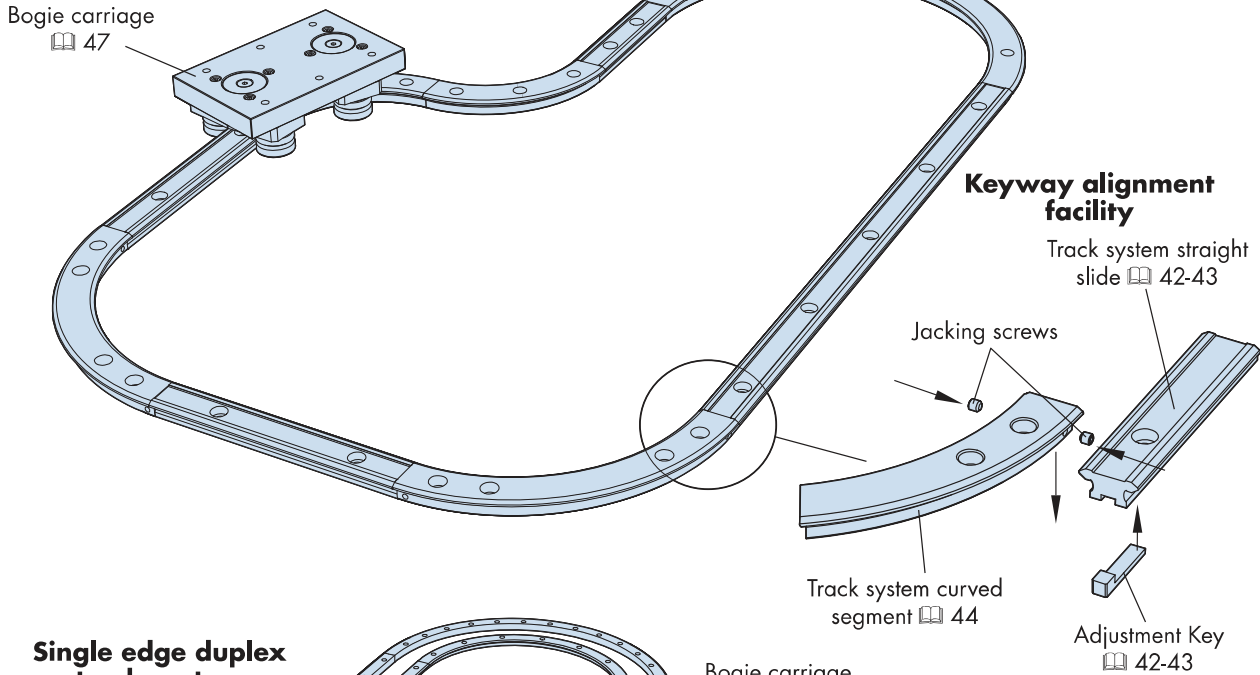

Single edge duplex track system

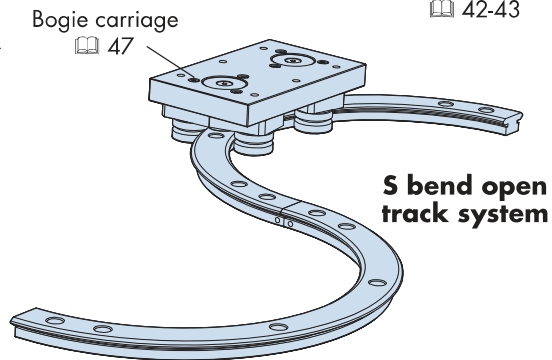
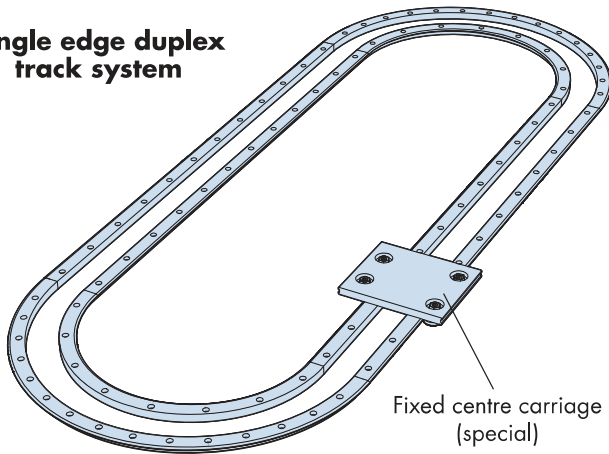

Track system straight slide 42-43

Track system curved segment 44

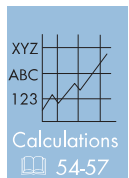
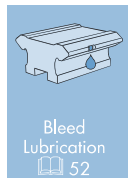
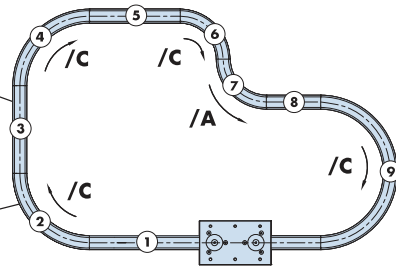

Ordering details:

Simply list the curved segments and straight slide part numbers in a clockwise sequence beginning at any point on the track system, see above plan view of track system. Curved segments should be designated suffix 'C' for a clockwise bend and suffix 'A' for an anticlockwise bend. Final item should be quantity and part number of the carriages required. For grade of track suitable for pre-drilled holes, specify track system type 'P'. To specify bleed lubrication facility 52.

- (1) TNS25 B420 2 x AK — Track system straight slide 42-43
- (2) TR25 255 R90/C — Clockwise curved segment 44
- (3) TNS25 B159 2 x AK — Track system straight slide 42-43
- (4) TR25 255 R90/C — Clockwise curved segment 44
- (5) TNS25 B165 2 x AK — Track system straight slide 42-43
- (6) TR25 159 R90/C — Clockwise curved segment 44
- (7) TR25 159 R90/A — Anticlockwise curved segment 44
- (8) TNS25 B99 2 x AK — Track system straight slide 42-43
- (9) TR25 255 R180/C — Clockwise curved segment 44
- 1 x BCP25 — Bogie carriage 47
For fixed centre carriage 38-39

HepcoMotion track system straight slides are modified straight slides from Hepco's highly acclaimed GV3 system for which there is a separate catalogue, contact Hepco or visit www.HepcoMotion.com. The slides are manufactured from quality high carbon steel, zone hardened on the V faces for maximum wear resistance and precision ground for high accuracy and conformity. The centre portion of the slide is left soft to allow for customising. Standard lengths are available up to 4020mm (1976mm in the TNMS 12 section) and unlimited lengths can be achieved by butting slides together. Slides are available in stainless steel for applications requiring corrosion resistance. Sets of short slides in incremental lengths can be supplied for customers wishing to extend a system in order to take up chain or belt stretch, see application example 19. For details please visit www.HepcoMotion.com/PRT2datauk and select datasheet No. 10 Slip Block adjustment. A bleed lubrication facility is available to channel lubricant direct to the running surfaces 52.

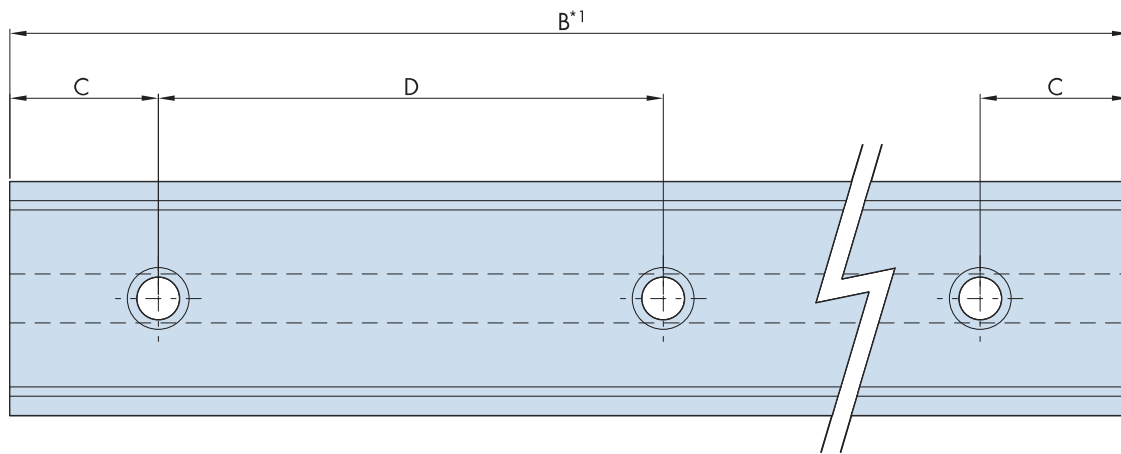

Bleed Lubrication is available as a standard option 52.

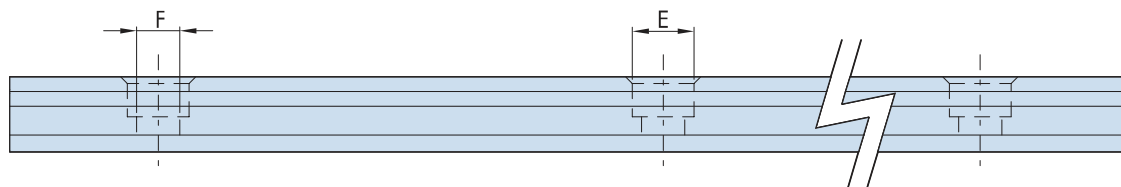
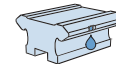

Part Number	A ~	A1 ⁵	B (max)	C <small>0.0 -0.2</small>	D	E Ø x Depth	F	DIN912 (not supplied)	G	H <small>+0.05 0.00</small>	H1	I <small>±0.025</small>	J
TNMS 12	12	12.37	1976	10	45	6 x 3	3.5	M3	3	4	1.8	8.5	1.7
TNV 20	20	20.37	4020	20	90	8 x 4	4.5	M4	4.21	5	2	12	1.75
TNS 25	25	25.74	4020	20	90	10 x 5	5.5	M5	4.71	6	2.5	15	2.6
TNM 44	44	44.74	4020	20	90	11 x 6	7	M6	6.21	8	3	26	2.3
TNL 76	76	76.74	4020	30	180	20 x 12	14	M12	9.21	15	5	50	4.8

Notes:

- Standard slide lengths are available in multiples of hole pitch 'D' + (2 x 'C') up to a maximum length per 'B' dimension in table above. Special length slides can be cut to order.
- Adjustment keys are required at every join between straight slide and curved slide. Please order accordingly (see ordering details). Please note that 'Q' dimension for the TNMS 12 & TNV 20 slides is stepped one end to fit keyway 'H'.
- Please note that dowel pins for the TNMS 12 slide are not stepped.
- Slides in their free unmounted state are not necessarily straight. They should be set to the required straightness when bolting down to the mounting surface at assembly.
- For track system requirements dimensions 'A1' and 'K' will be matched with corresponding dimensions 'F' and 'I', 44.

Track System Double Edge Straight Slides

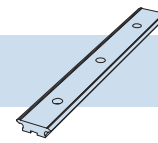

All straight slides within a track system are matched in essential respects both with each other and with their corresponding curved segments. They are ground square on the ends for precision butting and are marked with a reference number and sequence number for identification during installation and for replacement purposes. Opposing slides within a track system are ground to identical lengths. Adjustment keys are available to facilitate alignment with adjacent curved segments. Hepco dowel pins positioned at regular intervals along the slide keyway provide a convenient means of location and alignment. Alternatively, the ground datum faces of the slide may be set against a machined register in the mounting surface*4.

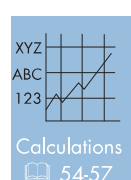
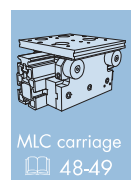
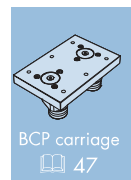
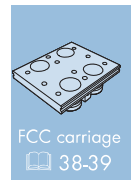

Adjustment Key² (AK)

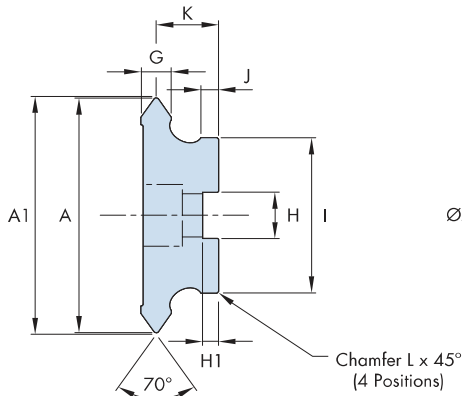
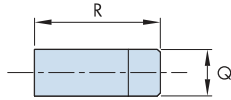

Dowel Pin³ (SDP)

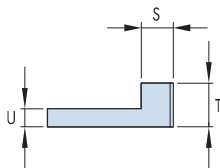
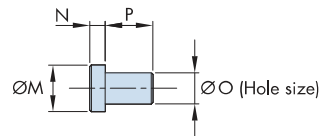

	K ⁵	L	MØ (m6)	N	ØØ (K6)	P	Q	R	S	T	U	~kg/m	Part Number
	6.2	0.2	4 <small>+0.012 +0.004</small>	-	4 <small>+0.002 -0.006</small>	6.75	2	11	4	3	1.5	0.5	TNMS 12
	8	0.3	5 <small>+0.012 +0.004</small>	1.75	4 <small>+0.002 -0.006</small>	6	3.5	20.5	5.5	4	1.7	1.0	TNV 20
	10	0.3	6 <small>+0.012 +0.004</small>	2.25	4 <small>+0.002 -0.006</small>	6	6	22	7	6	2.2	1.5	TNS 25
	12.5	0.3	8 <small>+0.015 +0.006</small>	2.75	6 <small>+0.002 -0.006</small>	8	8	23	8	7	2.7	3.5	TNM 44
	19.5	0.3	15 <small>+0.018 +0.007</small>	4.75	10 <small>+0.002 -0.007</small>	15	15	32	10	11	4.5	10	TNL 76

Ordering details:

Example:

(SS) TNM 44 B1500 (BLP) 2 x AK (16 x SDP)

SS = Stainless Steel option
Leave blank for steel version

Part Number

B (slide length) = 1500mm

SDP = Dowel pin (16-off)
Leave blank if not required

AK = Adjustment key (2-off)

Bleed Lubrication: **BLP** = Plain bore insert 52

BLT = Threaded insert 52
Leave blank if not required

Track System Double Edge Curved Segments



HepcoMotion double edge track system curved segments are cut from stock rings or segments. They are matched in essential respects with their corresponding track system straight slides and ground square on the ends to a specified dimension relative to their true shape. A clearance keyway and tapped hole facility is incorporated each end to provide a method of alignment when assembled together with the mating key of the track system straight slide*1. An additional fixing hole is provided adjacent to the keyway each end to give extra support at the join position for all segments except the TR12 93 & TR12 127. All track system curved segments are marked with a reference number and sequence number 40-41 and are available in stainless steel for applications requiring corrosion resistance. Segments to any number of degrees can be supplied to cater for all track system configurations.

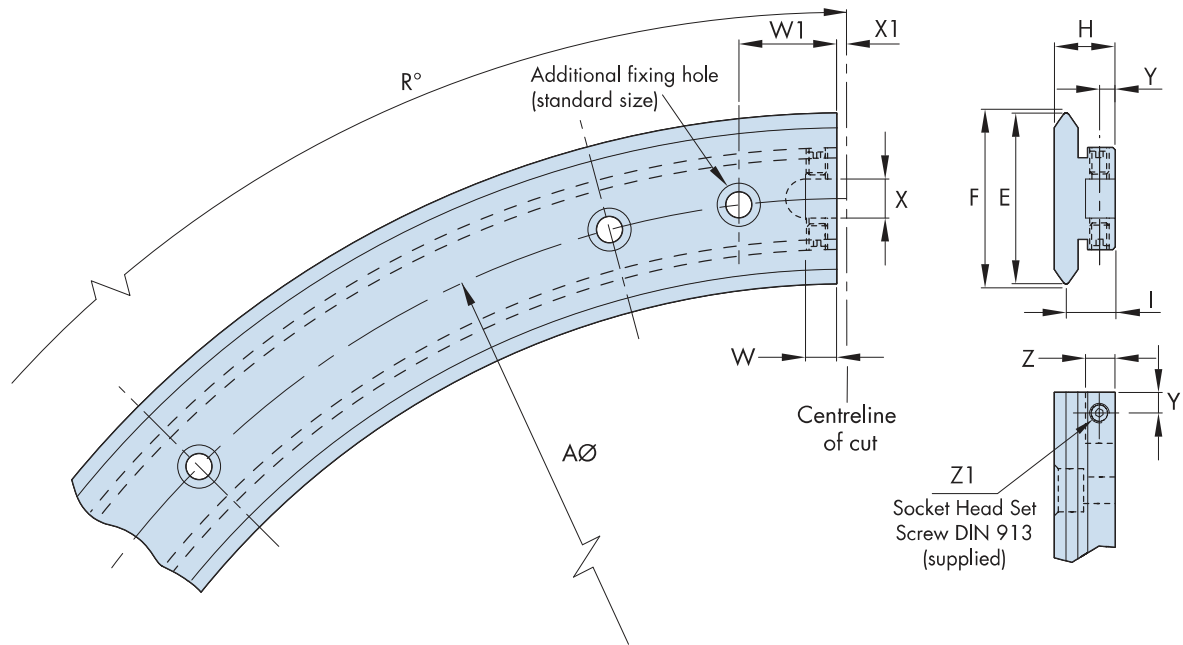

For all other details and dimensions see 26-27

Part Number	A	E	F	H	I ±0.025	R°	W	W1	X	X1 ±0.2	Y	Y1	Z	Z1	
TR12 93	93	12	12.37	7.7	6.2	90	180	4.25	-	2.5	1.5	1.75	2	3.25	M2.5 x 3
TR12 127	127	12	12.37	7.7	6.2	90	180	4.25	-	2.5	1.5	1.75	2	3.25	M2.5 x 3
TR20 143	143	20	20.37	10	8	90	180	6	13	4	1.5	2	3.5	4.5	M3 x 4
TR20 210	210	20	20.37	10	8	90	180	6	15	4	1.5	2	3.5	4.5	M3 x 4
TR25 159	159	25	25.74	12.25	10	90	180	7	18	7	1.5	3	5	6.5	M4 x 4
TR25 255	255	25	25.74	12.25	10	90	180	7	20	7	1.5	3	5	6.5	M4 x 4
TR25 351	351	25	25.74	12.25	10	90	180	7	20	7	1.5	3	5	6.5	M4 x 4
TR44 468	468	44	44.74	15.5	12.5	90	180	8	25	10	2.5	4	6	7.5	M5 x 6
TR44 612	612	44	44.74	15.5	12.5	90	180	8	25	10	2.5	4	6	7.5	M5 x 6
TR76 799	799	76	76.74	24	19.5	90	180	10	30	18	2.5	6	7	11.5	M8 x 16
TR76 1033	1033	76	76.74	24	19.5	90	180	10	30	18	2.5	6	7	11.5	M8 x 16
TR76 1267	1267	76	76.74	24	19.5	90	180	10	30	18	2.5	6	7	11.5	M8 x 16
TR76 1501	1501	76	76.74	24	19.5	90	180	10	30	18	2.5	6	7	11.5	M8 x 16

Notes:

- Some distortion may be present in segments in their free unmounted state. This may be overcome by bolting to the mounting surface and setting to adjacent slides using the keyway alignment facility 41. True Shape segments are available on request. Please visit www.HepcoMotion.com/PRTdatauk and select datasheet No.9 True Shape Rings & Segments.

Ordering details:

Example:

SS = Stainless Steel option
Leave blank for steel version

Part Number

(SS) TR44 612 R90 (N)

N = Tapped hole option, 26-27
Leave blank if not required

R90 = 90° segment

R180 = 180° segment



HepcoMotion track system single edge straight slides retain key features of the double edge slides, with precision ground finish and zone hardened V faces 42 & 43. Standard lengths are available up to 4020mm and unlimited lengths can be achieved by butting slides together. Slides are matched in essential respects both with each other and with their corresponding curved segments. They are ground square on the ends for precision butting and are marked with a reference number and sequence number for identification during installation and for replacement purposes 40 & 41. Slide pairs and opposing slides within a track system are ground to identical lengths

Track system single edge slides, can be used to construct a single edge duplex track system which provides a wide platform for supporting large components with extreme rigidity 17. The large rear face of the single edge slide enables a full width rack to be machined in the rear face providing for a strong drive. This can be used for the construction of a gear driven duplex track system 18.

Please visit www.HepcoMotion.com/PRT2datauk and select datasheet No. 4 Single Edge track systems.

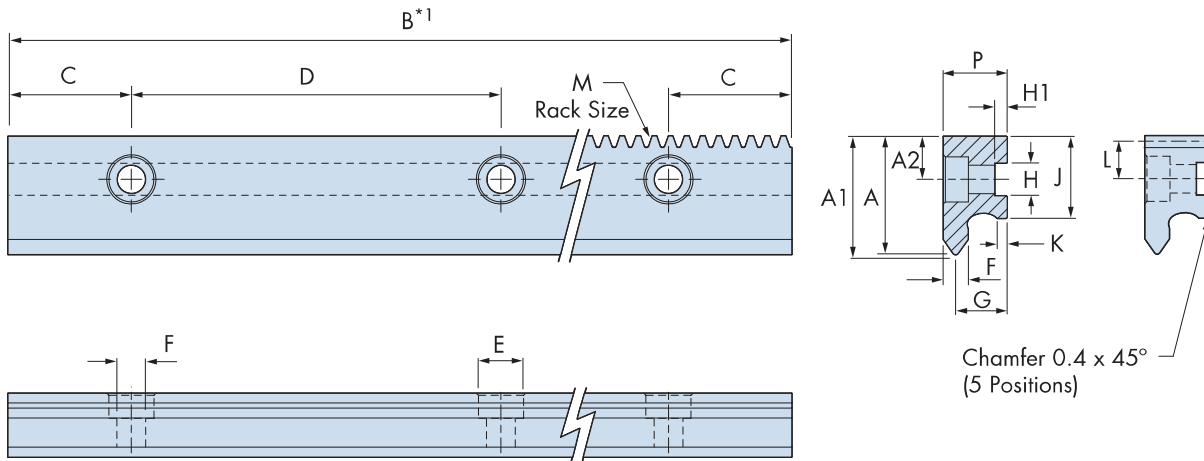

Dowel Pin (SDP)
For details 42 - 43

Part Number	For use with	A	A1*3	A2	C	D	E	F	G*3	H	H1	J	K	L	M*4	P	kg/m
		~				±0.2	Ø x Depth			+0.05 -0.00		±0.025			Module		
TNSE	TRIS278, TRES376	21	21.37	8.5	20	90	10 x 5.1	5.5	10	6	2.5	16	2.6	7.4	1	12.35	1.6
TNME	TRIM482, TREM655	29	29.37	10.5	20	90	11 x 6.1	7	12.5	8	3	20	2.3	9.25	1.25	15.6	2.6

Notes:

- Standard slide lengths are available in multiples of hole pitch 'D' + (2 x 'C') up to a 4020mm maximum length. Special length slides can be cut to order.
- Slides in their free unmounted state are not necessarily straight. They should be set to the required straightness when bolting down to the mounting surface at assembly.
- For track system requirements dimensions 'A1' and 'G' will be matched with corresponding dimensions 'F' and 'I', 46.
- Single edge slides with a rack, will be supplied in lengths that correspond to multiples of rack pitch. The position of the ends of the slides is accurately controlled to coincide with the centre of the rack root to give perfect running joints for slides and ring segments.

Ordering details:

Example: **TNME B1500 (R) (BL) (16 x SDP)**

Part Number **TNME** **B1500** **(R)** **(BL)** **(16 x SDP)** **SDP = Dowel pin (16-off)**
 Leave blank if not required

B (slide length) = 1500mm **BLP = Plain bore insert** 52
 Leave blank if not required

R = Rack cut Slide **BLT = Threaded insert** 52
 Leave blank if not required

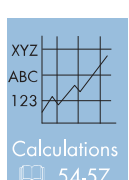
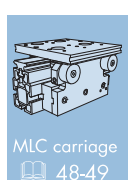
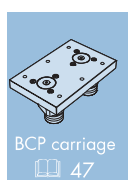
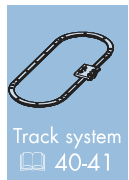
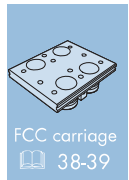

HepcoMotion track system single edge curved segments are used in single edge duplex track systems 17, 18 & 41. Segments TRIS278 & TRES376 combine with TNSE track system single edges slides, and segments TRIM482 & TREM655 combine with TNME slides.

These segments are made to True Shape specification (please visit www.HepcoMotion.com/PRT2datauk and select datasheet No. 9 True Shape Rings & Segments). All segment pairs in a system are matched in essential respects with each other and with their corresponding straight slides. Ends are ground square to a specific dimension. An additional fixing hole is provided at each end of the segment to give extra support at the join position. It is recommended that all single edge track system components are aligned to a machined register. Hepco will supply suitable machined plates with precision registers, on request, Please see datasheet for design criteria.

Segments are available gear cut, for mating with rack cut straight slides, to produce a gear driven track system. For more details, and for information regarding assembly, please visit www.HepcoMotion.com/PRT2datauk and select datasheet No. 4 Single Edge Track Systems.

All track system single edge curved segments are marked with a reference and sequence number for identification and replacement purposes 40 & 41. Segments of any angle can be supplied to cater for all track system configurations.

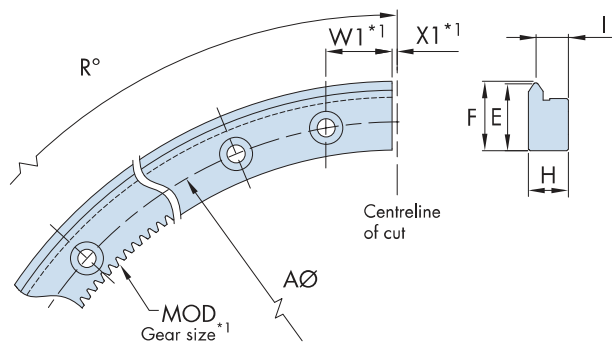

External Single Edge Track Segment - TRE

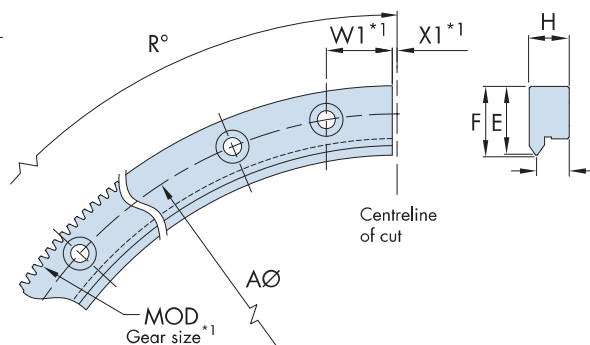

Internal Single Edge Track Segment - TRI

For all other details and dimensions see 28-31

Part Number	For use with	A	E	F	H	I ±0.025	R°	W1	X1 ±0.1	MOD*1	
TRIS 278	TNSE	261	20.8	21.37	12.25	10	90	180	20	1.5	1
TRES 376	TNSE	351	20.8	21.37	12.25	10	90	180	20	1.5	1
TRIM 482	TNME	461.5	28.8	29.37	15.5	12.5	90	180	25	2.5	1.25
TREM 655	TNME	618.5	28.8	29.37	15.5	12.5	90	180	25	2.5	1.25

Notes:

- Track system single edge segments with gear drive option Q or P will be ended to the root of a gear tooth. This will affect dimensions W1 and X1. For more details, please visit www.HepcoMotion.com/PRT2datauk and select datasheet No. 4 Single Edge track systems.

Ordering details:

Example: **TRES 376 R90 (Q) (N)**

Part Number **TRES 376** **R90** **(Q)** **(N)**

R90 = 90° segment

R180 = 180° segment

N = Tapped hole option, 28-31

Q = Internal gear drive option
Available on TRE option only

P = External gear drive option
Available on TRI option only

Bogie Carriage

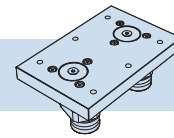

The HepcoMotion Bogie Carriage is designed for use with tracks where "S" bends or bends of differing radii are to be negotiated. Each bogie swivels on a special play free axial/radial ball bearing which is lubricated for life. This enables the bogie carriage to follow exactly the path of the track at all times. Carriage plates and bogie swivel plates are made from high strength aluminium alloy and finished anodised. Bogie carriages are supplied assembled and adjusted to suit the accompanying track system*¹. Customers are advised to specify the HepcoMotion bleed lubrication facility within the track 52 as lubricators cannot be fitted to bogie carriages. Special size carriage plates are available on request.

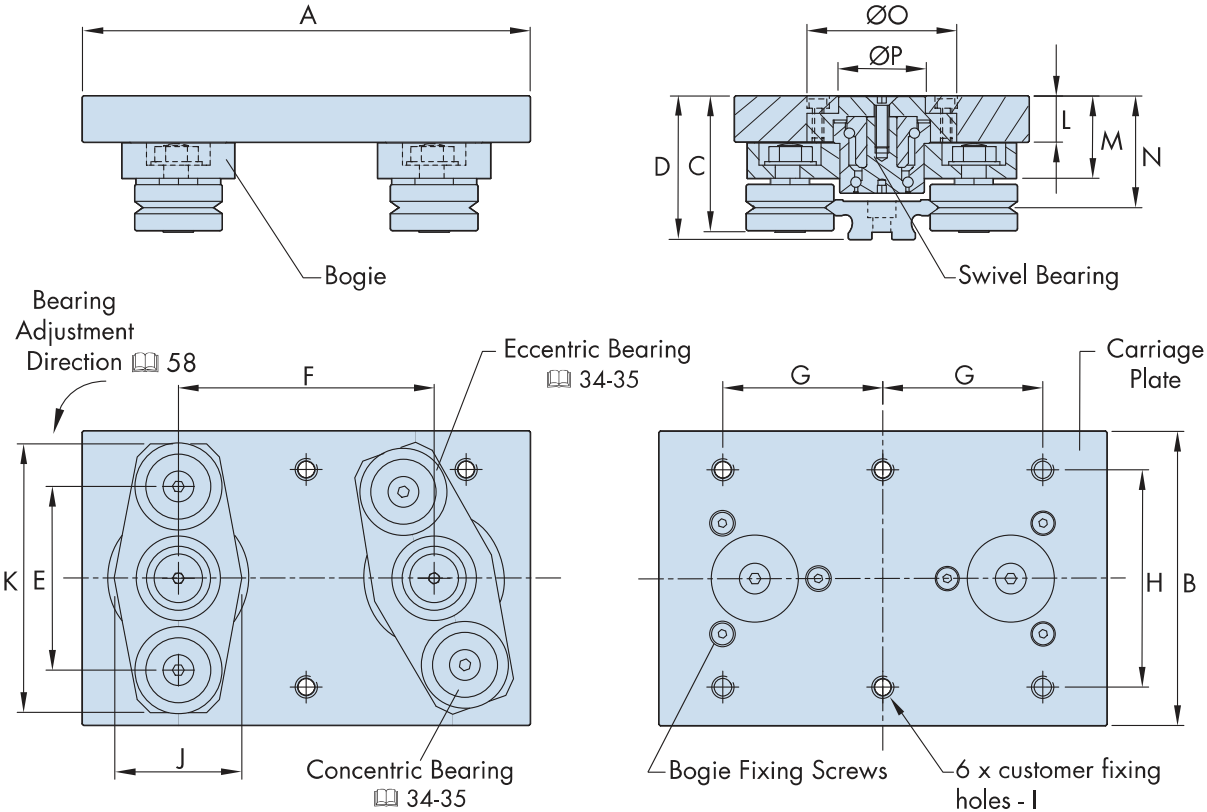



Part Number	For use with	A	B	C	D	E	F	G ±0.1	H ±0.1	I	J	K	L	M	N	ØO	ØP	Adjustment brace	~kg
BCP 25	TR 25	130	80	42.1	44.5	46.1	75	45	60	M6	38	75	15	25.5	34.5	46	29	AB-25	**
BCP 44	TR 44	175	115	53.8	56.5	71.9	100	62.5	85	M8	53	105	18	32.5	44	59	34	AB-44	**
BCP 76	TR 76	240	185	77.2	81	118.7	130	87.5	125	M10	72	170	24	42.5	61.5	100	70	AB-76	**

Notes:

- In rare cases where adjustment of the eccentric bearings is required, the bogies must be removed from the carriage plate and bolted instead to the adjustment brace. This will mimic the carriage and provide access to the fixing nuts allowing adjustment of the eccentric bearings to take place.
- Please note that floating bearings 36 cannot be supplied with bogie bearings.

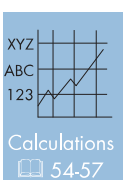
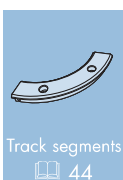
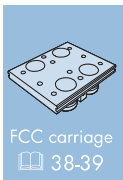
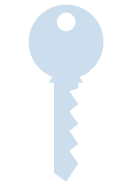
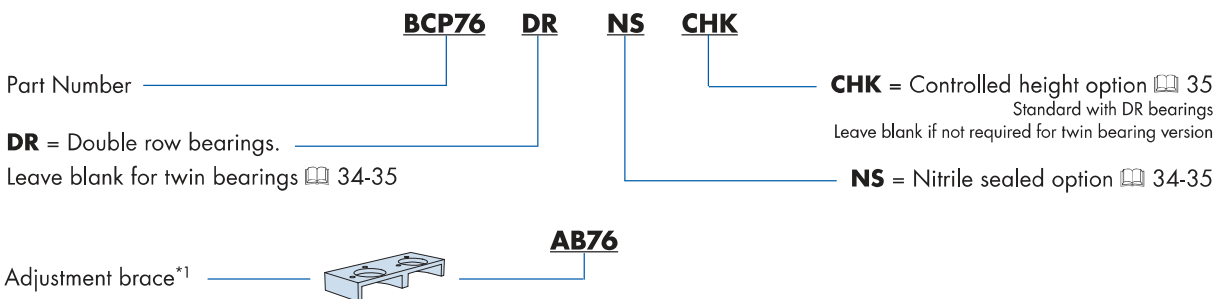
Ordering details:



HepcoMotion moment load carriage systems provide extra support and rigidity in applications where high downwards or offset loads are anticipated, typically at work stations. It is also possible to arrange for continuous support of the carriages all around the circuit. Moment load carriages are a variation of the standard fixed centre carriages  38-39 and are available in all 25 and 44 equivalent sizes. Carriages can be ordered complete with the carriage locking system and with either the fixed latch or trip latch belt connection facility.

Please visit www.HepcoMotion.com/PRT2datauk and select datasheet No. 5 Moment Load carriage systems for more details. For other compatible driven system components in main illustrations below see  50-51.

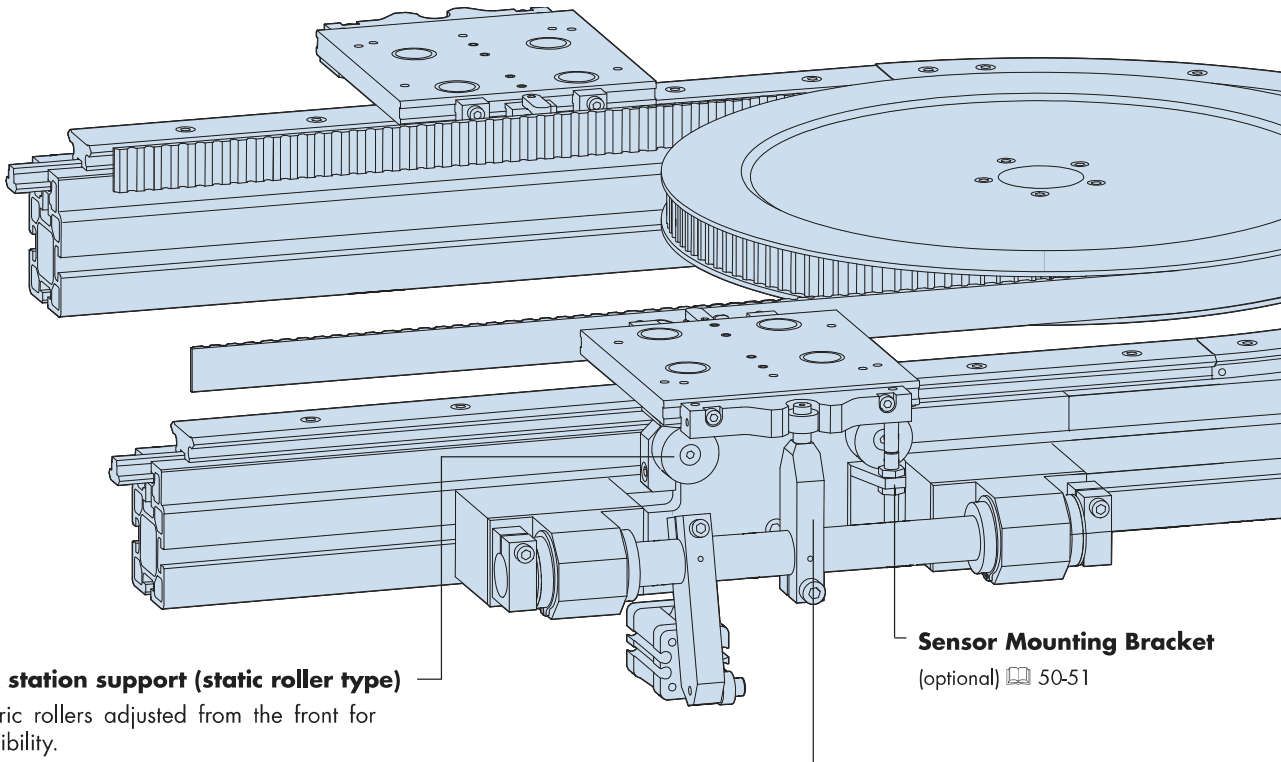

Work station support (static roller type)

Eccentric rollers adjusted from the front for accessibility.

Sensor Mounting Bracket

(optional)  50-51

Carriage Locking System

(optional)  50-51

Moment Load Carriage (dynamic roller type)

For single roller or twin rollers .

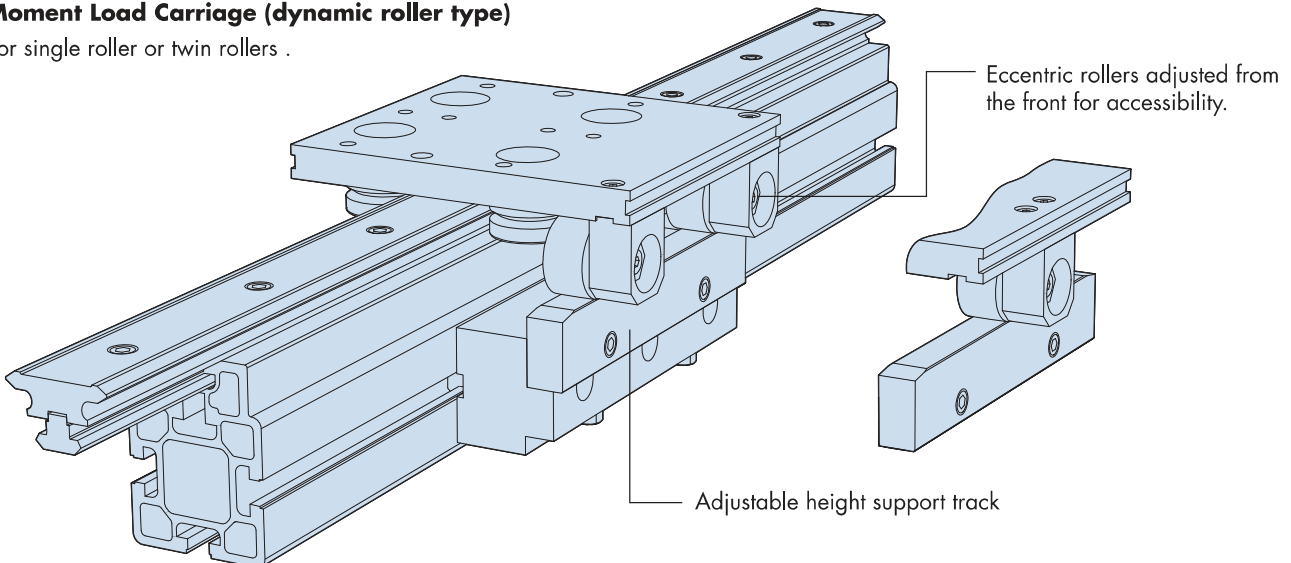

Eccentric rollers adjusted from the front for accessibility.

Adjustable height support track

Moment Load Carriage Systems

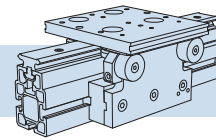

Moment load carriage systems are available with two types of work station support, both designed to connect to the track system support beam:

Static roller type: with eccentrically adjusted rollers attached to the framework bearing against a fixed skid plate on the underside of the carriage. This reduces the total number of rollers required and therefore the cost of a system with many carriages but few work stations.

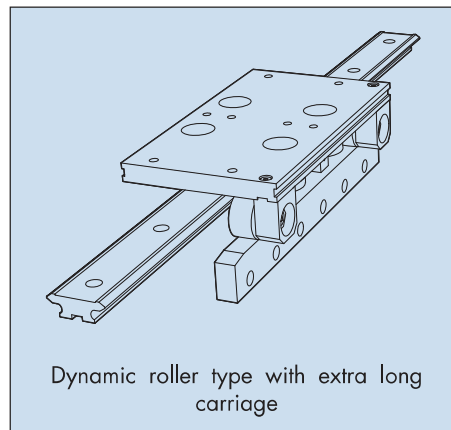
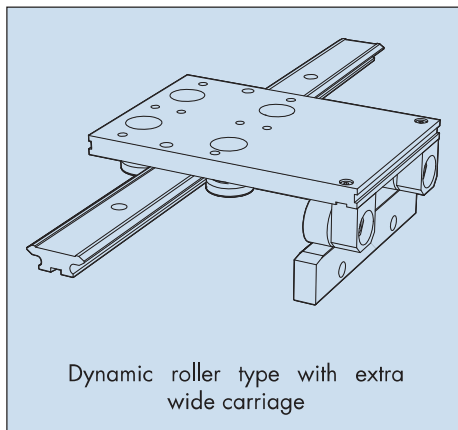
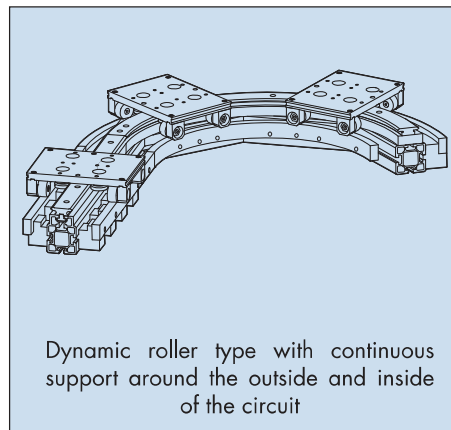
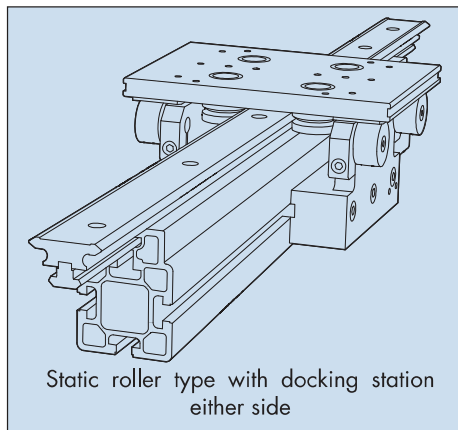
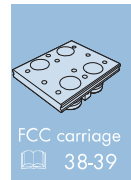
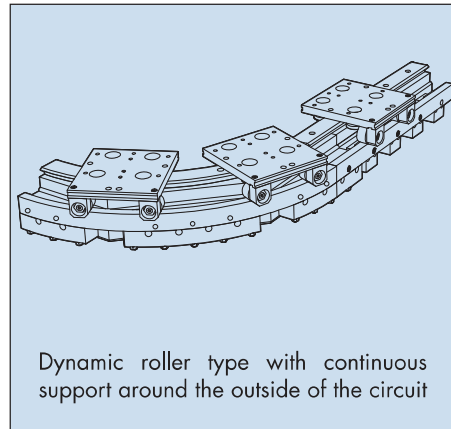
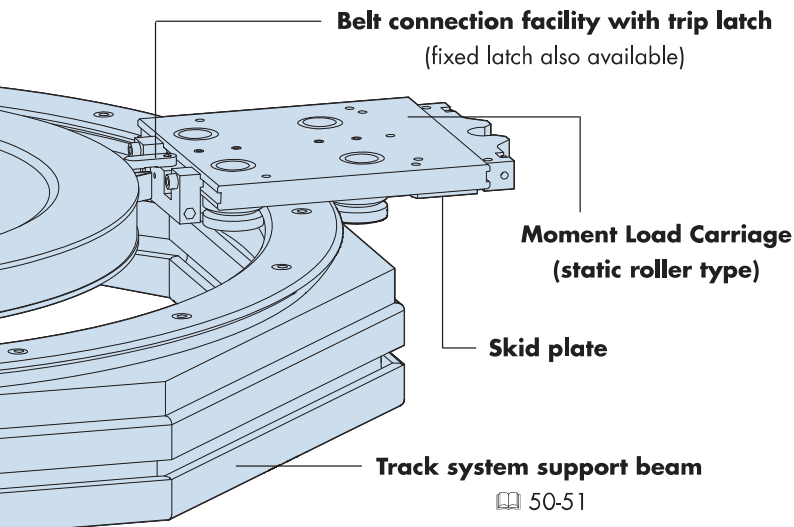

Dynamic roller type: with eccentrically adjusted rollers attached to the underside of the carriage, bearing on adjustable height support track. The combination of these adjustable features facilitates set up where accuracy and alignment cannot be guaranteed or where continuous support for the carriage is required all around the circuit.

Standard components, shown in the unframed illustrations, can also be used within customers special designs a number of which are shown in the framed illustrations. Special size carriages can be easily supplied.



HepcoMotion supply a comprehensive range of components and assemblies to enable the 25-351 and 44-612 size track systems to be incorporated into customers own designs complete with drive facility. Many of the components shown below can be also be used for other sizes of track system. The components are well proven having been used for many years in the HepcoMotion DTS, a complete ready to use Driven Track System highly recommended for customers able to use this fully assembled standard product.

Carriages

Fixed centre type  38-39, can be supplied with belt connection facility or carriage locking cam as shown,  48-49 for moment load version.

Trip Latch assembly

Transmits the drive from the belt to the carriages and can be set to trip out of engagement at any force up to 60N.
- Fixed latches can also be supplied.

Track sizes available:

25mm wide slides with 351mm \varnothing ring segments or 44mm wide slides with 612mm \varnothing ring segments. See  42-44

Carriage Locking System

For intermittent motion systems, locks carriages in position to a repeatable accuracy of $\pm 0.05\text{mm}$ - Adjustable locking position - Multiple locking devices can be operated by one actuator.

Sensor Mounting Bracket

To suit M8 threaded proximity switch
- Detects carriage position for control and safety purposes.

Bearing Cartridge

Able to withstand high tension forces of the belt - Caters for belt adjustment - Idler type or, extended shaft type available for attaching the drive - Sealed bearings lubricated for life.

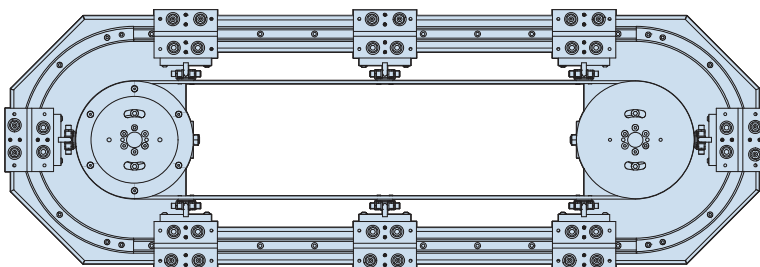

Oval path driven track system

Driven Track System Components

Moment load carriage systems 48-49 are also compatible with the DTS which is the full system as illustrated below and is comprehensively detailed in a separate catalogue. Please contact Hepco or visit www.HepcoMotion.com.

For all details of Driven Track System components please visit www.HepcoMotion.com/PRT2datauk and select datasheet No. 8

Pulley

Toothed version for driving or plain version for idling - Fits to Hepco bearing cartridge.

Timing Belt

High tensile 10mm pitch belt fitted with lugs at desired spacing for transmitting drive to the carriages - Lugs securely fixed through to opposite side of belt.

Slide attachment profile

Precision aluminium T profile provides strong and convenient method of attaching and locating slides with no loss of position when slides are disassembled - Long lengths available.

Track system support beam

Precision aluminium profile provides a rigid chassis for the system - Centre T slot provided for attaching slides - Can be machined away to expose secondary T slot for end plate fixing - Other T slots enable ancillary equipment to be attached - Compatible with HepcoMotion MCS aluminium frame system which enables full supporting structure to be constructed. Refer to separate MCS catalogue www.HepcoMotion.com/MCSdatauk.

End Plates

Top plate supports the bearing cartridge and connects to the track system support beams providing continuity of support for the ring slide segment - Bottom plate braces between track system support beams.

Rectangular path driven track system

