

NOW AVAILABLE...
EXTENDED RANGE OF JOURNALS
BEARINGS FOR HIGH TEMPERATURE
AND VACUUM APPLICATIONS
ask for details

HepcoMotion®

SL2

stainless steel based
slide system

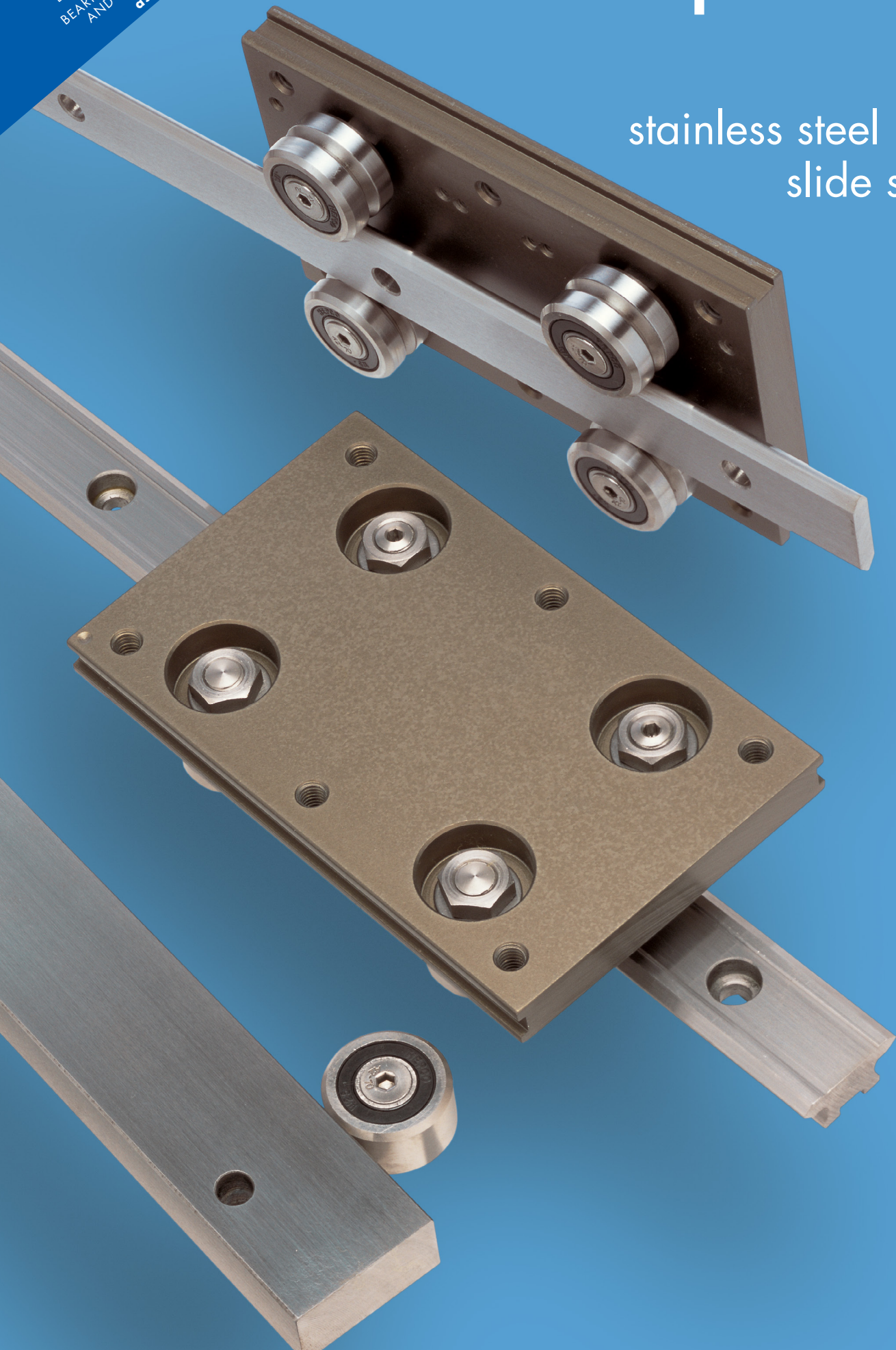

Contents	Page
Introduction	1
System Composition	2-3
Application Examples	4-5
Data and Dimensions	
Assembled Systems	6-9
Stainless Steel Slides	10-11
Stainless Steel Bearing Assemblies	12-13
Aluminium Carriage Plates	14-15
Cap Seals and Lubricators	16
Flange Clamps	17
Technical Data	
Load/Life Calculations and Examples	18-19
System Assembly and Adjustment	20-21
Deflection of Self-Supporting Slides	22
Technical Specifications	23

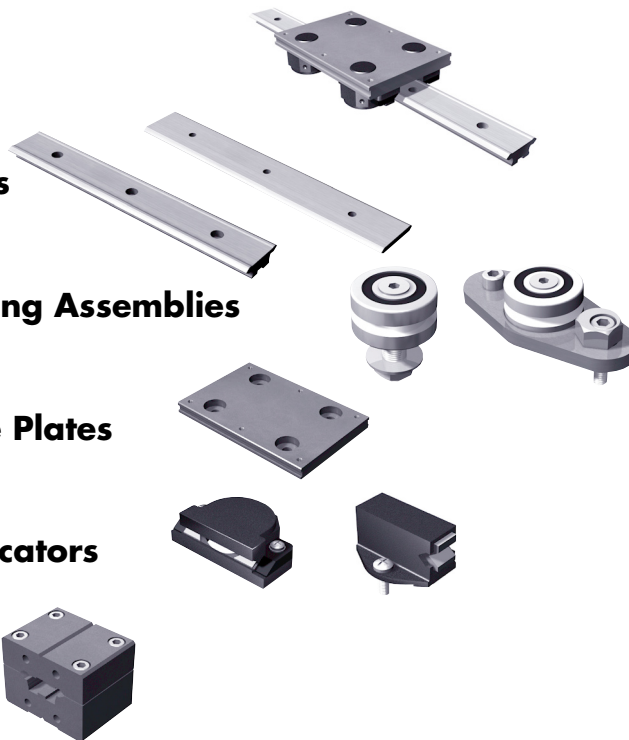

Introducing the HepcoMotion® SL2 Stainless Steel Based Slide System

Based on the proven Generation II range, Hepco's SL2 System offers the user basic interchangeability with Gen II and GV3 components in an extensive linear range consisting of stainless steel Bearing Assemblies, Flat Slides and Spacer Slides. A complementary range of lightweight aluminium Carriage Plates and Flange Clamps is also available, with special surface treatment providing corrosion resistance better than most stainless steels.

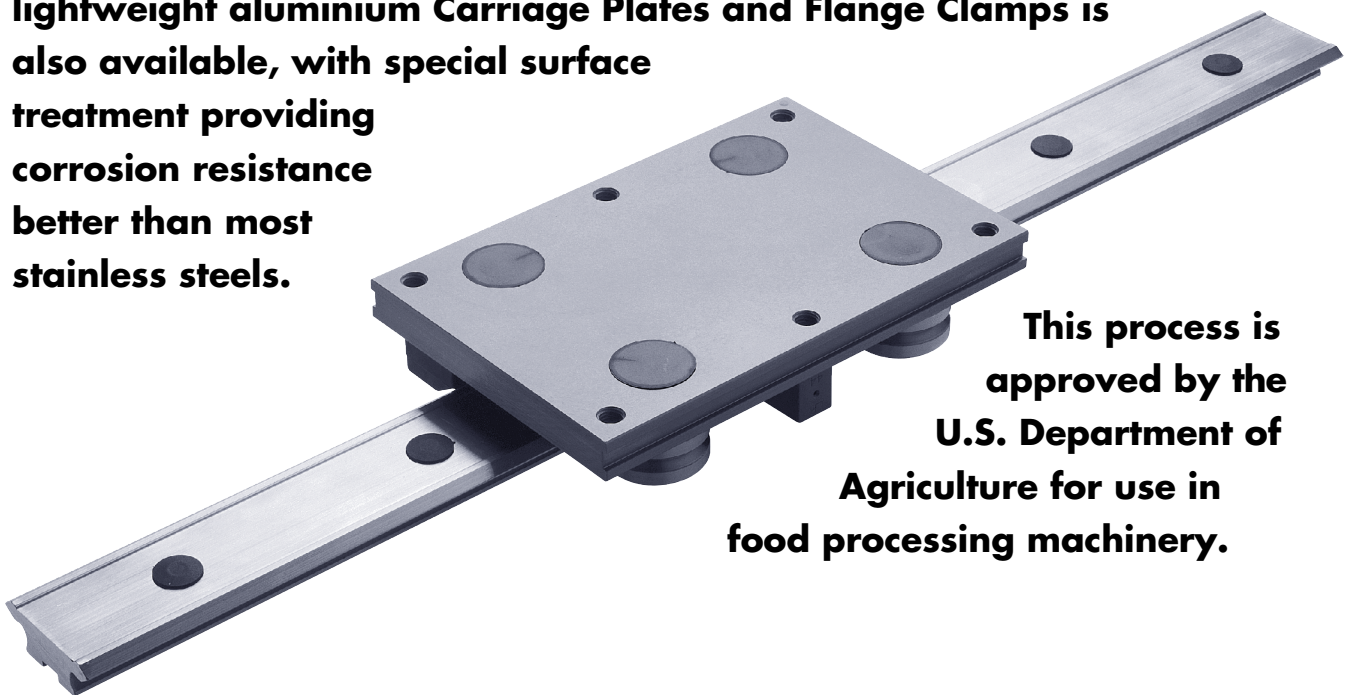

This process is approved by the U.S. Department of Agriculture for use in food processing machinery.

Features and Benefits

- Hardened and ground Slides for durability, resistance to corrosion and smooth running.
- Long lengths available up to 4m in most sections, saves on assembly time.
- Extensive range of Spacer or Flat Slides gives many design options.
- Proven Hepco 'V' concept for low friction and good rigidity.
- Cap Seals prevent ingress of dirt and offer positive lubrication, long life, and improved safety.
- Lubricators offer positive lubrication with improved life and low friction.
- Suitable for many clean room applications.
- Three lengths of Carriage Plate available for each Slide section gives many design options.
- Double Row Bearing Assembly option for high radial loads and long life, ideal for dirty applications.
- Twin Bearing Assembly option gives low friction and is tolerant of misalignment.
- Low friction characteristics allow system to operate 'dry' with no lubrication.
- Available as assembled unit or in component form for maximum flexibility.
- Extensive use of plastic plugs eliminates dirt traps.
- Maintenance-free, therefore can perform in arduous conditions.

System Composition

SL2 offers excellent performance through a quality manufacturing process and careful selection of materials, and has been designed to provide the ideal combination of corrosion resistance and long service life even in the most arduous application.

The **SL2** range of **Slides** is very extensive, comprising seven **Flat Slide** sections and four **Spacer Slide** sections. This very wide range ensures that the most suitable **Slide** can always be specified for any application. All except the smallest are available in 4 metre lengths, ground on all main surfaces with hardened 'V' running faces.

SL2 Carriages are available in three standard lengths as fully assembled units, factory adjusted to the **Slide** of your choice. The system makes extensive use of plastic sealing plugs to close off counterbores, thus avoiding the possibility of dirt traps. **SL2** is therefore ideally suited for food processing and clean room applications.

BLIND HOLE FIXING BEARING ASSEMBLY CONCENTRIC ■ & ECCENTRIC ★

- ★ For use where access to opposite side of the mounting plate is restricted.
- ★ Easy fixing from one side only.
- ★ Twin type or Double Row Bearing Assemblies available (see opposite).
- ★ Controlled height option improves system height accuracy
 - ★ Low ratio adjustment for controlled setting.
 - Defines the datum position for the system.

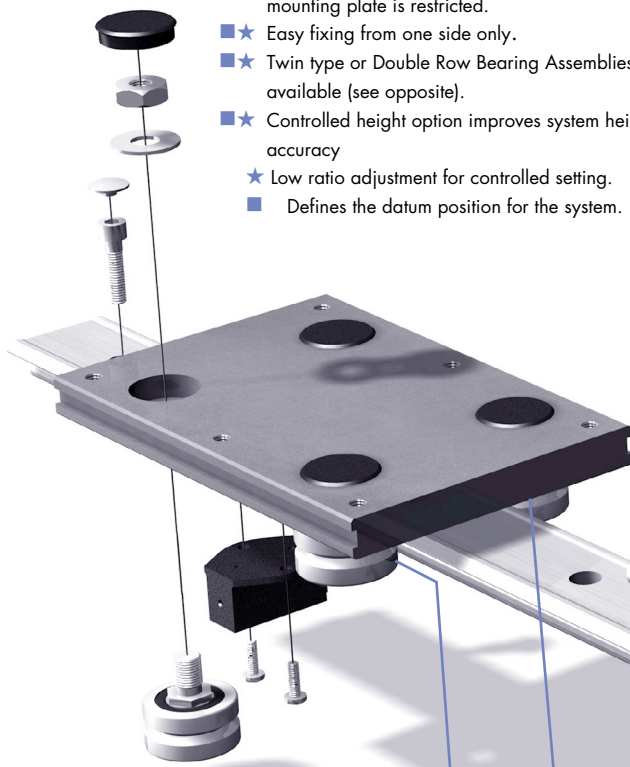

THROUGH HOLE FIXING BEARING ASSEMBLY CONCENTRIC ★ & ECCENTRIC ■

- ★ ■ For use in mounting plates of limited thickness where there is unrestricted access to the opposite side.
- ★ ■ Two stud lengths available to suit most mounting plate thicknesses.
- ★ ■ Twin or Double Row types available (see opposite).
- ★ Controlled height option improves system height accuracy
 - ★ Defines the datum position for the system.
 - Easily adjusted via hexagon flange or socket in stud.

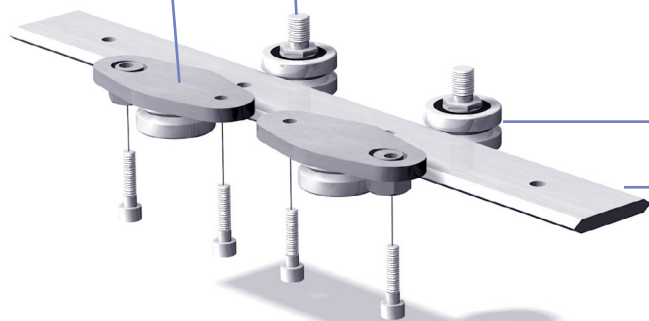

STAINLESS STEEL SLIDE SPACER TYPE ■ & FLAT TYPE ★

- ★ Hardened 'V' faces for long life.
- ★ Centre section unhardened for drilling or machining.
- ★ Length cut to your requirements, up to 4m in one piece.
- Mounts directly to machine. No special construction or additional components required.
- Keyway and datum faces for easy alignment.
- Available without holes for use with Flange Clamps or for customising.
- Plastic caps for fixing screws to seal off counterbores.
- ★ Useful where weight saving and minimum inertia are important.
- ★ Extra Slide width options.

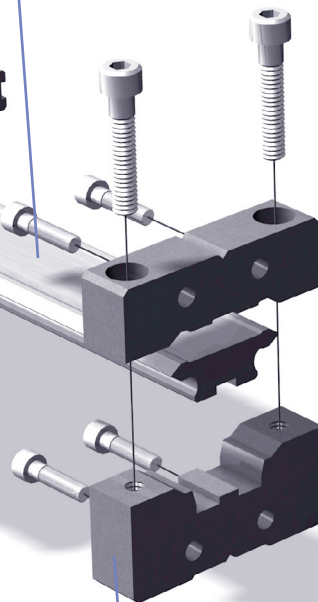

FLANGE CLAMPS

- Enables Slide to become a self-supporting beam.
- Two mounting possibilities - face fixing or base fixing.
- Available in long or short type, to support a Slide at one end or both ends.
- High strength aluminium, with corrosion resistant coating approved by U.S. Dept. of Agriculture.

System Composition

Carriages can be supplied by Hepco fitted with:

- BEARING ASSEMBLIES ONLY** - for dry or minimum friction applications.
- CAP SEALS** - to shroud the Bearing Assemblies - for excellent lubrication and sealing quality.
- LUBRICATORS** - for the application of lubricant with lower friction.

All components are available individually for customers who wish to construct their own **Carriage Plates**, or where the **Carriage** may be part of the machine structure. All **Bearing Assemblies** are of stainless steel construction, in either Twin Bearing or Double Row format, and are supplied lubricated for life. They are hardened and precision ground to special tolerances and raceway conformity to suit **Slide System** applications.

STAINLESS STEEL TWIN OR DOUBLE ROW BEARING OPTION ACROSS RANGE*

- **Twin type Bearing Assemblies** provide slight compliance offering accurate, play-free motion and tolerance of misalignment. Frictional resistance can be varied, useful where very low friction is required. Economical, and easy to adjust.
- **Double Row Bearing Assemblies** have higher radial load capacity. They are more suited to harsh environments and high speed conditions where extra long life is required. One piece construction avoids dirt traps.

*All except smallest size

LUBRICATOR (OPTIONAL)

- Use with short Carriage Plate/Miniature System or as an option to Cap Seals on longer Carriage Plates.
- Provides lower friction running with long system life.
- Applies very small quantities of oil, for long system life.
- Supplied charged with mineral oil as standard, or dry on request (for other oil types).

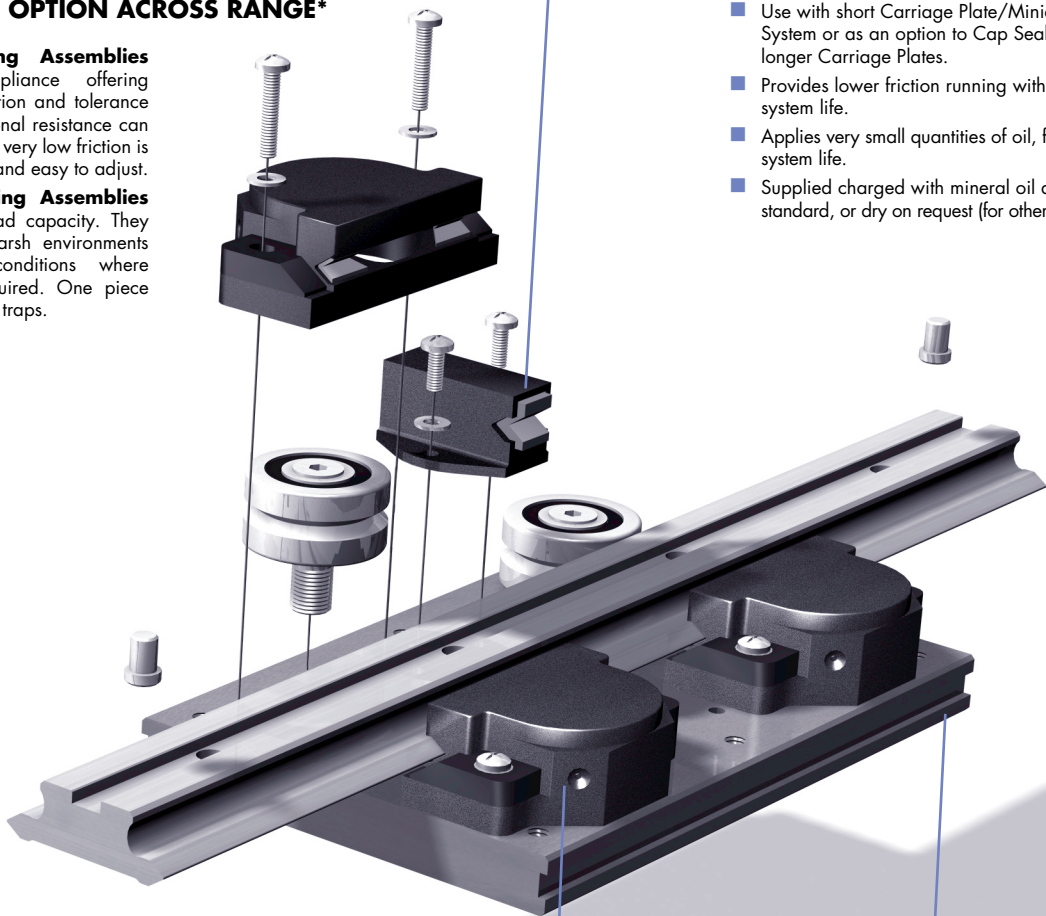

CAP SEAL (OPTIONAL)

- Lubricates contact surfaces from a grease reservoir, giving extended re-lubrication interval and long system life.
- Totally encloses the Bearing Assembly.
- Increases load capacity.
- Extends system life.
- Excludes debris.
- Improves operational safety.
- Can be used on medium and long Carriage lengths (on all but miniature systems).

CARRIAGE PLATE

- High strength, lightweight aluminium alloy with corrosion resistant coating approved by the U.S. Dept. of Agriculture.
- Large mounting area with flush surface.
- Three standard lengths in each size.
- Pre-drilled & tapped component mounting holes.
- Counterbores sealed with plastic plugs to eliminate dirt traps.
- Recess both sides to facilitate location of switch cams and other components.
- Stainless steel Carriage Plates available on request (to customers' drawings).

Application Examples

Industrial Applications

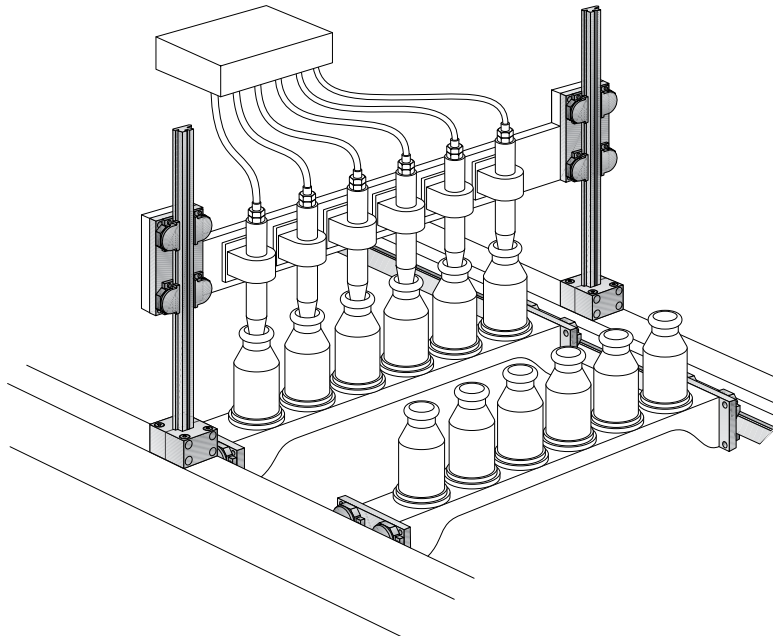

SL2 System is used for vertical and horizontal guidance on a bottle filling machine in the cosmetics industry.

Spacer Slides are shown fixed to the machine structure on the horizontal axis. Short undrilled **Spacer Slides** are used on the vertical axis supported one end only by long type **Flange Clamps**. Hepco **Carriage Plates** are shown used throughout. Alternatively, **Bearing Assemblies** and **Cap Seals** can be mounted direct to the moving components of the machine. Care should be taken to ensure parallelism of opposing **Slides** during installation. Twin type **Bearing Assemblies** can be used throughout in cases where there may be slight misalignment of opposing **Slides**.

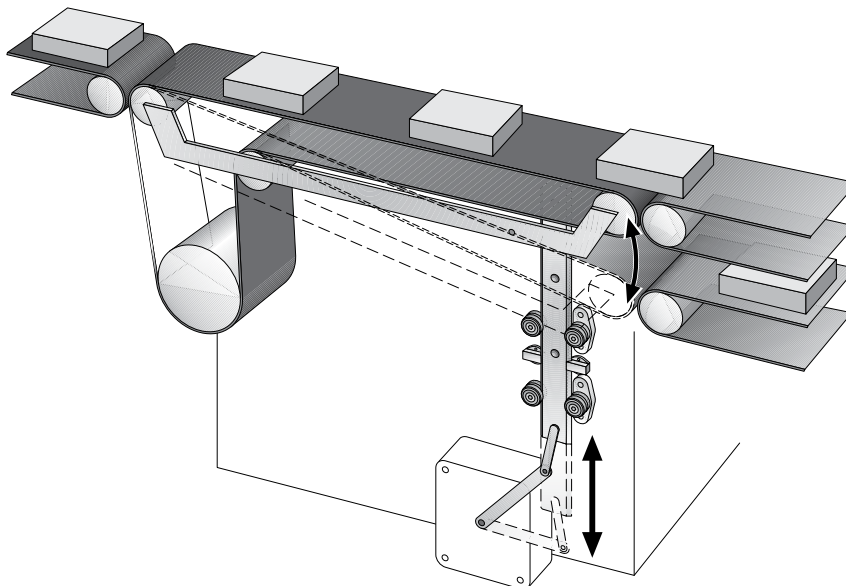

SL2 System is used as the vertical guidance in a food industry application to move a diverting conveyor between two further conveyors alternately. High speed and high duty operation driven by a crank arm.

The **SL2 Flat Slide** has been chosen as the moving element in order to reduce mass. Blind Hole type **Bearing Assemblies** have been used due to the thickness of the mounting plate being too great to accommodate the stud and nut of the Through Fixing type.

The system is lubricated by means of Hepco **Lubricators**, since **Cap Seals** cannot be used with the Blind Hole eccentric type **Bearing Assemblies**. Lubricated systems allow much greater life for any given load (see Load/Life section).

Application Examples

Scientific/Test Applications

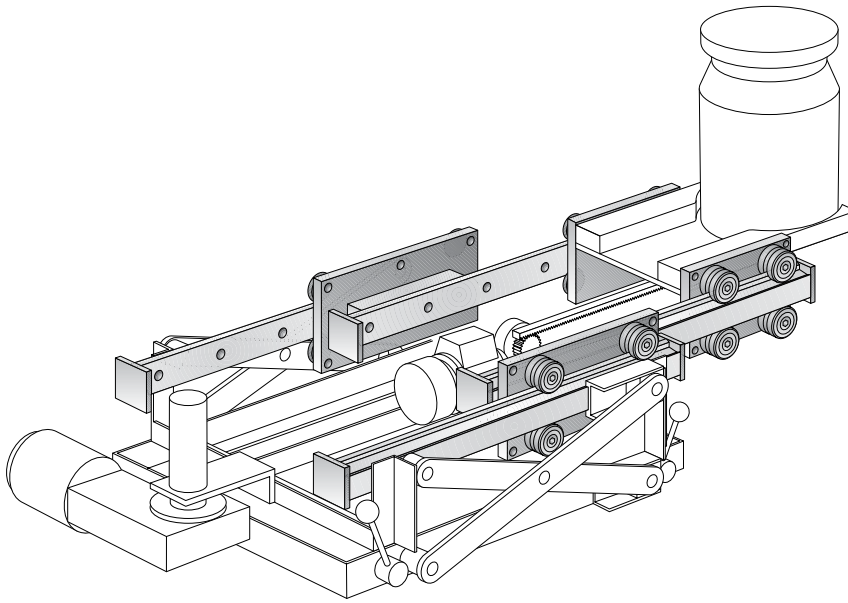

SL2 System is used for telescopic horizontal guidance in a Nuclear Industry drum handling application. Vertical movement is provided by a scissor lift.

The environment experiences a low level of radiation, therefore the **Bearing Assemblies** are supplied with special grease lubrication internally. The system is required to be all stainless steel, therefore the standard coated aluminium **Carriage Plates** have been replaced by specials, manufactured by Hepco to the customer's drawings. External lubrication of the **Slides** is not possible in this application, however, the low friction characteristics of Hepco systems means that 'dry' running is not a problem.

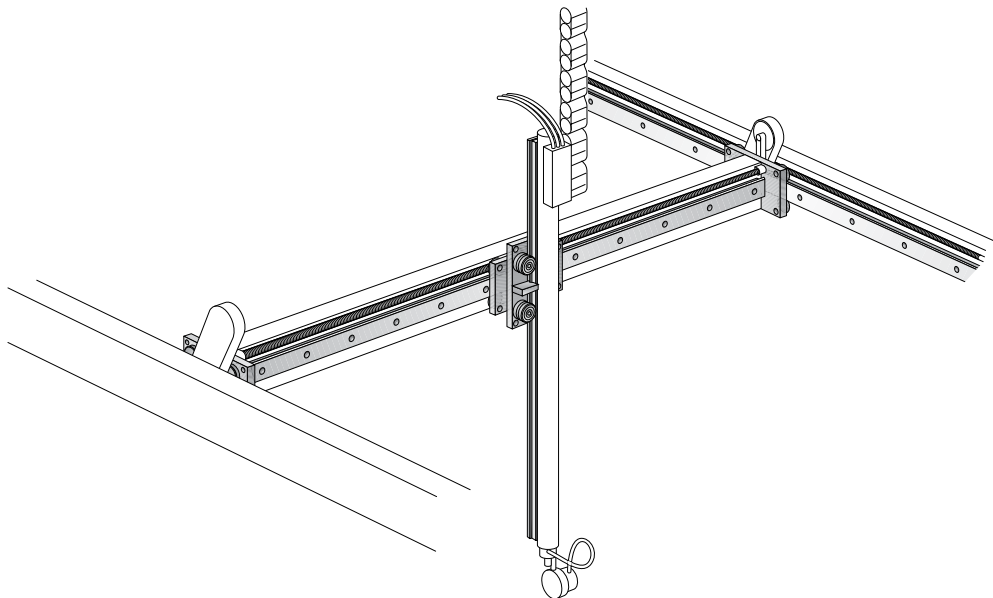

SL2 System is used as the means of guidance for all axes of a non-destructive ultrasonic testing machine. An ultrasonic probe is lowered into a spray tank during research in a university engineering department. For vertical guidance a special curved section stainless steel backplate manufactured by Hepco to the customer's drawing is incorporated, allowing an **SL2 Flat Slide** to be mounted to the circular section probe. The **SL2 System** is ideally suited to this humid environment.

The use of Twin type **Bearing Assemblies** offers extra compliance to compensate for slight deviations of the opposing **Slides** on the horizontal axis. **Lubricators** give increased system life whilst retaining low friction. The zero play which is characteristic of the Hepco system ensures rigidity at the probe end, despite the large overhang in this application.

Assembled Systems

SL2 can be ordered as individual components or as a Factory Assembled System. Ready-assembled Carriages are available with just the Bearing Assemblies fitted, or with the addition of either Cap Seals or Lubricators. Assembled carriages can also be ordered in a controlled height version (CHK) which minimises variation in the AA dimension*5. This is desirable in high precision applications. (see Stock SL2 Carriage table page 9). The following three pages show important reference dimensions between assembled components, as well as the maximum overall sizes of the assemblies. Other dimensions will be found on the pages relating to the specific components (10 - 17).

Assembled Systems Incorporating Carriage Plates, Through Hole Fixing Bearing Assemblies and Cap Seals

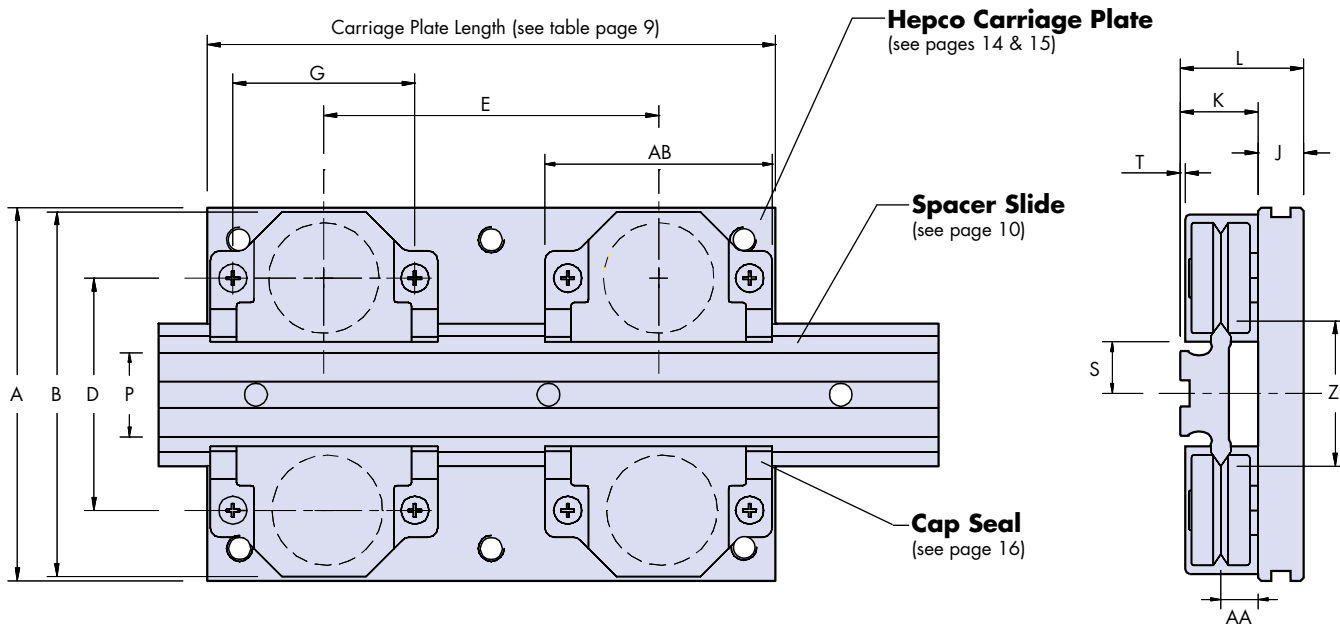

Slide Section <small>see note 1</small>	Z Size ~	Bearing Assembly <small>see note 1</small>	A	B	C	D <small>see note 2</small>	E <small>(see note 3)</small>			F	G	H	I	J
							Min	Min LB	Min CS					
SS MS 12	12	SS S/U 13	40	-	36	22.2	14	32	-	34.9	-	12	23	7.4
SS NMS 12	12	SS S/U 13	40	-	36	22	14	32	-	34.7	-	12	23	7.4
SS S 25	25	SS S/U 25	80	76.4	73	46.3	26	52	56	71.3	45	18	45	11.5
SS NS 25	25	SS S/U 25	80	76.8	73	46.1	26	52	56	71.1	45	18	45	11.5
SS S 35	35	SS S/U 25	95	86.8	83	56.2	26	52	56	81.2	45	18	55	12.5
SS S 50	50	SS S/U 25	112	101.8	98	71.3	26	52	56	96.3	45	18	70	14.0
SS M 44	44	SS S/U 34	116	113.1	107	72.1	35	70	71	106.1	56	25	69	14.5
SS NM 44	44	SS S/U 34	116	113.1	107	71.9	35	70	71	105.9	56	25	69	14.5
SS M 60	60	SS S/U 34	135	129.1	123	88	35	70	71	122	56	25	85	17.0
SS M 76	76	SS S/U 34	150	145.1	139	104	35	70	71	138	56	25	101	18.0
SS L 76	76	SS S/U 54	185	179.7	171	118.8	55	106	99	172.8	80	38	114	20.0
SS NL 76	76	SS S/U 54	185	179.7	171	118.6	55	106	99	172.6	80	38	114	20.0

Notes:

- Bearing Assemblies stated above are the standard size for use with each Slide profile. Bearing Assemblies and Slides can, however be 'mixed and matched' according to practicality of design. In these cases the following should be noted:
 - Cap Seals may only be used with Slides which are of the same thickness or thicker than the standard Slides quoted in the table
 - Lubricators may only be used with Slides of the same thickness or thinner than the standard Slides in the table above.
 - Non-standard combinations will have different assembled dimensions - these can be calculated by referring to the individual components dimension tables, taking care to use 'theoretical apex' 'V' dimensions to calculate Bearing Assembly drilling centres.

Assembled Systems

The dimensions shown in the tables relate to the standard combination of Bearing Assembly and Slide. However, since a common 70° angle is maintained, Hepco components may be 'mixed and matched' in most circumstances (see note 1).

Assembled Systems Incorporating Carriage Plates, Through Hole Fixing Bearing Assemblies and Lubricators

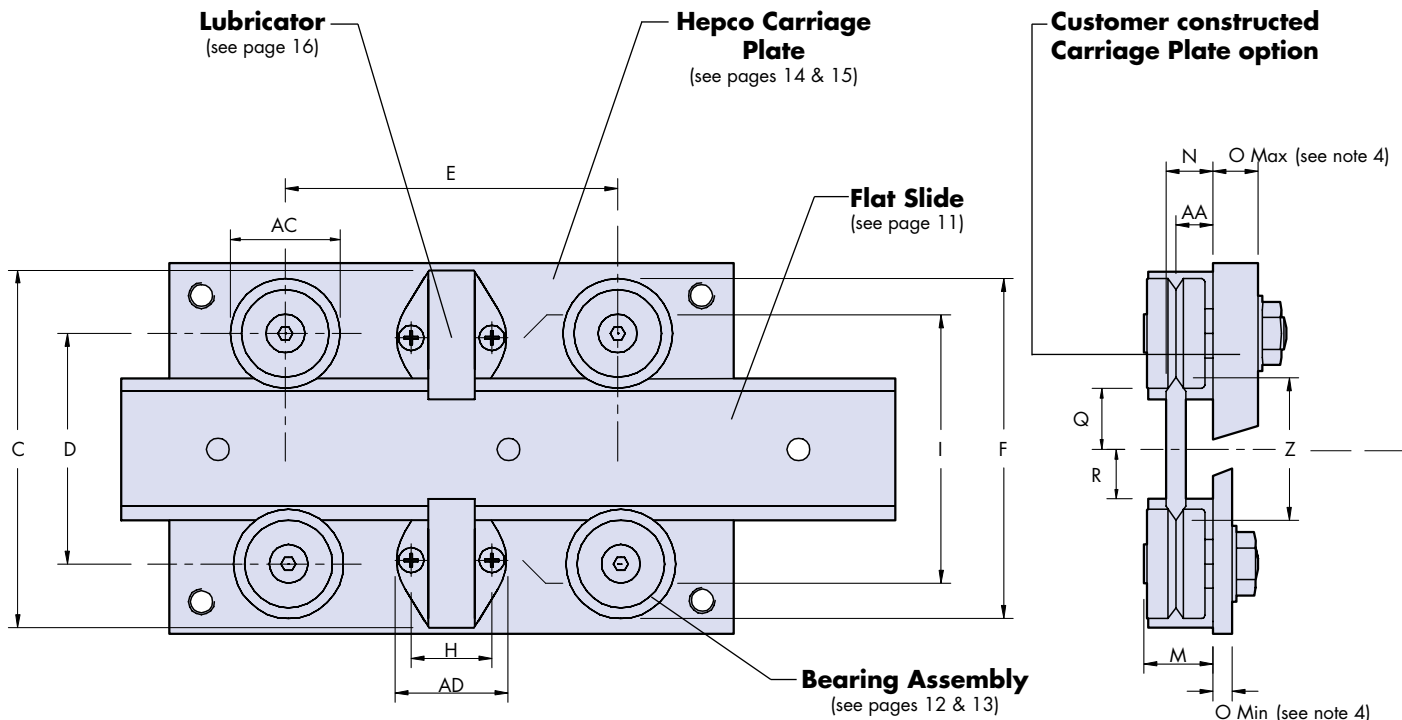

	K	L	M	N	O min see note 4	O max see note 4	P	Q	R	S	T	AA	AB	AC	AD	Z Size ~	Slide Section see note 1
	-	-	10.1	6.95	2.5	6	-	4.8	5	-	-	5.46	-	12.7	17	12	SS MS 12
	11.67	19.06	10.1	-	2.5	6	8.5	4.7	5	-	-	5.46	-	12.7	17	12	SS NMS 12
	-	-	16.6	11.35	2.5	13	-	10.7	8.5	8.4	-	9	55	25	25	25	SS S 25
	19	30.5	16.6	-	2.5	13	15	10.6	8.5	8.4	1	9	55	25	25	25	SS NS 25
	-	-	16.6	11.35	2.5	13	-	15.6	13.5	13.4	-	9	55	25	25	35	SS S 35
	-	-	16.6	11.35	5.5	13	-	23.2	21	20.9	-	9	55	25	25	50	SS S 50
	-	-	21.3	14.57	5.5	14	-	19	15.5	16.5	-	11.5	70	34	34	44	SS M 44
	24	38.5	21.3	-	5.5	14	26	19	15.5	16.5	1.5	11.5	70	34	34	44	SS NM 44
	-	-	21.3	14.57	5.5	14	-	27	23.5	24.5	-	11.5	70	34	34	60	SS M 60
	-	-	21.3	14.57	5.5	14	-	35	31.5	32.5	-	11.5	70	34	34	76	SS M 76
	-	-	34.7	23.56	6	20	-	32.4	28.5	29.8	-	19	98	54	50	76	SS L 76
	38.5	58.5	34.7	-	6	20	50	32.3	28.5	29.8	2	19	98	54	50	76	SS NL 76

Notes (continued):

- Customers constructing their own Carriage Plate should drill the Bearing Assembly hole centres according to 'D' dimension, to a recommended tolerance of $\pm 0.2\text{mm}$. Holes should be drilled and reamed to size and tolerance per 'R' dimension, page 15.
- Although Dimension 'E' is expressed as minimum values, it is recommended wherever possible to have $E > D$ for rigidity purposes. Dimension 'E', Min CS and Min LB refer to the minimum Bearing Assembly spacing when Customers are using Hepco Cap Seals (CS) or Lubricators (LB) with their own Carriage Plates. The equivalent dimension for Hepco Carriages can be obtained from Carriage Plate pages 14 & 15.
- Two lengths of stud are available for each size of Bearing Assembly - choose according to your Carriage Plate thickness requirement.
- Controlled height (CHK) bearings are selected $\pm 0.010\text{mm}$ bands in respect of the B1 dimension on pages 12-13. They are supplied in sets of up to 50 parts as standard, with larger sets on request. Customers requiring CHK bearings within the same tolerance band in respect of a number of carriages should state this on their order.

Notes are continued on page 8

Assembled Systems

Blind Hole Fixing Bearing Assemblies are for use where access to the back of the mounting plate is not possible or where the thickness of the mounting plate prevents use of the Through Hole Fixing Bearing Assemblies. These circumstances are not relevant to the use of Hepco Carriage Plates, therefore systems using Blind Hole Fixing Bearing Assemblies are not available factory assembled.

Assembled Systems Incorporating Blind Hole Fixing Bearing Assemblies and Lubricators

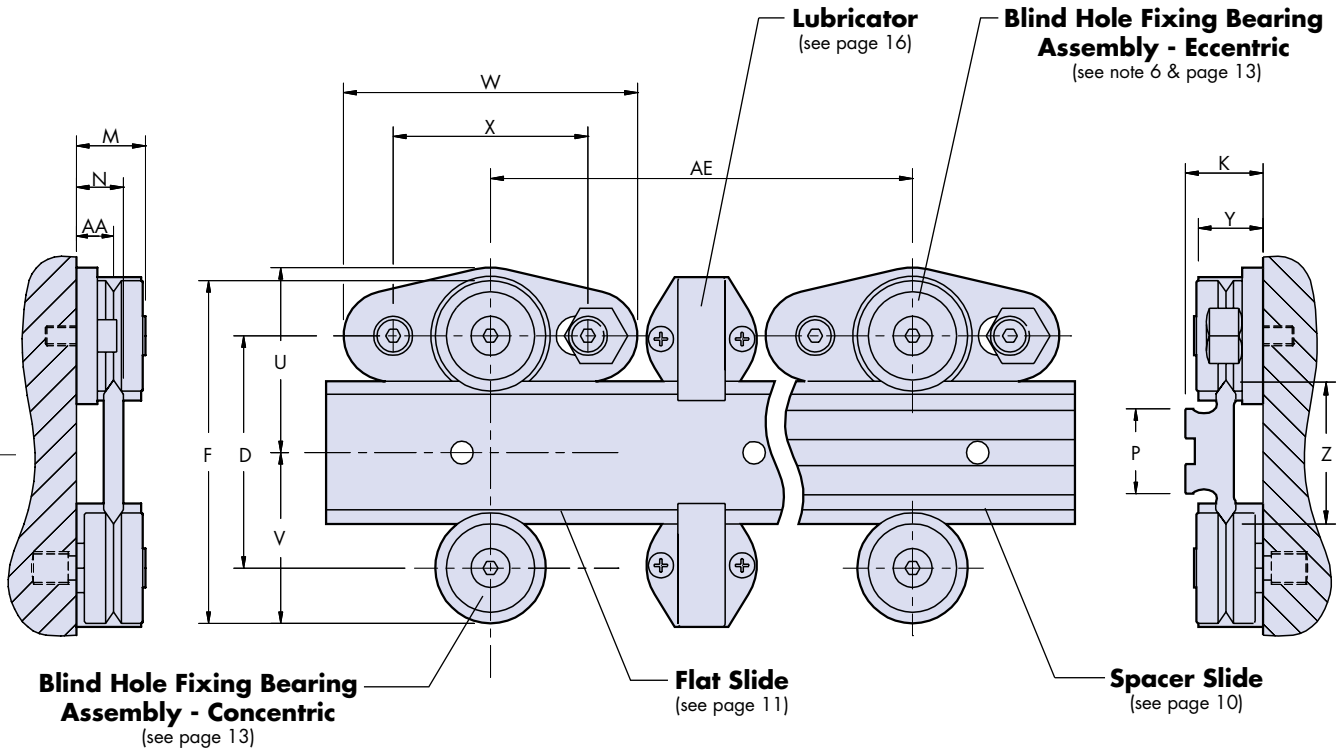

Slide Section <small>see note 1</small>	Z Size ~	Bearing Assembly <small>see note 1</small>	AA	D <small>see note 2</small>	AE <small>see note 7</small>		F	K	M	N	P	U	V	W	X	Y
					Min	Min										
SS MS 12	12	SS BHJ 13	5.46	22.2	48.5	66.5	34.9	-	10.1	6.95	-	21.1	17.5	47.5	30.0	10.0
SS NMS 12	12	SS BHJ 13	5.46	22	48.5	66.5	34.7	11.67	10.1	-	8.5	21.0	17.4	47.5	30.0	10.0
SS S 25	25	SS BHJ 25	9	46.3	73.0	99.0	71.3	-	16.6	11.35	-	39.2	35.7	72.0	50.0	16.5
SS NS 25	25	SS BHJ 25	9	46.1	73.0	99.0	71.1	19.0	16.6	-	15	39.1	35.6	72.0	50.0	16.5
SS S 35	35	SS BHJ 25	9	56.2	73.0	99.0	81.2	-	16.6	11.35	-	44.1	40.6	72.0	50.0	16.5
SS S 50	50	SS BHJ 25	9	71.3	73.0	99.0	96.3	-	16.6	11.35	-	51.6	48.2	72.0	50.0	16.5
SS M 44	44	SS BHJ 34	11.5	72.1	92.0	128.0	106.1	-	21.3	14.57	-	57.0	53.1	90.5	60.0	20.0
SS NM 44	44	SS BHJ 34	11.5	71.9	92.0	128.0	105.9	24.0	21.3	-	26	57.0	53.0	90.5	60.0	20.0
SS M 60	60	SS BHJ 34	11.5	88	92.0	128.0	122	-	21.3	14.57	-	65.0	61.0	90.5	60.0	20.0
SS M 76	76	SS BHJ 34	11.5	104	92.0	128.0	138	-	21.3	14.57	-	73.0	69.0	90.5	60.0	20.0
SS L 76	76	SS BHJ 54	19	118.8	134.0	185.0	172.8	-	34.7	23.56	-	90.4	86.4	133.0	89.5	33.5
SS NL 76	76	SS BHJ 54	19	118.6	134.0	185.0	172.6	38.5	34.7	-	50	90.3	86.3	133.0	89.5	33.5

Notes continued:

- 6. Cap Seals cannot be used with eccentric Blind Hole fixing Bearing Assemblies, as they will not fit over the adjustment mechanism.
- 7. Dimension 'AE', Min LB is the minimum Blind Hole Fixing Bearing Assembly spacing when using Hepco Lubricators.

Assembled Systems

Ordering Assembled Systems

The table below shows the combinations of components available to make up a Factory Assembled Carriage. Pages 10 to 17 detailing individual components will aid the selection of assembled systems, and will explain the relative merits of various component choices e.g. Cap Seals versus Lubricators, Twin versus Double Row Bearing Assemblies.

Once the component combination for an assembled system has been decided upon, the table below can be consulted for availability and a part number specified according to the table and the ordering details shown.

Stock SL2 Carriages In Assembled and Adjusted Condition

Part Number	Carriage Length	Available With Cap Seals	Available With Lubricators	Twin Bearing (Standard)	DR Double Row Bearing Option	CHK Controlled Height Bearing Option
AU SS MS 12	50	x	✓	✓	x	✓
	75	x	✓	✓	x	✓
	100	x	✓	✓	x	✓
AU SS S 25	80	x	✓	✓	✓	✓
	130	✓	✓	✓	✓	✓
	180	✓	✓	✓	✓	✓
AU SS S 35	100	x	✓	✓	✓	✓
	150	✓	✓	✓	✓	✓
	200	✓	✓	✓	✓	✓
AU SS S 50	110	x	✓	✓	✓	✓
	160	✓	✓	✓	✓	✓
	220	✓	✓	✓	✓	✓
AU SS M 44	125	x	✓	✓	✓	✓
	175	✓	✓	✓	✓	✓
	225	✓	✓	✓	✓	✓
AU SS M 60	150	x	✓	✓	✓	✓
	200	✓	✓	✓	✓	✓
	280	✓	✓	✓	✓	✓
AU SS M 76	170	x	✓	✓	✓	✓
	240	✓	✓	✓	✓	✓
	340	✓	✓	✓	✓	✓
AU SS L 76	200	x	✓	✓	✓	✓
	300	✓	✓	✓	✓	✓
	400	✓	✓	✓	✓	✓

Ordering Details

AUSSM44 225 (CS) (LB) (DR) (CHK) + SSNM44 626

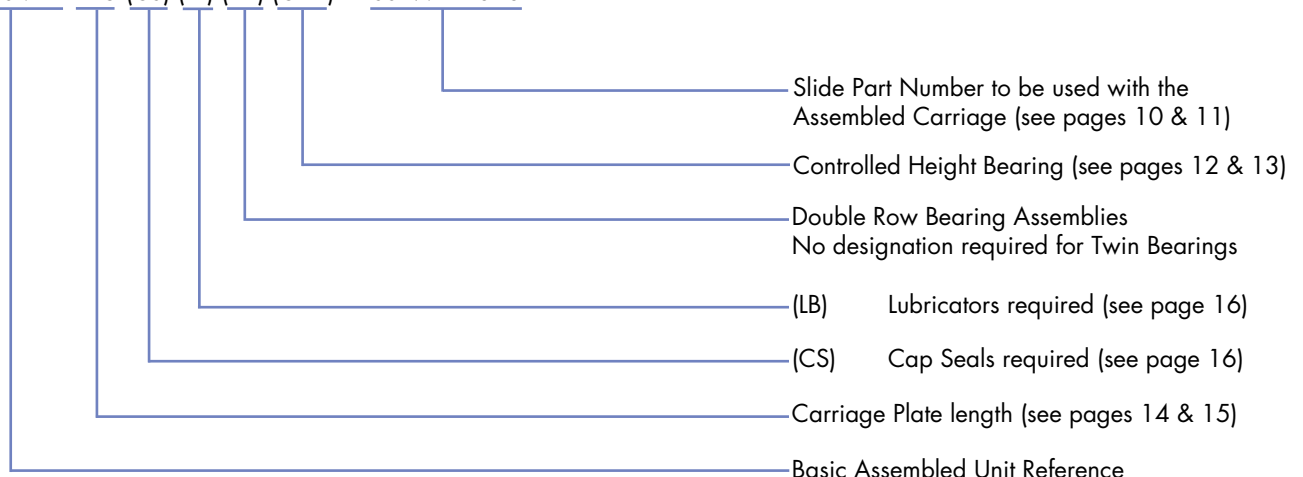

Stainless Steel Spacer and Flat Slides

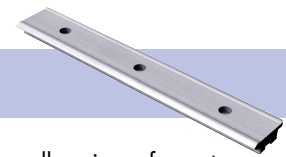

Hepco SL2 stainless steel Slides are zone hardened on the 'V' edges and precision ground on all main surfaces to a high degree of parallelism. Slide fixing holes are accurately positioned, allowing Customers to pre-drill their mounting holes. All Hepco Slides are left 'soft' in the centre portion for subsequent machining if required. However, since SL2 Slides are specially finished to promote resistance to corrosion, Customers should be aware that machining may reduce localised corrosion resistance. To maximise corrosion resistance following machining, polishing is recommended. Two varieties of Slide are available, **Spacer type** and **Flat type**.

Spacer Slide

A one piece construction that bolts directly to the mounting surface of the machine, providing adequate running clearance for Bearing Assemblies, Cap Seals and Lubricators. A central keyway is provided for simple location by means of Hepco -

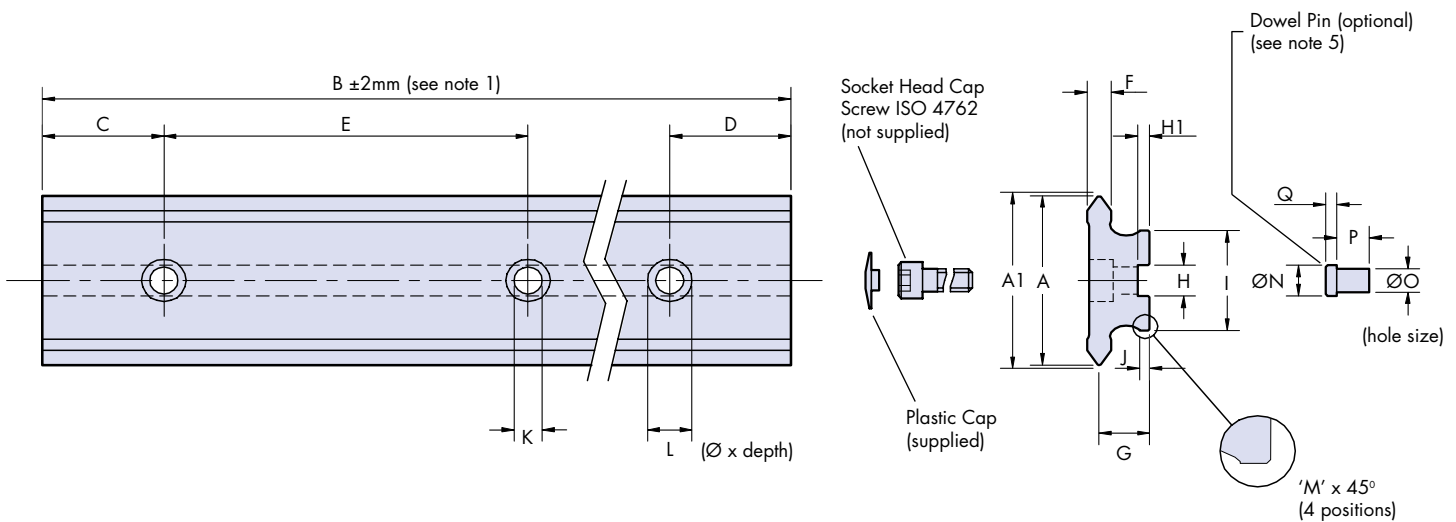

Part Number		Use With Bearing Ø see note 3	A ~	A1 Theoretical Apex	B Max see note 1	C	D	E ±0.1 Non Acc.	F	G	H +0.05 - 0.00	H1	I ±0.025	J	
Spacer Slide	Flat Slide														
SS NMS 12		13	12	12.37	1976	20.5	20.5	45	3	6.2	4	1.8	8.5	1.7	
	SS MS 12	13	12	12.55	1016	13	13	30	3	-	-	-	-	-	
SS NS 25		25	25	25.74	4020	43	43	90	4.5	10	6	2.5	15	2.5	
	SS S 25	25	25	25.81	4020	43	43	90	4.7	-	-	-	-	-	
	SS S 35	25	35	35.81	4020	43	43	90	4.7	-	-	-	-	-	
	SS S 50	25	50	50.83	4020	43	43	90	4.7	-	-	-	-	-	
SS NM 44		34	44	44.74	4020	43	43	90	6	12.5	8	3	26	2.5	
	SS M 44	34	44	44.81	4020	43	43	90	6.1	-	-	-	-	-	
	SS M 60	34	60	60.81	4020	43	43	90	6.1	-	-	-	-	-	
	SS M 76	34	76	76.81	4020	43	43	90	6.1	-	-	-	-	-	
SS NL 76		54	76	76.74	4020	88	88	180	9	19.5	15	5	50	5	
	SS L 76	54	76	76.81	4020	43	43	90	9.1	-	-	-	-	-	

Notes:

- Any length of Slide within B Max dimension can be supplied, but for optimum price and delivery time, Slide lengths should be specified which maintain the C and D dimensions in the table above. In all cases unless otherwise specified by the Customer, C and D dimensions will be supplied equal. Customers are requested to ensure that the proximity of the fixing holes to the ends of the Slide will accommodate the Fixing Screws and to note that Slide lengths which bisect the fixing holes will require dimensions C and D to be specified unequal.
- Where longer Slides are required, standard lengths can be matched suitable for butting, on request. In these cases the mating ends will be ground square and additional holes may be inserted to give support near the joins. A light stoning of the 'V's will be necessary after installation to ensure smooth travel across the joins.
- In the table, the standard size of Bearing diameter to use with each Slide is quoted. However, other combinations are possible - please see page 6 note 1 for further details.
- Fixing screws for Flat Slides must have head length sufficient to clear the Carriage. Low head socket cap screws DIN 7984 provide sufficient clearance and are available from Hepco (see table).
- Slides in their free unmounted state are not necessarily straight. If straightness is important, the Slide may be set straight by bolting down against a register or by utilising the central keyway. If Hepco Dowel Pins are used, these should be positioned one each end midway between the Slide end and first hole. Also, midway between all fixing hole centres, or as deemed necessary for the application.

Stainless Steel Spacer and Flat Slides

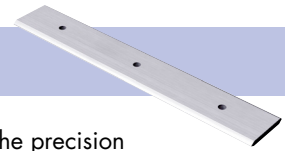

- Dowel Pins or Customer's own key. In cases where Cap Seals or Lubricators are not being used, the precision datum edges on the spacer portion of the Slide may be utilised for location against a machined register. The rigidity of the Spacer Slide enables it to be used as a self-supporting element or construction member of the machine, when used in conjunction with Hepco Flange Clamps (see pages 17 and 22). Plastic caps are provided with all Spacer Slides to close off debris traps at the hole positions. These caps engage in the sockets of the fixing screws.

Flat Slide

Designed for Customers who prefer to bolt the Slide to a spacer which is part of their own machine construction. Where the Slide is required to be the moving component an aluminium spacer plate can be constructed in order to reduce inertia.

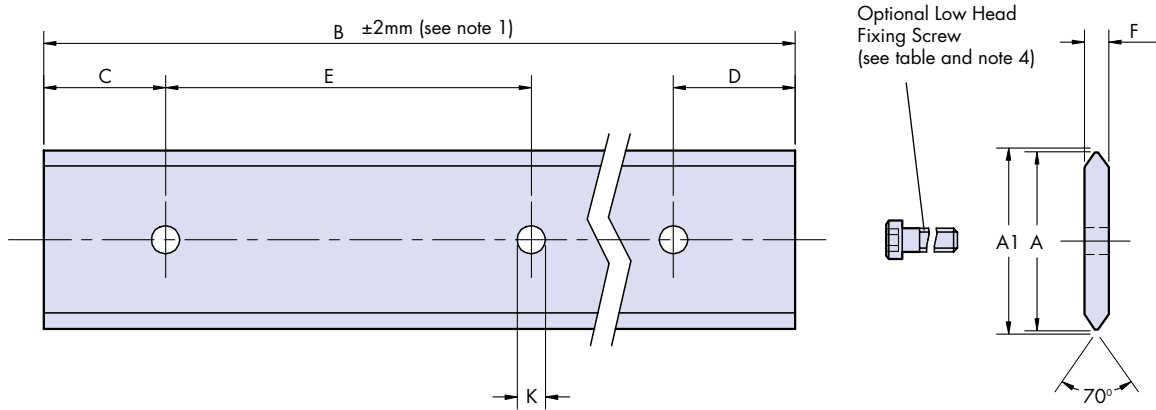

	K	L	M	Dowel Pin Option (see note 5)					Flat Slide Fixing Screw (see note 4)			Mass~g /100mm	Part Number	
				Part No.	N m6	O K6	P	Q	Part No.	Thread	Length		Spacer Slide	Flat Slide
	3.5	6 x 3	-	SS SDP 4	4 $\begin{smallmatrix} +0.012 \\ +0.004 \end{smallmatrix}$	4 $\begin{smallmatrix} +0.002 \\ -0.006 \end{smallmatrix}$	6.75	-	-	-	-	44	SS NMS 12	
	3.5	-	-	-	-	-	-	-	SS FS 3-8	M3	8	23		SS MS 12
	5.5	10 x 5	1.0	SS SDP 6	6 $\begin{smallmatrix} +0.012 \\ +0.004 \end{smallmatrix}$	4 $\begin{smallmatrix} +0.002 \\ -0.006 \end{smallmatrix}$	6	2.25	-	-	-	140	SS NS 25	
	7	-	-	-	-	-	-	-	SS FS 6-16	M6	16	82		SS S 25
	7	-	-	-	-	-	-	-	SS FS 6-16	M6	16	130		SS S 35
	7	-	-	-	-	-	-	-	SS FS 6-16	M6	16	170		SS S 50
	7	11 x 6	1.0	SS SDP 8	8 $\begin{smallmatrix} +0.015 \\ +0.006 \end{smallmatrix}$	6 $\begin{smallmatrix} +0.002 \\ -0.006 \end{smallmatrix}$	8	2.75	-	-	-	330	SS NM 44	
	7	-	-	-	-	-	-	-	SS FS 6-20	M6	20	190		SS M 44
	9	-	-	-	-	-	-	-	SS FS 8-20	M8	20	265		SS M 60
	9	-	-	-	-	-	-	-	SS FS 8-20	M8	20	340		SS M 76
	14	20 x 12	1.0	SS SDP 15	15 $\begin{smallmatrix} +0.018 \\ +0.007 \end{smallmatrix}$	10 $\begin{smallmatrix} +0.002 \\ -0.007 \end{smallmatrix}$	15	4.75	-	-	-	1000	SS NL 76	
	11.5	-	-	-	-	-	-	-	SS FS 10-25	M10	25	500		SS L 76

Ordering Details

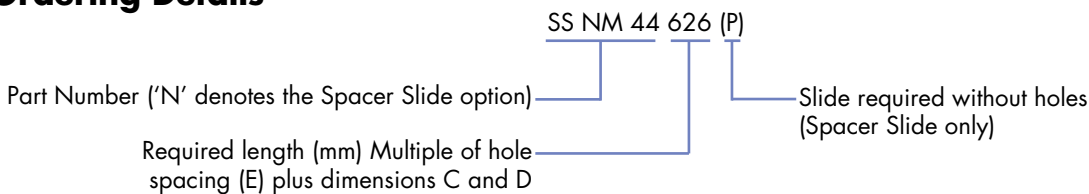

Example:

1 x SS NS 25 536
6 x SS SDP6

Stainless steel Spacer Slide x 536mm long
6mm Ø head, stainless steel Dowel Pins

Stainless Steel Bearing Assemblies



A number of Bearing Assembly options are available from Hepco in order to cater for most design requirements. The **Through Hole Fixing type** is available in two stud lengths covering most thicknesses of carriage or mounting plate, the short stud version being compatible with the Hepco Carriage Plates.

The **Blind Hole Fixing type** allows mounting into a solid machine base where through mounting holes are not possible, or where the thickness of the mounting plate is too great. The Blind Hole Fixing type is also useful where adjustment from the front is preferred, or where access to the opposite side of the mounting hole is restricted.

The Blind Hole Fixing eccentric type Bearing Assemblies will not accommodate Cap Seals, however Hepco Lubricators may be specified, as a means of applying lubrication to the system. Both varieties of Bearing Assembly are available with two types of bearing configuration.

Through Fixing Type (SS SJ/SS LJ)

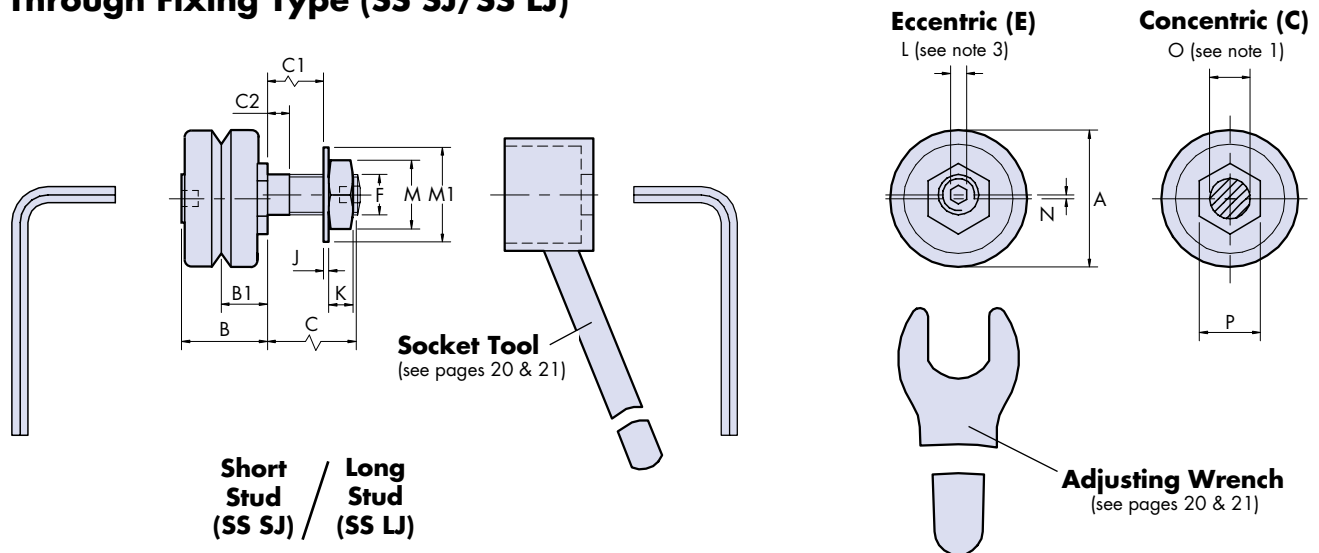

Extended range of journals available – Contact our technical department for details

Part Number	For use with Slide Reference (see note 6)	A	B	B1	SS SJ	SS LJ	SS SJ	SS LJ
					C	C	C1	C1
SS SJ/SS LJ 13 C/E / SS BHJ 13 C/E	MS/NMS	12.7	10.1	5.46	5.8	9.5	3	6
SS SJ/SS LJ 25 C/E / SS BHJ 25 C/E	S/NS	25	16.6	9	9.8	19	4	13
SS SJ/SS LJ 34 C/E / SS BHJ 34 C/E	M/NM	34	21.3	11.5	13.8	22	6	14
SS SJ/SS LJ 54 C/E / SS BHJ 54 C/E	L/NL	54	34.7	19	17.8	30	8	20

Q	R	S	S1	T	T1	T2	±0.2 U	U1	V	W	X	Y
1.5	1.0	6.25	8	8	3.75	6.75	30	47.5	8	20	M3 x 0.5	5.5
3	1.5	7	8.5	12	5	10	50	72	14	32	M5 x 0.8	8.5
4	2.0	9.5	8.5	17.5	6.5	12.5	60	90.5	17	42	M6 x 1	10
8	3.0	14.5	14	23.5	10.5	18.5	89.5	133	25	62	M8 x 1.25	13

Notes:

1. It is recommended that holes to suit Bearing Assembly mounting studs should be reamed to tolerance as per dimension R on page 15.
2. Thread form is metric fine. See dimension 'F' in table above.
3. All Through Fixing type eccentric Bearing Assembly studs are supplied with sockets for adjustment as shown, with the exception of size 13.
4. Nuts and washers are supplied with all Through Fixing type Bearing Assemblies.
5. 'R' dimension is both the eccentric offset of the adjusting nut and the total adjustment available at the bearing centre line for 360° rotation of the adjusting nut.
6. Each size of Bearing Assembly has been designed for use with a specific thickness of Slide. This is designated within the Slide part number by references as shown in the table above. However, any Bearing Assembly may be used in conjunction with any Slide according to practicality of design (see note 1 page 6).
7. Double Row Bearing Assemblies are not available for size 13 Bearing Assemblies.
8. Controlled height (CHK) bearings are selected ± 0.010mm bands in respect of the B1 dimension. They are supplied in sets of up to 50 parts as standard, with larger sets on request.

Stainless Steel Bearing Assemblies



The **Twin Bearing type** comprises two individual deep groove ball bearings on a single stud. This construction offers some compliance, which allows smoother running and is more tolerant of misalignment or uneven mounting surface. The **Double Row type** (see note 7) is a one piece construction bearing with two ball tracks. This removes potential dirt traps and offers higher load capacity (particularly radially), plus longer life.

Both types of bearing have been designed specially for slide system applications and the performance confirmed by rigorous testing. Their external dimensions are identical.

The **Controlled Height Bearing** option (CHK) minimises variation between bearings in respect of the important 'B1' dimension. This is desirable in high precision applications*8.

Blind Hole Fixing type (SS BHJ)

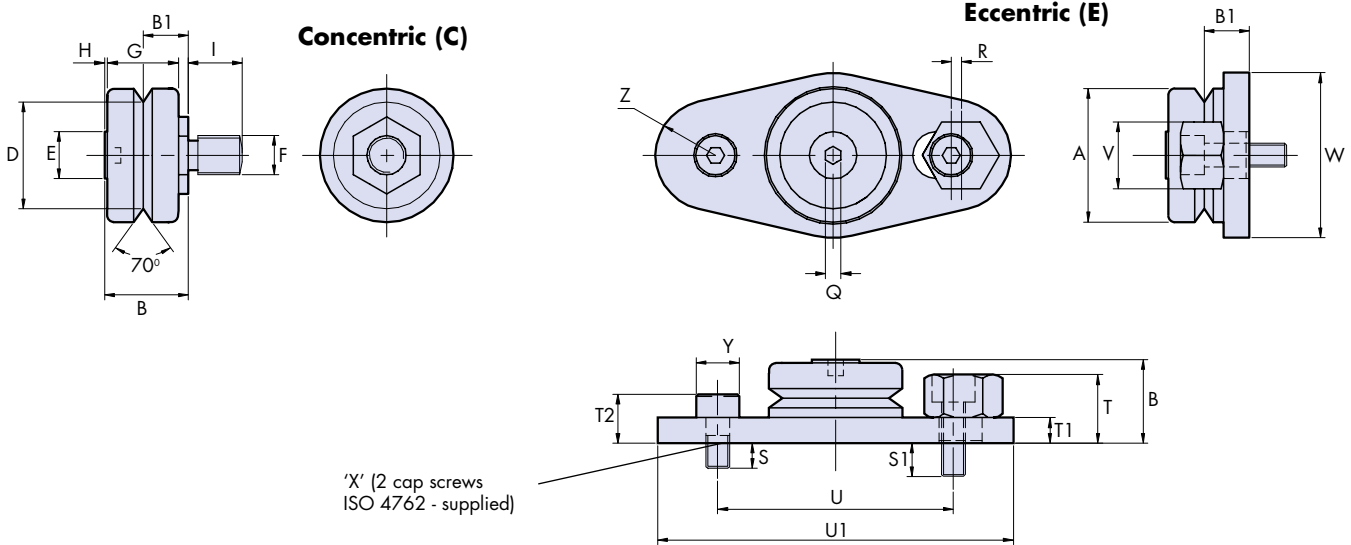

Extended range of journals available – Contact our technical department for details

		± 0.025												$+0.00$ -0.03	
	C2	D	E	F	G	H	I	J	K	L	M	M1	N	O	P
	2.5	9.51	5	M4 x 0.5	8	0.5	6	0.8	2	-	7	9	0.5	4	7
	2.5	20.27	10	M8 x 1	14	0.5	10	1	5	3	13	17	0.75	8	13
	5.5	27.13	12	M10 x 1.25	18	0.7	14	1.25	6	4	17	21	1.0	10	15.2
	6	41.76	25	M14 x 1.5	28	1.6	18	1.6	8	6	22	28	1.5	14	27

	Mass ~g				Part Number
	SS SJ C/E	SS LJ C/E	SS BHJ C	SS BHJ E	
Z					
8	8	8	7	27	SS SJ/LJ 13 C/E / SS BHJ 13 C/E
10	48	51	43	105	SS SJ/LJ 25 C/E / SS BHJ 25 C/E
14	115	120	105	235	SS SJ/LJ 34 C/E / SS BHJ 34 C/E
20	415	425	390	800	SS SJ/LJ 54 C/E / SS BHJ 54 C/E

Ordering Details:

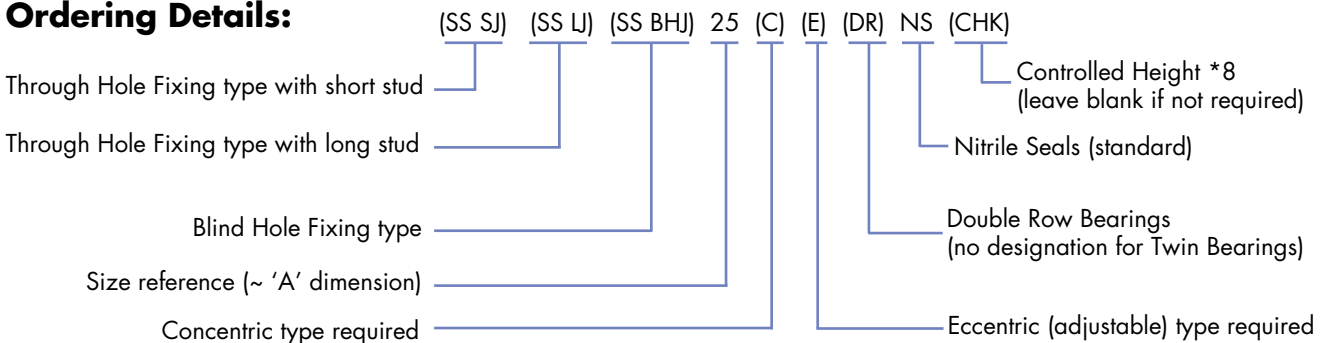

Example:

2 x SS SJ 34 C NS Stainless steel short stud size 34 concentric Bearing Assemblies with Twin bearings and standard Nitrile Seals
 2 x SS SJ 34 E NS Stainless steel short stud size 34 eccentric Bearing Assemblies with Twin Bearings and standard Nitrile Seals

Aluminium Carriage Plates



Hepco lightweight aluminium Carriage Plates are finished with a proprietary U.S. Dept. of Agriculture approved corrosion resistant coating. For convenience and reliability it is recommended that customers specify complete factory assembled systems (see page 9). Individual Carriage Plates are available for customers who prefer to carry out their own assembly.

Carriage Plates Type 'A' (will accommodate Hepco Cap Seals or Lubricators)

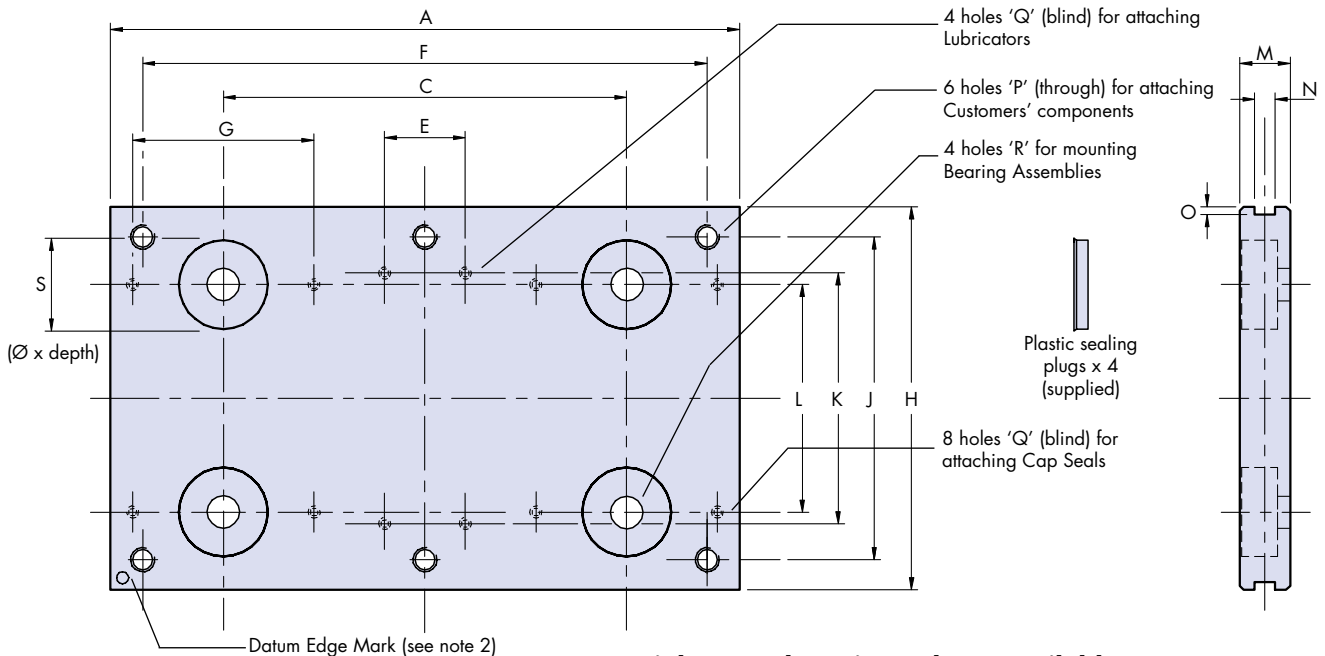

Stainless Steel Carriage Plates available on request

Part Number	For Use With		Type 'A'	Type 'B'	C	D	E	F	G	H
	Slide	Bearing								
SS CP MS12	MS/NMS 12	13		50	35	18	12	-	-	40
				75	60	25		-	-	
				100	85	50		-	-	
SS CP S25	S/NS 25	25		80	51	25	18	-	-	80
				130	72	-		110	45	
				180	120	-		160	45	
SS CP S35	S 35	25		100	70	40	18	-	-	95
				150	90	-		130	45	
				200	140	-		180	45	
SS CP S50	S 50	25		110	80	50	18	-	-	112
				160	100	-		140	45	
				220	160	-		200	45	
SS CP M44	M/NM 44	34		125	88	50	25	-	-	116
				175	103	-		155	56	
				225	153	-		205	56	
SS CP M60	M 60	34		150	110	60	25	-	-	135
				200	125	-		180	56	
				280	205	-		260	56	
SS CP M76	M 76	34		170	130	80	25	-	-	150
				240	165	-		220	56	
				340	265	-		320	56	
SS CP L76	L/NL 76	54		200	140	90	38	-	-	185
				300	198	-		270	80	
				400	298	-		370	80	

Notes:

- The recesses along the edges of the Carriage Plate provide a means to locate switch cams or other components.
- The Datum Edge Mark identifies the reference edge used in manufacture. Customers may therefore use this edge as a location to achieve best accuracy in relation to hole positions. It is normal to mount the Concentric Bearing Assemblies on this side.
- Customers constructing their own Carriage Plate should refer to pages 6 & 7 (Assembled Systems), and drill Bearing Assembly hole centres according to 'D' dimension and note 2 (Bearing Assembly centres as per 'L' dimension above are slightly different for reasons of interchangeability with other Hepco products).

Aluminium Carriage Plates

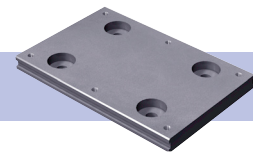

There is a range of three useful lengths in each size, available in two different types according to whether or not the Carriage Plate length will accommodate Cap Seals and Lubricators (Type 'A') or Lubricators only (Type 'B'). Special Carriage Plates can be manufactured to customers' drawings, in various materials including most grades of stainless steel.

Carriage Plates Type 'B' (will accommodate Lubricators only)

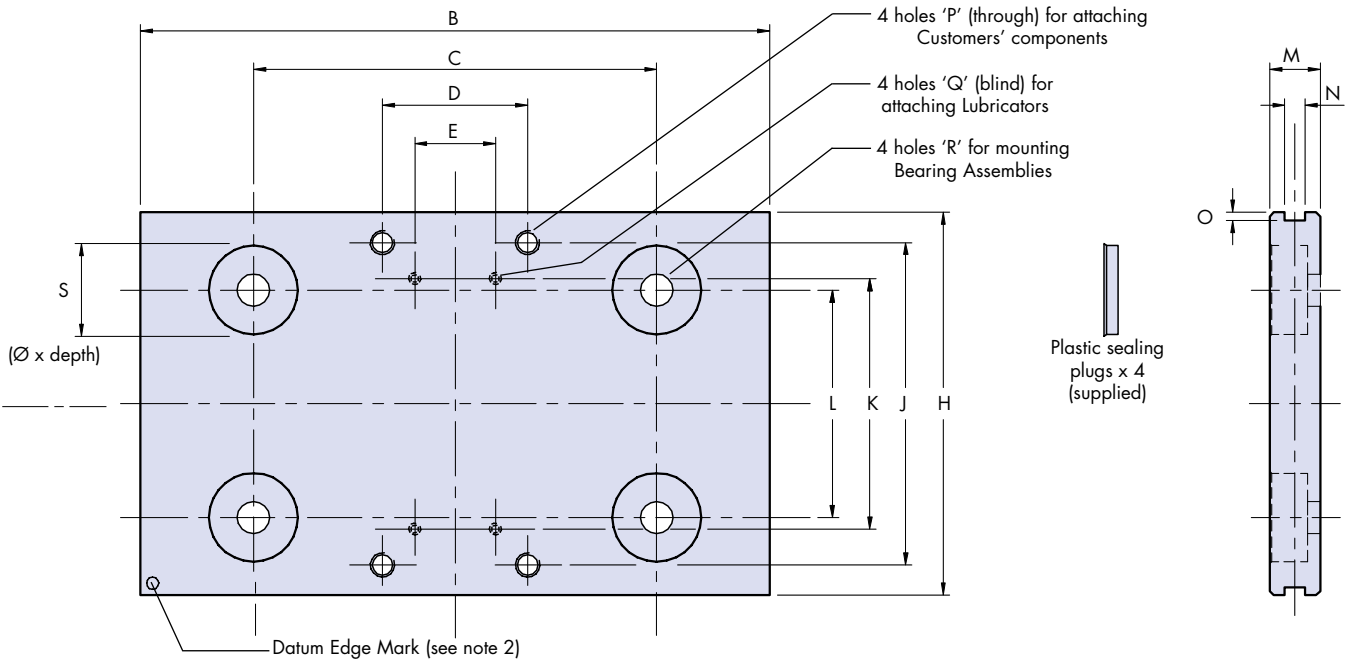

Stainless Steel Carriage Plates available on request

	J	K	L see note 3	M +0.08 -0.00	N O see note 1		P	Q	R Ø	S	Mass ~kg	Part Number
	30	23	22	7.34	3	1.5	M4 x 0.7	M2.5 x 0.45 x 4	4 $\begin{smallmatrix} +0.008 \\ +0.018 \end{smallmatrix}$	12.5 x 4.8	0.03 0.05 0.06 0.16	SS CP MS12
	64	45	46.4	11.5	5	2	M6 x 1.0	M3 x 0.5 x 5	8 $\begin{smallmatrix} +0.010 \\ +0.022 \end{smallmatrix}$	22 x 8.4	0.28 0.4	SS CP S25
	80	55	56.43	12.5	5	2	M6 x 1.0	M3 x 0.5 x 5	8 $\begin{smallmatrix} +0.010 \\ +0.022 \end{smallmatrix}$	22 x 9.4	0.28 0.44 0.59	SS CP S35
	95	70	71.43	14	5	2	M6 x 1.0	M3 x 0.5 x 5	8 $\begin{smallmatrix} +0.010 \\ +0.022 \end{smallmatrix}$	22 x 10.9	0.41 0.61 0.87	SS CP S50
	96	69	72.29	14.5	6	2	M8 x 1.25	M4 x 0.7 x 8	10 $\begin{smallmatrix} +0.010 \\ +0.022 \end{smallmatrix}$	25 x 8.7	0.5 0.71 0.93 0.85	SS CP M44
	115	85	88.29	17.0	6	2	M8 x 1.25	M4 x 0.7 x 8	10 $\begin{smallmatrix} +0.010 \\ +0.022 \end{smallmatrix}$	25 x 11	1.13 1.64	SS CP M60
	130	101	104.29	18.0	6	2	M8 x 1.25	M4 x 0.7 x 8	10 $\begin{smallmatrix} +0.010 \\ +0.022 \end{smallmatrix}$	25 x 12.5	1.15 1.64 2.37	SS CP M76
	160	114	119.06	20.0	8	4	M10 x 1.5	M5 x 0.8 x 7	14 $\begin{smallmatrix} +0.015 \\ +0.027 \end{smallmatrix}$	32 x 13.5	1.81 2.77 3.74	SS CP L76

Ordering Details:

Part Number SS CP M44 225 (A) (B)
 (M44 denotes corresponding Slide reference)
 Required length (mm) _____
 _____ Type 'B' (accommodates Lubricators)
 _____ Type 'A' (accommodates Lubricators or Cap Seals)

Example: 1 x SS CP S25 80 B Carriage Plate type B to suit an S/NS25 Slide (will accommodate Lubricators only)

Cap Seals and Lubricators

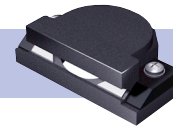

Cap Seals

Flexible plastic Cap Seals fit over the individual Bearing Assemblies, providing effective sealing and protection, plus wiping of debris from the Slide profile. Lubrication of the 'V' surface is provided by means of oil-impregnated felt wipers.

The internal cavity is filled with grease via the lubrication points, further improving lubrication and recharging the felt wipers as the grease partially liquefies under operation. Most systems require no further lubrication during the lifetime of the machine (see note 3). Fitment of these seals increases load, life and linear speed capability as well as improving operator safety.

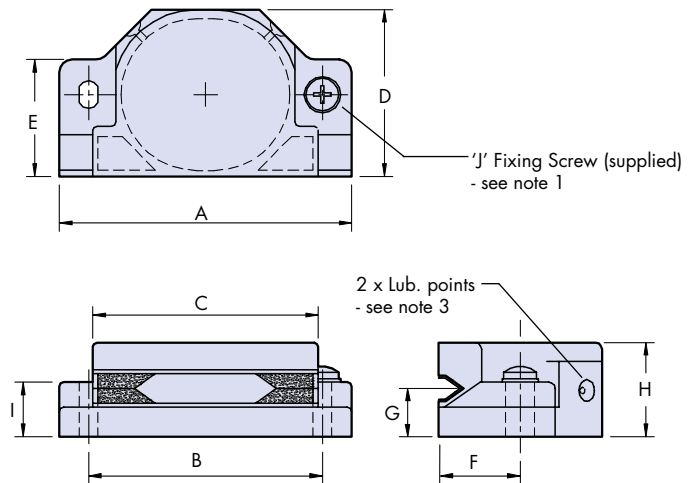

Part Number	Use With Bearing Ø/Slide Ref.	A	B	C	D	E	F	G	H	I	J	Mass ~g
SS CS 25	25 / S/NS	55	45	43	30	22	14.8	9	18	8.5	M3 x 0.5 x 12	13
SS CS 34	34 / M/NM	70	56	54	40	28	19.6	11.5	22.5	13	M4 x 0.7 x 20	28
SS CS 54	54 / L/NL	98	80	78	60	40	29.7	19	36.5	20	M5 x 0.8 x 25	78

- Notes:**
- 2 x Stainless Steel Cross Recessed Cheese Head Screws DIN84A and washers DIN125A are supplied with each Cap Seal.
 - Cap Seals are designed for use with particular Bearing Assemblies (see table). They are normally used in conjunction with the Slide section as specified in the table, however these may also be used with any Slide of greater thickness (see pages 10 & 11, dimension 'F').
 - Replenish lubricant as necessary using a No.2 consistency lithium soap based grease. Male grease connector Part No. CSHF4034 or complete gun available from Hepco if required. Lubrication interval depends on length of stroke, duty and environmental factors.

Ordering Example: State quantity and part number: 4 x SSCS34

Lubricators

Plastic Lubricators normally fit one each side of the Slide between pairs of Bearing Assemblies. However, any number may be fitted, in any position according to requirements. Lubricators provide positive lubrication to the working surface of the Slide by means of spring-loaded oil-impregnated felt wipers which act as a reservoir.

System load capacity and life expectancy are significantly increased whilst retaining the low friction characteristics of dry running. Lubricators may be used with any SL2 Carriage Plate, and are the only choice for miniature systems (SSNMS/MS12 Slides with SSSJ13 Bearing Assemblies). They are also required, for lubrication purposes, if the BHJ Blind Hole Fixing eccentric Bearing Assemblies are used.

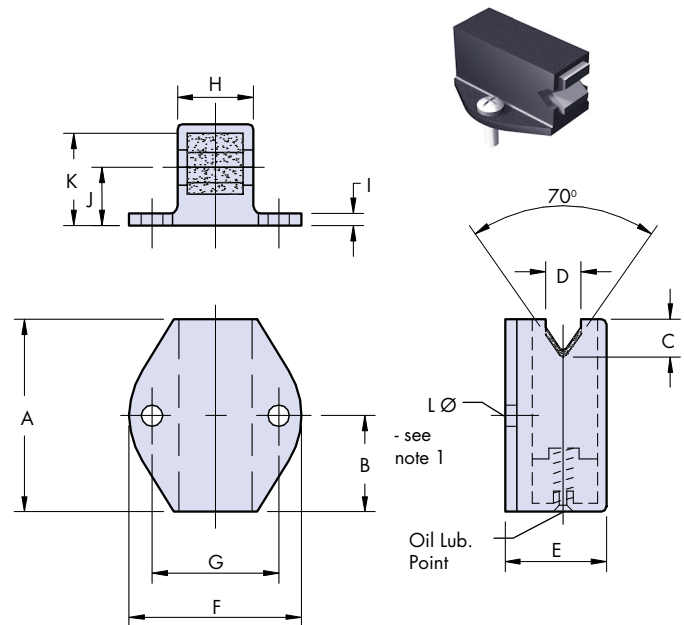

Part Number	Use With Slide (note 2)	A	B	C	D	E	F	G	H	I	J	K	L Ø	Fixing Screw	Mass ~g
SS LB 12F	SS MS/NMS	13	6.5	2.2	3.1	10	17	12	5.2	2	5.46	9	2.7	M2.5 x 0.45 x 5	2
SS LB 25F	SS S/NS	28	14	5.5	5.5	16.5	25	18	9.9	2	9	15.25	3.2	M3 x 0.5 x 6	6
SS LB 44F	SS M/NM	38	19	8	7	20	34	25	15	2.4	11.5	18.25	4.2	M4 x 0.7 x 10	16
SS LB 76F	SS L/NL	57	28.5	11.5	10	33.5	50	38	22.7	4.5	19	31.5	5.2	M5 x 0.8 x 10	44

- Notes:**
- 2 x Stainless Steel Cross Recessed Cheese Head Screws DIN84A are supplied with each Lubricator.
 - Lubricators are designed for use with particular Bearing Assemblies (see table). They are normally used in conjunction with the Slide section as specified in the table, however they may also be used with any Slide of lesser thickness (see pages 10 & 11, dimension 'F').
 - Replenishment of oil should be carried out via the lubrication point using 68 viscosity EP mineral oil. Lubrication interval depends on length of stroke, duty and environmental factors but is typically 700km of linear travel.

Ordering Example: State quantity and part number: 4 x SSLB25F

Aluminium Flange Clamps

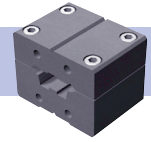

Flange Clamps enable the Slide System to act as a self-supporting constructional element of the machine. Manufactured from aluminium alloy, the clamps are then treated with a corrosion resistant coating certified by the U.S. Department of Agriculture. They are available for use with SS NS25, SS NM44, and SS NL76 section Spacer Slides only. Short Flange Clamps (type SFC) enable the Slide to be supported between two opposing faces. The Long Flange Clamp (type LFC) enables short lengths of Slide to be supported from one end only. The machined base mounting facility may be utilized by customers wishing to space the Slide System away from the mounting surface. For application illustration see page 4. For Slide deflection calculations, when used as a machine construction member, see page 22.

Assembly

During assembly, care should be taken to ensure that the Flange Clamps are positioned proud of the ends of the Slide (see note 1). Flange fixing screws should be located and slightly tightened, before clamping screws 'M' are fully tightened. Progressive tightening of each screw 'M' is recommended. Flange fixing screws may then be fully tightened.

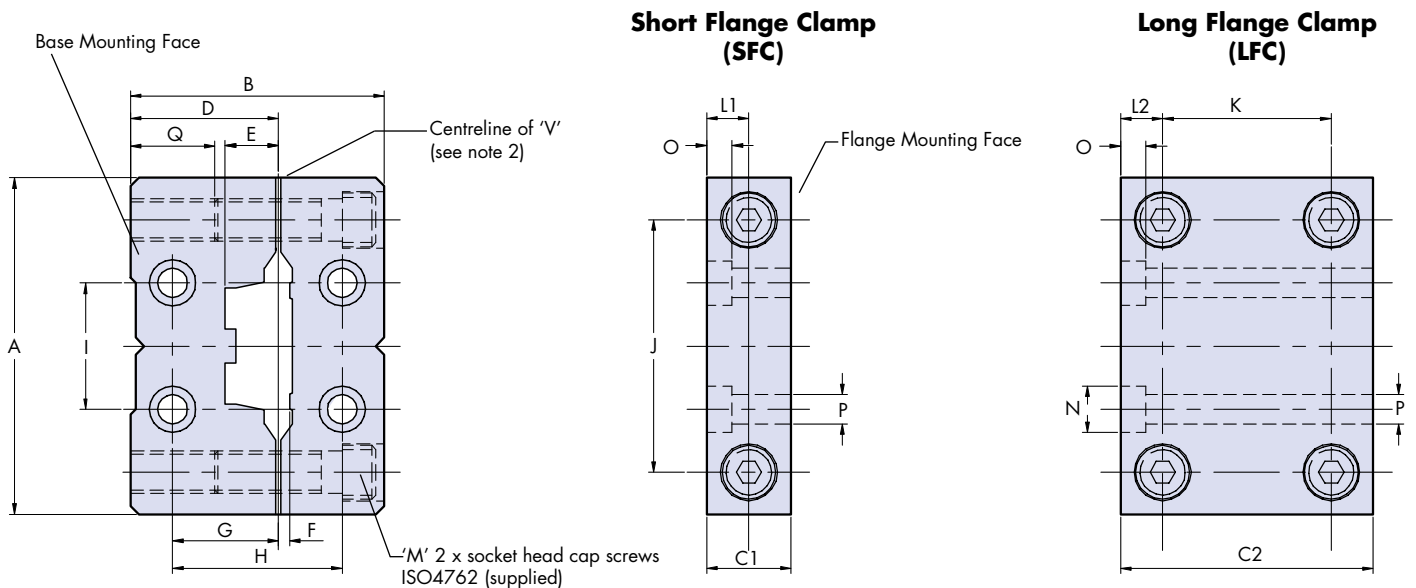

Part Number	For Use With Slide	A	B	C1	C2	D ±0.1	E	F	G	H ±0.2	I ±0.2	J	K	L1	L2	M	N	O	P	Q	Mass ~g	
																					SFC	LFC
SS SFC/LFC 25	SS NS 25	60	55	15	55	30	10	1.8	20	35	20	45	35	7.5	10	M6 x 30	9.5	5	6	17	120	405
SS SFC/LFC 44	SS NM 44	80	60	20	60	35	12.5	2.5	25	40	30	60	40	10	10	M8 x 30	11	6	7	20	220	630
SS SFC/LFC 76	SS NL 76	120	75	25	75	45	19.5	4	30	50	55	95	50	12.5	12.5	M10 x 40	14	8	9	23	495	1425

Notes:

- For mounting Slides between opposing faces, Slides should be ordered 2mm shorter than the required span.
- The drawings show dimensions from the centreline of Slide 'V' when in the clamped condition. The keyway register ensures Slide is located centrally.

Ordering Details

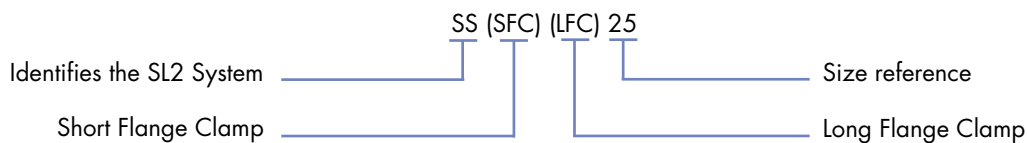

Example:

2 x SS SFC 44 Short Flange Clamps for use with Slide SSNM44
(Slide generally ordered with no holes 'P' option when using Flange Clamps - see page 10)

Technical Data

Load/Life Calculations

Maximum moment and direct load capacities for the SL2 System are given in the table below. Capacities are given for 'dry' and 'lubricated' conditions - this refers to the 'V' contact, since all Bearing Assemblies are greased for life internally. Values are based on shock-free duty.

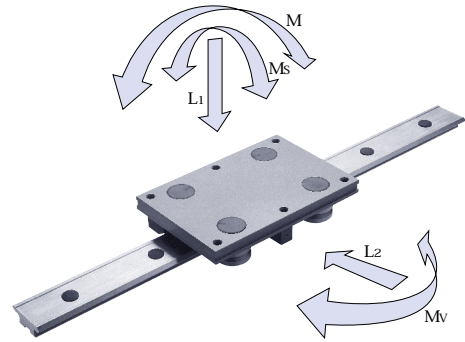

Carriage Type	Dry System, Twin & DR Type Bearing					Lubricated System, Twin Type Bearing					Lubricated System, DR Type Bearing				
	L1(max)	L2(max)	Ms(max)	Mv(max)	M(max)	L1(max)	L2(max)	Ms(max)	Mv(max)	M(max)	L1(max)	L2(max)	Ms(max)	Mv(max)	M(max)
	N	N	Nm	Nm	Nm	N	N	Nm	Nm	Nm	N	N	Nm	Nm	Nm
SSCPMS12	80	80	0.4	40 x Y	240	240	1.3	120 x Y	120 x Y		Not Applicable				
SSCPS25	320	320	3.6	160 x Y	160 x Y	960	960	11	480 x Y	480 x Y	1600	3000	17	1500 x Y	800 x Y
SSCPS35	320	320	5	160 x Y	160 x Y	960	960	15	480 x Y	480 x Y	1600	3000	25	1500 x Y	800 x Y
SSCPS50	320	320	7.3	160 x Y	160 x Y	960	960	22	480 x Y	480 x Y	1600	3000	37	1500 x Y	800 x Y
SSCPM44	640	640	13	320 x Y	320 x Y	3000	3000	60	1500 x Y	1500 x Y	3600	6000	72	3000 x Y	1800 x Y
SSCPM60	640	640	18	320 x Y	320 x Y	3000	3000	84	1500 x Y	1500 x Y	3600	6000	100	3000 x Y	1800 x Y
SSCPM76	640	640	23	320 x Y	320 x Y	3000	3000	108	1500 x Y	1500 x Y	3600	6000	129	3000 x Y	1800 x Y
SSCPL76	1440	1440	50	720 x Y	720 x Y	6000	6000	210	3000 x Y	3000 x Y	8000	10000	280	5000 x Y	4000 x Y

Calculating System Life

To calculate system life, the load factor LF should be calculated using the equation below. Where M and Mv moment loads are concerned, the M(max) and Mv(max) for the relevant Carriage Plate will need to be determined. This is established by multiplying the figure shown in the table by the spacing of the Bearing Assemblies, Y, in metres.

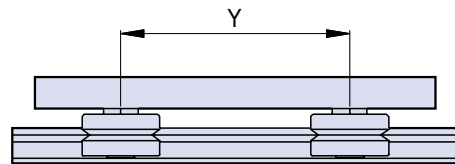

$$LF = \frac{L1}{L1(max)} + \frac{L2}{L2(max)} + \frac{Ms}{Ms(max)} + \frac{Mv}{Mv(max)} + \frac{M}{M(max)}$$

LF should not exceed 1 for any combination of loads.

Once LF is calculated, the life in km can be calculated using one of the two equations below, with Basic Life being taken from the table for the Bearing Assembly and lubrication condition applicable.

Bearing Assemblies	Basic Life Lubricated	Basic Life Dry
SS SJ/LJ/BHJ 13	40	40
SS SJ/LJ/BHJ 25	40	70
SS SJ/LJ/BHJ 25 DR	70	70
SS SJ/LJ/BHJ 34	100	100
SS SJ/LJ/BHJ 34 DR	150	100
SS SJ/LJ/BHJ 54	200	150
SS SJ/LJ/BHJ 54 DR	400	150

Dry System

$$\text{Life (km)} = \frac{\text{Basic Life}}{(LF)^2}$$

Lubricated System

$$\text{Life (km)} = \frac{\text{Basic Life}}{(LF)^3}$$

Technical Data

Load/Life Calculation Examples

Example 1

An SSCPS25 130 Carriage Plate is fitted with SSSJ25 twin type Bearing Assemblies and SSCS25 Cap Seals, mounted on an SSNS25 Spacer Slide. The Carriage carries a load of 30N offset from the centreline by 50mm as shown.

$$L_1 = 30\text{N}$$

$$M_s = L_1 \times 0.05 = 30 \times 0.05 = 1.5\text{Nm}$$

$$L_2 = M_v = M = 0$$

$$L_F = \frac{30}{960} + \frac{0}{960} + \frac{1.5}{11} + \frac{0}{(480 \times Y)} + \frac{0}{(480 \times Y)} = 0.168$$

Basic life for a lubricated system using SSSJ25 twin type Bearing Assemblies is 40km.

$$\text{Life (km)} = \frac{40}{0.168^3} = \mathbf{8436\text{km}}$$

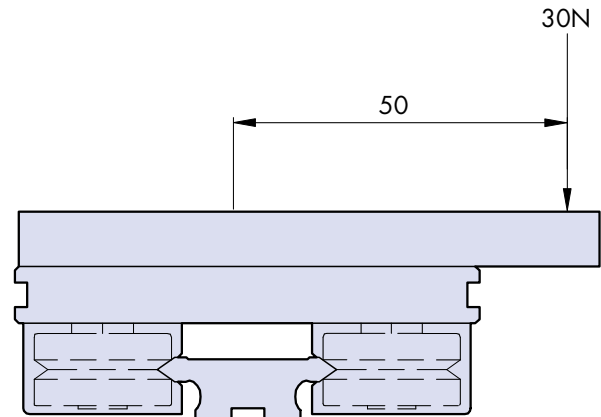

Example 2

An SSCPM44 175 Carriage Plate is fitted with SSSJ34DR Double Row Bearing Assemblies and SSCS34 Cap Seals, mounted on an SSNM44 Spacer Slide. The Carriage carries a load of 200N offset from the centreline by 150mm as shown.

$$L_1 = 200\text{N}$$

$$M = L_1 \times 0.15 = 200 \times 0.15 = 30\text{Nm}$$

$$L_2 = M_s = M_v = 0$$

Using Carriage Plate SSCPM44 175, $Y = 0.103\text{m}$

$$M_{(\text{max})} = 1800 \times 0.103 = 185.4\text{Nm}$$

$$L_F = \frac{200}{3600} + \frac{0}{6000} + \frac{0}{72} + \frac{0}{(3000 \times Y)} + \frac{30}{185.4} = 0.217$$

Basic Life for a lubricated system using SSSJ34DR Double Row Bearing Assemblies is 150km.

$$\text{Life (km)} = \frac{150}{0.217^3} = \mathbf{14680\text{km}}$$

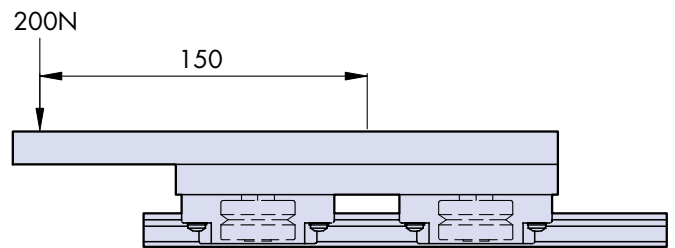

Example 3

An SSCPL76 300 Carriage Plate is fitted with SSSJ54 Twin type Bearing Assemblies mounted on an SSNL76 Spacer Slide. The 'vee' contact surface is dry. The system is raised and lowered using a ballscrew as shown. The mass being lifted is 30kg.

For system equilibrium, upward force F_1 must equal downward force F_2 ($30\text{kg} \times 9.81$) = 294.3N

F_1 gives clockwise moment, F_2 gives anti-clockwise moment.

$$M = (294.3 \times 0.12) - (294.3 \times 0.06) = 17.66\text{Nm}$$

$$L_1 = L_2 = M_s = M_v = 0$$

Using Carriage Plate SSCPL76 300, $Y = 0.198$

$$M_{(\text{max})} = 720 \times 0.198 = 142.5\text{Nm}$$

$$L_F = \frac{0}{1440} + \frac{0}{1440} + \frac{0}{50} + \frac{0}{(720 \times Y)} + \frac{17.6}{142.5} = 0.124$$

Basic life for a dry system using SSSJ54 twin type Bearing Assemblies is 150km.

$$\text{Life (km)} = \frac{150}{0.124^2} = \mathbf{9755\text{km}}$$

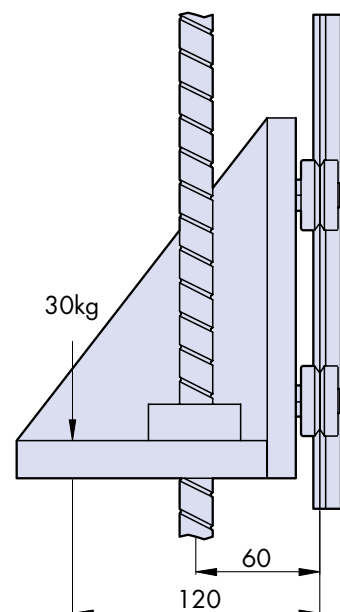

System Assembly and Adjustment

Through Fixing Type Bearing Assemblies

Having loosely assembled the components (minus load), the concentric Bearing Assemblies should be fully tightened and the eccentric Bearing Assemblies tightened just sufficiently to permit adjustment. The Hepco Adjusting Wrench should then be engaged with the hexagon flanges of the eccentric Bearing Assemblies, and gradually turned until the Slide is captivated between each pair of opposing Bearing Assemblies such that there is no apparent play, but with minimal pre-load. Each pair of Bearing Assemblies should then be checked for correct pre-load by rotating one of them between forefinger and thumb with the Slide stationary so that the bearing skids against the Slide. A degree of resistance should be felt, but the bearing should be able to be rotated without difficulty.

When all eccentric Bearing Assemblies have been adjusted and tested in this manner, the fixing nuts should be fully tightened to the recommended torque settings in the table on page 21, then checked again for correct pre-load as before.

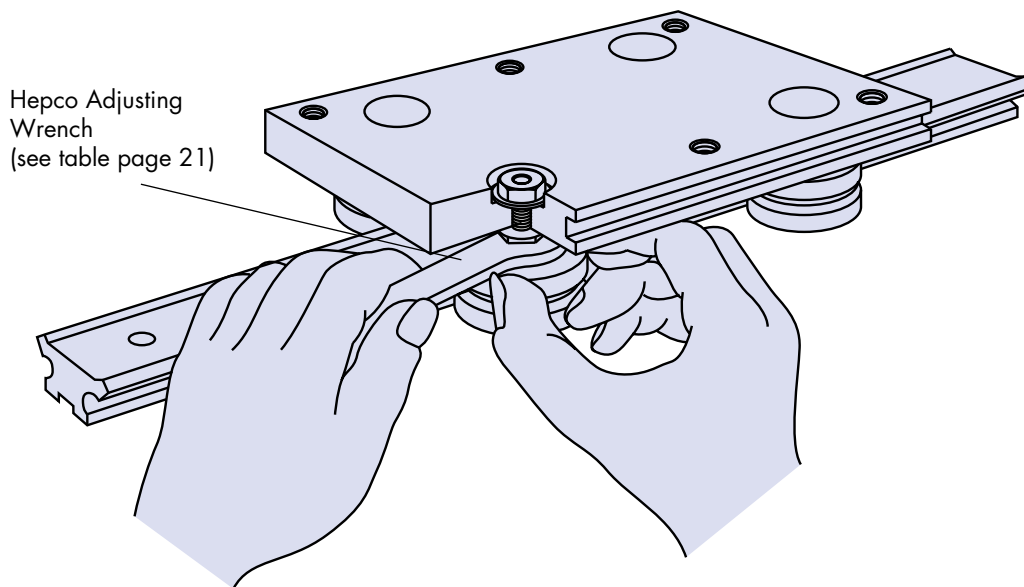

Alternative method of adjustment

The eccentric Bearing Assemblies may also be adjusted using standard Allen Key and Hepco Socket Tool. This method also permits re-adjustment without first having to remove the Cap Seals, however extreme care should be taken not to induce excessive pre-load which can only be judged in this case from the resulting friction of the system. Due to the reduced control associated with this method, it is only recommended when the Adjusting Wrench method is not possible.

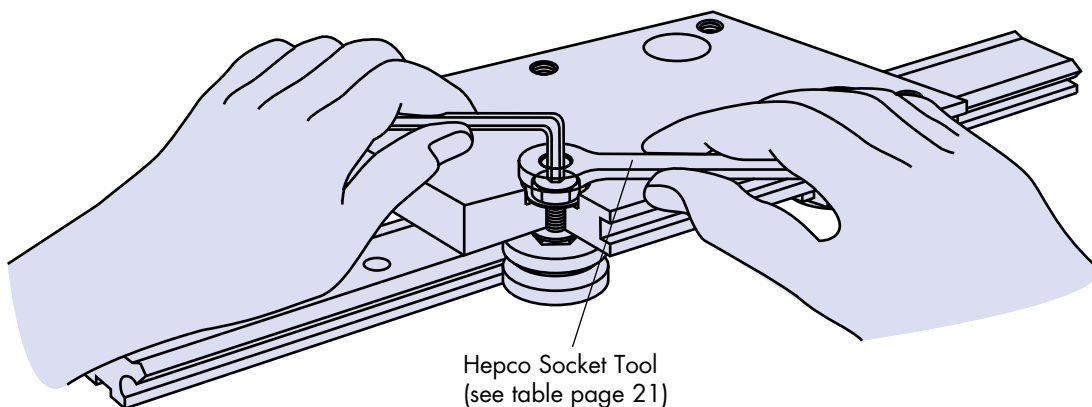

System Assembly and Adjustment

Blind Hole Fixing Type Bearing Assemblies

The Concentric Blind Hole Fixing Bearing Assemblies are simply screwed into tapped holes in the mounting surface and tightened down using the Hepco Adjusting Wrench.

Each Eccentric Bearing Assembly should be located by means of the two fixing screws provided and tightened just sufficiently to still enable adjustment via the eccentric hexagon bush. The same basic procedures as outlined for the Through Fixing type Bearing Assemblies should be used to ensure that the correct level of pre-load is applied to the bearings, before finally tightening down the fixing screws.

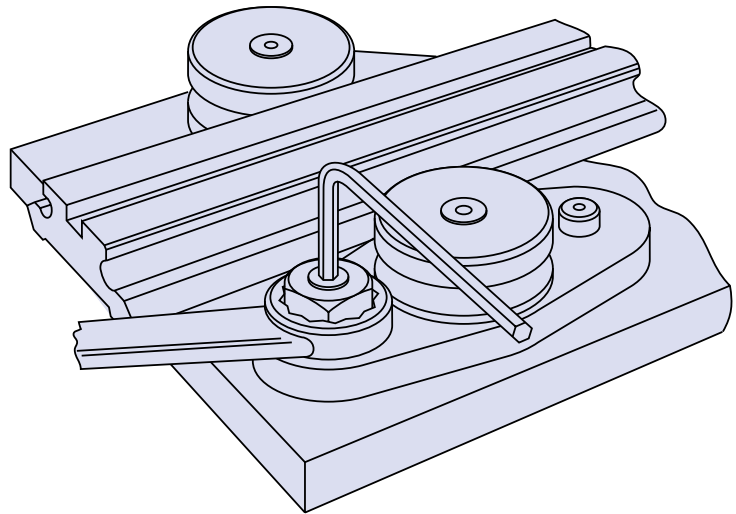

Cap Seal Assembly and Adjustment

Fitting of the Cap Seals should be carried out after the Bearing Assembly adjustment has been completed. To fit the Cap Seals over the bearings, the Carriage plate should be removed from the Slide, then the Cap seals loosely assembled to the Carriage Plate by means of the screws provided.

The Carriage may then be returned to the Slide and each Cap Seal adjusted in, to just make contact with the Slide 'V' surface until smearing of the lubricant is observed whilst operating.

Greater sealing effect, at the expense of increased friction, may be achieved by adjusting each Cap Seal body in further until its 'V' profile makes contact with the 'V' profile of the Slide.

The fixing screws should be fully tightened and each Cap Seal charged with a No. 2 Lithium soap based grease.

Male grease connector, Part No. CSCHF 4034 or complete gun is available from Hepco if required.

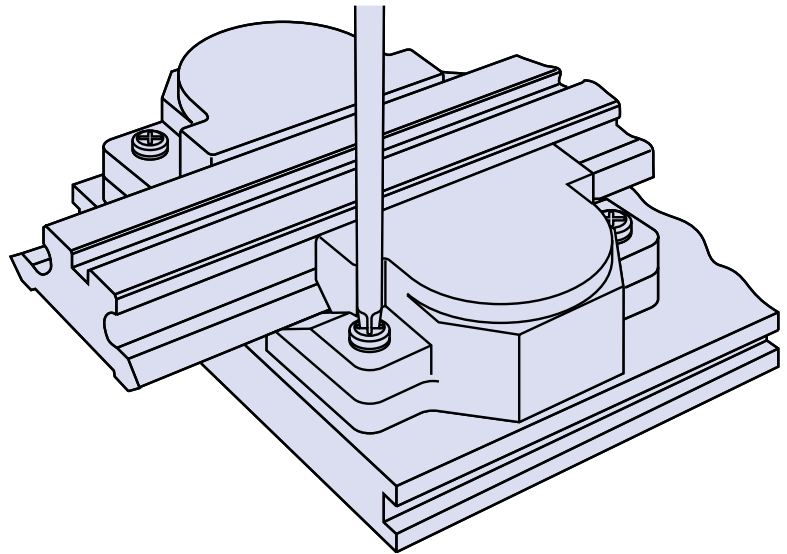

Bearing Assembly Adjusting Tools and Tightening Torques

When ordering individual components for the first time, Bearing Assembly Adjusting Tools should also be ordered - these are only available from Hepco.

Bearing Assembly Type	SS SJ/LJ 13	SS SJ/LJ 25	SS SJ/LJ 34	SS SJ/LJ 54
Adjusting Wrench	AT12	AT25	AT34	AT54
Socket Tool	-	RT8	RT10	RT14
Fixing Nut Torque	2Nm	18Nm	33Nm	90Nm

Deflection of Self-Supporting Slides

When SL2 System Slides are used as self-supporting beams (in conjunction with Hepco Flange Clamps - see page 17) in the construction of machines, the Slides will deflect under load. Care should be taken when designing an installation to take account of this deflection, choosing a Slide section which will give both adequate life and satisfactory stiffness for the duty.

The deflection of a Slide beam across a span (as shown opposite), will be a maximum at the centre of the span when the load passes over this point. This maximum deflection is given by the following equation:

$$(1) \quad d = \frac{FL^3}{48EI}$$

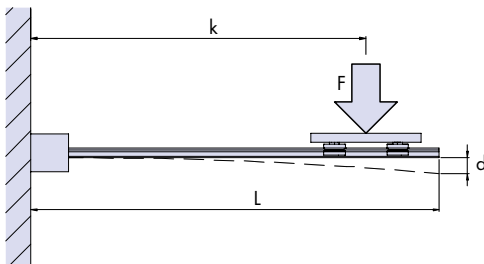
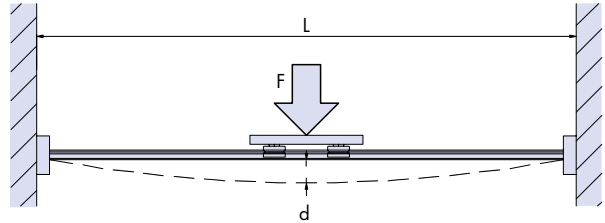

The deflection of a Slide beam acting as a cantilever and using a Long Flange Clamp (as shown opposite), will be a maximum at the free end when the load is at the outermost extremity of its stroke. This maximum deflection is given by the following equation:

$$(2) \quad d = \frac{FL^2(3L - k)}{6EI} + FLkRc$$

In the equations (1) and (2) above, L, k and d are the dimensions shown in the relevant diagrams (in mm) and F is the load applied in Newtons. The term Rc is a constant relating to the stiffness of the Flange Clamp, and EI is the product of the material's Young's modulus and the section moment of inertia, which is a constant relating to the stiffness of the Slide section in the orientation of the application*. These constants are given for the various systems in the table below.

Slide Section	EI horizontal*	EI vertical*	Rc
SSNS25	4.2×10^8	1.2×10^9	1.3×10^{-7}
SSNM44	1.3×10^9	9.0×10^9	4.0×10^{-8}
SSNL76	1.1×10^{10}	7.0×10^{10}	1.4×10^{-8}

* The orientation refers to the plane of the Slide which is resisting the bending forces applied. See figure opposite.

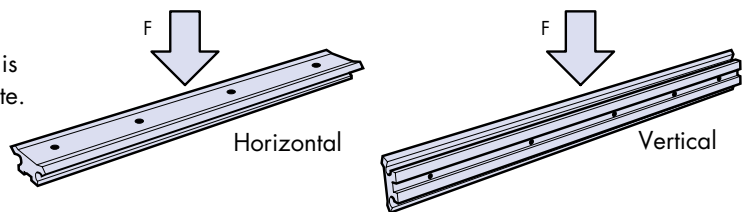

Example 1

SS NM 44 Slide used across a span with the load acting on the horizontal plane. Uses two SS SFC 44 Flange Clamps. F = 700N, L = 600mm. From equation (1), deflection is:

$$\frac{700 \times 600^3}{48 \times 1.3 \times 10^9} = 2.4\text{mm}$$

Example 2

SS NL 76 Slide used in a cantilever application with the load acting on the horizontal plane. Uses one SS LFC 76 Flange Clamp. F = 1500N, L = 350mm, k = 250mm. From equation (2), deflection is:

$$\frac{1500 \times 350^2 \times (3 \times 350 - 250)}{6 \times 1.1 \times 10^{10}} + 1500 \times 350 \times 250 \times 1.4 \times 10^{-8} = 4.1\text{mm}$$

Notes:

1. The deflections calculated are for static loadings, in some situations dynamic loading may increase the amount of bend.
2. Slide beam installations will be stiffer with the Slide orientated so that the widest section resists bending. Care should be taken in such applications to ensure that offset loads do not cause excessive bending in the weaker perpendicular plane.

Technical Specifications

Slideways

Material and Finish:	Special martensitic Stainless Steel conforming generally to AISI 420 series, ground on all main surfaces to N5.
Hardness of 'V' surface:	Generally 52 HRC
Straightness:	Generally 0.2mm/m unmounted (see note below)
Parallelism:	'V' and datum faces 0.013mm/m non-accumulative
Hole Pitch Tolerance:	± 0.1mm non-accumulative

Bearing Assemblies

Bearing Raceways and Balls:	Stainless Steel AISI 440C
Hardness:	58-62 HRC
Seals:	Nitrile rubber
Cage:	Plastic
Studs:	Stainless Steel AISI 303
BHJ 'E' Baseplate:	Stainless Steel AISI 316
Temperature Range:	-20°C to +120°C
Grease:	Lithium soap grease NLGI 2

Carriage Plate

Material:	High Strength Aluminium Alloy
Finish:	U.S. Department of Agriculture approved surface treatment

Cap Seal

Material:	Body: Thermoplastic elastomer Inserts: Impact resistant plastic Wipers: Felt
Temperature Range:	-20°C to +60°C

Lubricator

Material:	Impact resistant plastic with felt wiper
Temperature Range:	-20°C to +60°C

Flange Clamp

Material:	High Strength Aluminium Alloy
Finish:	U.S. Department of Agriculture approved surface treatment

Fixing Screws, Nuts and Washers

Material:	Stainless Steel grades AISI 304 or 316
-----------	--

Counterbore Plugs

Material:	Plastic
-----------	---------

Frictional Resistance

Coefficient of friction (without Cap Seals or Lubricators) = 0.02	
Cap Seals and Lubricators add friction as follows:	
4 Cap Seals per Carriage	SSCS25 = 7N, SSCS34 = 15N, SSCS54 = 28N
2 Lubricators per Carriage	SSLB13 = 1N, SSLB25 = 2.5N
	SSLB34 = 3N, SSLB54 = 4N

External Lubrication

Cap Seals should be lubricated with EP grease NLGI consistency No. 2
Lubricators should be oiled using EP oil. Food compatible lubricants can also be used.

Maximum Linear Speeds

Lubricated = 5 metres per second, depending upon duty and environmental conditions.

Note: The straightness figure quoted above for Slides is for the unmounted condition. Slides can be set straight during the assembly process.

HepcoMotion® Product Range



GV3
Linear Guidance and
Transmission System

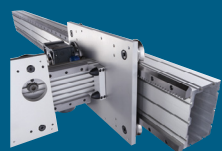

HDS2
Heavy Duty
Slide System

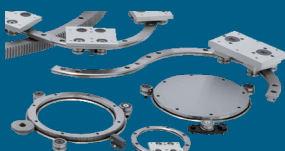

PRT2
Precision Ring
and Track System



HDRT
Heavy Duty Ring Slides
and Track System

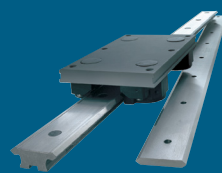

SL2
Stainless Steel Based
Slide System

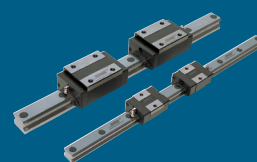

LBG
Linear Ball Guides

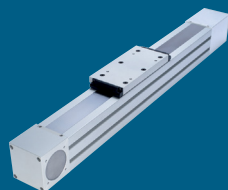

SBD
Sealed Belt
Drive



MCS
Aluminium Frame
and Machine
Construction System

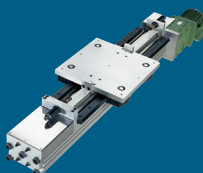

HDLS
Heavy Duty Driven
Linear System

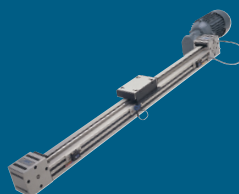

DLS
Linear Transmission and
Positioning System

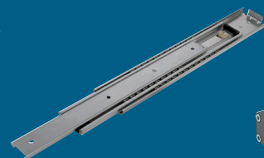

HTS
Telescopic Ball
Bearing Slides



HPS
Powerslide-2 Guided
Rodless Cylinder

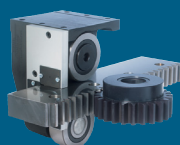

MHD
Heavy Duty Track Roller
Guidance System

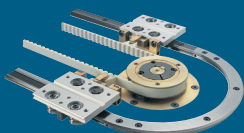

DTS
Driven Track System



BSP
Ballscrew Premier

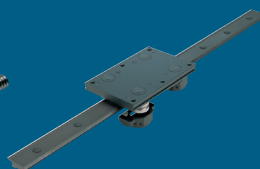

Simple Select®
Vee Slide Linear
Guidance Systems

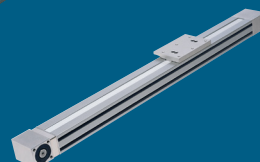

PDU2
Profile Driven Unit

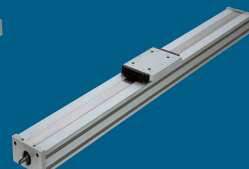

PSD120
Profile Screw Driven Unit

BishopWisecarver Product Range

HepcoMotion® – Exclusive European partners and distributors for Bishop-Wisecarver since 1984.

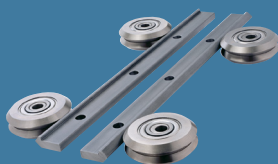

DUALVEE®
Single Edge Slide System

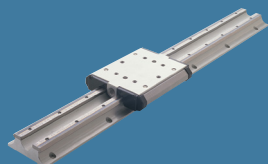

LoPro®
Aluminium Based
Slide System

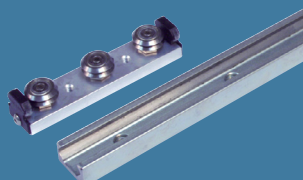

Utilitrak®
Lightweight U Channel
Guideway

For further information on HepcoMotion® products –
please request our leaflet 'FPL'

HepcoMotion®

www.HepcoMotion.com



INVESTOR IN PEOPLE



Lower Moor Business Park, Tiverton Way, Tiverton, Devon, England EX16 6TG
Tel: +44 (0)1884 257000 Fax: +44 (0)1884 243500
sales@hepcotion.com

CATALOGUE No. SL2 06 UK © 2012 Hepco Slide Systems Ltd.

Reproduction in whole or part without prior authorisation from Hepco is prohibited. Although every effort has been made to ensure the accuracy of the information in this catalogue, Hepco cannot accept liability for any omissions or errors. Hepco reserves the right to make alterations to the product resulting from technical developments. Many Hepco products are protected by: Patents, Copyright, Design Right or Registered Design. Infringement is strictly prohibited and may be challenged in law. The Customer's attention is drawn to the following clause in Hepco's conditions of sale: 'It shall be the Customer's sole responsibility to ensure that goods supplied by Hepco will be suitable or fit for any particular application or purpose of the Customer, whether or not such application or purpose is known to Hepco. The Customer will be solely responsible for any errors in, or omissions from, any specifications or information the Customer provides. Hepco will not be obliged to verify whether any such specifications or information are correct or sufficient for any application or purpose.' Hepco's full conditions of sale are available on request and will apply to all quotations and contracts for the supply of items detailed in this catalogue.



Scan this QR code to link directly to the HepcoMotion® homepage.

HepcoMotion is the trading name of Hepco Slide Systems Ltd.