

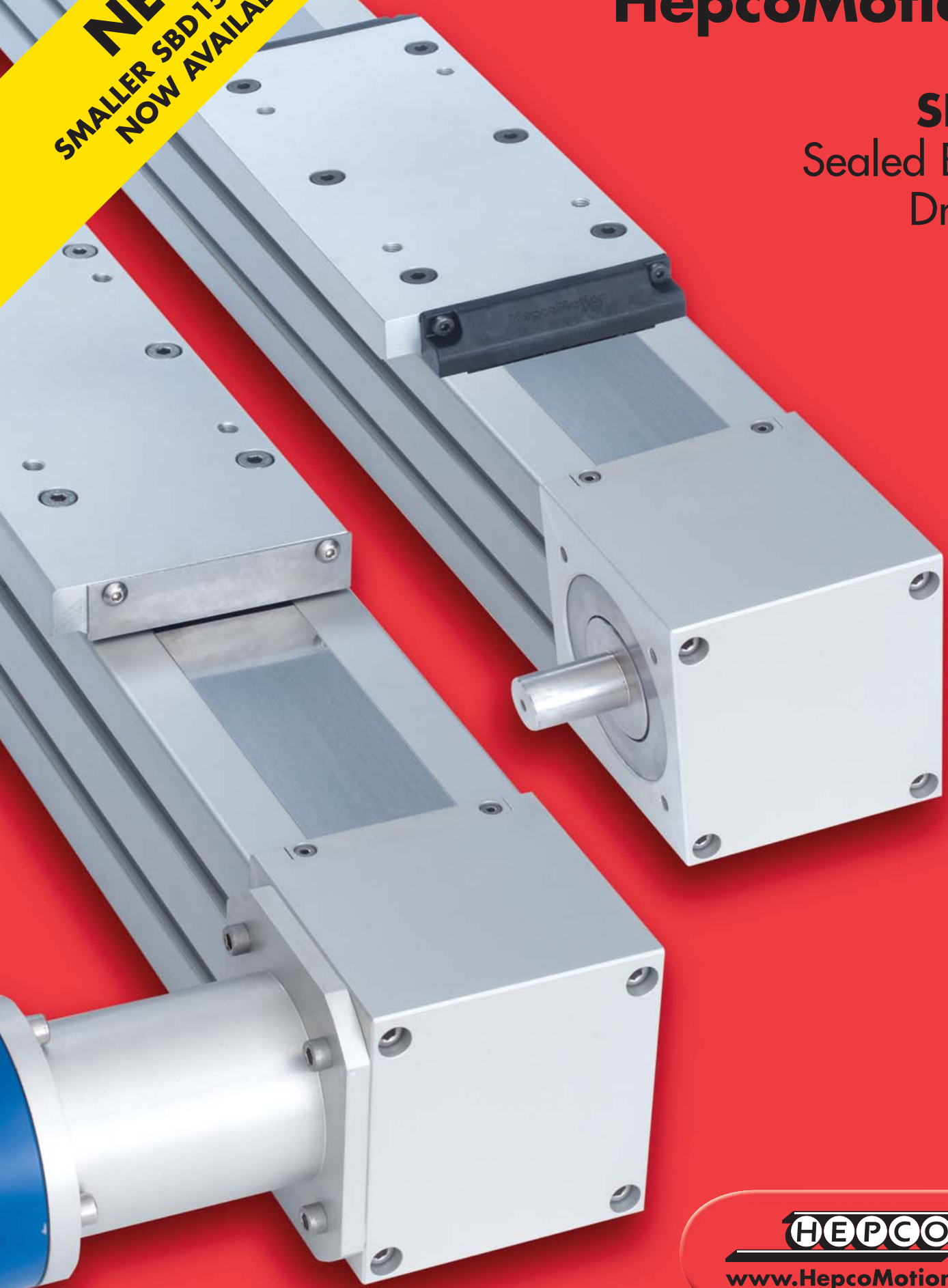

**NEW**  
SMALLER SBD15-60 SIZE  
NOW AVAILABLE

**HepcoMotion®**

**SBD**  
Sealed Belt  
Drive



## Introduction

The HepcoMotion SBD is an exceptionally rugged, quiet and precise linear unit. It uses super-smooth Hepco LBG caged linear ball guides having such high load capacity that system life is rarely an issue. Drive is provided by a new high strength tooth belt. The unit is housed in an anodised aluminium beam and is completely enclosed with a stainless steel cover to provide excellent protection from dirt and debris. A corrosion resistant version with all external components made in stainless steel or anodised aluminium is an option. A version for use in high specification cleanrooms is also available  5-6.

### Stainless Steel Cover

- Helps protect internal mechanism from ingress of debris
- Effective in any orientation
- Enhances safety and appearance

### Removable Carriage Plate

- Easily detachable for customising
- Can be rotated 180° to change handing of switch cam

### Mounting Platform

- Tapped holes for ease of component attachment
- Direct fixing of multi-axis mounting brackets

### Limit Switch & Bracket

- Mechanical and inductive versions
- IP67 rating
- Easily adjustable

### Aluminium Beam

- Available up to 6 metres in one piece
- Stiff self supporting beam may form part of machine construction
- 6 T-slots for ease of mounting
- T-slot compatible with Hepco MCS and other profiles
- T-nuts, T-slot covers, mounting brackets & multi-axis connection brackets available

### Drive Shaft

- Supplied with fitted key
- Right, left, double & hollow shaft options (right hand shown)
- Motor connection kits available

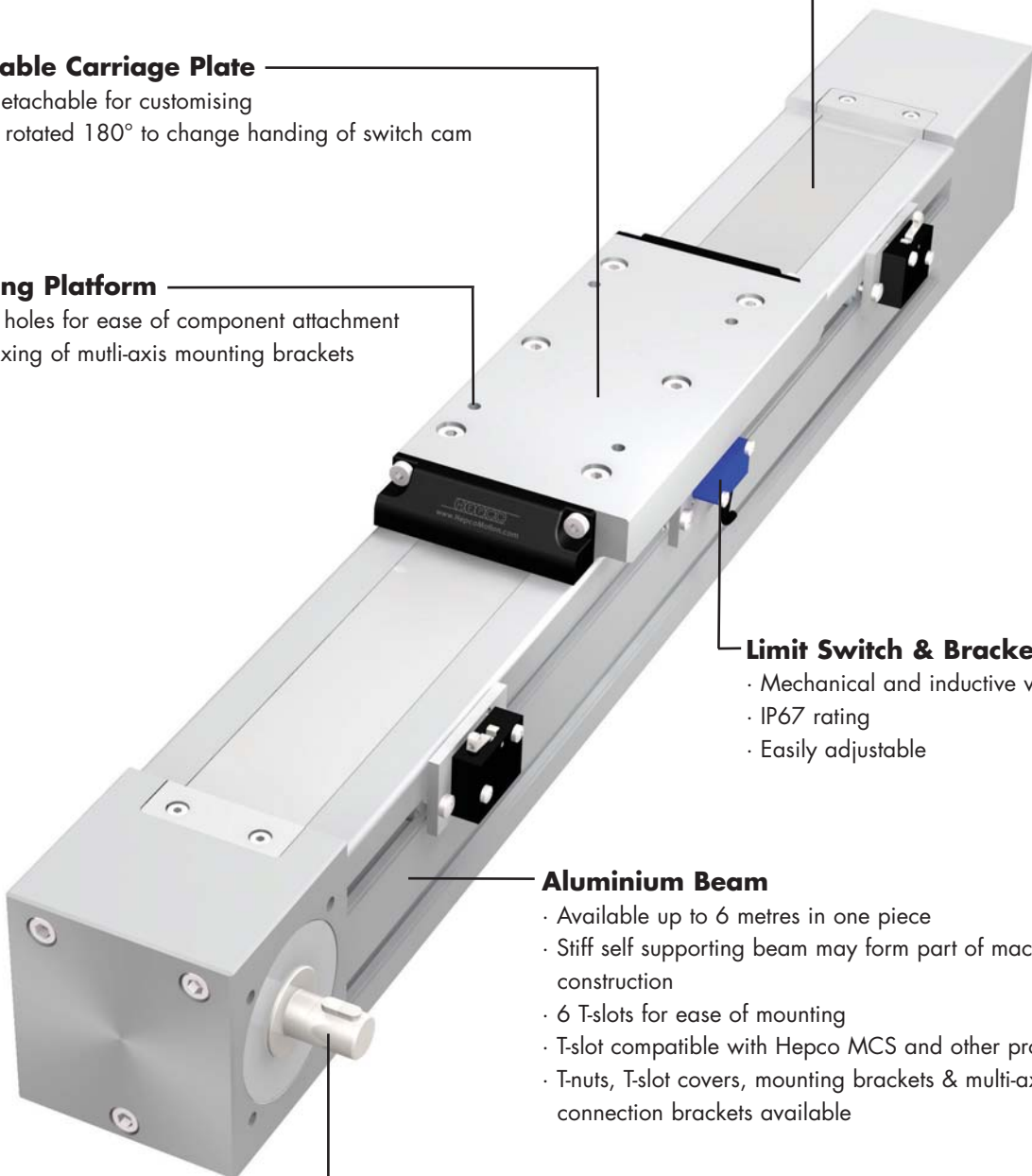

## System Composition

SBD units are available in lengths up to 6m in one piece and unlimited lengths can be achieved with joined beams. Units are factory adjusted and lubricated. Re-lubrication of the linear ball guide is easily achieved via an access hole in the beam. SBD units are suitable for single or multi-axis applications and can be supplied with a wide range of gearboxes, motors and drives. The beam profiles and T-slots are compatible with Hepco's MCS frame building system and its extensive range of accessories, allowing complete machines to be built.

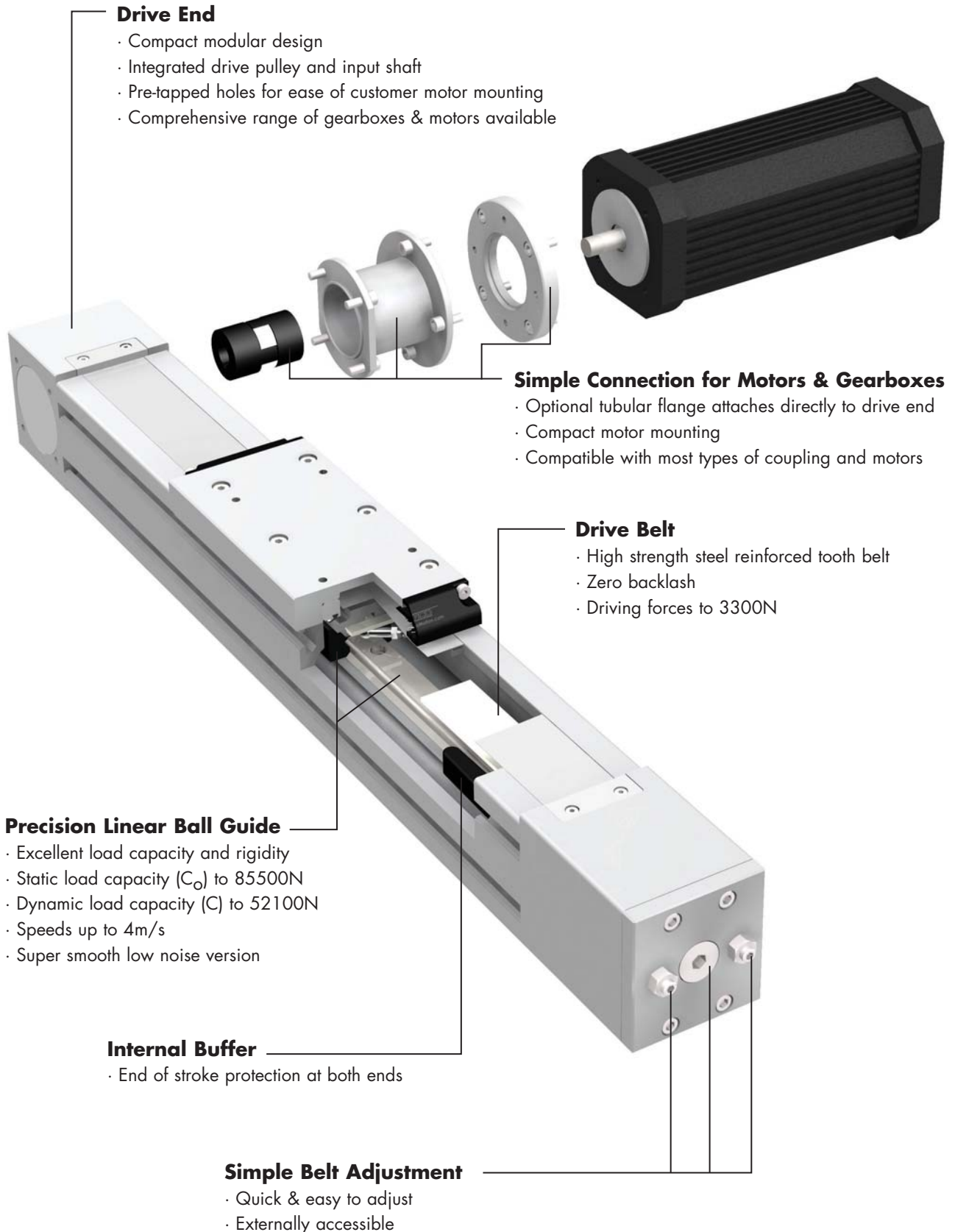

## Data & Dimensions

The main dimensions of the SBD unit are shown below. Further details can be obtained from the 3D CAD files available from Hepco's technical department or at [www.HepcoMotion.com](http://www.HepcoMotion.com). Units are supplied in increments of 60mm (SBD20-80) and 80mm (SBD30-100) up to 6000mm in one piece  $\geq 10$ . Longer units are made from more than one piece. The nominal stroke length is calculated with the carriage against the internal buffers. In practice a clearance should be provided to allow for overrun.

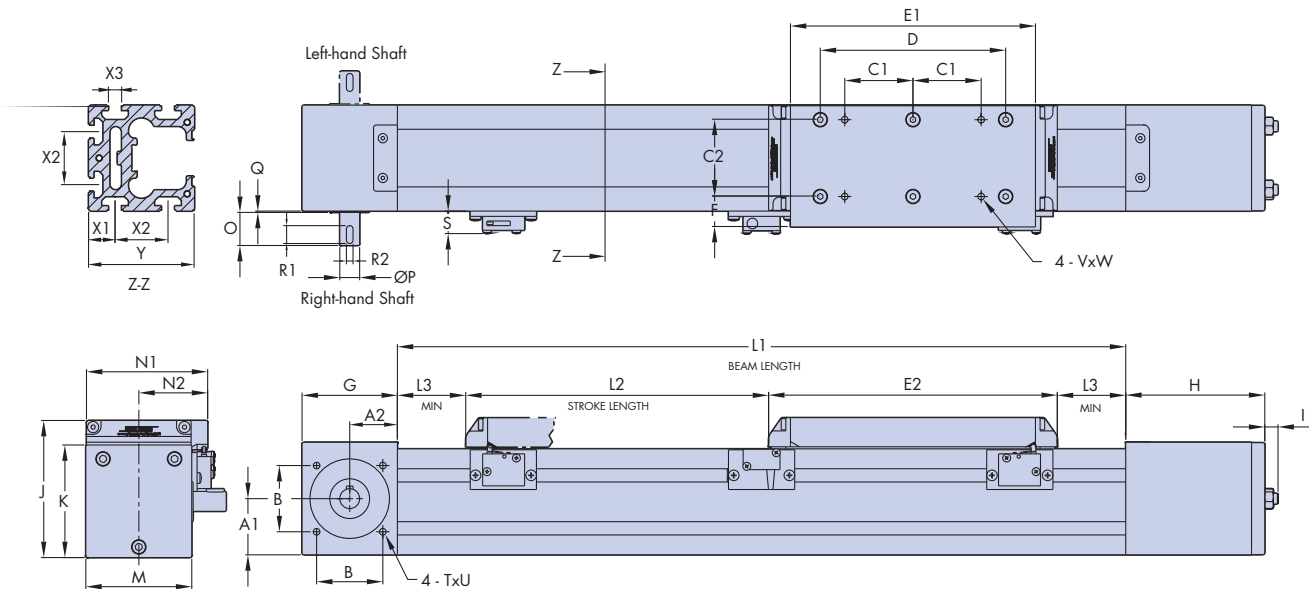

SBD Unit	A1	A2	B	C1	C2	D	E1	E2	F	G	H	I	J	K	L1 (min)	L2 Nominal Stroke	L3 (min)
SBD20-80	42.4	36	50	51.5	58	140	185	218	23	72	105	12	103.5	85	550	L1 - 300	41
SBD30-100	51.6	48	65	65	76	180	235	268	24.5	96	145.5	13	123.5	105	580	L1 - 365	48.5

SBD Unit	M	N1	N2	O	P	Q	R1	R2	S	TxU	VxW	X1	X2	X3	Y
SBD20-80	80	91.5	52	25	15	1	13.5	5	17	M6 x 15	M6 x 9.5	20	40	10	80
SBD30-100	100	112	62.5	36	20	1	22	6	17	M6 x 15	M8 x 9.5	30	40	10	100

All dimensions in mm

Re-lubrication of the ball guide carriage block is via an access point in the side of the beam (see below), which is closed off with a threaded plug. The lubrication interval depends on length of stroke, speed and duty. Contact Hepco's technical department for further details.

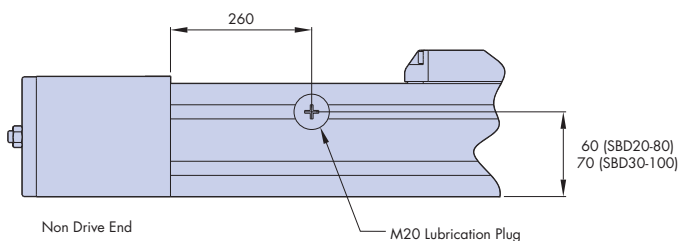

## Drive Connections

The HepcoMotion SBD can be supplied with a fitted motor or gearbox to suit many different applications. Connection to other motors and gearboxes is quick and simple using one of the fixing kits. Standard kits to suit a range of servo motor frame sizes 036, 056 & 071 are stock items. Hepco can offer a fast service on special connection kits for attachment of customer's motors and gearboxes. Hepco can supply AC motors, stepper and servo systems including braked motors, encoders and inverter drives for power and control. Please contact Hepco for full details and application advice. A typical servo motor arrangement is shown in the illustration below.

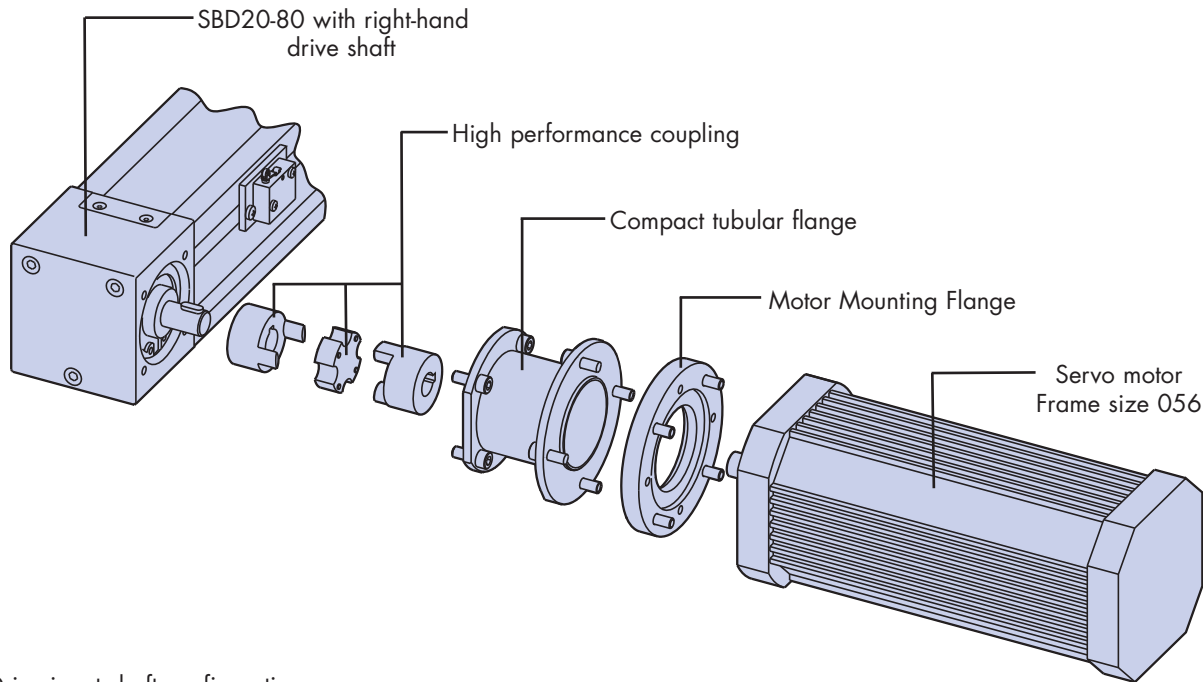

### Drive input shaft configurations

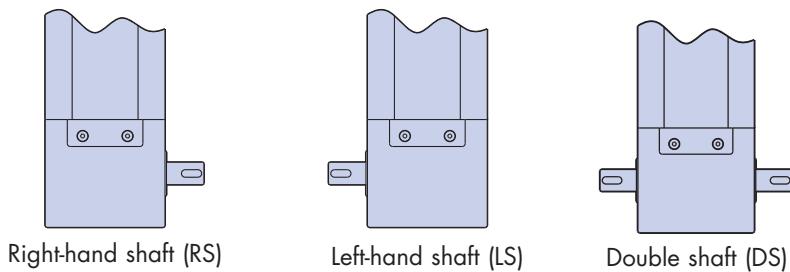

The hollow shafted arrangement may offer a more compact and lower cost means of retro-fitting a motor and/or gearbox onto an SBD. For further details of motor connections please visit [www.HepcoMotion.com/sbddatauk](http://www.HepcoMotion.com/sbddatauk) and select datasheet No. 1 SBD motor connections.

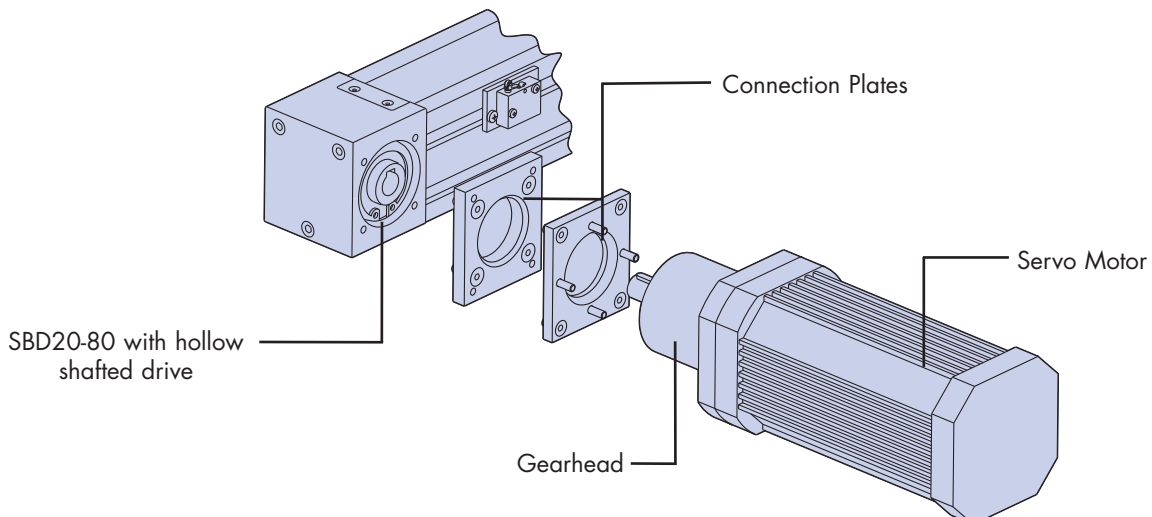

## Cleanroom Version

The cleanroom version of the SBD unit has been designed to meet an increasing demand for clean manufacturing processes and environments. This version of the SBD unit is ready for connection to vacuum extraction which minimises particle emissions. All external parts are made from anodised aluminium or stainless steel. This SBD cleanroom unit is certified by the Fraunhofer IPA Institute for use in cleanroom environments and meets air cleanliness class 3 according to ISO 14644-1. For further details please visit [www.HepcoMotion.com/sbddatauk](http://www.HepcoMotion.com/sbddatauk) and select datasheet No. 5 cleanroom qualification.



### Drive Shaft

- Stainless steel shaft with fitted key
- Right, left, double and hollow shaft options
- Motor connection kits available

### Stainless Steel Cover

- Effective in any orientation
- Enhances safety and appearance

### Removable Carriage Plate

- Easily detachable for customising
- Can be rotated 180° to change handing of switch cam

### Mounting Platform

- Tapped holes for ease of component attachment
- Direct fixing of multi-axis mounting brackets

### T-Slots

- For T-nut attachment
- Optional covers prevent debris traps

### Lubrication Point

- Stainless steel blanking plug

### Vacuum Connection

- Tapped vacuum connection holes
- Can be supplied fitted with vacuum connectors
- May be moved or deleted on request

### Aluminium Beam

- Available up to 6 metres in one piece
- Clear anodised finish
- 6 T-slots compatible with Hepco MCS and other profiles
- T-nuts, mounting brackets & multi-axis connection brackets available

### Stainless Steel Fasteners

- All external fasteners are stainless steel

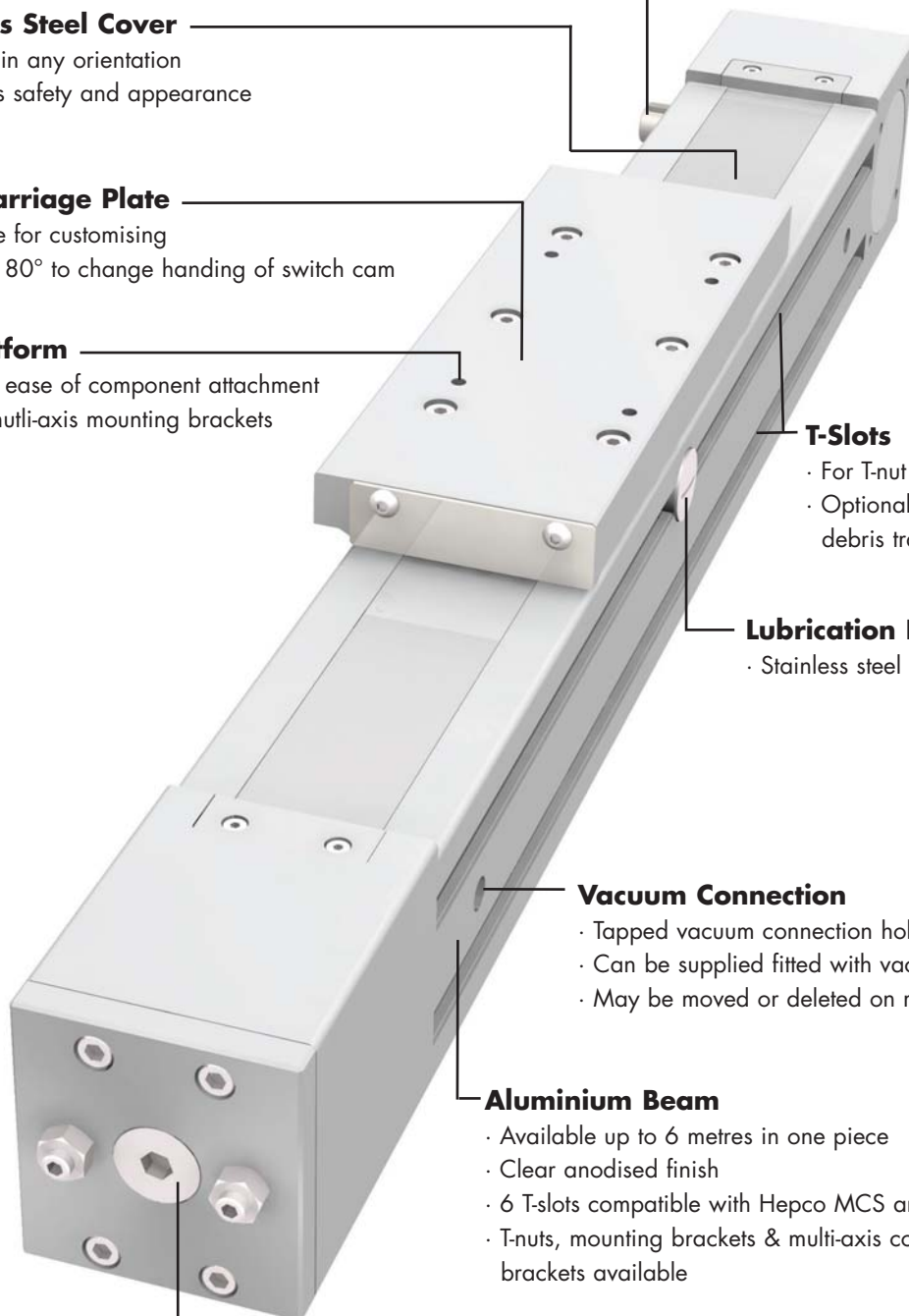

## Data & Dimensions

The main dimensions of the SBD cleanroom version are shown in the table below. Further details can be obtained from the 3D CAD files available from Hepco's technical department or at [www.HepcoMotion.com](http://www.HepcoMotion.com). Units are supplied in increments of 60mm (SBD20-80) and 80mm (SBD30-100) up to 6000mm in one piece  $\leq 10$ . Longer units are made from more than one piece. The nominal stroke length is calculated with the carriage against the internal buffers. In practice a clearance should be provided to allow for overrun.

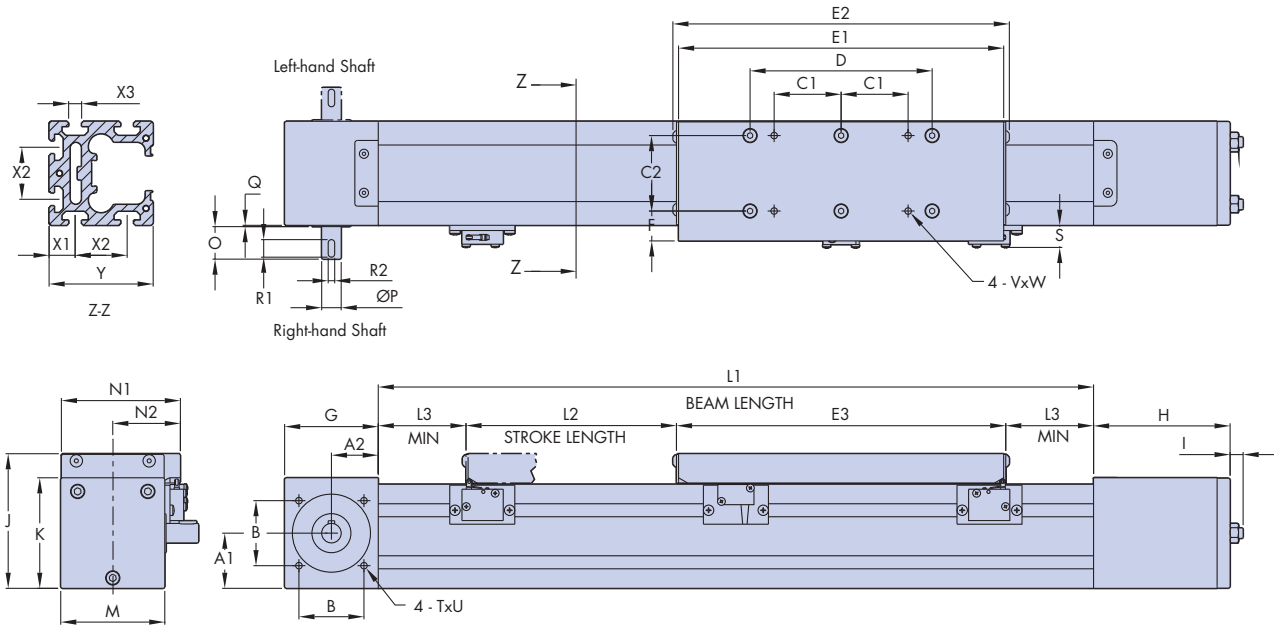

SBD Unit	A1	A2	B	C1	C2	D	E1	E2	E3	F	G	H	I	J	K	L1 (min)	L2 Nominal Stroke	L3 (min)
SBD20-80	42.4	36	50	51.5	58	140	250	259	253	23	72	105	12	103.5	85	550	L1 - 300	23.5
SBD30-100	51.6	48	65	65	76	180	300	309	303	24.5	96	145.5	13	123.5	105	580	L1 - 365	31

SBD Unit	M	N1	N2	O	P	Q	R1	R2	S	T x U	V x W	X1	X2	X3	Y
SBD20-80	80	91.5	52	25	15	1	13.5	5	17	M6 x 15	M6 x 9.5	20	40	10	80
SBD30-100	100	112	62.5	36	20	1	22	6	17	M6 x 15	M8 x 9.5	30	40	10	100

All dimensions in mm

The vacuum extraction connection hole positions together with the lubrication access plug are shown below. Hepco can supply vacuum connections pre-fitted on request. Vacuum holes can be repositioned to suit customer requirements or deleted.

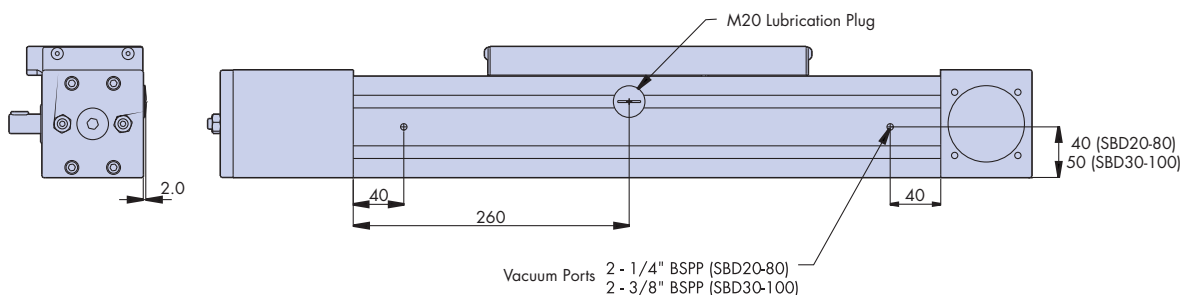

## Axis Connections

The HepcoMotion SBD design allows for easy construction of multi-axis systems onto Hepco MCS and other frames and machine elements. A comprehensive range of mounting kits and accessories is available. Some typical system configurations are shown below to illustrate the versatility of the SBD design. Connection components have been identified together with their part numbers for ease of selection. Hepco's technical department can assist with application enquiries or undertake the design of multi-axis systems.

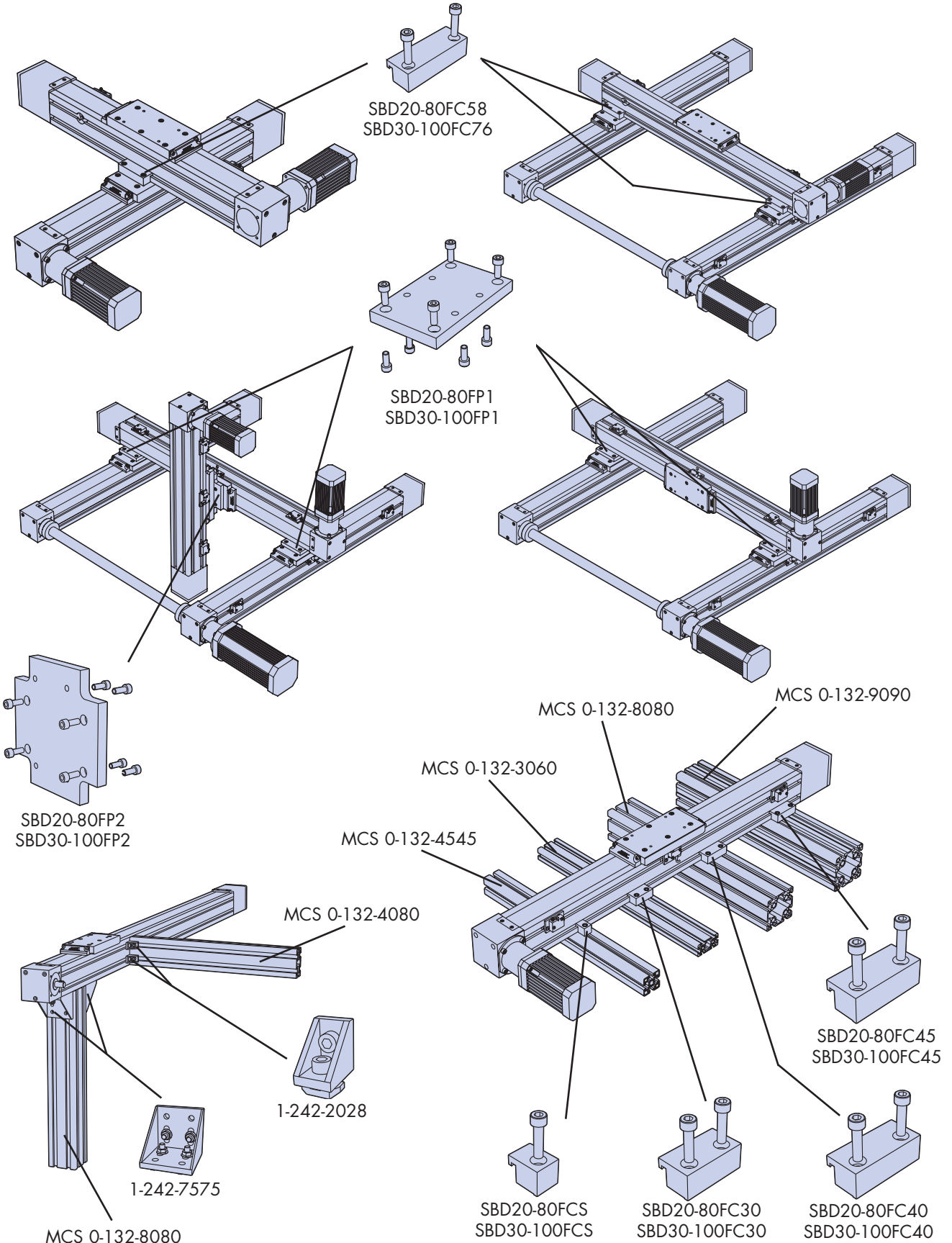



## Load & Life Calculations

The nominal load capacities for the SBD (based on LBG ball guide dynamic load capacity) and a typical load corresponding to 10 000km\* travel are included in the table below for each of the 5 direct and moment loading directions.

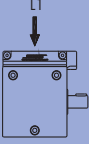
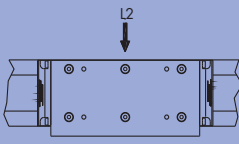
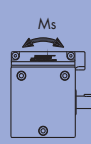
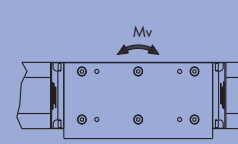
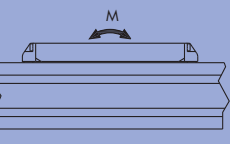
SBD Unit					
SBD20-80	21200N nominal 1813N @ 10 000km	21200N nominal 1813N @ 10 000km	189Nm nominal 16.2Nm @ 10 000km	175Nm nominal 14.9Nm @ 10 000km	175Nm nominal 14.9Nm @ 10 000km
SBD30-100	52100N nominal 4455N @ 10 000km	52100N nominal 4455N @ 10 000km	639Nm nominal 54Nm @ 10 000km	755Nm nominal 64Nm @ 10 000km	755Nm nominal 64Nm @ 10 000km

\* The tabulated load figures above for 10 000km assume a value for variable load factor  $f_v = 2$  which is suitable for most applications.

To calculate the life of an SBD unit, first calculate the load factor  $L_f$  using the equation below:

$$L_f = \frac{L_1}{L_{1(max)}} + \frac{L_2}{L_{2(max)}} + \frac{M_s}{M_{s(max)}} + \frac{M}{M_{(max)}} + \frac{M_v}{M_{v(max)}} \leq 0.2$$

The life of the system is then calculated using the equation below:

$$\text{System Life (km)} = 50 \times \left( \frac{1}{L_f \times f_v} \right)^3$$

Note:  $f_v$  is the variable load factor which takes account of speed and vibration/impact conditions. A value of 2 is appropriate for typical SBD applications, but consult Hepco for specific advice. For further guidance on load life calculations please visit [www.HepcoMotion.com/sbddatauk](http://www.HepcoMotion.com/sbddatauk) and select datasheet No. 2 SBD load life calculations.

## Technical Data

The table below includes the parameters necessary to calculate the performance and duty of an SBD system.

Parameter			SBD20-80		SBD30-100	
			Standard	Cleanroom	Standard	Cleanroom
Mass of carriage	Mc	kg	1.4	1.6	3.6	3.9
Mass of belt per m	Mb	kg/m	0.12		0.34	
Mass of SBD unit	Mu	kg	9.7 x L + 6.0	9.7 x L + 6.2	15.7 x L + 12.2	15.7 x L + 12.5
Pulley radius	r	cm	2.39		3.5	
Drive efficiency			0.9		0.9	
Break away friction	Fba	N	25	10	35	25
Coefficient of friction	$\mu$		0.01		0.01	
Beam moment of inertia*	$I_{x-x}$	mm <sup>4</sup>	1500000		3700000	
	$I_{y-y}$		1800000		4600000	
Max linear force (belt)	Fmax	N	1000		3300	
Linear movement per shaft rev		mm	150		220	
Belt tooth pitch		mm	5		10	
LBG carriage basic load rating (dynamic)	C	N	21200		52100	

\* The beam moment of inertia figure is used in the calculation of beam deflection, with a high figure corresponding to a stiff beam. For further guidance on beam deflection calculations please visit [www.HepcoMotion.com/sbddatauk](http://www.HepcoMotion.com/sbddatauk) and select datasheet No. 3 SBD beam deflection calculations.

## Ancillary Components

Limit switch assembly includes mechanical switch, bracket, fixing screws and T-nuts.

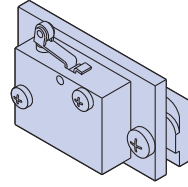

SBD20-80-V3SWA-M  
SBD30-100-V3SWA-M

Limit switch assembly includes inductive switch, bracket, fixing screws and T-nuts.

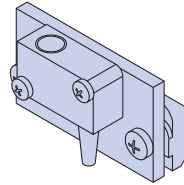

SBD20-80-V3SWA-I  
SBD30-100-V3SWA-I

Plastic T-slot cover supplied fitted in each of the T-slots in the beam.

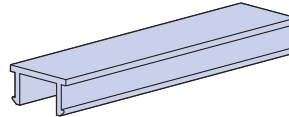

1-242-1016

The quick fit type T-nut can be inserted into T-slot and rotated through 90° to engage. T-nuts are available threaded M4, M5, M6 and M8.

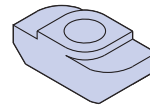

M4 = 1-242-1029  
M5 = 1-242-1030  
M6 = 1-242-1001  
M8 = 1-242-1002

Drive shafts in a number of sizes and designs are available. Contact Hepco for details.

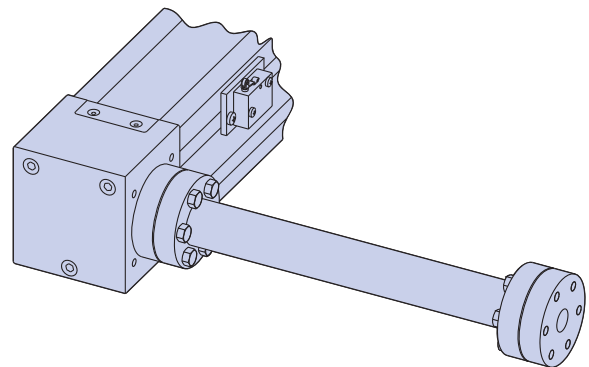

## Ordering Details

The ordering information below is given to assist communication, but you are recommended to discuss your application with Hepco first so that we can help to specify the best unit configuration to suit your needs. A step-by-step SBD enquiry form is available please visit [www.HepcoMotion.com/sbdatauk](http://www.HepcoMotion.com/sbdatauk) and select datasheet No. 4 SBD enquiry form.

### Main Unit

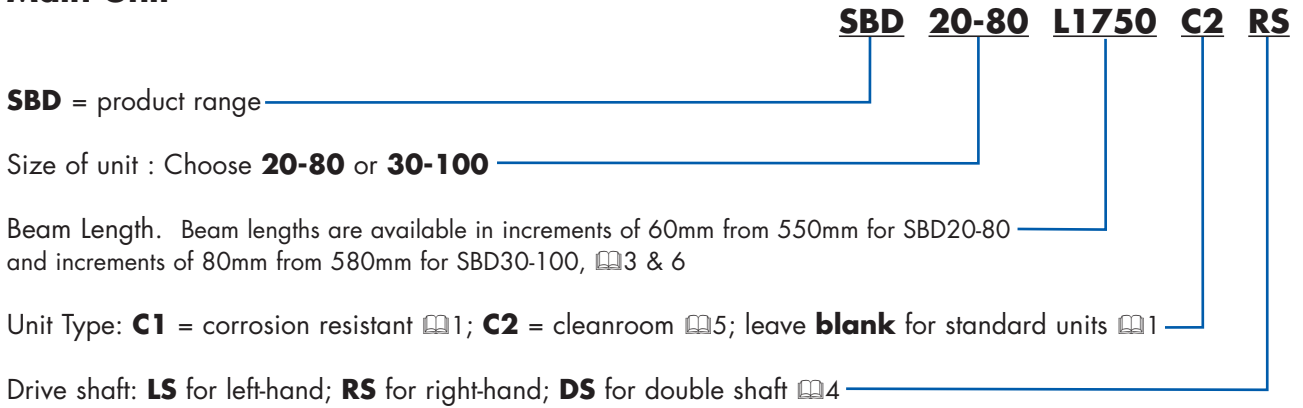

### Notes

[www.HepcoMotion.com](http://www.HepcoMotion.com)

# SBD Long Carriage Option

SBD units in both standard and cleanroom versions are available with a long carriage option. This version has two LBG bearing blocks in the carriage and has much improved load capacity, particularly in M & Mv directions. The main dimensions of the standard long carriage SBD units are shown below. Further details can be obtained from the 3D CAD files available from Hepco's technical department or at [www.HepcoMotion.com](http://www.HepcoMotion.com). Standard & cleanroom units are supplied in increments of 60mm (SBD20-80) and 80mm (SBD30-100) up to 6000mm. Longer units are made from more than one piece. The nominal stroke length is calculated with the carriage against the internal buffers. In practice a clearance should be provided to allow for overrun. Re-lubrication of the ball guide carriage blocks is via two access points in the side of the beam (see below), and closed off with a threaded plug. The lubrication interval depends on length of stroke, speed and duty, contact Hepco's technical department for further details.

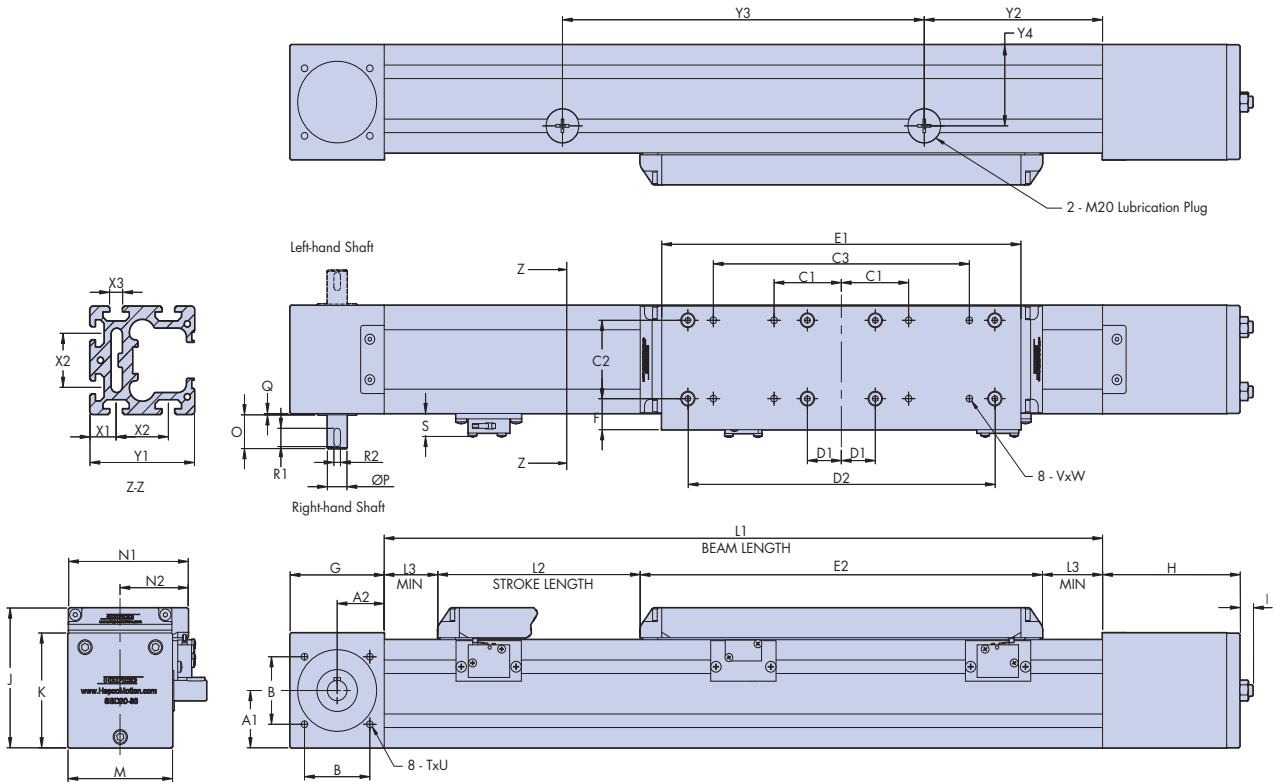

SBD Unit	A1	A2	B	C1	C2	C3	D1	D2	E1	E2	F	G	H	I	J	K	L1 (min)	L2 Nominal Stroke	L3 (min)
SBD20-80	42.4	36	50	51.5	58	196	26	235	275	308	23	72	105	12	103.5	85	550	L1 - 390	41
SBD30-100	51.6	48	65	65	76	260	46	295	340	373	24.5	96	145.5	13	123.5	105	580	L1 - 470	48.5

SBD Unit	M	N1	N2	O	P	Q	R1	R2	S	TxU	VxW	X1	X2	X3	Y1	Y2	Y3	Y4
SBD20-80	80	91.5	52	25	15	1	13.5	5	17	M6 x 15	M6 x 9.5	20	40	10	80	162.5	225	60
SBD30-100	100	112	62.5	36	20	1	22	6	17	M6 x 15	M8 x 9.5	30	40	10	100	164	252.5	70

# SBD Long Carriage Option

The cleanroom version of the SBD unit has been designed to meet an increasing demand for clean manufacturing processes and environments. This version of the SBD unit is ready for connection to vacuum extraction which minimises particle emissions. All external parts are made from anodised aluminium or stainless steel. This SBD cleanroom unit is certified by the Fraunhofer IPA Institute for use in cleanroom environments and meets air cleanliness class 3 according to ISO 14644-1. For further details please visit [www.HepcoMotion.com/sbddatauk](http://www.HepcoMotion.com/sbddatauk) and select datasheet No. 5 cleanroom qualification. The main dimensions of the cleanroom long carriage SBD units are shown below. Further details can be obtained from the 3D CAD files available from Hepco's technical department or at [www.HepcoMotion.com](http://www.HepcoMotion.com).

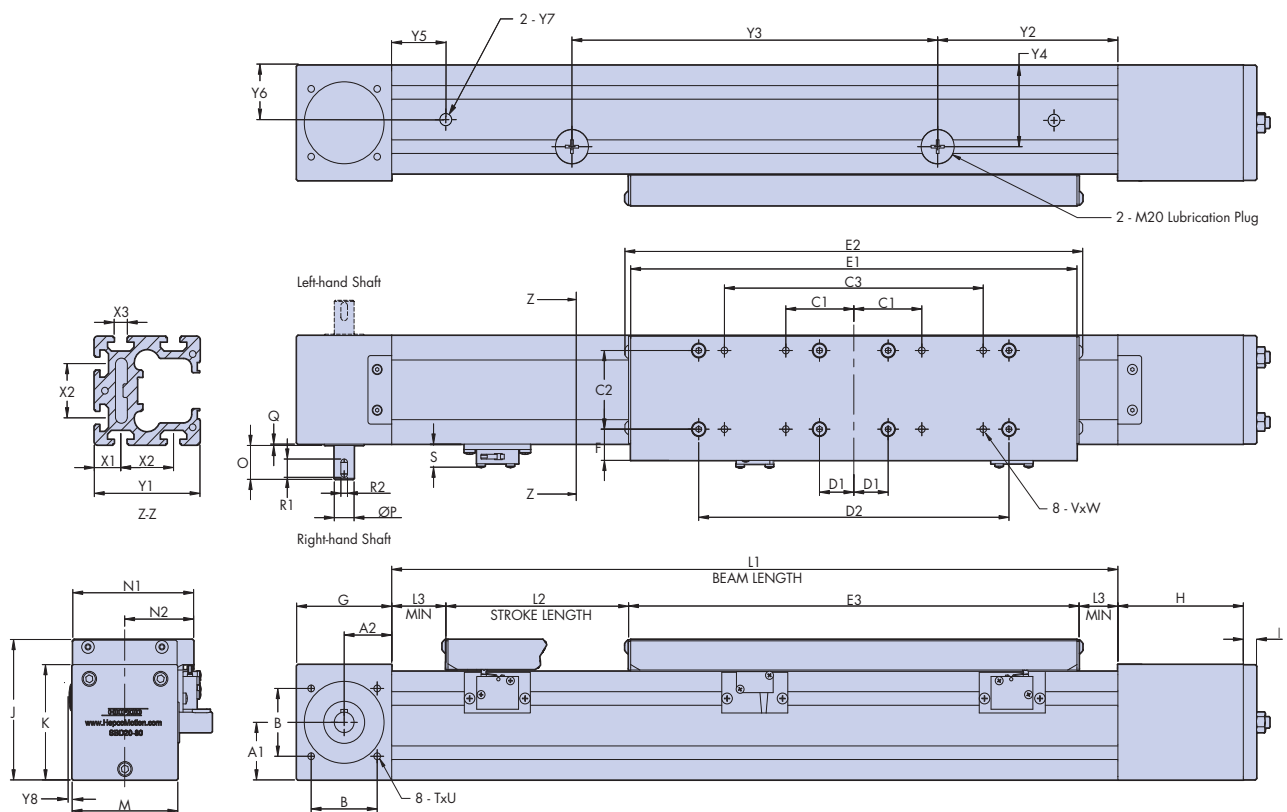
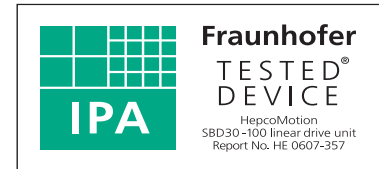

SBD Unit	A1	A2	B	C1	C2	C3	D1	D2	E1	E2	E3	F	G	H	I	J	K	L1 (min)	L2 Nominal Stroke	L3 (min)
SBD20-80	42.4	36	50	51.5	58	196	26	235	338	347	341	23	72	105	12	103.5	85	550	L1 - 390	24.5
SBD30-100	51.6	48	65	65	76	260	46	295	404	413	407	24.5	96	145.5	13	123.5	105	580	L1 - 470	31.5

SBD Unit	M	N1	N2	O	P	Q	R1	R2	S	TxU	VxW	X1	X2	X3	Y1	Y2	Y3	Y4	Y5	Y6	Y7	Y8
SBD20-80	80	91.5	52	25	15	1	13.5	5	17	M6 x 15	M6 x 9.5	20	40	10	80	162.5	225	60	40	40	1/4" BSPP	2
SBD30-100	100	112	62.5	36	20	1	22	6	17	M6 x 15	M8 x 9.5	30	40	10	100	164	252.5	70	40	50	3/8" BSPP	2

The vacuum extraction connection holes (see dimensions Y5 & Y6) can be repositioned to suit customer requirements or deleted. Hepco can supply vacuum connections pre-fitted on request.

## Technical Data

The nominal load capacities for the SBD long carriage units are based on LBG ball guide dynamic load capacities combined with a mounting factor of 0.8 (see LBG catalogue 19). They are shown in the table below for each of the 5 direct and moment loading directions. For guidance on load life calculations please refer to the SBD catalogue 8 and visit [www.HepcoMotion.com/sbdatauk](http://www.HepcoMotion.com/sbdatauk) and select datasheet No.2 load life calculations.

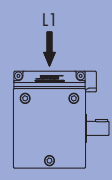
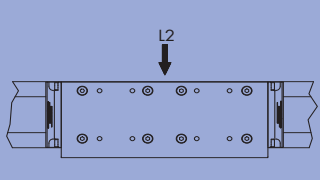
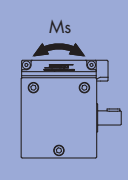
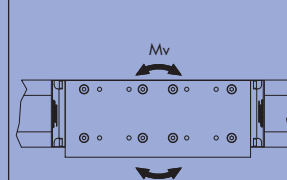
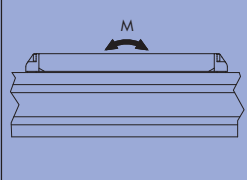
SBD Unit					
SBD20-80	33920N	33920N	302Nm	1611Nm	1150Nm
SBD30-100	68800N	68800N	848Nm	4214Nm	2990Nm

The table below includes the parameters necessary to calculate the performance and duty of an SBD system.

Parameter			SBD20-80		SBD30-100	
			Standard	Cleanroom	Standard	Cleanroom
Mass of carriage	Mc	kg	2.3	2.5	5.2	5.5
Mass of belt per m	Mb	kg/m	0.12		0.34	
Mass of SBD unit	Mu	kg	9.7 x L + 6.9	9.7 x L + 7.2	15.7 x L + 13.7	15.7 x L + 14.0
Pulley radius	r	cm	2.39		3.5	
Drive efficiency			0.9		0.9	
Break away friction	Fba	N	29	14	46	36
Coefficient of friction	$\mu$		0.01		0.01	
Beam moment of inertia*	$I_{x-x}$	mm <sup>4</sup>	1500000		3700000	
	$I_{y-y}$		1800000		4600000	
Max linear force (belt)	Fmax	N	1000		3300	
Linear movement per shaft rev		mm	150		220	
Belt tooth pitch		mm	5		10	
LBG carriage basic load rating (dynamic)	C	N	33920		68800	

\* The beam moment of inertia figure is used in the calculation of beam deflection, with a high figure corresponding to a stiff beam. For further guidance on beam deflection calculations please visit [www.HepcoMotion.com/sbdatauk](http://www.HepcoMotion.com/sbdatauk) and select datasheet No. 3 SBD beam deflection calculations.

### Ordering Details

**SBD 20-80 L1750 C2 RS B2**

**SBD** = product range \_\_\_\_\_

Size of unit: Choose **20-80** or **30-100** \_\_\_\_\_

Beam Length. Beams lengths available in increments of 60mm from 550mm for SBD20-80 and increments of 80mm from 580mm for SBD30-100, see \_\_\_\_\_

Unit type: **C1** = corrosion resistant; **C2** = cleanroom; leave **blank** for standard unit \_\_\_\_\_

Drive shaft: **LS** for left-hand; **RS** for right-hand; **DS** for double shaft \_\_\_\_\_

Long carriage option with twin LBG bearing blocks: **B2** \_\_\_\_\_

# SBD 15-60

The HepcoMotion® SBD 15-60 is a new smaller addition to the SBD range of linear actuators. It shares the key features and benefits of the existing SBD range, but using a HepcoMotion LBC15 Linear Ball Guide. Units are supplied in increments of 60mm up to 6000mm in one piece, and unlimited lengths can be achieved with joined beams. The nominal stroke is calculated with the carriage against the internal buffers. In practice a clearance should be provided to allow for overrun. The main dimensions of the standard unit are shown below. Further details can be obtained from Hepco's technical department.

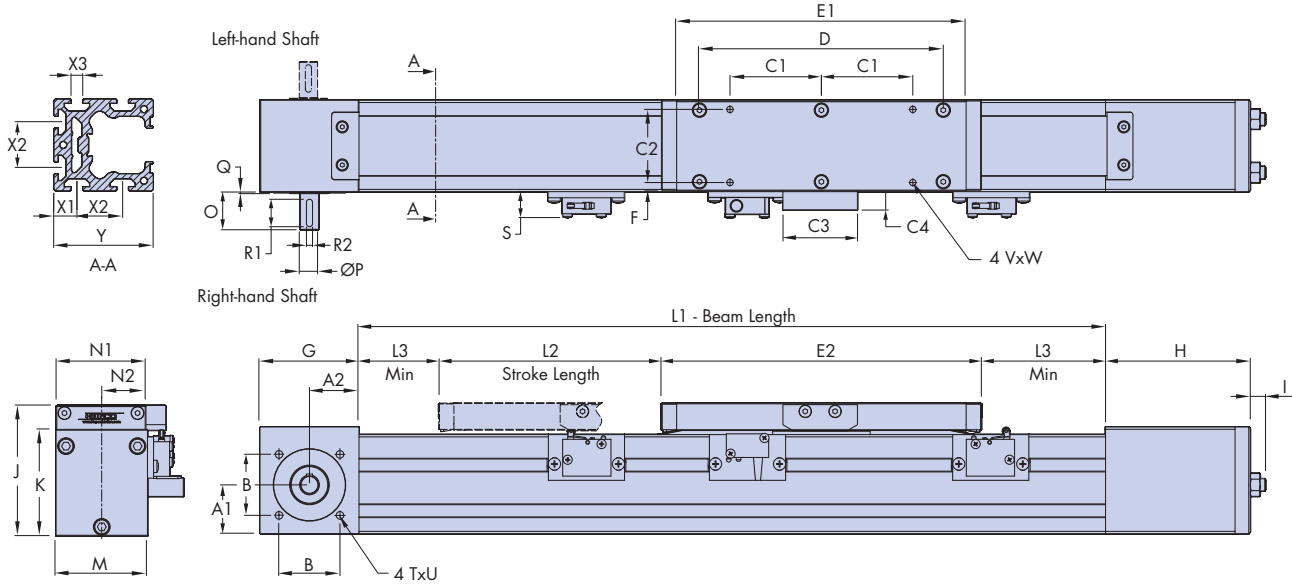

SBD Unit	A1	A2	B	C1	C2	C3	C4	D	E1	E2	F	G	H	I	J	K	L1 (min)	L2 Nominal stroke	L3 (min)
SBD15-60	32	33	41	60	48	50	12.5	150	180	200	5.5	65	95	11	84	70	550	L1-240	20

SBD Unit	M	N1	N2	O	P	Q	R1	R2	S	TxU	VxW	X1	X2	X3	Y	Y2	Y3	Y4
SBD15-60	60	59	29.5	25	12	1	18	4	17	M5x10	M5x8	15	30	8	65	250	43	M15

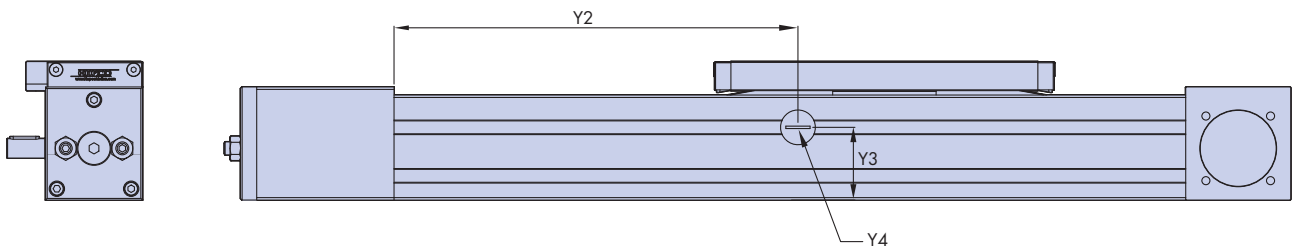

Re-lubrication of the ball guide carriage block is via an access point in the side of the beam (see above), which is closed off with a threaded plug. The lubrication interval depends on the length of stroke, speed and duty. For further details regarding lubrication procedures please contact Hepco's technical department.

# SBD15-60 - Long Carriage Option

The SBD15-60 unit is available with a long carriage version, this option has two LBG bearing blocks in the carriage and has much improved load capacity particularly in the M & Mv directions. The main dimensions of the long carriage units are shown below. Further details can be obtained from Hepco's technical department.

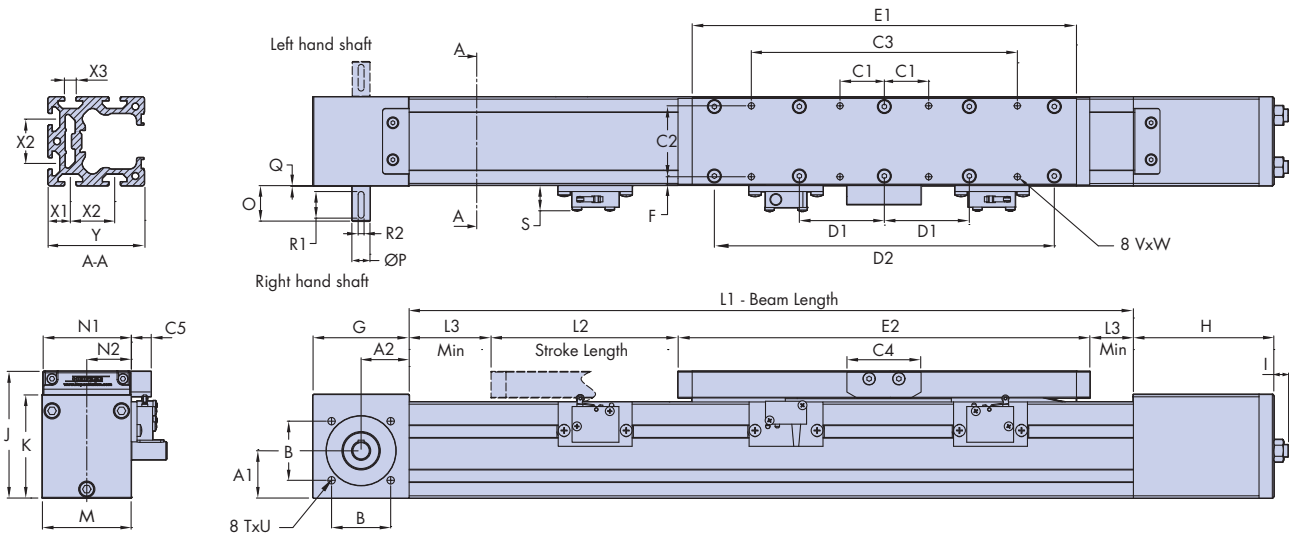

SBD Unit	A1	A2	B	C1	C2	C3	C4	C5	D1	D2	E1	E2	F	G	H	I	J	K	L1 (min)	L2 Nominal stroke	L3 (min)
SBD15-60	32	33	41	30	48	180	50	12.5	57.5	220	250	270	5.5	65	95	11	84	70	550	L1-310	20

SBD Unit	M	N1	N2	O	P	Q	R1	R2	S	TxU	VxW	X1	X2	X3	Y	Y1	Y2	Y3
SBD15-60	60	59	29.5	25	12	1	18	4	17	M5x10	M5x8	15	30	8	65	250	158	43

(All dimensions in mm)

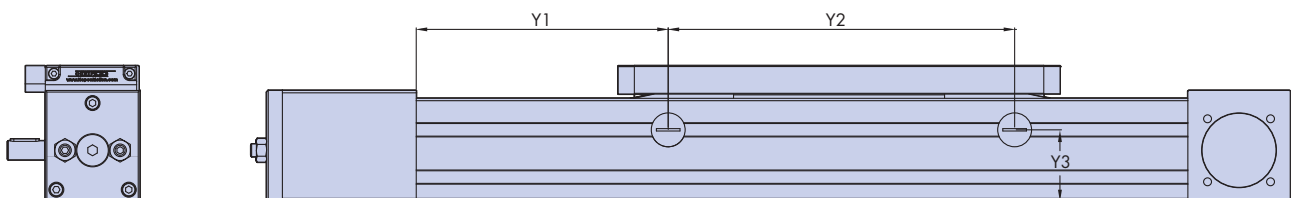

Re-lubrication of the ball guide carriage blocks is via two access points in the side of the beam (see above), and closed off with a threaded plug. The lubrication interval depends on length of stroke, speed and duty. For further details regarding lubrication procedures please contact Hepco's technical department.



# Technical Information

The nominal load capacities for the SBD (based on LBG ball guide dynamic load capacity) and a typical load corresponding to 10 000km\*<sup>1</sup> travel are included in the table below for each of the 5 direct and moment loading directions\*<sup>2</sup>.

SBD Unit					
SBD15-60	8500N nominal (13600N) 726 @ 10 000km	8500N nominal (13600N) 726N @ 10 000km	52Nm nominal (82Nm) 4.4Nm @ 10 000km	41Nm nominal (350Nm) 3.5Nm @ 10 000km	41Nm nominal (350Nm) 3.5Nm @ 10 000km

(Figures shown in brackets relate to the long carriage version.)

The table below includes the parameters necessary to calculate the performance and duty of the SBD system.

Parameter			SBD15-60	SBD15-60
			Standard	Long Carriage
Mass of carriage	Mc	kg	0.8	1.3
Mass of belt per m	Mb	kg/m	0.09	0.09
Mass of SBD unit	Mu	kg	5.5 x L + 2.9	5.5 x L + 3.4
Pulley radius	r	cm	1.91	1.91
Drive efficiency			0.9	0.9
Break away friction	Fba	N	24	28
Coefficient of friction	μ		0.01	0.01
Beam moment of inertia* <sup>3</sup>	I <sub>x-x</sub>	mm <sup>4</sup>	560000	560000
	I <sub>y-y</sub>		600000	600000
Max linear force (belt)	Fmax	N	700	700
Linear movement per shaft rev		mm	120	120
Belt tooth pitch		mm	5	5
LBG carriage basic load rating (dynamic)	C	N	16500	26400

## Ordering Details

**SBD** = product range \_\_\_\_\_ **SBD 15-60 L1740 C1 RS B2**

Size of unit : **15-60** \_\_\_\_\_

Beam Length. Beam lengths are available in increments of 60mm from 550mm \_\_\_\_\_

Unit Type: **C1** = corrosion resistant; leave **blank** for standard units \_\_\_\_\_

Drive shaft: **LS** for left-hand; **RS** for right-hand; **DS** for double shaft \_\_\_\_\_

Long Carriage Option with twin LBG bearing blocks: **B2** \_\_\_\_\_

1. The tabulated load figures above for 10,000km assume a value for variable load factor  $f_v = 2$  which is suitable for most applications.
2. For load & life calculations please refer to Page 8 of the main SBD catalogue
3. The beam moment of inertia figure is used in the calculation of beam deflection, with a high figure corresponding to a stiff beam. For further guidance on beam deflection calculations please visit [www.HepcoMotion.com/sbddatauk](http://www.HepcoMotion.com/sbddatauk) and select datasheet No. 3 SBD beam deflection calculations.

[www.HepcoMotion.com](http://www.HepcoMotion.com)

[www.HepcoMotion.com](http://www.HepcoMotion.com)

# HepcoMotion® Product Range



# Bishop-Wisecarver Product Range

HepcoMotion® – Exclusive European partners and distributors for Bishop-Wisecarver since 1984.

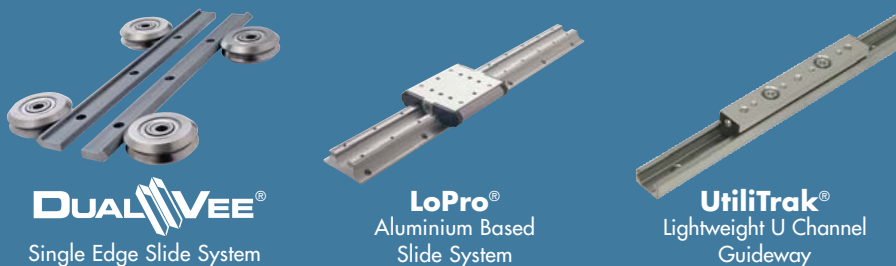

For further information on HepcoMotion® products – please request our leaflet 'FPL'



## HepcoMotion®

Lower Moor Business Park, Tiverton Way, Tiverton, Devon, England EX16 6TG  
Tel: +44 (0)1884 257000 Fax: +44 (0)1884 243500  
E-mail: [sales@hepcotion.com](mailto:sales@hepcotion.com)

CATALOGUE No. SBD 04 UK © 2010 Hepco Slide Systems Ltd.

Reproduction in whole or part without prior authorisation from Hepco is prohibited. Although every effort has been made to ensure the accuracy of the information in this catalogue, Hepco cannot accept liability for any omissions or errors. Hepco reserves the right to make alterations to the product resulting from technical developments.

Many Hepco products are protected by: Patents, Copyright, Design Right or Registered Design. Infringement is strictly prohibited and may be challenged in law. The Customer's attention is drawn to the following clause in Hepco's conditions of sale:

'It shall be the Customer's sole responsibility to ensure that goods supplied by Hepco will be suitable or fit for any particular application or purpose of the Customer, whether or not such application or purpose is known to Hepco. The Customer will be solely responsible for any errors in, or omissions from, any specifications or information the Customer provides. Hepco will not be obliged to verify whether any such specifications or information are correct or sufficient for any application or purpose.'

Hepco's full conditions of sale are available on request and will apply to all quotations and contracts for the supply of items detailed in this catalogue.

HepcoMotion is the trading name of Hepco Slide Systems Ltd.



INVESTOR IN PEOPLE

