

# The new industry benchmark...



**RK DuoLine**  
Degree of protection IP 40

# Greater reliability in automation...

...thanks to RK DuoLine, the new generation of spindles and toothed belts



Width, length and height adjustment

#### Features:

- ✓ Manual or electric drive
- ✓ Occasional to multiple adjustments daily
- ✓ Low duty cycle
- ✓ Low speed
- ✓ Medium to high stability

**RK DuoLine S spindle unit with trapezoidal screw drive**



**Move-Tec**  
continued on page 10

**Place-Tec**  
continued on page 16

**Your application  
takes  
centre stage**

**Control-Tec**  
continued on page 18



Loading and unloading,  
palletising, pick & place

**Features:**

- ✓ High repeatability
- ✓ Short cycle times
- ✓ High cycle rates
- ✓ 3 shift operation
- ✓ High reliability

**RK DuoLine Z timing-belt unit**

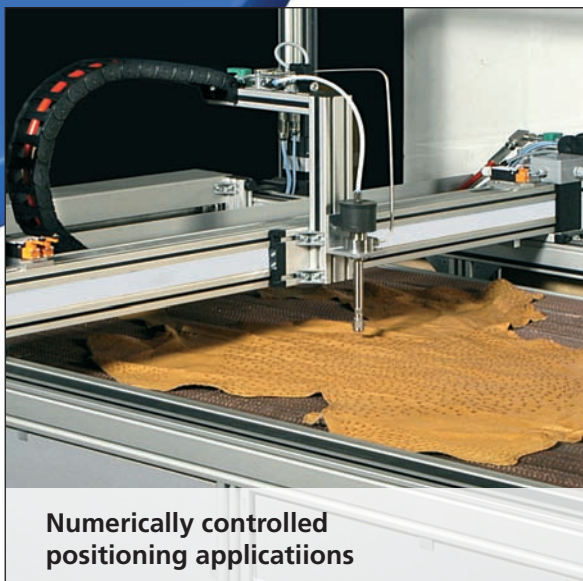

Numerically controlled  
positioning applications

**Features:**

- ✓ High positioning accuracy
- ✓ Uniform movement sequences
- ✓ High drive stiffness
- ✓ 3 shift operation
- ✓ Extremely reliable

**RK DuoLine S spindle unit  
with ball screw**



# Key features / technical benefits

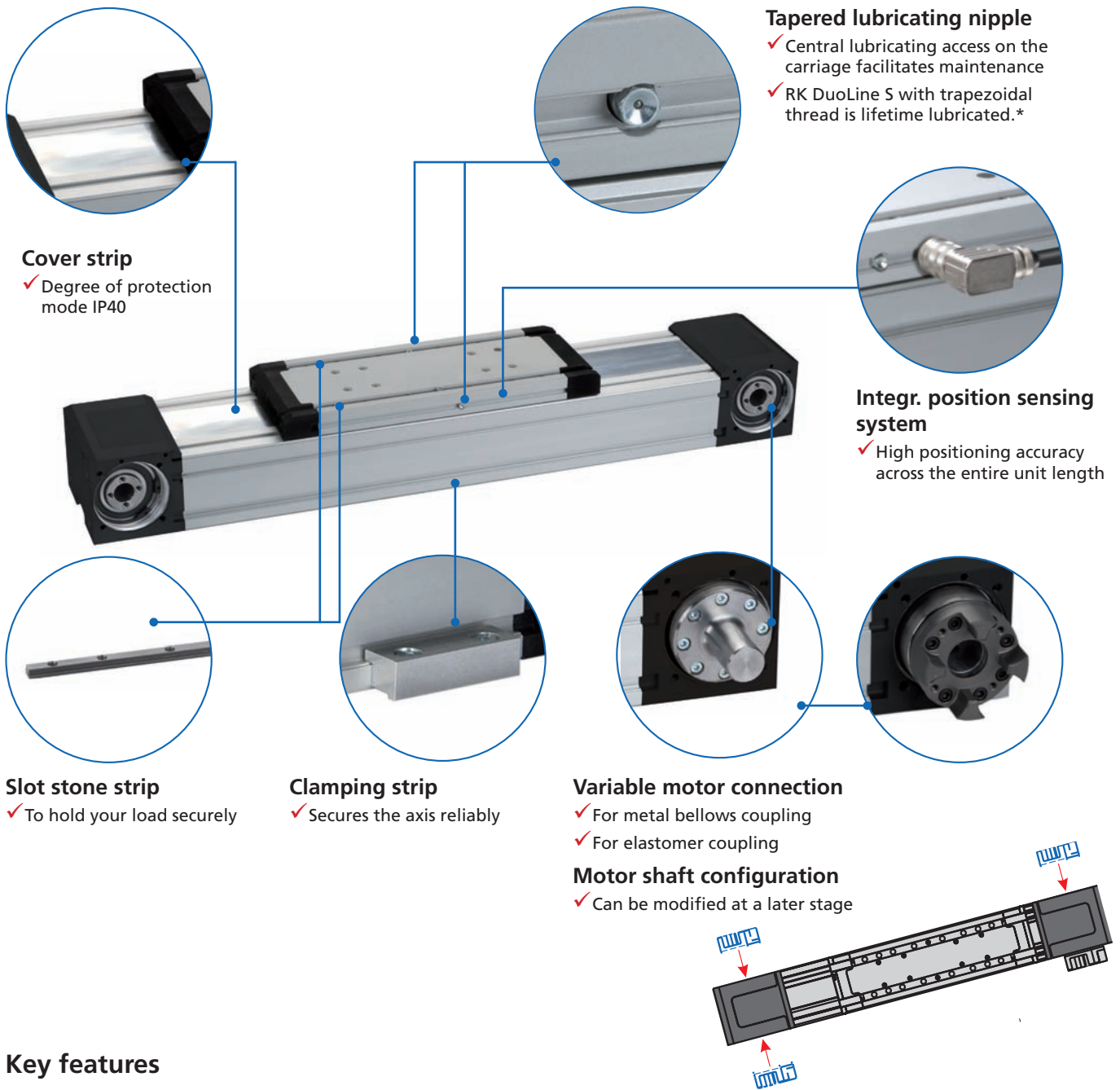

## Key features

### General

- High efficiency
- Low idle torque
- Max. usable travel speed regardless of length
- Central lubricating access on the carriage facilitates maintenance

### RK DuoLine S Protect (spindle drive)

- Degree of protection IP40 provided by steel cover strip and seals
- Positioning accuracy  $\pm 0.05$  mm when using an integrated position sensing system
- Multiple anti-vibration spindle supports

### RK DuoLine Z (toothed-belt drive)

- Degree of protection IP20
- Flexible positioning of motor thanks to pulley boxes with hollow shafts
- Repeat accuracy  $\pm 0.05$  mm

### RK DuoLine Z Protect (toothed-belt drive)

- Degree of protection IP40 provided by steel cover strip and seals
- Flexible positioning of motor thanks to pulley boxes with hollow shafts
- Repeat accuracy  $\pm 0.05$  mm

\* to around 30km running performance

## RK DuoLine - Table of contents

<b>Properties/Technical data</b>		<ul style="list-style-type: none"> <li>■ Load characteristic ..... 6</li> <li>■ General informations/operation conditions..... 7</li> </ul>
<b>Version</b> (Dimensions, order numbers)	<b>Move-Tec</b>	<ul style="list-style-type: none"> <li>■ RK DuoLine S 80 ..... 10</li> <li>■ RK DuoLine S 80 R/L ..... 12</li> </ul>
	<b>Place-Tec</b>	<ul style="list-style-type: none"> <li>■ RK DuoLine R 60/80/120..... 14</li> <li>■ RK DuoLine Z 60 ..... 16</li> <li>■ RK DuoLine Z 80..... 16</li> <li>■ RK DuoLine Z 120 ..... 16</li> <li>■ RK DuoLine Z 120 II..... 16</li> <li>■ RK DuoLine Z 160 ..... 16</li> </ul>
	<b>Control-Tec</b>	<ul style="list-style-type: none"> <li>■ RK DuoLine S 80 ..... 18</li> <li>■ RK DuoLine S 120..... 18</li> <li>■ RK DuoLine S 160 ..... 18</li> </ul>
	<b>Accessories</b>	
	<b>Fixing</b>	<ul style="list-style-type: none"> <li>■ Fixation of payload ..... 20</li> <li>■ Clamping strips ..... 21</li> <li>■ Slot stones ..... 21</li> </ul>
	<b>Drive</b>	<ul style="list-style-type: none"> <li>■ Motor adapter kit ..... 22</li> <li>■ Drive shaft ..... 23</li> <li>■ Synchronising shaft ..... 24</li> </ul>
	<b>Position determination</b>	<ul style="list-style-type: none"> <li>■ Limit switch ..... 25</li> </ul>

## Calculation of the load characteristic to define the lifetime

- The lifetime of linear units are in accordance with the average loads and moments of an application. The load characteristic can approximately calculated by following equation with simultaneously appearing load and moments.

$$\text{Load characteristic} = \frac{\text{Application values (z.B. } F_y)}{\text{Catalog values (z.B. } F_{y_{\max}})}$$

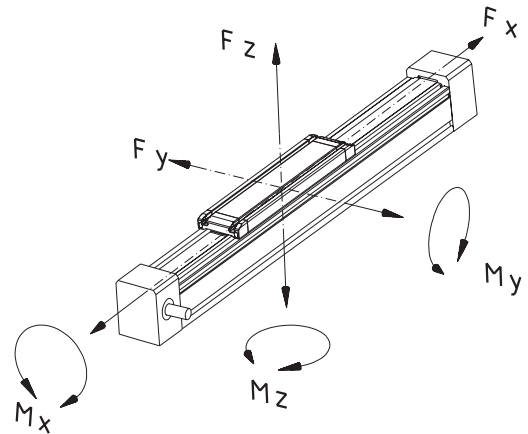

$$\text{Load characteristic } B_k = \frac{F_y}{F_{y_{\max}}} + \frac{F_z}{F_{z_{\max}}} + \frac{M_x}{M_{x_{\max}}} + \frac{M_y}{M_{y_{\max}}} + \frac{M_z}{M_{z_{\max}}} \leq 1$$

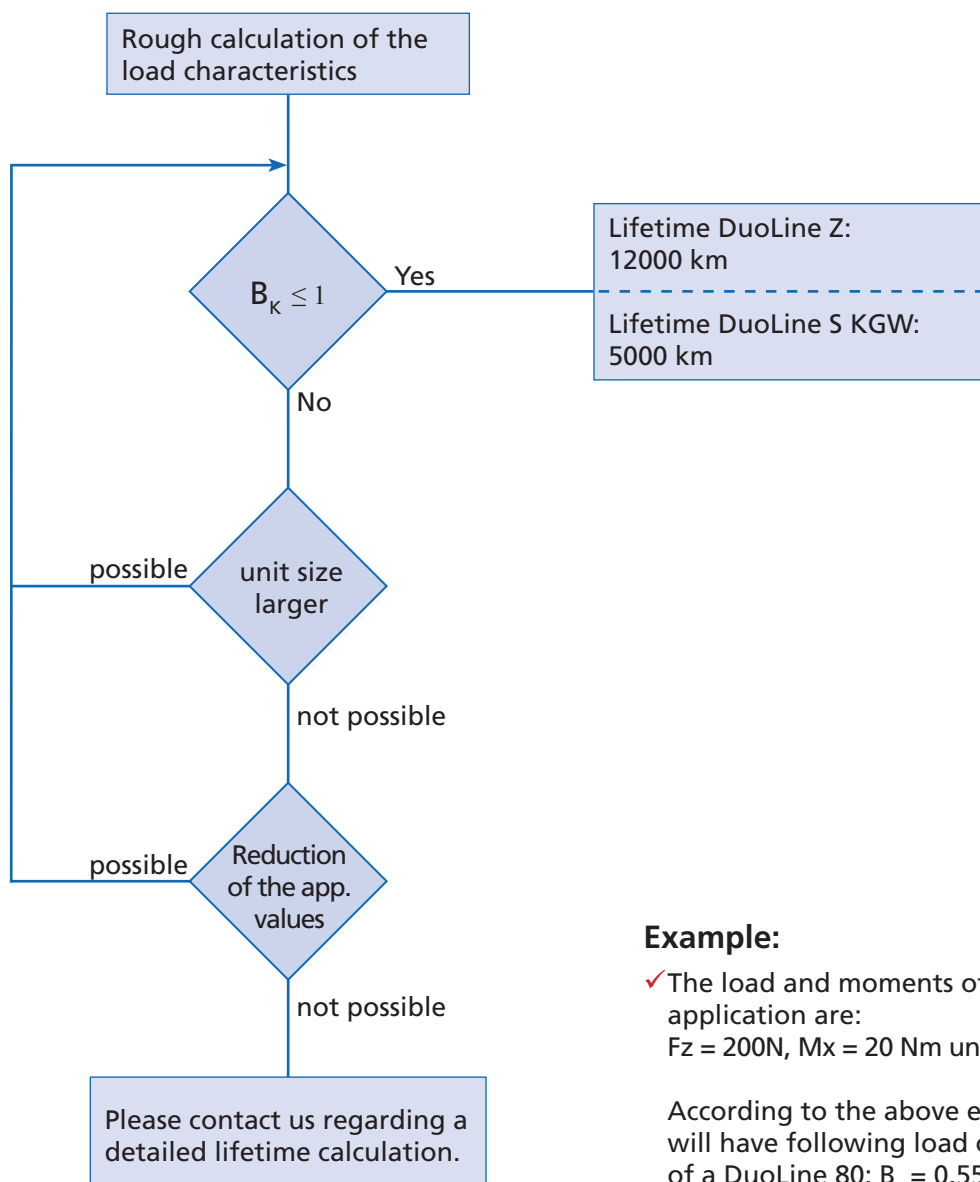

### Example:

- ✓ The load and moments of the application are:  
 $F_z = 200\text{N}$ ,  $M_x = 20\text{ Nm}$  und  $M_z = 45\text{ Nm}$

According to the above equation you will have following load characteristic of a DuoLine 80:  $B_k = 0.55$ .

## General information / operating conditions

	RK DuoLine S 80	RK DuoLine S 80	RK DuoLine S 120	RK DuoLine S 160
Guidance system	1 Ball rail system	1 Ball rail system	2 Ball rail system	1 Ball rail system
Installation position	any position			
Max. driving torque	18 Nm	17 Nm	32 Nm	52 Nm
Max. speed	0.02 / 0.04 m/s (regardless of travel)	0.24 / 0.94 / 2.4 m/s (regardless of travel)	0,24 / 1,2 / 2,4 m/s (regardless of travel)	2 m/s (regardless of travel)
Max. acceleration	3 m/s <sup>2</sup>	20 m/s <sup>2</sup>	20 m/s <sup>2</sup>	20 m/s <sup>2</sup>
Repeat accuracy	± 0,1 mm	± 0,04 mm	± 0,04 mm	± 0,04 mm
Positioning accuracy	-	with integrated position sensing system ± (0.025 + 0.01 x L) mm; L = travel in meters		
Max. no-load torque	1,0 Nm	0,6 Nm	0,7 Nm	0,9 Nm
Drive	Trapezoidal thread , Ø20, Pitch 4 or 8 mm, on the right	Ball-and-screw, Ø 20, Pitch 5, 20 or 50 mm, on the right	Ball-and-screw, Ø25, Pitch 5, 20 or 50 mm	Ball-and-screw, Ø 32, Pitch 40 mm, on the right
Pitch accuracy	(± 0,1 / 300 mm)	T5 (± 0,023 / 300 mm)	T5 (± 0,023 / 300 mm)	T5 (± 0,023 / 300 mm)
Duty cycle	S3 30% Basis 1h	S3 100%	S3 100%	S3 100%
Ambient temperature	0 bis +60°C	0 bis +60°C	0 bis +60°C	0 bis +60°C
Degree of protection	IP 40	IP 40	IP 40	IP 40

## Dynamic load data

Force [N]

Torque [Nm]

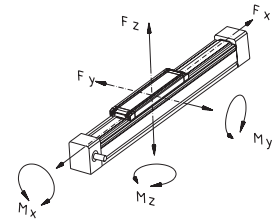

Spindle drive							
Load data	Spindle	Fx	Fy	Fz	Mx	My	Mz
Standard guide carriagew							
RK DuoLine S 80	20x4 / 20x8	2500	1000	4100	100	380	350
	20x5	950					
	20x20	1420					
	20x50	2250					
RK DuoLine S 120	25x5	1240	2000	6900	205	620	560
	25x25	2700					
	25x50	3400					
RK DuoLine S 160	32x40	8000	5100	8900	500	840	810
Extended guide carriage							
RK DuoLine S 80	20x4 / 20x8	2500	1000	4100	100	620	550
	20x5	950					
	20x20	1420					
	20x50	2250					
RK DuoLine S 120	25x5	1240	2000	6900	205	940	790
	25x25	2700					
	25x50	3400					
RK DuoLine S 160	32x40	8000	5100	8900	500	1200	1150

## Geometric moment of inertia

[cm<sup>4</sup>]

	Iy	Iz
RK DuoLine S 80	116,76 cm <sup>4</sup>	165,75 cm <sup>4</sup>
RK DuoLine S 120	290,66 cm <sup>4</sup>	597,45 cm <sup>4</sup>
RK DuoLine 160	437,70 cm <sup>4</sup>	1455,90 cm <sup>4</sup>

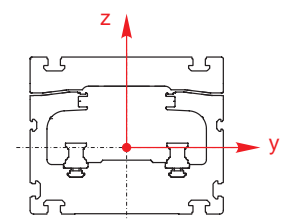

## General information / operating conditions

	RK DuoLine Z 60	RK DuoLine Z 80	RK DuoLine Z 120	RK DuoLine Z 120 II	RK DuoLine Z 160
Guidance system	1 Ball rail system	1 Ball rail system	1 Ball rail system	2 Ball rail system	2 Ball rail system
Installation position	any position				
Max. driving torque	28 Nm	67 Nm	141 Nm	141 Nm	220 Nm
Max. speed	5 m/s	5 m/s	5 m/s	5 m/s	5 m/s
Max. acceleration	50 m/s <sup>2</sup>	50 m/s <sup>2</sup>	50 m/s <sup>2</sup>	50 m/s <sup>2</sup>	50 m/s <sup>2</sup>
Repeat accuracy	± 0,05 mm	± 0,05 mm	± 0,05 mm	± 0,05 mm	± 0,05 mm
Positioning accuracy	with integrated position sensing system ± (0.025 + 0.01 x L) mm; L = travel in meters				
Max. no-load torque	2 Nm	2,2 Nm	2,3 Nm	2,3 Nm	2,5 Nm
Drive	GT Belts from neoprene, Pitch 5 mm, Width 20 mm	GT Belts from neoprene, Pitch 8 mm, Width 30 mm	GT Belts from neoprene, Pitch 8 mm, Width 50 mm	GT Belts from neoprene, Pitch 8 mm, Width 50 mm	GT Belts from neoprene, Pitch 8 mm, Width 75 mm
Active Ø pulley wheel	52,52 mm	66,21 mm	76,39 mm	76,39 mm	76,39 mm
Pulley wheel circumference	165 mm	208 mm	239,99 mm	239,99 mm	239,99 mm
Ambient temperature	0 to +60°C	0 to +60°C	0 to +60°C	0 to +60°C	0 to +60°C
Degree of protection	Basic IP 20 / Protect IP 40	Basic IP 20 / Protect IP 40	Basic IP 20 / Protect IP 40	Basic IP 20 / Protect IP 40	Basic IP 20 / Protect IP 40

## Dynamic load data

Force [N]

Torque [Nm]

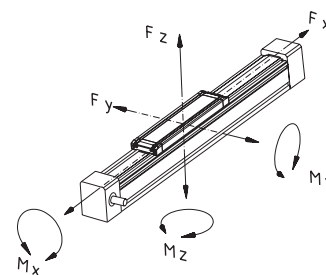

Toothed-belt drive						
Load data	Fx	Fy	Fz	Mx	My	Mz
Standard guide carriagew						
RK Duoline Z 60	900	700	2500	48	160	140
RK Duoline Z 80	2000	1000	4100	100	340	300
RK Duoline Z 120	3600	1400	6400	125	550	530
RK Duoline Z 120 II	3600	2000	6900	205	620	560
RK Duoline Z 160	6000	5100	8900	500	840	810
Extended guide carriage						
RK Duoline Z 60	900	700	2500	48	250	220
RK Duoline Z 80	2000	1000	4100	100	590	520
RK Duoline Z 120	3600	1400	6400	125	890	680
RK Duoline Z 120 II	3600	2000	6900	205	940	790
RK Duoline Z 160	6000	5100	8900	500	1200	1150

## Geometric moment of inertia

[cm<sup>4</sup>]

	Iy	Iz
RK DuoLine Z 60	52,54 cm <sup>4</sup>	67,41 cm <sup>4</sup>
RK DuoLine Z 80	127,90 cm <sup>4</sup>	172,80 cm <sup>4</sup>
RK DuoLine Z 120	285,08 cm <sup>4</sup>	597,45 cm <sup>4</sup>
RK DuoLine Z 120 II	290,66 cm <sup>4</sup>	597,45 cm <sup>4</sup>
RK DuoLine 160	437,70 cm <sup>4</sup>	1455,90 cm <sup>4</sup>

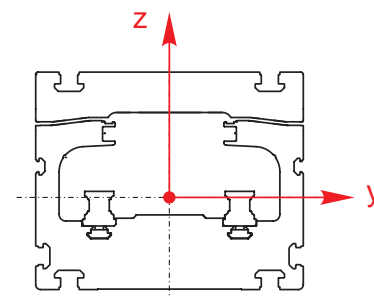



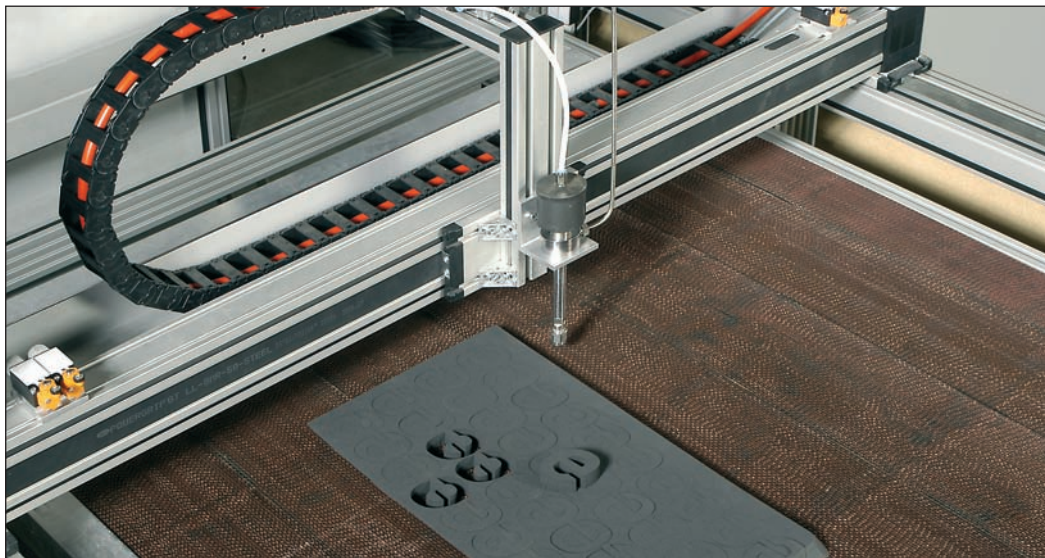
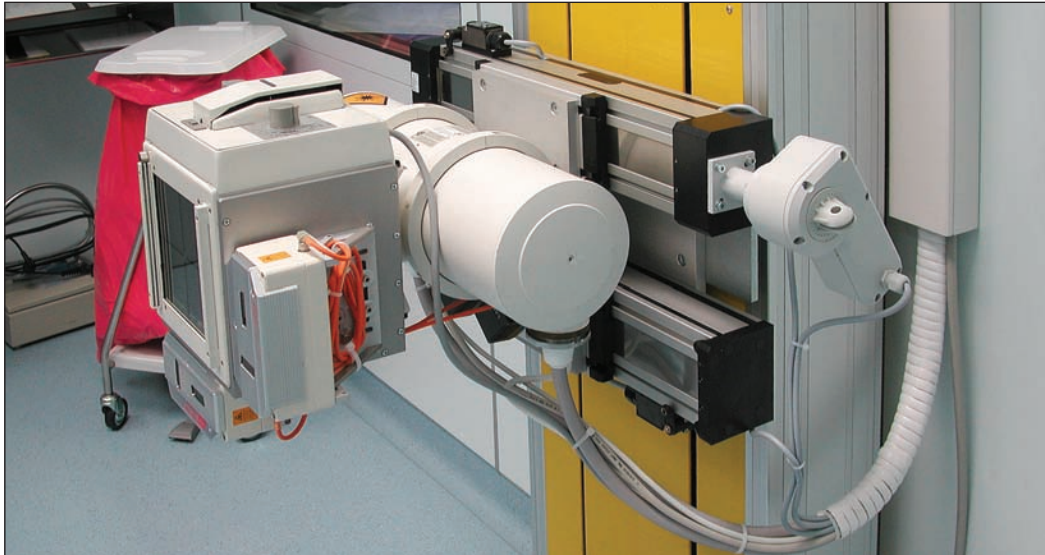

# Dimensions / ordering data

## Order information:

- Second free concurrent carriage on request
- Also available without screw drive as a torque support
- Lubrication over carriages on request

## Spindle unit RK DuoLine S with trapezoidal screw Move-Tec



### Key feature:

- ✓ Lubricated for life up to 30km running performance

	Code No.	Type	Basic length	B	C	D1	D2
NEW	TD13A2A1A1_B0_...	RK DuoLine S 80 Protect	370	80	100	Ø42 <sup>H7</sup> 2.3 deep	Ø14 <sub>K7</sub>
NEW	TD13A2A1B1_B0	RK DuoLine S 80 Protect with extended guide carriage	502	80	100	Ø42 <sup>H7</sup> 2.3 deep	Ø14 <sub>K7</sub>

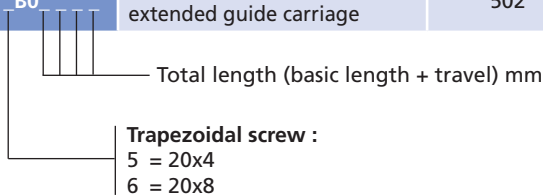

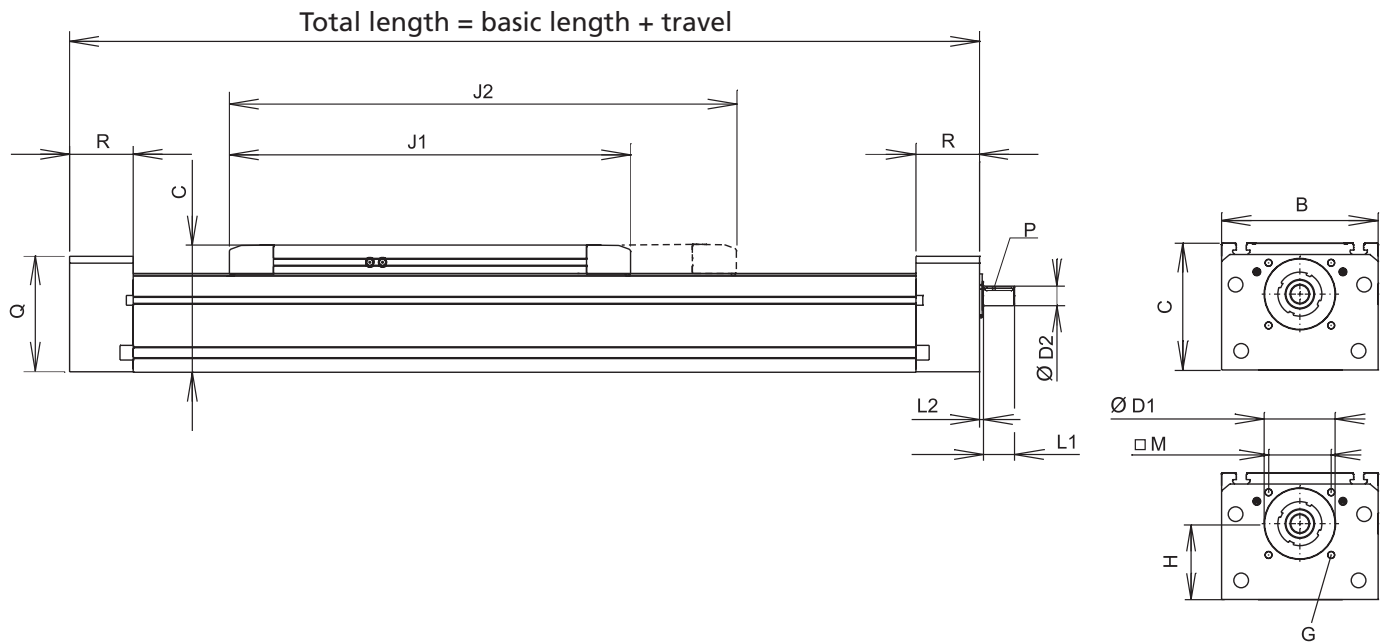

[mm]

G	H	J1	J2	L1	L2	M	P	Q	R	Max. travel	Mass [kg]	
											Basic length	per 100 mm travel
M6-18 deep	57.5	278	-	30	3.8	□46±0.2	5x5x25	89	46	2890	6.74	0.96
M6-18 deep	57.5	-	410	30	3.8	□46±0.2	5x5x25	89	46	2758	8.01	0.96

# Dimensions / ordering data

## Order information:

- Lubrication over carriages on request
- Extended carriages on request

## Spindle unit RK DuoLine S with trapezoidal screw Move-Tec

### Version

- Right and lefthand thread 20x4



### Key feature:

- ✓ Lubricated for life up to 30km running performance

Code No.	Type	Basic length	B	C	D1	D2
NEW TD13A2_1A15B0	RK DuoLine S 80 Protect	648	80	100	Ø42 <sup>H7</sup> 2.3 deep	Ø14 <sub>k7</sub>

NEW

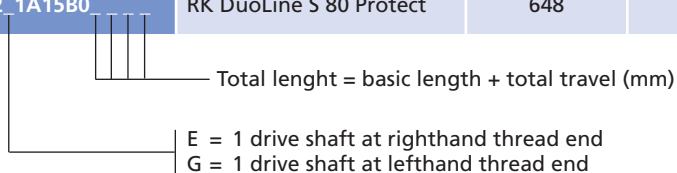

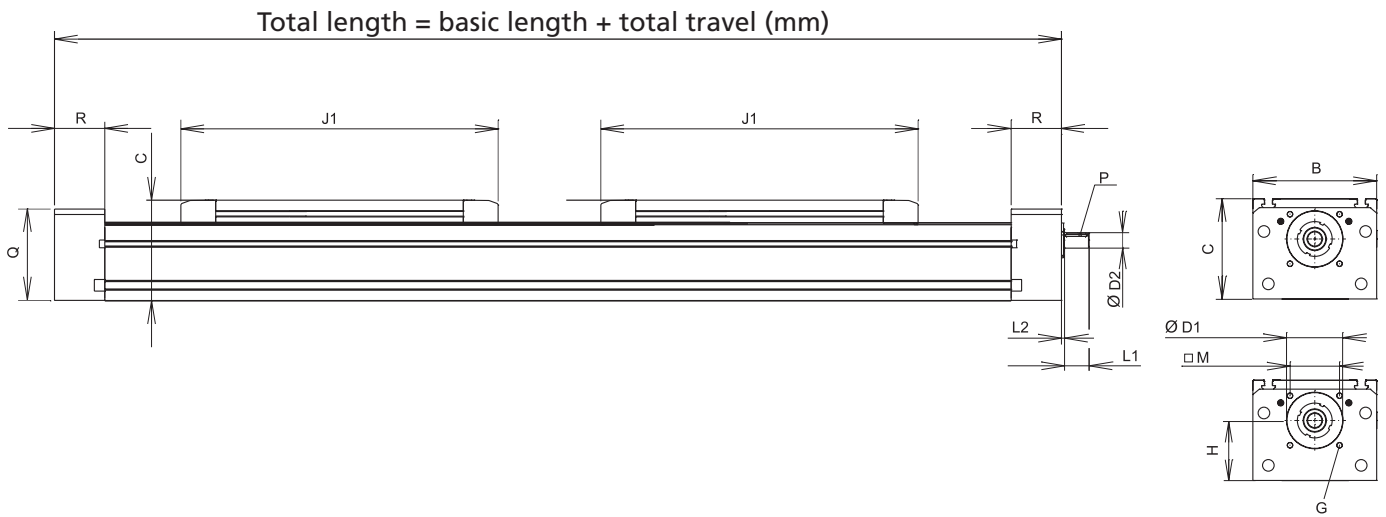

[mm]

G	H	J1	L1	L2	M	P	Q	R	Max. travel	Mass [kg]	
										Basic length	per 100 mm travel
M6-18 deep	57.5	278	30	3.8	□46±0.2	5x5x25	89	46	2890	11.7	0.96

# RK DuoLine R 60/80/120 – Versions

## Order information:

- Longer travel lengths on request
- Integrated position sensing system as Option

## Version

## ■ Guide

Ideal as additional / secondary support for the DuoLine with toothed belt or spindle.



Code No.	Type	Basic length	B	C
TD14A5T1A11A0 _ _ _ _	RK DuoLine R 60	289	60	80
TD14A5T1B11A0 _ _ _ _	RK DuoLine R 60 with extended guide carriage	379		
TD14A2T1A11A0 _ _ _ _	RK DuoLine R 80	352	80	100
TD14A2T1B11A0 _ _ _ _	RK DuoLine R 80 with extended guide carriage	484		
TD14A3T1A11A _ _ _ _	RK DuoLine R 120 one ball rail guide	472	120	115
TD14A3T1B11A _ _ _ _	RK DuoLine R 120 one ball rail guide with extended guide carriage	616		

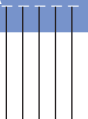

Total length = basic length + total travel (mm)

For Place-Tec and Control-Tec

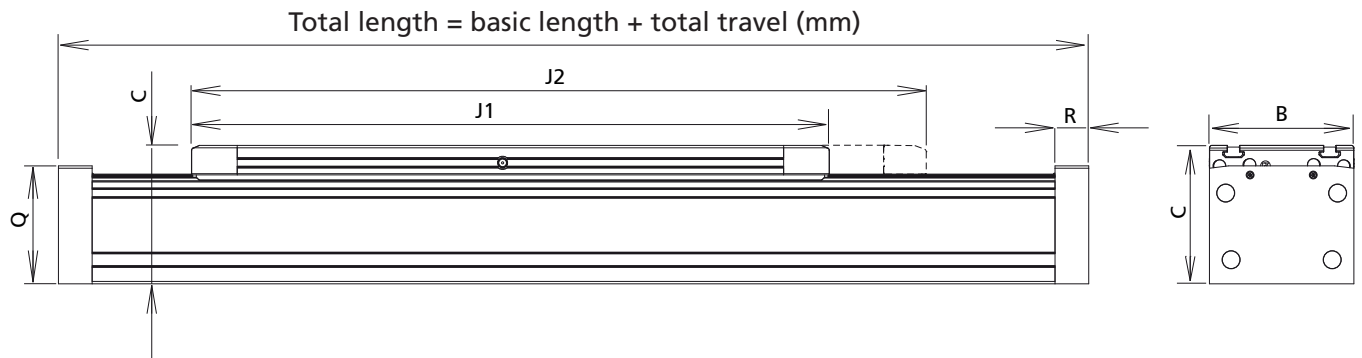

[mm]

J1	J2	Q	R	max. travel	Mass [kg]	
					Basic length	per 100 mm travel
245	–	70	22	3587	3,73	0,54
–	335			3497	4,46	0,54
278	–	97	22	7692	5,22	0,83
–	410			7560	6,89	0,83
386	–	98	28	7584	9,76	1,19
–	530			7440	12,16	1,19

# Dimensions / ordering data

## Order information:

- Longer travel lengths on request
- Also available without screw drive as a torque support

## Timing-belt unit RK DuoLine Z Place-Tec



Code No.	Type	Basic length	B	C	D1	D2
TD1_A5F1A11A_ _ _ _ _	RK DuoLine Z 60	405	60	80	62 <sup>H7</sup> 5 deep	15 <sup>H6</sup>
TD1_A5F1B11A_ _ _ _ _	RK DuoLine Z 60 one ball rail guide with extended guide carriage	495				
TD1_A2F1A_1A_ _ _ _ _	RK DuoLine Z 80	468	80	100	75 <sup>H7</sup> 7 deep	16 <sup>H6</sup>
TD1_A2F1B_1A_ _ _ _ _	RK DuoLine Z 80 with extended guide carriage	600				
TD1_A3F1A_1A_ _ _ _ _	RK DuoLine Z 120 one ball rail guide	606	120	115	90 <sup>H7</sup> 9 deep	20 <sup>H6</sup>
TD1_A3F1B_1A_ _ _ _ _	RK DuoLine Z 120 one ball rail guide with extended guide carriage	750				
TD1_A4F1A_1A_ _ _ _ _	RK DuoLine Z 120 two ball rail guides	606				
TD1_A4F1B_1A_ _ _ _ _	RK DuoLine Z 120 two ball rail guides with extended guide carriage	750				
TD1_A1F1A_1A_ _ _ _ _	RK DuoLine Z 160	630	160	130	90 <sup>H7</sup> 12 deep	25 <sup>H6</sup>
TD1_A1F1B_1A_ _ _ _ _	RK DuoLine Z 160 with extended guide carriage	780				

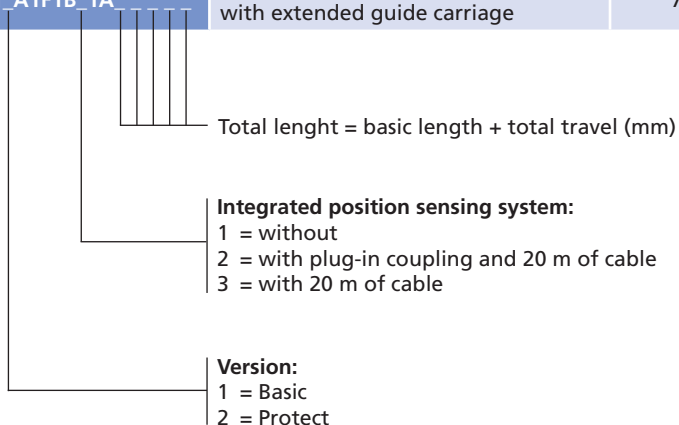



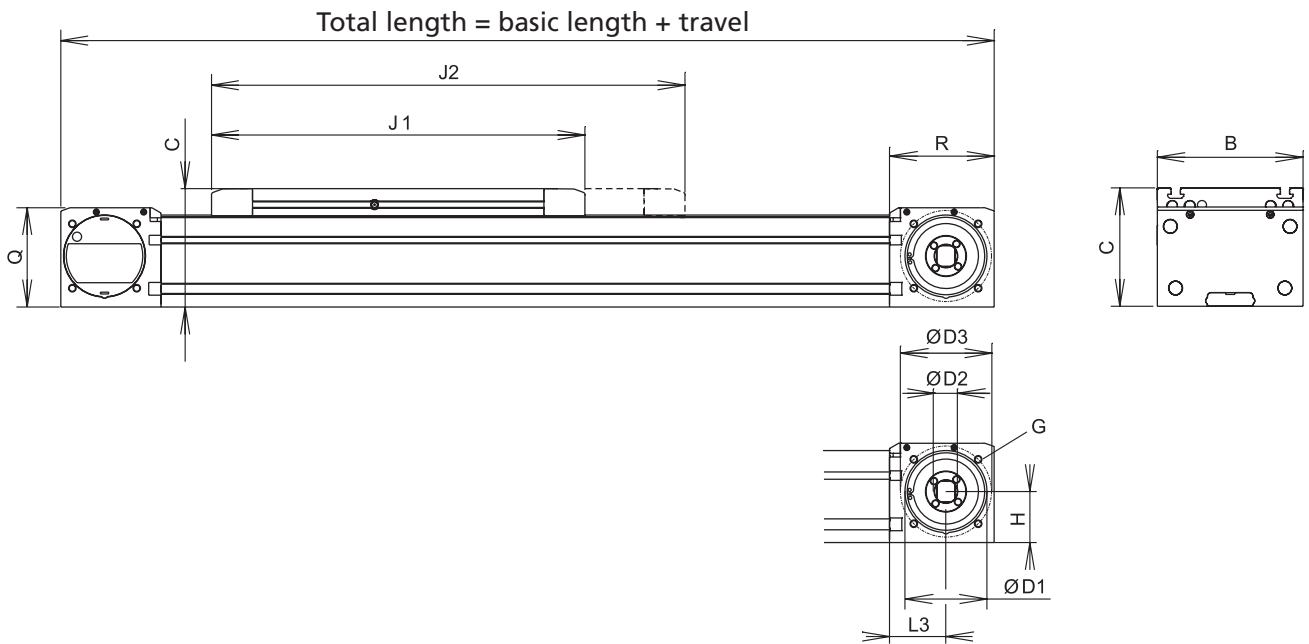

[mm]

D3	G	H	J1	J2	L3	Q	R	max. travel	Mass [kg]		
									Basic length	per 100 mm travel	
72,1±0.2	M6-12 deep	33.8	245	–	44	70	80	5753	4.65	0.54	
			–	335					5.38	0.54	
90.5±0.2	M8-12 deep	40.1	278	–	52	85	95	7722	7.84	0.83	
			–	410					9.51	0.83	
100±0.2	M8-16 deep	46.8	386	–	62	98	110	7614	16.33	1.19	
			–	530					18.72	1.19	
			386	–					5614	16.33	1.19
			–	530					5470	18.72	1.19
100±0.2	M8-28 deep	56	410	–	62	109	110	9010	25.76	1.80	
			–	560					8860	28.16	1.80

# Dimensions / ordering data

## Order information:

- Second free concurrent carriage on request
- Also available without screw drive as a torque support

## Spindle unit RK DuoLine S with ball screw Control-Tec



Code No.	Type	Basic length			B	C	D1	D2
		Total length of up to 1171 mm	Total length of 1172-3051 mm	Total length of 3052 mm				
TD13A2A1A__A0__	RK DuoLine S 80 Protect	370	415	495	80	100	Ø42 <sup>H7</sup> 2,3 deep	Ø14 <sub>K7</sub>
TD13A2A1B__A0__	RK DuoLine S 80 Protect with extended guide carriage	502	547	627	80	100	Ø42 <sup>H7</sup> 2,3 deep	Ø14 <sub>K7</sub>

Total length = basic length + total travel (mm)

**Ball screw:**  
 3 = 20x5  
 1 = 20x20  
 2 = 20x50

**Integrated position sensing system:**  
 1 = without  
 2 = with plug-in coupling and 20 m of cable  
 3 = with 20 m of cable

Code No.	Type	Basic length		B	C	D1	D2
		Total length of up to 3042 mm	Total length of 3043 mm				
TD13A4A1A1__A0__	RK DuoLine S 120 Protect	498	614	120	115	Ø55 <sup>H7</sup> 2,3 deep	Ø16 <sub>K6</sub>
TD13A4A1B__A0__	RK DuoLine S 120 Protect with extended guide carriage	642	758				

Total length = basic length + total travel (mm)

**Ball screw:**  
 1 = 25x5  
 2 = 25x25  
 3 = 25x50

**Integrated position sensing system:**  
 1 = without  
 2 = with plug-in coupling and 20 m of cable  
 3 = with 20 m of cable

Code No.	Type	Basic length			B	C	D1	D2
		Total length of up to 1350 mm	Total length of 1351-3350 mm	Total length of 3351 mm				
TD13A1A1A12A0__	RK DuoLine S 160 Protect	540	602	702	160	130	Ø75 <sup>H7</sup> 2,3 deep	Ø20 <sub>K8</sub>
TD13A1A1B__2A0__	RK DuoLine S 160 Protect with extended guide carriage	690	752	852	160	130	Ø75 <sup>H7</sup> 2,3 deep	Ø20 <sub>K8</sub>

Total length = basic length + total travel (mm)

**Integrated position sensing system:**  
 1 = without  
 2 = with plug-in coupling and 20 m of cable  
 3 = with 20 m of cable

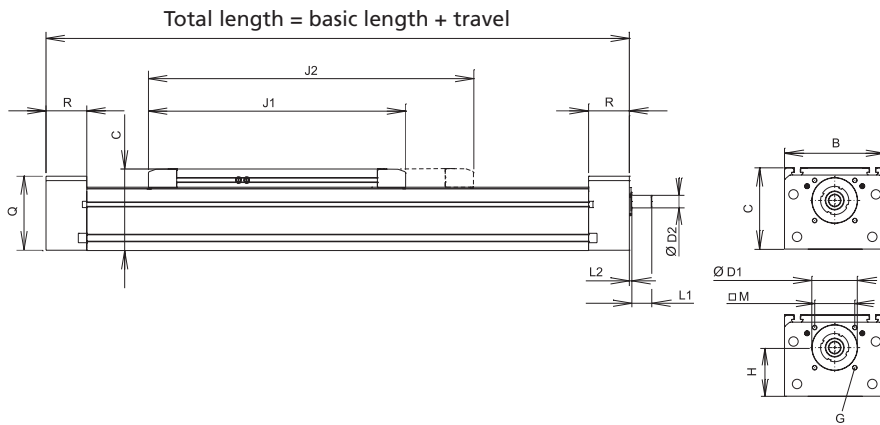

[mm]

G	H	J1	J2	L1	L2	M	Q	R	max. travel	Mass [kg]	
										Basic length	per 100 mm travel
M6-18 deep	57,5	278	-	30	3,8	□46±0,2	89	46	4440	6,74	0,96
M6-18 deep	57,5	-	410	30	3,8	□46±0,2	89	46	4368	8,01	0,96

[mm]

G	H	J1	J2	L1	L2	M	Q	R	max. travel	Mass [kg]	
										Basic length	per 100 mm travel
M6-18 deep	72,7	386	-	30	2,5	□40±0,2	104	55	4591	14,57	1,49
		-	530							16,74	1,49

[mm]

G	H	J1	J2	L1	L2	M	Q	R	max. travel	Mass [kg]	
										Basic length	per 100 mm travel
M8-22 deep	78	410	-	32	3,7	□64±0,2	118	65	4300	23,26	2,21
M8-22 deep	78	-	560	32	3,7	□64±0,2	118	65	4150	26,59	2,21

# Fixation

## Fixation of payload

- Two slot stone strips have been inserted in the guide carriage on which fittings can be securely attached in a variety of ways
- Profile slots in the guide carriage and guide profiles facilitate fixation

### RK DuoLine R/S/Z 60

\*only with version with extended guide carriage

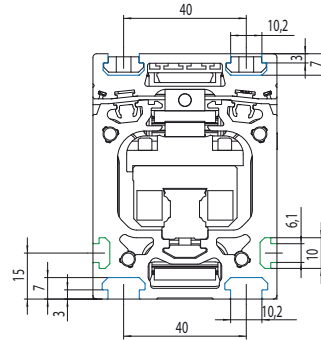
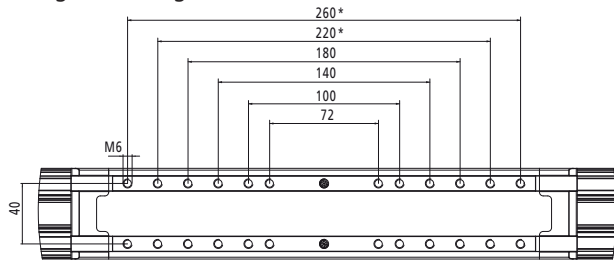

- 20 slot geometry
- 30 slot geometry

### RK DuoLine R/S/Z 80

\*only with version with extended guide carriage

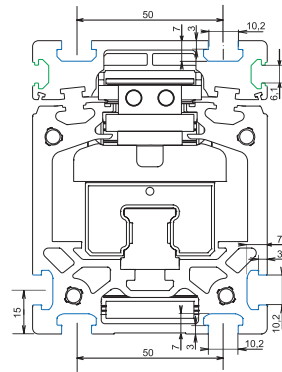
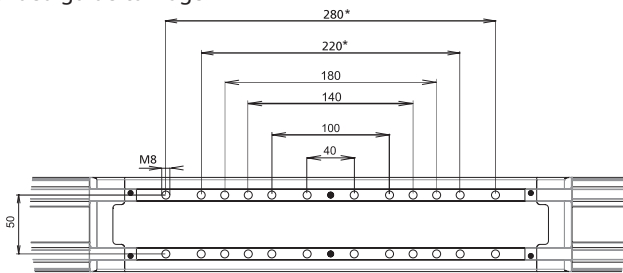

- 20 slot geometry
- 30 slot geometry

### RK DuoLine R/S/Z 120

\*only with version with extended guide carriage

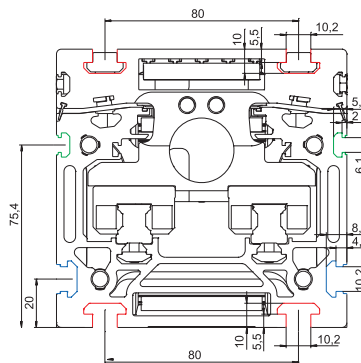
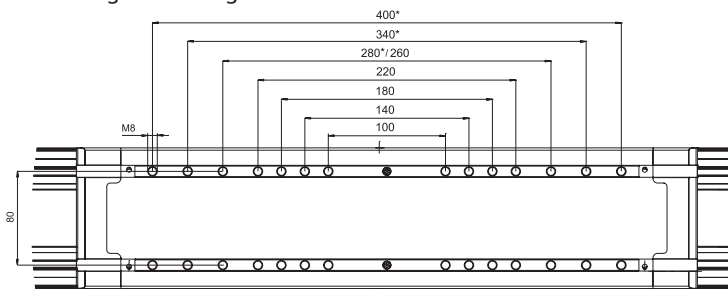

- 20 slot geometry
- 30 slot geometry
- 40 slot geometry

### RK DuoLine S/Z 160

\*only with version with extended guide carriage

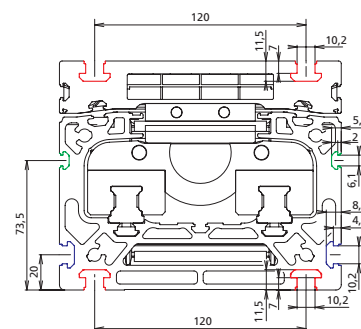
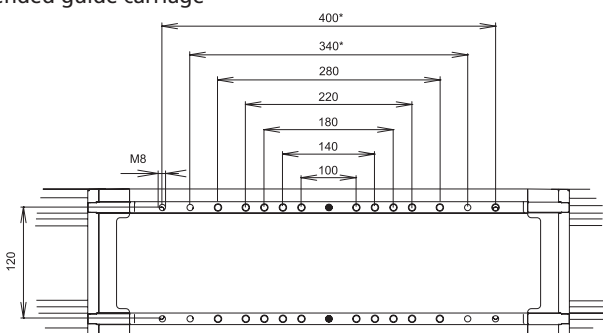

- 20 slot geometry
- 30 slot geometry
- 40 slot geometry

## Clamping strips

- Clamping strips facilitate fixation of the linear unit to the chassis or two units to a crossing table

**Material:** Natural anodised aluminium, galvanised fixation material.  
**Scope of delivery:** 2 clamping strips with fixation material

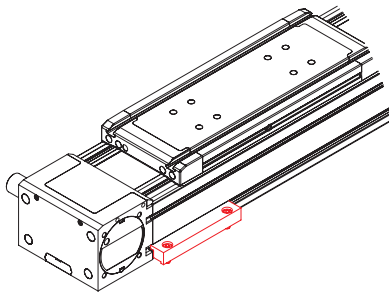

Fig. 1: Ground assembly

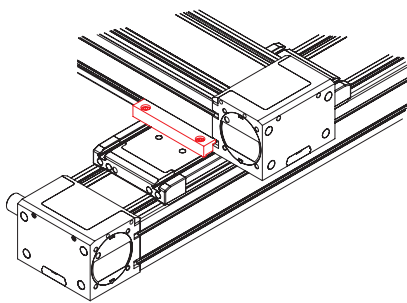
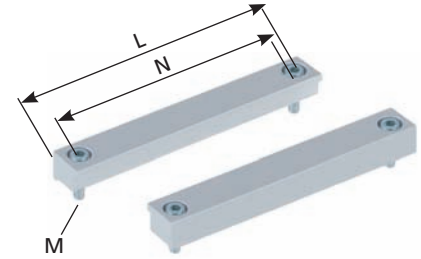
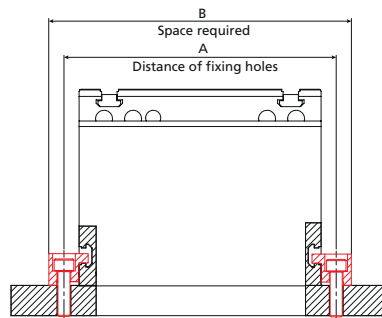

Fig. 2: Crossing units

Code No.	Type	Abb.	A	B	L	M	N
91818	RK DuoLine 60 ground assembly	1	84	91	57	M6	40
	RK DuoLine 60 crossing to 60	2					
91806	RK DuoLine 80 ground assembly	1	100	122	76	M8	50
	RK DuoLine 80 crossing to 80	2					
91812	RK DuoLine 120 ground assembly	1	140	160	116	M8	80
	RK DuoLine 120 crossing to 120	2					
	RK DuoLine 160 crossing to 120	2					
91802	RK DuoLine 160 ground assembly	1	180	200	156	M8	120
	RK DuoLine 160 crossing to 160	2					
	RK DuoLine 120 crossing to 160	2					

[mm]

## Slot stones

- Slot stones can be inserted and positioned at the guide profile and guide carriage

**Material:** galvanised steel

**Slot stone -B-** can be swivelled into the slot

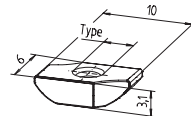

**Slot stone -N-** can be slid into the slot

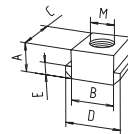

**Slot stone -K-** can be swivelled into the slot

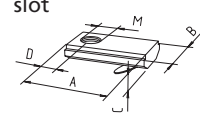

[mm]

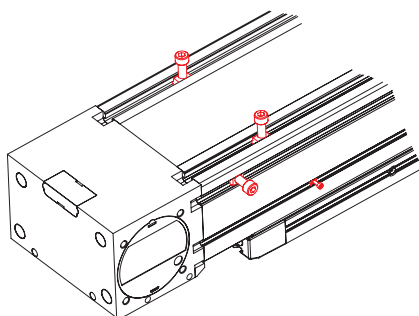

View of DuoLine from below

Code No.	Type	Slot geometry	A	B	C	D	E	M	F [N]
<b>Slot stone -B-</b>									
E0017CEH	M3	20							Pack of 10 units
E0058CEH	M4	20							Pack of 10 units
<b>Slot stone -N-</b>									
4006202	M8	30	5	10	13	13	3	M8	4000
4026206	M8	40	8	10	13	15	4	M8	9000
<b>Slot stone -K-</b>									
4006211	M5	30	21	12	4	7	-	M5	5000
4006212	M6	30	21	12	4	7	-	M6	5000
4016212	M6	40	21	14	4	7	-	M6	5000

## Motor adapter kit for RK AC servomotors

- Complete motor adapter kits manufactured to your specifications on request

**Scope of delivery:**  
Motor adapter kit, elastomer coupling and fixation material

- Servomotors from the RK standard range can be easily connected

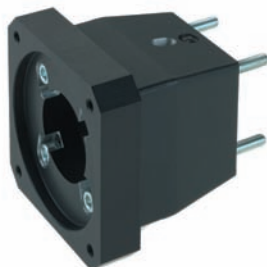

- Motor adapter kits for every motor or gear unit manufacturer

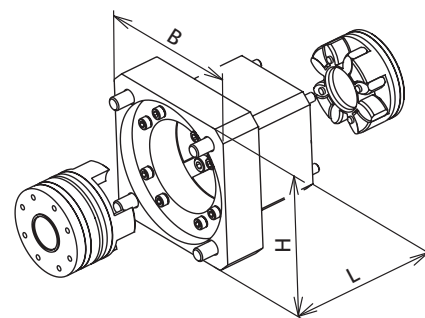

Type	Servo motors without gearbox			
	RK-AC 240	RK-AC 470	RK-AC 800	RK-AC 1252 RK-AC 1776 RK-AC 2521
DuoLine Z 60	949376	–	–	–
DuoLine Z 80	–	949357	–	–
DuoLine S 80 trapezoidal thread	949367	949366	–	–
DuoLine S 80 ball screw	949367	949366	–	–
DuoLine S 120	949123	949124	949125	–
DuoLine S 160	–	–	949340	949342

Type	Servo motors with gearbox					Three phase motors	
	RK-AC 112	RK-AC 260	RK-AC 345	RK-AC 800	RK-AC 1252 RK-AC 1776 RK-AC 2521	90/120 W	180/250 W
DuoLine Z 60	949374	949375	–	–	–	949377	949378
DuoLine Z 80	949350	949353	949354	–	–	949355	949356
DuoLine Z 120	–	949371	949370	949370	–	949372	949373
DuoLine Z 160	–	–	949344	949344	949355	–	–
DuoLine S 80 trapezoidal thread	949360	949364	–	–	–	949368	949369
DuoLine S 80 ball screw	949360	949364	–	–	–	949363	949365
DuoLine S 120	949121	949122	–	–	–	949126	949127
DuoLine S 160	–	–	949341	949341	949343	–	–

## Drive shaft

- The RK DuoLine Z is fitted as standard with a hollow shaft
- This can be retrofitted with a drive shaft as an optional extra

**Scope of delivery:**  
Drive shaft with fixation material

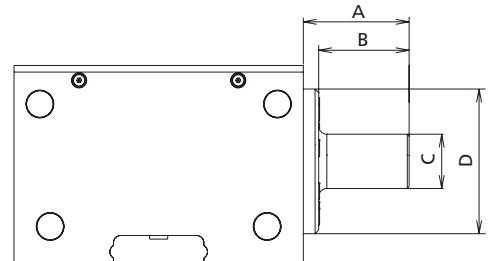

For metal bellows coupling

[mm]

Code No.	Type	Version	A	B	C	D
91328	RK DuoLine Z 60	Drive shaft for metal bellows coupling	28.6	25	16	44
91312	RK DuoLine Z 80		35	31.5	20	52
91320	RK DuoLine Z 120		45.5	39	25	74
9720000	RK DuoLine Z 160		58.5	50	30	80

# Drive / Position determination

## Synchronising shaft

- For torque transmission with parallel linear units
- Synchronisation of the guide carriages by zero point alignment

**Scope of delivery:**  
Synchronising shaft with fixation material

### Max. transfer torque:

RK DuoLine Z 60	28 Nm
RK DuoLine Z 80	67 Nm
RK DuoLine Z 120	141 Nm
RK DuoLine Z 160	220 Nm

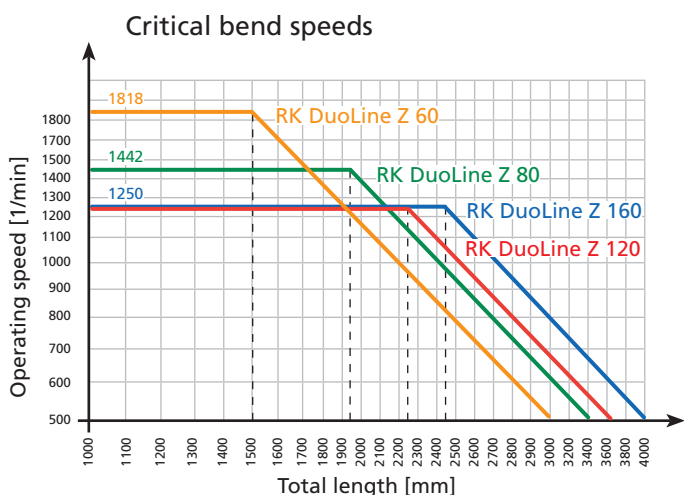
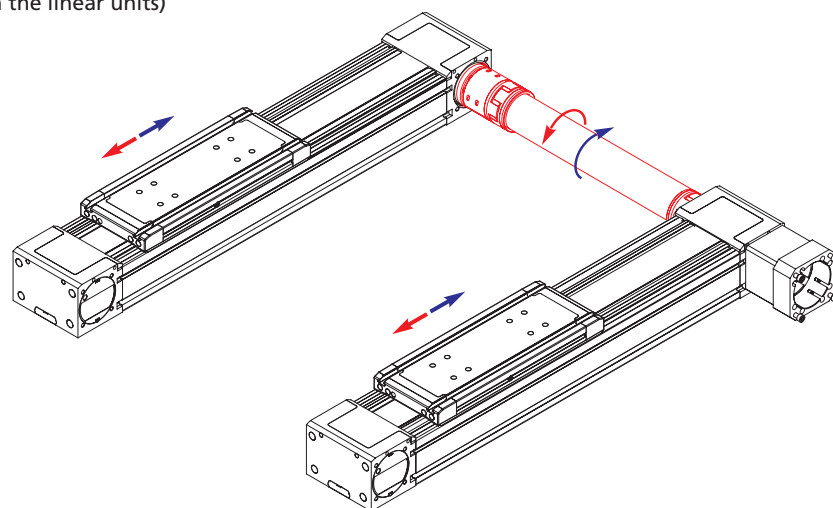
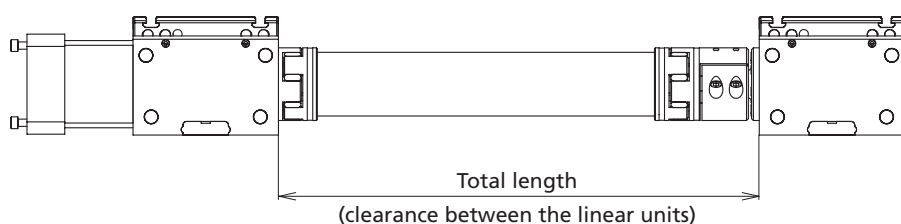

[mm]

Code No.	Type	Basic length (minimum length)	Max. length	Weight [kg]	
				Basic length	per 100 mm travel
92548_ _ _ _	Synchronising shaft RK DuoLine Z 60	118	2985	0,53	0,09
92538_ _ _ _	Synchronising shaft RK DuoLine Z 80	144	3400	1,07	0,12
92519_ _ _ _	Synchronising shaft RK DuoLine Z 120	175	3994	1,38	0,15
92510_ _ _ _	Synchronising shaft RK DuoLine Z 160	220	3991	3,42	0,22

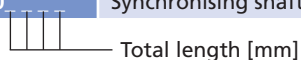



## Mechanical limit switch

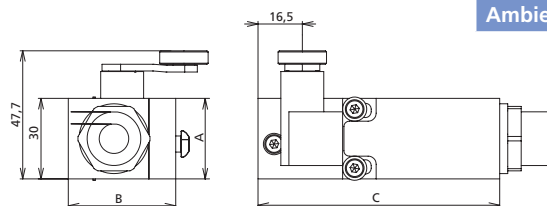
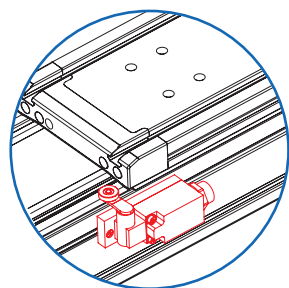

- External fixation on the guide profile

**Scope of delivery:**  
Limit switch with set of fixing items

Voltage	max. 230 V AC
Max. switching current	4 A
Max. starting current	10 A
Operating frequency	max. 5000 / h
Mechanical lifetime	20x10 <sup>6</sup> cycles
Axis leverage adjustment	locking by 360°
Degree of protection	IP67
Ambient temperature	-30°C to +80°C

Code No.	Type	A	B	C	Version
92848	RK DuoLine 60	49	39	82	NO / NC, mechanical limit switch
91919	RK DuoLine 80	63	40	83	
92701	RK DuoLine 120	31	40	97	
91910	RK DuoLine 160	30	40	90	

## External inductive limit switch

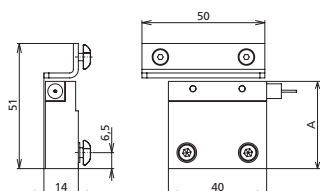
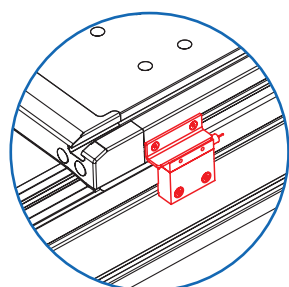

- External fixation on the guide profile

**Scope of delivery:**  
Limit switch with set of fixing items

Limit switch	external	internal
Voltage	10...30 VDC	10...30 VDC
Max. switching current	100 mA	100 mA
Operating frequency	max. 5 kHz	max. 5 kHz
Mechanical lifetime	independent of operating cycles	independent of operating cycles
Operating distance	2 mm	1.5 mm
Degree of protection	IP65	IP67
Cable length	2.5 m	5 m
Ambient temperature	-25°C to +70°C	-25°C to +70°C

Code No.	Type	A	Version
92838	RK DuoLine 60	52,8	NO, External inductive limit switch
92819	RK DuoLine 80	71,5	
92840	RK DuoLine 120	22	
92810	RK DuoLine 160	35,5	

## Internal inductive limit switch

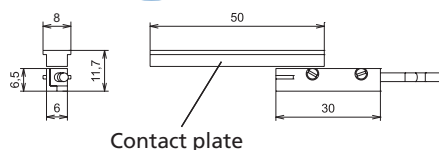
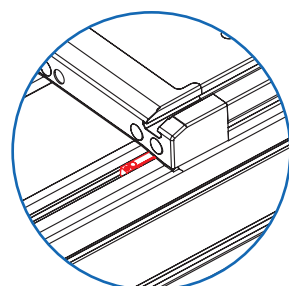

- Proximity switch integrated in the guide profile – no protruding contours

**Scope of delivery:**  
Proximity switch with set of fixing items

Code No.	Type	Version
92828	RK DuoLine 60	NO, Internal inductive limit switch
92820*	RK DuoLine 80	
	RK DuoLine 120 RK DuoLine 160	

\*On this limit switch, the slot must be sealed off with a cover profile

## Cover profile

Code No.	Version		
E00024DAC	bar	black	2.000 mm

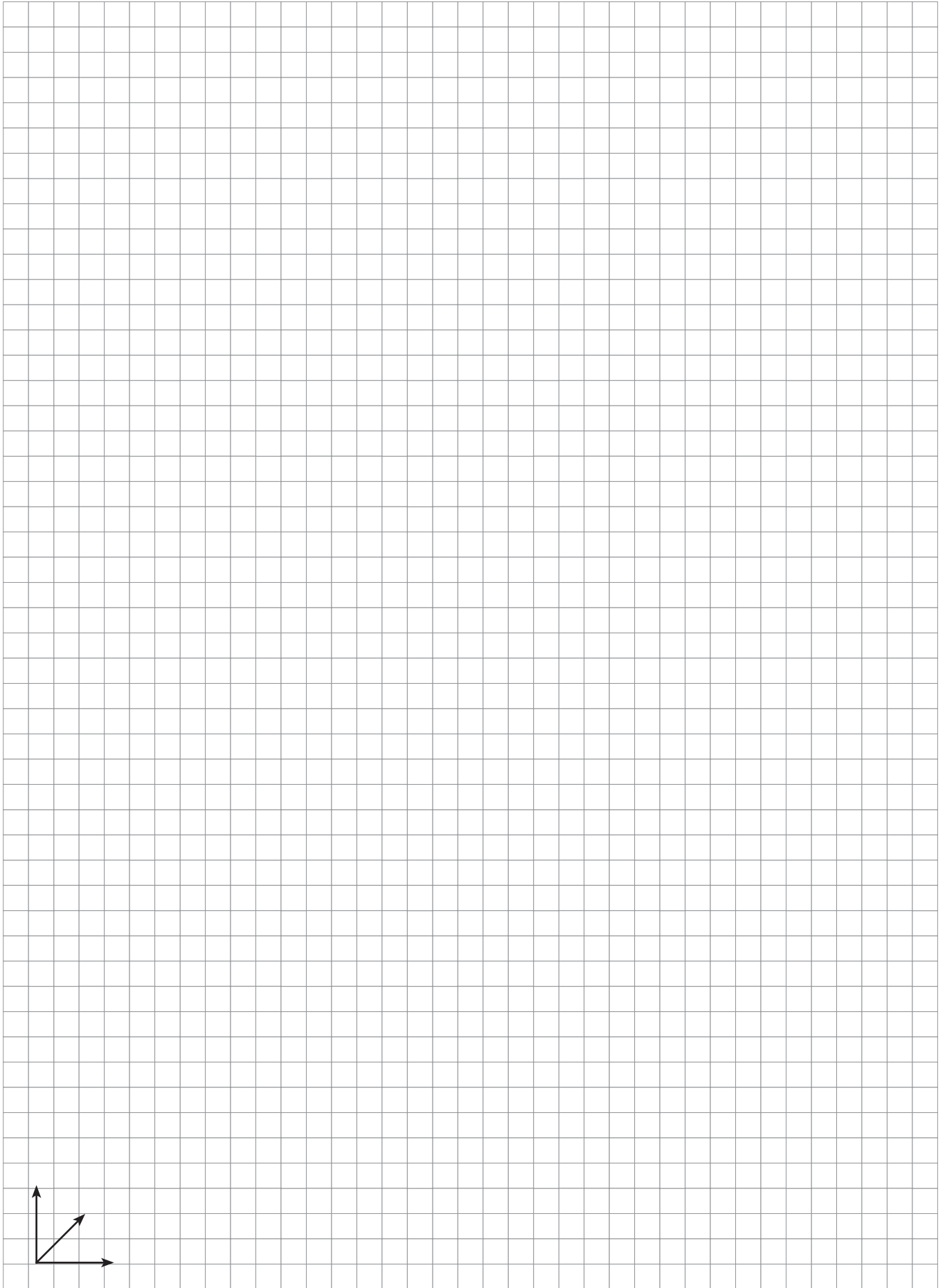

## What we can do for you

Do you need to focus your resources on other tasks and are you looking for a competent partner you can rely on? Working in close collaboration with you, our specialists will develop solutions tailor-made to meet your needs. If you wish, we can also assemble and commission the units on site.

- Just make a sketch of your requirements

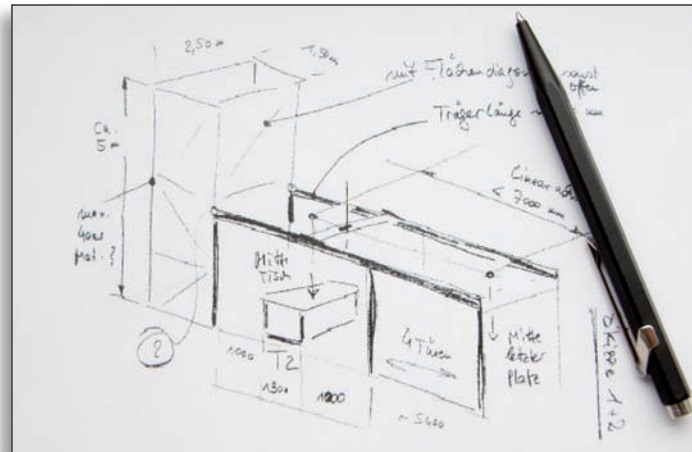

- Our product specialists will devise a solution for you



- We can deliver your turnkey solution or assemble and commission it for you on site

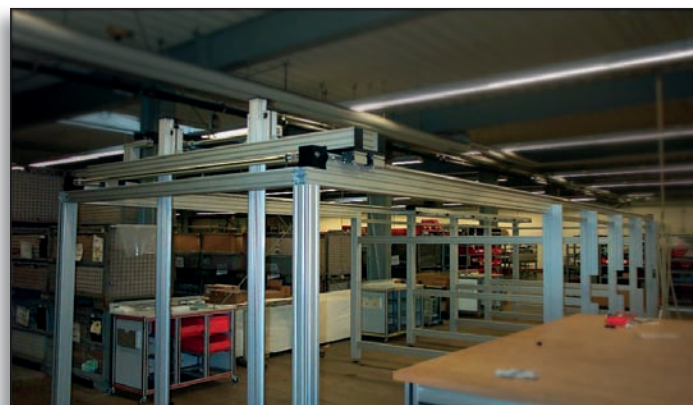

**R** RENOWNED  
KNOW-HOW

  
**RK ROSE+KRIEGER**

A Phoenix Mecano Company

**LINEAR-  
PROFILE-  
CONNECTING-  
MODULE-  
TECHNOLOGY**



## FAX reply form

Yes, I would like to know more about  
RK linear technology, please:

send me the linear technology catalogue

send me details of your product range in PDF  
format on a CD-ROM Contact me

contact me

Company: \_\_\_\_\_

Contact partner: \_\_\_\_\_

Department: \_\_\_\_\_

Address: \_\_\_\_\_

Tel. + Fax: \_\_\_\_\_

E-mail: \_\_\_\_\_

  
**RK ROSE+KRIEGER**  
Connecting and positioning systems

RK Rose+Krieger GmbH  
Postfach 15 64  
32375 Minden, Germany  
Telephone: +49 (0)571 93 35-0  
Fax: +49 (0)571 93 35-119  
E-mail: info@rk-online.de  
Internet: www.rk-rose-krieger.com