

## ELASTOMERIC™ Couplings

A Proven  
and Unique Concept  
in a Non-Lubricated  
Flexible Coupling

Standard Hubs are  
Available From Stock,  
in Aluminum, Steel  
and Stainless Steel.

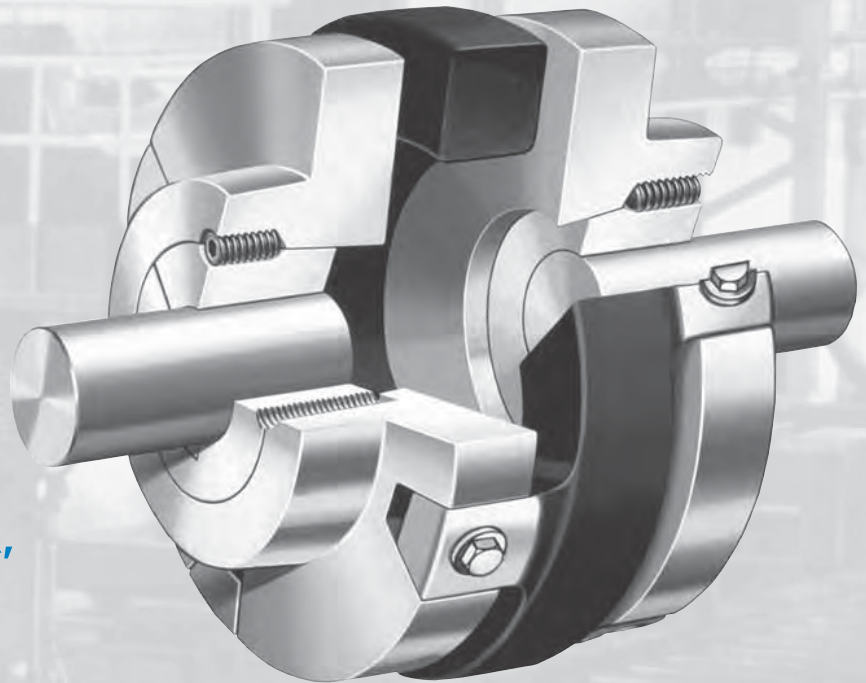

### Index:

	Page
<b>HOW TO ORDER</b> .....	73
Technical Advantages.....	70 - 71
Service Factors.....	72
Selection Procedure .....	73
Standard Coupling Type EE	
Finished Straight Bores.....	74
TAPER-LOCK* Bushings .....	75
Q-D® Bushings .....	75
Drop-Out Spacer Coupling Type DO .....	76 - 77
Double Spacer Coupling Type SS .....	78
Single Spacer Coupling Type ES.....	78
Spacer Coupling for TAPER-LOCK* Bushing .....	79
Spacer Coupling for Q-D® Bushing.....	80
Mill Motor Coupling Type EM.....	81
Coupling Comments .....	82

Visit [www.emerson-ept.com](http://www.emerson-ept.com)

\* Taper-Lock is believed to be the trademark and/or trade name of Reliance Electric Company, and is not owned or controlled by Emerson Power Transmission.

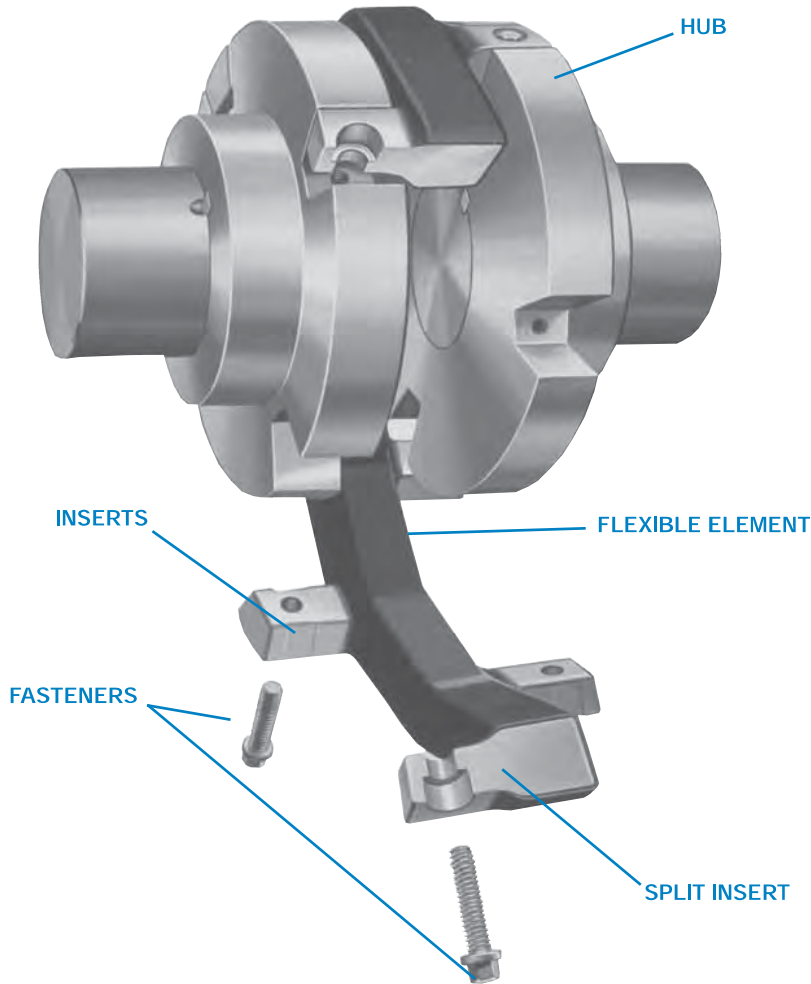

**LONG LIFE** The ELASTOMERIC™ Coupling provides long service life — for the coupling, the bearings and the seals. The design concept contributes to **better** low-cost power transmission with the added benefits of absorbing shock loads and smoothing-out damaging vibrations.

**SIMPLE INSTALLATION** Just mount the hubs, align the shafts and install the flexible element — in a few short minutes. Assembly is completely visible — with no hidden or hard to reach components. The flexible element can be replaced without disturbing foundation bolts or shaft alignment.

**WRAP-AROUND DESIGN** The split insert permits **easy installation** of the flexible element in a simple assembly sequence — with no blind assembly required and shafts may be aligned prior to its installation. With the “split” in the insert and not in the rubber, the joint in the ELASTOMERIC™ Coupling is firmly contained, eliminating distortions and unbalance due to centrifugal force.

**RUBBER IN COMPRESSION** This is the most **efficient** way to transfer torque through an elastomeric element; much more efficient than rubber in shear! Rubber in compression, as used in the ELASTOMERIC™ coupling, can be loaded from 5 to 10 times as high as rubber in tension or shear. And the rubber-to-metal bond is permanent — with a compressive load maintained at all times.

**PLUS PRECOMPRESSION** It is **precompression** which assures that the unloaded segments of the flexible element remain in compression, protecting both the rubber itself and the rubber-to-metal bond. Application of torque in the ELASTOMERIC™ Coupling increases the compressive stress on the loaded legs while the alternate legs experience a reduction in compressive stress — but not to the point of complete relaxation.

**DYNAMICALLY STABLE** Distortion of the element due to centrifugal force is contained by the inserts imbedded and bonded in the element and fastened to the hub flanges. Torsional wind-up effects are avoided by driving through compression. These factors greatly reduce axial movement which can lead to damaged bearings, seals, and shaft-mounted equipment such as gears or armatures.

**CUSHIONS SHOCK LOADS** Resilience in the flexible element cushions the shock of impact loading, providing smooth and quiet power transmission. This protects both the driving and driven equipment, providing longer machine life.

**DAMPENS TORSIONAL VIBRATIONS** The flexible element absorbs the unavoidable torsional vibrations typically found in internal combustion engines and other reciprocating equipment. The ELASTOMERIC™ Coupling is available for both flywheel mounting and for assembly on stub shafts.

**CORROSION RESISTANT** The use of corrosion resistant, non-staining aluminum alloys and cadmium plated steel capscrews eliminate the problems normally associated with coupling usage in normal industrial atmospheres — corroded bores and fasteners, contamination from flaking and poor appearance.

**SHAFT MISALIGNMENT** The flexing characteristics of the elastomeric member permit generous shaft misalignments — parallel, angular and axial — under continuous operating conditions.

It is this misalignment capability that compensates for foundation settling, thermal growth, bearing wear, mechanical strains and even installation alignment error.

Since maximum coupling life will be obtained with minimum shaft misalignment, it is recommended that shafts be carefully and accurately aligned at time of installation.

### A Proven and Unique Concept in a Non-Lubricated Flexible Coupling

**ALLOYED ALUMINUM** High-strength aluminum alloys provide strength and ruggedness while also offering light weight — about one-third the weight of competitive couplings. This means easier handling, longer bearing life, quicker accelerations, and even lower shipping costs. Its high ductility and impact resistance eliminate the brittle fracture characteristics of grey iron and semi-steel. Its resistance to corrosion and its non-sparking characteristics are well known.

**STEEL AND STAINLESS STEEL HUBS** are an available option for the Standard ELASTOMERIC™ Coupling Type EE. Steel hubs provide added strength when the coupling is used in the most rugged applications typical of steel mill service. Type E stainless steel hubs also offer greater resistance to chemical attack from caustics and similar chemicals encountered with the Pulp & Paper processes. Consult KOP-FLEX for price and delivery on Type E Steel Hubs.

**NEMA MOTORS** The ELASTOMERIC™ Coupling, when mounted with either TAPER-LOCK\* or Q-D® bushings, may be used with any standard T-frame AC motor (including high starting-torque types) on which it can be mounted and will transmit the rated motor torque continuously on applications involving 1.0 service factors. When straight finish bores are used,

the larger maximum bore capacity may permit mounting on bigger, more powerful motors, providing coupling load ratings are not exceeded.

**WITH THESE BENEFITS:**

- Non-Lubricated
- Variable Shaft Separations
- Non-Sparking
- Indoor or Outdoor Operation
- 50°F to +175°F Temperature Range
- Horizontal or Vertical Mounting
- Dirty or Sanitary Environments
- Stocked by Power Transmission Distributors

**DROP-OUT SPACERS** primarily engineered for pump applications where easy and fast pump maintenance is a necessity or for any equipment needing a separation between shaft ends. 117 different shaft separation combinations are available using standard components. The configuration permits fast pump maintenance by easily dropping out the lightweight center coupling section. Shaft mounted hubs and coupling alignment are not disturbed.

**AVS PUMP SPACERS** The single-spacer coupling is designed to meet the American Voluntary Standard for chemical pump service, providing 3 1/2" shaft separation. The spacer hub is also designed to drop out through the shaft gap *prior* to dislodging the pump body from the volute, greatly simplifying pump maintenance and providing an easier "swing" as the pump is removed.

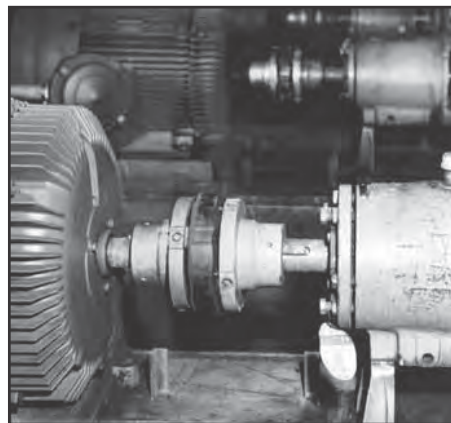

### THEORY OF OPERATION

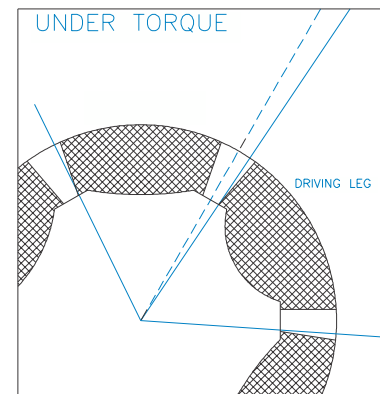
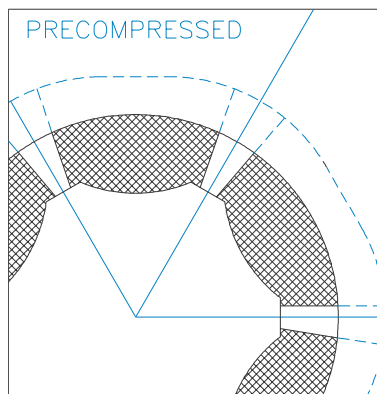
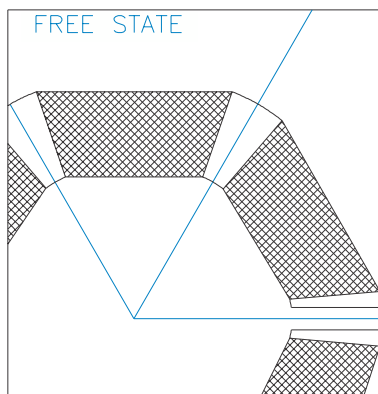

- A. The flexible element in its free state is a polygon.
- B. At assembly, each insert is drawn into its recess in the flange, precompressing each leg, with the element assuming a round shape.
- C. When torque is applied, the driving hub rotates slightly with respect to the driven hub (the torsional load produces a coupling "wind-up"). The driving leg undergoes an increased compression. The trailing leg experiences a reduced compression — but not to the point of going into tension. The flexible element is restrained from radial growth under centrifugal force by the inserts which are bonded within the flexible element and are firmly fastened to each hub.

\* Taper-Lock is believed to be the trademark and/or trade name of Reliance Electric Company, and is not owned or controlled by Emerson Power Transmission.



Values listed are intended only as a general guide, and are typical of usual service requirements. For systems which frequently utilize the peak torque capability of the power source, verify that the magnitude of this peak torque does not exceed the 1.0 Service Factor Rating of the coupling selected. Applications which involve extreme repetitive shock or high-energy load absorption characteristics should be referred — with full particulars — to KOP-FLEX.

Values contained in the table are to be applied to smooth power sources such as electric motors and steam turbines. For drives involving internal combustion engines of four or five cylinders, add 1.0 to the values listed; for six or more cylinders, add 0.5 to the values listed. For systems utilizing AC or DC Mill Motors as the prime mover, refer to Note (1).

**CAUTION:** All people moving plus overhead crane applications must be referred to engineering.

Application	Typical Service Factor
<b>AGITATORS</b>	
Pure Liquids .....	1.0
Liquids & Solids.....	1.25
Liquids — Variable Density .....	1.25
<b>BLOWERS</b>	
Centrifugal.....	1.0
Lobe.....	1.5
Vane.....	1.25
<b>BRIQUETTE MACHINES</b>	2.0
<b>CAR PULLERS — Intermittent Duty</b>	1.5
<b>COMPRESSORS</b>	
Centrifugal.....	1.0
Centriaxial.....	1.25
Lobe.....	1.5
Reciprocating — Multi-Cylinder.....	2.0
<b>CONVEYORS — LIGHT DUTY UNIFORMLY FED</b>	
Apron, Bucket, Chain, Flight, Screw.....	1.25
Assembly, Belt.....	1.0
Oven.....	1.5
<b>CONVEYORS — HEAVY DUTY NOT UNIFORMLY FED</b>	
Apron, Bucket, Chain, Flight, Oven.....	1.5
Assembly, Belt.....	1.25
Reciprocating, Shaker.....	2.5
<b>CRANES AND HOISTS (NOTE 1 and 2)</b>	
Main hoists, Reversing.....	2.5
Skip Hoists, Trolley & Bridge Drives .....	2.0
Slope.....	2.0
<b>CRUSHERS</b>	
Ore, Stone.....	3.0
<b>DREDGES</b>	
Cable Reels.....	1.75
Conveyors .....	1.5
Cutter Head Jig Drives .....	2.5
Maneuvering Winches.....	1.75
Pumps.....	1.75
Screen Drives.....	1.75
Stackers.....	1.75
Utility Winches.....	1.5
<b>ELEVATORS (NOTE 2)</b>	
Bucket.....	1.75
Centrifugal & Gravity Discharge.....	1.5
Escalators.....	1.5
Freight.....	2.5
<b>FANS</b>	
Centrifugal.....	1.0
Cooling Towers.....	1.5
Forced Draft.....	1.5
Induced Draft without Damper Control.....	2.0
<b>FEEDERS</b>	
Apron, Belt, Disc, Screw.....	1.25
Reciprocating.....	2.5

Application	Typical Service Factor
<b>GENERATORS —</b>	
(Not Welding).....	1.0
<b>HAMMER MILLS</b> .....	2.0
<b>LAUNDRY WASHERS —</b>	
Reversing.....	2.0
<b>LAUNDRY TUMBLERS</b> .....	2.0
<b>LINE SHAFT</b> .....	1.5
<b>LUMBER INDUSTRY</b>	
Barkers — Drum Type.....	2.0
Edger Feed.....	2.0
Live Rolls.....	2.0
Log Haul — Incline.....	2.0
Log Haul — Well type.....	2.0
Off Bearing Rolls.....	2.0
Planer Feed Chains.....	1.75
Planer Floor Chains.....	1.75
Planer Tilting Hoist.....	1.75
Stab Conveyor.....	1.5
Sorting Table.....	1.5
Trimmer Feed.....	1.75
<b>MARINE PROPULSION</b>	
Main Drives.....	2.0
<b>MACHINE TOOLS</b>	
Bending Roll.....	2.0
Plate Planer.....	1.5
Punch Press — Gear Driven.....	2.0
Tapping Machines.....	2.5
Other Machine Tools	
Main Drives.....	1.5
Auxiliary Drives.....	1.25
<b>METAL MILLS</b>	
Draw Bench — Carriage.....	2.0
Draw Bench — Main Drive.....	2.0
Forming Machines.....	2.0
Slitters.....	1.5
Table Conveyors	
Non-Reversing.....	2.25
Reversing.....	2.5
Wire Drawing & Flattening Machine.....	2.0
Wire Winding Machine.....	1.75
<b>METAL ROLLING MILLS (NOTE 1)</b>	
Blooming Mills.....*	
Coilers, hot mill.....	2.0
Coilers, cold mill.....	1.25
Cold Mills.....	2.0
Cooling Beds.....	1.75
Door Openers.....	2.0
Draw Benches.....	2.0
Edger Drives.....	1.75
Feed Rolls, Reversing Mills.....	3.5
Furnace Pushers.....	2.5
Hot Mills.....	3.0
Ingot Cars.....	2.5
Kick-outs.....	2.5
Manipulators.....	3.0
Merchant Mills.....	3.0
Piercers.....	3.0
Pusher Rams.....	2.5
Reel Drives.....	1.75
Reel Drums.....	2.0
Reelers.....	3.0
Rod and Bar Mills.....	1.5
Roughing Mill Delivery Table.....	3.0
Runout Tables	
Reversing.....	3.0
Non-Reversing.....	2.0
Saws, hot & cold.....	2.5
Screwdown Drives.....	3.0
Skelp Mills.....	3.0
Slitters.....	3.0
Slabbing Mills.....	3.0
Soaking Pit Cover Drives.....	3.0
Straighteners.....	2.5
Tables, transfer & runout.....	2.0
Thrust Block.....	3.0
Traction Drive.....	3.0
Tube Conveyor Rolls.....	2.5
Unscramblers.....	2.5
Wire Drawing.....	1.5
<b>MILLS, ROTARY TYPE</b>	
Ball.....	2.25
Dryers & Coolers.....	2.0
Hammer.....	1.75
Kilns.....	2.0

Application	Typical Service Factor
Pebble & Rod.....	2.0
Pug.....	1.75
Tumbling Barrels.....	2.0
<b>MIXERS</b>	
Concrete Mixers.....	1.75
Drum Type.....	1.5
<b>OIL INDUSTRY</b>	
Chillers.....	1.25
Paraffin Filter Press.....	1.75
<b>PAPER MILLS</b>	
Barker Auxiliaries, Hydraulic.....	2.0
Barker, Mechanical.....	2.0
Barking Drum Spur Gear Only.....	2.25
Beater & Pulper.....	1.75
Bleacher.....	1.0
Calenders.....	2.0
Chippers.....	2.5
Coaters.....	1.0
Converting Machines, except Cutters, Platers.....	1.5
Couch Roll.....	1.75
Cutters, Platers.....	2.0
Cylinders.....	1.75
Disc Refiners.....	1.75
Dryers.....	1.75
Felt Stretcher.....	1.25
Felt Whipper.....	2.0
Jordans.....	1.75
Line Shaft.....	1.5
Log Haul.....	2.0
Pulp Grinder.....	1.75
Press Roll.....	2.0
Reel.....	1.5
Stock Chests.....	1.5
Suction Roll.....	1.75
Washers & Thickeners.....	1.5
Winders.....	1.5
<b>PRINTING PRESSES</b> .....	1.5
<b>PULLERS — Barge Haul</b> .....	2.0
<b>PUMPS</b>	
Centrifugal.....	1.0
Boiler Feed.....	1.5
Reciprocating	
Single Acting	
1 or 2 Cylinders.....	2.25
3 or more Cylinders.....	1.75
Double Acting.....	2.0
Rotary, Gear, Lobe, Vane.....	1.5
<b>RUBBER INDUSTRY</b>	
Mixer — Banbury.....	2.5
Rubber Calendar.....	2.0
Rubber Mill (2 or more).....	2.25
Sheeter.....	2.0
Tire Building Machines.....	2.5
Tire & Tube Press Openers.....	1.0
Tubers & Strainers.....	2.0
<b>SCREENS</b>	
Air Washing.....	1.0
Grizzly.....	2.0
Rotary — Stone or Gravel.....	1.5
Traveling Water Intake.....	1.25
Vibrating.....	2.5
<b>SEWAGE DISPOSAL EQUIPMENT</b>	
Bar Screens.....	1.25
Chemical Feeders.....	1.25
Collectors, Circuline or Straightline.....	1.25
Dewatering Screens.....	1.25
Grit Collectors.....	1.25
Scum Breakers.....	1.25
Slow or Rapid Mixers.....	1.25
Sludge Collectors.....	1.25
Thickeners.....	1.25
Vacuum Filters.....	1.25
<b>STEERING GEAR</b> .....	1.0
<b>STOKERS</b> .....	1.0
<b>WINCH</b> .....	1.5
<b>WINDLASS</b> .....	1.75

\* Refer to KOP-FLEX

#### NOTES

- (1) Maximum Torque at the coupling must not exceed Rated Torque of the coupling.
- (2) Check local and industrial safety codes.

### 1. Coupling Type:

Select the appropriate ELASTOMERIC™ coupling type for your application.

### 2. Coupling Size:

**Step 1:** Determine the proper service factor from page 72.

**Step 2:** Calculate the required HP/100 RPM, using the HP rating of the drive and the coupling speed (RPM) as shown below:

$$\frac{\text{HP} \times \text{SERVICE FACTOR} \times 100}{\text{RPM}} = \text{HP/100 RPM}$$

**Step 3:** Using Table 1 select the coupling size having a rating sufficient to handle the required HP/100 RPM at the appropriate service factor.

**Step 4:** Verify that the actual coupling speed (RPM) is equal to or less than the maximum allowable speed rating of the coupling.

**Step 5:** Verify that the maximum bore of the coupling selected is equal to or larger than either of the equipment shafts.

Clearance fit bores are acceptable for applications using service factors of 2 or less. For service factors higher than 2, interference fits are recommended.

**Step 6:** Check the overall dimensions to ensure coupling will not interfere with the coupling guard, piping, or the equipment housings and that it will fit the required shaft separation.

**Note:** For reciprocating engines and reciprocating compressor service, refer all application data to KOP-FLEX for selection.

**TABLE 1 — SELECTION DATA — ELASTOMERIC™ COUPLINGS**

Coupling Size	Coupling Rating (1) HP/100 RPM	Torque Rating		Max. RPM (3)	Static Torsional Stiffness (lb.-in./rad.)	Maximum Offset Misalignment Capacity (inches)	Maximum Axial Misalignment Capacity (inches)
		Continuous Duty (lb.-in.)	Peak Load (lb.-in.) (2)				
20	.334	217	630	4100	3180	.029	±.013
30	.664	418	1245	4100	7460	.032	±.017
40	1.15	725	2100	4100	11800	.034	±.019
50	2.00	1260	3630	4100	21600	.036	±.023
60	3.05	1920	5700	4100	42800	.038	±.026
70	7.20	4540	13350	3600	97000	.042	±.030
80	13.0	8190	24270	2800	186000	.056	±.036
90	22.6	14200	42300	2000	284000	.079	±.046
100	42.0	26500	78600	1800	557000	.086	±.052

(1) If actual maximum torque loads are known, do not use Service Factors but rather select coupling size under "Torque Rating" in Table I. These figures are those which the coupling is capable of transmitting under continuous operation and normal alignment so as to be consistent with reasonable industrial service life.

(2) For infrequently applied loads not to exceed once per hour.  
 (3) For higher speeds, refer to KOP-FLEX.

### PART NUMBER EXPLANATION Complete Rough Bore Coupling

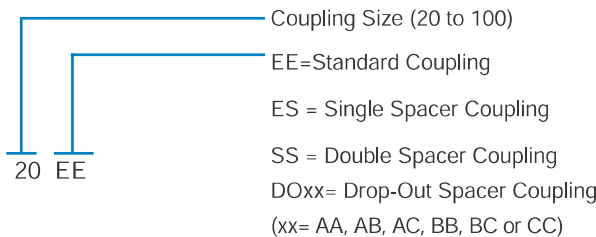

### Coupling Parts

- Description
- EHUB = Standard Hub (Aluminum)
- EHUBXBORE = Standard Hub Finished Bored
- EHUBTLXBUSH = Standard Hub Bored for TAPER-LOCK\*
- EHUBQDXBUSH = Standard Hub Bored for Q-D®
- SHUB = Spacer Hub
- LHUB = Long Hub
- RHUB = Drop-Out Hub
- FS = Fastener Set
- ELEMENT = Element with Fasteners
- AHUB = Spacer Type A Hub with Fasteners
- BHUB = Spacer Type B Hub with Fasteners
- CHUB = Spacer Type C Hub with Fasteners
- ESTEEL HUB = Steel Hub
- ESSTEEL HUB = Stainless Steel Hub

Note: Standard bores are supplied clearance fit with one setscrew over keyway.

example: 20 EHUBX3/4

## How to Order

Visit [www.emerson-ept.com](http://www.emerson-ept.com)

\* Taper-Lock is believed to be the trademark and/or trade name of Reliance Electric Company, and is not owned or controlled by Emerson Power Transmission.

### Standard Coupling Type EE with Finished Straight Bores

Standard Couplings Type EE are generally used on close-connected equipment and may be mounted for either wide or close shaft separations, at the user's option. This permits ready installation on existing shaft separations and eliminates moving the connected equipment to suit the coupling.

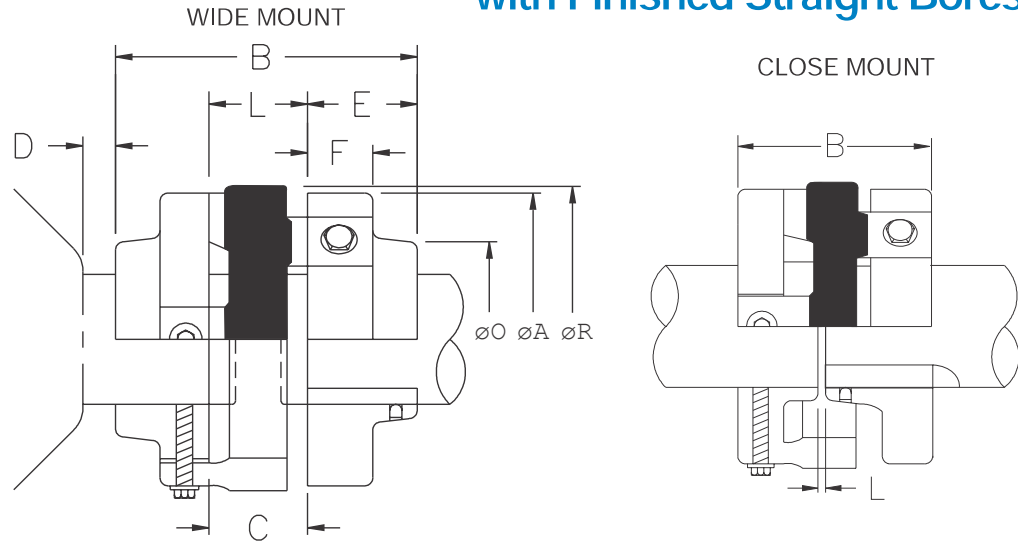

TABLE 1

Coupling Size	WIDE MOUNT												CLOSE MOUNT			
	Bore with Standard Keyway		Stock Rough Bore	Hub Sep. L	Shaft Separation C		ø A	B	D	E	F	ø O	ø R	Coupling Size	Hub & Shaft Separation L	B
	Max.	Min.			Min.	Max.										
20	1 1/8	1/2	3/8	1	1/8	1	3 11/16	3 1/8	1/8	1 1/16	5/8	1 7/8	4	20	1/8	2 1/4
30	1 1/2	1/2	3/8	1 1/2	1/8	1 1/2	4 3/8	4 1/8	1/8	1 5/16	5/8	2 7/16	4 5/8	30	1/8	2 3/4
40	1 7/8	1/2	3/8	1 5/8	1/8	1 5/8	5 3/8	5 1/8	1/8	1 3/4	1	2 3/4	5 11/16	40	1/8	3 5/8
*50	2 1/8	3/4	5/8	2 1/8	1/8	2 1/8	6 1/16	6 1/8	1/8	2	1	3 1/8	6 3/4	50	1/8	4 1/8
*60	2 7/8	1 1/8	15/16	2 1/8	1/8	2 1/8	7	6 1/8	1/8	2	1	4 7/32	7 5/8	60	1/8	4 1/8
70	3	1 1/4	1 1/16	2 3/8	1/8	2 3/8	8	6 5/8	1/8	2 1/8	1	4 7/16	8 11/16	70	1/8	4 3/8
*80	3 3/4	1 1/2	1 1/4	3	1/8	3	9 7/16	8 3/8	1/8	2 11/16	1 1/4	5 5/16	10 1/2	80	1/8	5 1/2
90	4 3/4	1 3/4	1 1/2	4 1/8	1/8	4 1/8	12 1/8	11 1/8	1/8	3 1/2	1 1/2	6 5/8	13 1/16	90	1/8	7 1/8
100	5 3/8	2 1/4	2	4 1/8	1/8	4 1/8	13 7/8	12 1/8	1/8	4	2	7 3/8	15 1/8	100	1/8	8 1/8

NOTES: Finished Bored E Hubs can be ordered by specific Bore size.  
 Complete coupling consists of 2 E Hubs and 1 Replaceable Element.  
 \* 50, 60 and 80 EE hubs are also stocked in steel. Consult KOP-FLEX.

Coupling Size	Complete Coupling No Bore		E Hub No Bore		Element W/ Fastener	
	Part No.	Wt.	Part No.	Wt.	Part No.	Wt.
20	20 EE	2	20 EHUB	1	20 ELEMENT	1
30	30 EE	3	30 EHUB	1	30 ELEMENT	1
40	40 EE	6	40 EHUB	2	40 ELEMENT	1
50	50 EE	9	50 EHUB	3	50 ELEMENT	2
60	60 EE	12	60 EHUB	3	60 ELEMENT	3
70	70 EE	17	70 EHUB	4	70 ELEMENT	5
80	80 EE	31	80 EHUB	8	80 ELEMENT	9
90	90 EE	59	90 EHUB	15	90 ELEMENT	16
100	100 EE	96	100 EHUB	29	100 ELEMENT	18

Standard Hubs are Available From Stock, in Aluminum, Steel and Stainless Steel.

## Long Hub Type L

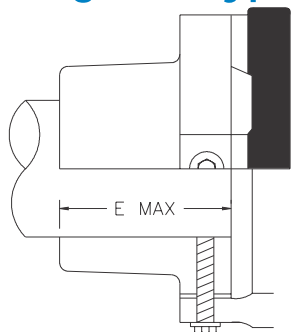

LONG HUB—TYPE L Available for Wide Mount only

### ELASTOMERIC L Hub Rough Bored

Coupling Size	Part No.	EMAX	Bore with Standard Keyway (in.)		Stock Rough Bore
			Min.	Max.	
60	60 LHUB	3 9/16	1 3/8	3	1 1/4
70	70 LHUB	4	1 3/8	3 1/8	1 1/4
80	80 LHUB	4 11/16	1 3/8	4 1/8	1 1/4
90	90 LHUB	4 15/16	1 9/16	4 3/4	1 7/16
100	100 LHUB	5 7/16	2	5 3/8	1 7/8

## Standard Coupling for TAPER-LOCK\* Bushings

1. See opposite table for dimensions not listed.
2. Space is required to remove bushing using shortened hex key cut to minimum usable length for sizes 30 to 80. Sizes 90 and 100 use open end wrench.
3. Maximum bore is the maximum obtained when the bushing is supplied with a reduced shallow keyway. Flat keys are then supplied with the bushing.
4. Intermediate hub separations (L) are obtained by reversing one hub only from the Wide Mount arrangement, giving intermediate maximum hub and shaft separations.

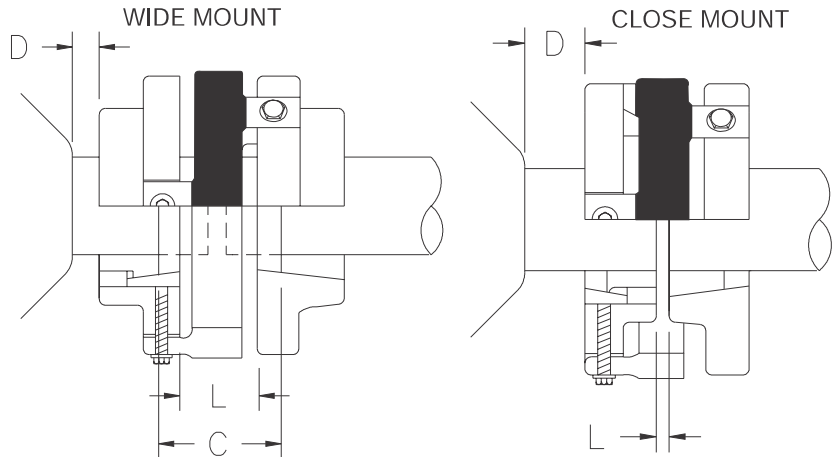

### E Hubs Bored for TAPER-LOCK\* Bushing

Size	Part No.
30	30 EHUBTLX1108
40	40 EHUBTLX1215
50	50 EHUBTLX1615
60	60 EHUBTLX2012
70	70 EHUBTLX2517
80	80 EHUBTLX3020
90	90 EHUBTLX3535
100	100 EHUBTLX3535

Coupling Size	WIDE MOUNT							Coupling Size	CLOSE MOUNT	
	TAPER-LOCK* Bushing		Hub Sep. L	Shaft Separation C		D	Hub and Shaft Separation L		D	
	Number	Bore Min.(in.)		Bore Max.(in.)	Min.					Max.
30	1108	1/2	1 1/8	1 1/2	1/8	2 3/8	3/4	30	1/8	1/8
40	1215	1/2	1 1/8	1 5/8	1/8	3 1/8	1 1/16	40	1/8	1/8
50	1615	1/2	1 5/8	2 1/8	1/8	3 1/8	1 1/16	50	1/8	1/8
60	2012	1/2	2	2 1/8	1/8	3 5/8	1 3/8	60	1/8	1/8
70	2517	1/2	2 1/2	2 3/8	1/8	3 1/8	1 5/8	70	1/8	1/8
80	3020	15/16	3	3	1/8	4 3/8	2 1/16	80	1/8	1/8
90	3535	1 3/16	3 1/2	4 1/8	1/8	4 1/8	1 3/4	90	1/8	1/8
100	3535	1 3/16	3 1/2	4 1/8	1/8	4 1/8	2	100	1/8	1/8

## Standard Coupling for Q-D® Bushings

1. Bushing screws may be inserted from direction opposite to that shown, eliminating need for axial clearance D.

### E Hubs Bored for Q-D® Bushing

Size	Part No.
30	30 EHUBQDXJA
40	40 EHUBQDXJA
50	50 EHUBQDXSH
60	60 EHUBQDXSDS
70	70 EHUBQDXSK
80	80 EHUBQDXSF
90	90 EHUBQDXE
100	100 EHUBQDXF

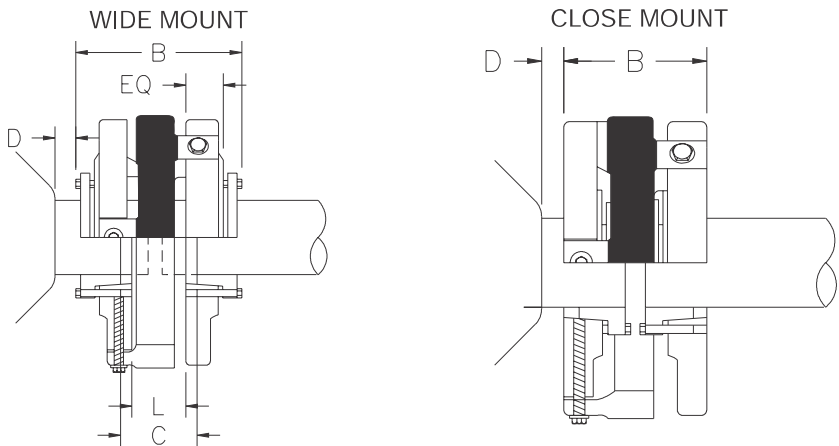

### NET WT, LBS.—STANDARD COUPLINGS

Coupling Size	With Solid Hubs	With Max. Bore and Standard Keyway	With TAPER-LOCK* Bushing (Max. Bore)	With Q-D® Bushing (Max. Bore)
20	1.7	1.6	-	-
30	2.8	2.3	2.7	3.0
40	6.0	5.0	6.2	6.1
50	8.8	7.3	8.4	9.4
60	12.2	9.2	11.8	13.0
70	17.0	13.6	17.1	18.8
80	30.5	23.1	30.8	32.6
90	59.4	45.4	62.0	67.3
100	96.0	76.0	102.0	106

Coupling Size	WIDE MOUNT							CLOSE MOUNT						
	Q-D® Bushing		B	Hub Sep. L	Shaft Sep. C		D	EQ	Coupling Size	Hub Sep. L	Shaft Sep. C	B	D	
	Size	Bore Min.(in.)			Bore Max.(in.)	Min.								Max.
30	JA	1/2	1 1/4	4 1/4	1 1/2	1/8	1 7/8	1 1/8	3/4	30	1 1/4	3/8	2 3/4	1/8
40	JA	1/2	1 1/4	5 1/8	1 5/8	1/8	2 3/4	1 1/8	1 1/8	40	1 3/8	1/2	3 5/8	1/8
50	SH	1/2	1 5/8	6 3/16	2 1/8	1/8	3 1/8	1 9/16	1 1/4	50	1 5/8	1/2	4 1/8	1/8
50	SDS	1/2	1 15/16	6 1/16	2 1/8	1/8	3	1 9/16	1 3/16	60	1 3/4	5/8	4 1/8	1/8
60	SK	1/2	2 1/2	6 9/16	2 3/8	1/8	2 1/8	2 1/4	1 1/8	70	2 1/8	3/4	4 3/8	1/8
80	SF	1/2	2 15/16	8 1/16	3	1/8	3 1/4	2 3/8	1 7/16	80	2 5/8	1 1/8	5 1/2	1/8
90	E	7/8	3 7/16	10 1/2	4 1/8	1/8	4 1/8	3 1/16	1 3/4	90	3 5/8	1 5/8	7 1/8	1/8
100	F	1	3 15/16	12 3/4	4 1/8	1/8	4 1/4	4 3/16	2 5/8	100	-	-	-	-

\* Taper-Lock is believed to be the trademark and/or trade name of Reliance Electric Company, and is not owned or controlled by Emerson Power Transmission.

### Drop-Out Spacer Coupling Type DO

Wherever spacer type couplings are used for motor driven back-pull-out pumps, AVS Pumps, Process Pumps and any application for a Spacer Type coupling. Over 117 shaft separation combinations are available using standard components.

The ELASTOMERIC™ Drop-out coupling provides for easy removal of the pump's back-pull-out section keeping routine pump maintenance and down-time to a minimum.

Upon removal of a few axial fasteners, the flexible coupling center section is easily inserted, or removed to gain pump access.

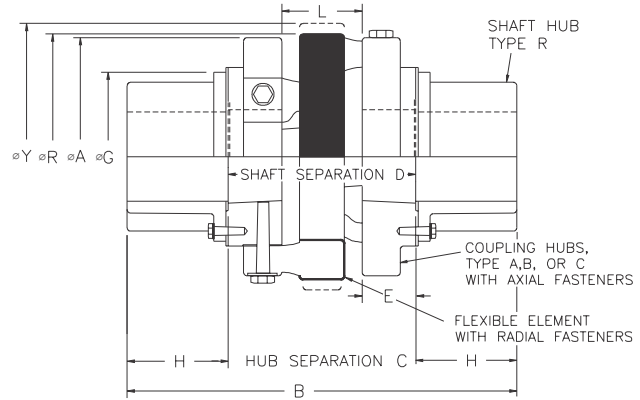

Size	Ratings Centrifugal Pump Service (1)		Max. RPM	Max. Offset	Dimensions (in.)						Rough Bore (in.)
	HP/100 RPM (2)	Torque Lb.-In.			∅A	∅G	H	L	∅R	∅Y	
20	.334	217	4100	.029	3 11/16	3 1/8	1 3/8	1	4	4 1/2	5/8
30	.664	418	4100	.032	4 3/8	3 3/8	1 5/8	1 1/2	4 5/8	5 1/2	5/8
40	1.15	725	4100	.034	5 3/8	3 11/16	1 3/4	1 5/8	5 11/16	6 5/8	5/8
50	2.00	1260	4100	.036	6 1/16	4 7/16	2 3/8	2 1/8	6 3/4	7 3/8	5/8
60	3.05	1920	4100	.038	7	4 15/16	2 5/8	2 1/8	7 5/8	8 3/8	1
70	7.20	4540	3600	.042	8	5 11/16	3	2 3/8	8 11/16	9 3/4	1
80	13.0	8190	2800	.056	9 7/16	7	3 7/8	3	10 1/2	11 3/4	1 1/4
90	22.6	14200	2000	.079	12 1/8	8 1/4	4 1/4	4 1/8	13 1/16	14 3/8	1 1/2

(1) Ratings are for motor driven centrifugal pump and blower service (service factor of 1.0). For other applications, refer to pages 72 & 73 for appropriate service factors and coupling size selection data. Couplings will transmit peak loads of 3 times these values if infrequently applied (not to exceed once per hour).

(2)  $HP/100rpm = \frac{HP \text{ to be transmitted} \times 100}{\text{Coupling rpm}}$

Coupling Size	R Hub			Element W/ Fastener	
	No Bore		Finish Bore ① Part No.	Part No.	Wt.
	Part No.	Wt.			
20	20 RHUB	1	20 RHUB FB	20 ELEMENT	1
30	30 RHUB	1	30 RHUB FB	30 ELEMENT	1
40	40 RHUB	1	40 RHUB FB	40 ELEMENT	1
50	50 RHUB	2	50 RHUB FB	50 ELEMENT	2
60	60 RHUB	3	60 RHUB FB	60 ELEMENT	3
70	70 RHUB	5	70 RHUB FB	70 ELEMENT	5
80	80 RHUB	9	80 RHUB FB	80 ELEMENT	9
90	90 RHUB	15	90 RHUB FB	90 ELEMENT	16

NOTE: ① Finish bores and keyways per AGMA/ANSI 9112 commercial standard tolerances. Each clearance bore includes one set screw over keyway.

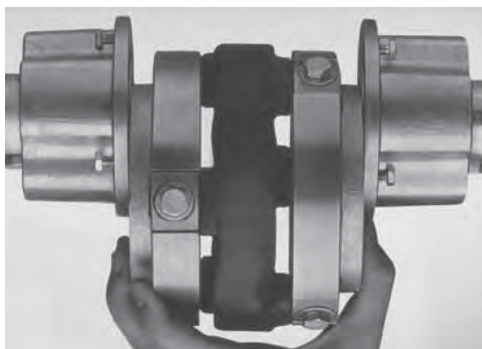
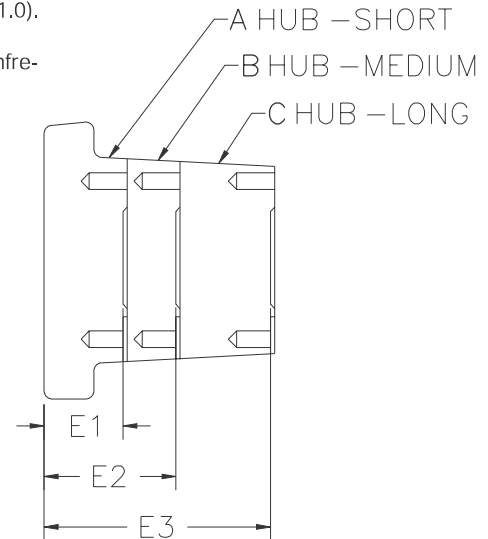

The ELASTOMERIC™ Drop Out Spacer Coupling center section is easily installed as a preassembled unit, or as lightweight component parts. For pump or seal maintenance, the "drop out" center section is easily removed for fast pump access.

### Coupling Hubs Type A, B and C

Size	E DIMENSION (in.)			AXIAL FASTENERS	
	A Hub	B Hub	C Hub	No. Per Hub	Size
	E1	E2	E3		
20	—	1 1/4	2 3/4	4	1/4-20
30	—	1	2 1/2	4	1/4-20
40	1	1 11/16	3 15/16	4	1/4-20
50	1	1 7/16	3 11/16	4	1/4-20
60	1	1 7/16	3 11/16	4	5/16-18
70	1	1 5/16	3 9/16	4	3/8-16
80	1 7/32	2 1/8	4 5/8	6	1/2-13
90	—	1 9/16	4 1/16	6	5/8-11



## Type DO Dimensional and Assembly Data

Coupling Size	No Bore Part Description	Weight (lbs.)	Shaft Hub Type R				Shaft Separation			Quantities Per Assembly								
			Min. Bore	Max. Bore With Std. Kwy (a)	Std. Kwy Size	Dim. B	Min. (2)	Std. (3) Dim. C	Max. (4)	Coupling Hub			Shaft Hub	Flex Elem.				
										Hub A	Hub B	Hub C						
20	20 DOBB	2.0	3/4	1 3/8	5/16 x 5/32	6 1/4	3 7/16	3 1/2	3 3/4	2	1	2	2	1				
	20 DOBC	2.3				7 3/4	4 15/16	5	5 1/4						1	1	2	1
	20 DOCC	2.5				9 1/4	6 7/16	6 1/2	6 3/4						2	2	2	1
30	30 DOBB	2.8	3/4	1 5/8	3/8 x 3/16	6 3/4	3 5/16	3 1/2	3 3/4	2	1	2	2	1				
	30 DOBC	3.2				8 1/4	4 13/16	5	5 1/4						1	1	2	1
	30 DOCC	3.4				9 3/4	6 5/16	6 1/2	6 3/4						2	2	2	1
40	40 DOAA	5.4	3/4	1 3/4	3/8 x 3/16	7 1/8	3 1/2	3 5/8	3 3/4	2	1	2	2	1				
	40 DOAB	5.6				7 13/16	4 3/16	4 5/16	4 1/2						1	1	2	1
	40 DOBB	5.8				8 1/2	4 7/8	5	5 1/4						2	2	2	1
	40 DOAC	6.3				10 1/16	6 7/16	6 9/16	6 7/8						1	1	2	1
	40 DOBC	6.5				10 3/4	7 1/8	7 1/4	7 1/2						1	1	2	1
	40 DOCC	7.1				13	9 3/8	9 1/2	10						1	2	2	1
50	50 DOAA	8.2	3/4	2 3/8	5/8 x 5/16	8 7/8	3 7/8	4 1/8	4 3/8	2	1	2	2	1				
	50 DOAB	8.4				9 5/16	4 9/16	4 5/16	4 13/16						1	1	2	1
	50 DOBB	8.6				9 3/4	4 3/4	5	5 1/4						2	2	2	1
	50 DOAC	9.2				11 9/16	6 9/16	6 13/16	7 1/16						1	1	2	1
	50 DOBC	9.4				12	7	7 1/4	7 1/2						1	1	2	1
	50 DOCC	10.2				14 1/4	9 1/4	9 1/2	10						1	2	2	1
60	60 DOAA	10.0	1 1/8	2 5/8	5/8 x 5/16	9 3/8	3 7/8	4 1/8	4 3/8	2	1	2	2	1				
	60 DOAB	10.2				9 13/16	4 5/16	4 9/16	4 13/16						1	1	2	1
	60 DOBB	10.4				10 1/4	4 3/4	5	5 1/4						2	2	2	1
	60 DOAC	11.2				12 1/16	6 9/16	6 13/16	7 1/16						1	1	2	1
	60 DOBC	11.4				12 1/2	7	7 1/4	7 1/2						1	1	2	1
	60 DOCC	12.3				14 3/4	9 1/4	9 1/2	10						1	2	2	1
70	70 DOAA	15.2	1 1/8	3	3/4 x 3/8	10 3/8	4 5/16	4 3/8	4 5/8	2	1	2	2	1				
	70 DOAB	15.4				10 11/16	4 5/8	4 11/16	4 15/16						1	1	2	1
	70 DOBB	15.6				11	4 15/16	5	5 1/4						2	2	2	1
	70 DOAC	16.6				12 15/16	6 7/8	6 15/16	7 3/16						1	1	2	1
	70 DOBC	16.8				13 1/4	7 3/16	7 1/4	7 1/2						1	1	2	1
	70 DOCC	18.0				15 1/2	9 7/16	9 1/2	10						1	2	2	1
80	80 DOAA	26.3	1 3/8	3 3/4	7/8 x 7/16	13 3/16	5 1/4	5 7/16	5 3/4	2	1	2	2	1				
	80 DOAB	26.9				14 3/32	6 5/32	6 21/32	6 13/16						1	1	2	1
	80 DOBB	27.6				15	7 1/16	7 1/4	7 1/2						2	2	2	1
	80 DOAC	28.9				16 19/32	8 21/32	8 27/32	9 3/32						1	1	2	1
	80 DOBC	29.6				17 1/2	9 9/16	9 3/4	10						1	1	2	1
	80 DOCC	31.7				20	12 1/16	12 1/4	12 1/2						1	2	2	1
90	90 DOBB	51.0	1 5/8	4 1/4	1 x 1/2	16 1/4	6 5/8	7 1/4	7 1/2	2	1	2	2	1				
	90 DOBC	53.8				18 3/4	9 1/8	9 3/4	10						1	1	2	1
	90 DOCC	56.6				21 1/4	11 5/8	12 1/4	12 1/2						2	2	2	1

Two shaft hubs (type R) will always be supplied unless ordered "LESS SHAFT HUBS".

- (1) All finish bores will be for clearance fit with set screw over the keyway unless ordered otherwise.
- (2) Minimum shaft separation is obtained by allowing the shafts to protrude slightly beyond the faces of the type R shaft hubs. Hub separation C and dimension L must be maintained as listed.
- (3) Standard shaft separations are obtained when type R shaft hubs are mounted flush with shaft ends. In this case the shaft separation is the same as the hub separation, dimension C.
- (4) Maximum shaft separation is obtained by allowing type R shaft hubs to slightly overhang their shafts. Maximum hub separations tabulated, are based on an overhang of 1/4" or less per hub. Excessive shaft hub overhang increases hub and key stresses.
- (5) Interference fits up to .0005"/in. of shaft diameter are permissible providing maximum bore with interference fit is 1/4" less than maximum clearance fit bore indicated by note (a).
- (6) Weight shown is total coupling weight based on maximum bore.

### Double Spacer Coupling Type SS Single Spacer Coupling Type ES

Spacer Couplings are commonly used where a larger-than-normal shaft separation is desired. This permits servicing of impellers, packing glands, seals, bearing, etc. without disturbing the connected equipment. The two types of spacer couplings—Double Spacer and Single Spacer—vary only in the number of spacer hubs used and offer the user a wide variety of possible shaft separations.

TYPE SS  
DOUBLE SPACER COUPLING

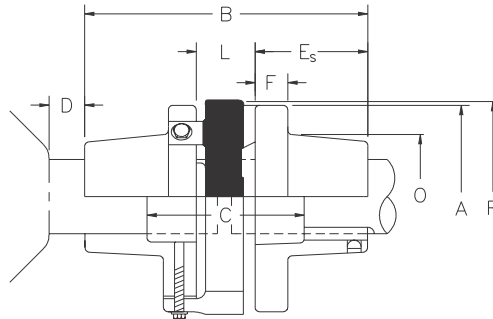

TYPE ES  
SINGLE SPACER COUPLING

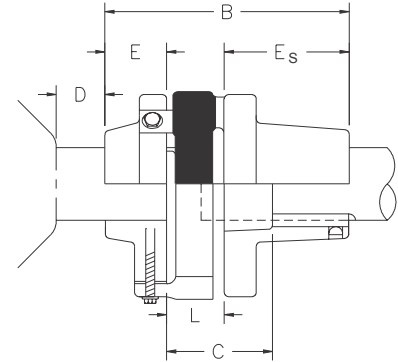

#### DOUBLE SPACER COUPLING With Finished Straight Bores

Coupling Size	Bore with Standard Keyway		Stock Rough Bore S Hub	Hub Sep. L	Shaft Separation C		A	B	D	Es	F	O	R
	Min.	Max.			Min.	Max.							
20	3/4	1 1/4	19/32	1	1/8	6	3 11/16	7 7/8	1/8	3 7/16	5/8	2 5/8	4
30	7/8	1 5/8	3/4	1 1/2	1/8	5 1/2	4 3/8	8 3/8	1/8	3 7/16	5/8	2 13/16	4 5/8
40	7/8	2	3/4	1 5/8	1/8	5 3/8	5 3/8	8 1/2	1/8	3 7/16	1	3 3/16	5 11/16
50	7/8	2 1/4	3/4	2 1/8	1/8	5	6 1/16	9	1/8	3 7/16	1	3 3/8	6 3/4
60	1 1/4	3	1 1/8	2 1/8	1/8	5 1/4	7	9 1/4	1/8	3 9/16	1	4 5/16	7 5/8
70	1 5/8	3 1/8	1 1/2	2 3/8	1/8	6 1/8	8	10 3/8	1/8	4	1	4 9/16	8 11/16
80	1 7/8	4 1/8	1 3/4	3	1/8	7	9 7/16	12 3/8	1/8	4 11/16	1 1/4	5 3/4	10 1/2
90	2 5/8	4 3/4	2 1/2	4 1/8	1/8	7	12 1/8	14	1/8	4 15/16	1 1/2	6 3/4	13 1/16
100	2 7/8	5 3/8	2 3/4	4 1/8	1/8	7	13 7/8	15	1/8	5 7/16	2	7 1/2	15 1/8

#### SINGLE SPACER COUPLING With Finished Straight Bores

Coupling Size	Hub Sep. L	Shaft Separation C		B	E	D
		Min.	Max.			
20	1	1/8	3 1/2	5 1/2	1 1/16	1/8
30	1 1/2	1/8	3 1/2	6 1/4	1 5/16	1/8
40	1 5/8	1/8	3 1/2	6 13/16	1 3/4	1/8
50	2 1/8	1/8	3 9/16	7 9/16	2	1/8
60	2 1/8	1/8	3 11/16	7 11/16	2	1/8
70	2 3/8	1/8	4 1/4	8 1/2	2 1/8	1/8
80	3	1/8	5	10 3/8	2 11/16	1/8
90	4 1/8	1/8	5 9/16	12 9/16	3 1/2	1/8
100	4 1/8	1/8	5 9/16	13 9/16	4	1/8

Coupling Size	S Hub No Bore		E Hub No Bore		Element W/ Fastener	
	Part No.	Wt. (lbs.)	Part No.	Wt. (lbs.)	Part No.	Wt. (lbs.)
20	20 SHUB	1	20 EHUB	1	20 ELEMENT	1
30	30 SHUB	1	30 EHUB	1	30 ELEMENT	1
40	40 SHUB	2	40 EHUB	2	40 ELEMENT	1
50	50 SHUB	3	50 EHUB	3	50 ELEMENT	2
60	60 SHUB	4	60 EHUB	3	60 ELEMENT	3
70	70 SHUB	6	70 EHUB	4	70 ELEMENT	5
80	80 SHUB	11	80 EHUB	8	80 ELEMENT	9
90	90 SHUB	18	90 EHUB	15	90 ELEMENT	16
100	100 SHUB	34	100 EHUB	29	100 ELEMENT	18

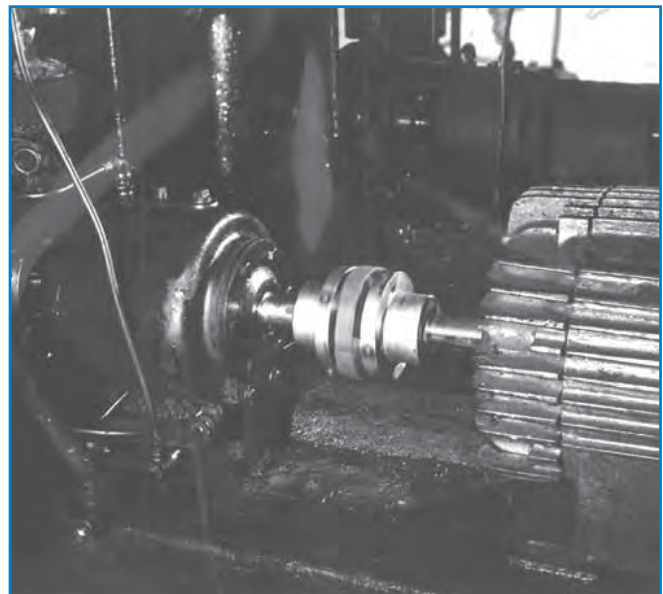

### Spacer Coupling for TAPER-LOCK\* Bushing

1. See table on page 80 for dimensions not listed.
2. Maximum bore is the maximum obtained when the bushing is supplied with a shallow keyway. Flat keys are then supplied with the bushing.

3. Space is required to remove bushing using shortened hex key cut to maximum usable length for sizes 30 to 80. Sizes 90 and 100 use open end wrench.

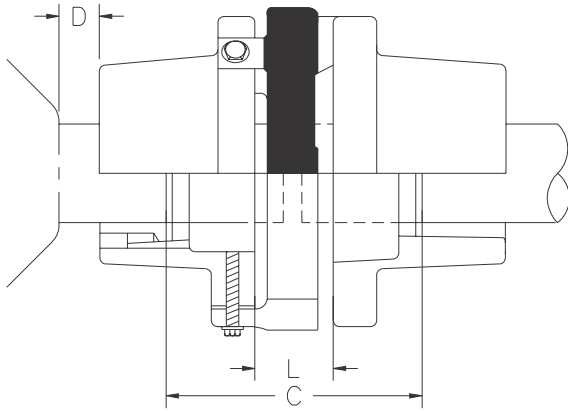

Double Spacer Coupling for TAPER-LOCK\* Bushings

Coupling Size	TAPER-LOCK* Bushing		Hub Sep. L	Shaft Sep. C		D	
	Number	Bore Min. (in.)		Bore Max. (in.)	Min. (in.)		Max. (in.)
30	1108	1/2	1 1/8	1 1/2	1/8	6 5/8	3/4
40	1215	1/2	1 1/4	1 5/8	1/8	6 1/2	1 1/16
50	1615	1/2	1 5/8	2 1/8	1/8	6	1 1/1
60	2012	1/2	2	2 1/8	1/8	6 1/2	1 3/8
70	2517	1/2	2 1/2	2 3/8	1/8	6 7/8	1 5/8
80	3020	15/16	3	3	1/8	8 3/8	2 1/16
90	3535	1 3/16	3 1/2	4 1/8	1/8	7	1 3/4
100	3535	1 3/16	3 1/2	4 1/8	1/8	7	2

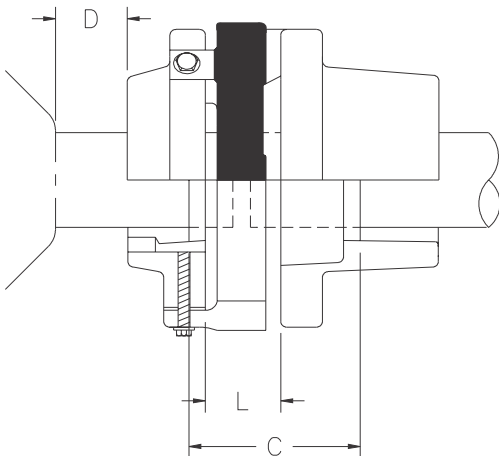

Single Spacer Coupling for TAPER-LOCK\* Bushings

Coupling Size	Shaft Sep. C		D
	Min. (in.)	Max. (in.)	
30	1/8	4 1/2	3/4
40	1/8	4 13/16	1 1/16
50	1/8	4 9/16	1 1/16
60	1/8	5 1/16	1 3/8
70	1/8	5	1 5/8
80	1/8	6 3/8	2 1/16
90	1/8	5 9/16	1 3/4
100	1/8	5 9/16	2

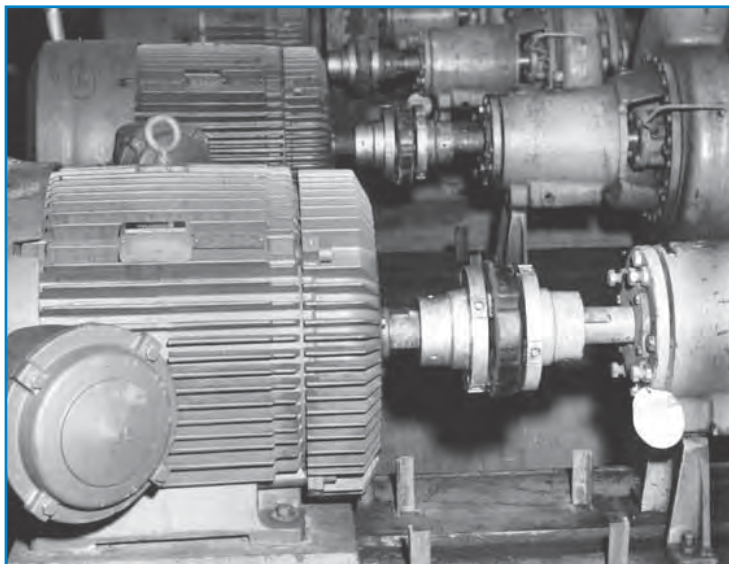

Hubs Bored for TAPER-LOCK\* Bushings

Coupling Size	S Hub Part No.	E Hub Part No.	Element W/ Fasteners	
			Part No.	Wt. (lbs.)
30	30 SHUBTLX1108	30 EHUBTLX1108	30 ELEMENT	1
40	40 SHUBTLX1215	40 EHUBTLX1215	40 ELEMENT	1
50	50 SHUBTLX1615	50 EHUBTLX1615	50 ELEMENT	2
60	60 SHUBTLX2012	60 EHUBTLX2012	60 ELEMENT	3
70	70 SHUBTLX2517	70 EHUBTLX2517	70 ELEMENT	5
80	80 SHUBTLX3020	80 EHUBTLX3020	80 ELEMENT	9
90	90 SHUBTLX3535	90 EHUBTLX3535	90 ELEMENT	16
100	100 SHUBTLX3535	100 EHUBTLX3535	100 ELEMENT	18

\* Taper-Lock is believed to be the trademark and/or trade name of Reliance Electric Company, and is not owned or controlled by Emerson Power Transmission.

1. See table of Finished Straight Bores on page 74 for dimensions not listed.

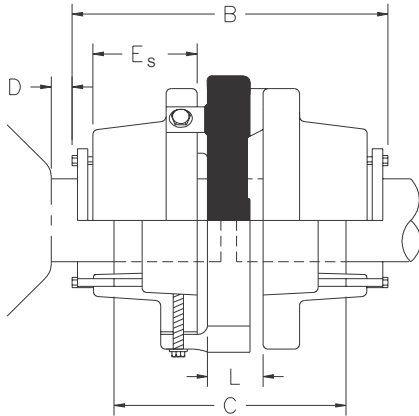

Double Spacer Coupling for Q-D® Bushings

Coupling Size	Q-D® Bushing		Hub Sep. L	Shaft Sep. C		B	D	Es
	Number	Bore Min. (in.)		Bore Max. (in.)	Min. (in.)			
30	JA	1/2	1 1/4	1 1/2	1/8	7 1/4	1 1/8	3 7/16
40	JA	1/2	1 1/4	1 5/8	1/8	7 3/8	1 1/8	3 7/16
50	SH	1/2	1 5/8	2 1/8	1/8	7 1/2	10 9/16	3 7/16
60	SDS	1/2	1 15/16	2 1/8	1/8	7 3/4	10 13/16	3 9/16
70	SK	1/2	2 1/2	2 3/8	1/8	7 7/8	12 5/16	4
80	SF	1/2	2 15/16	3	1/8	9 3/4	14 9/16	4 11/16
90	E	7/8	3 7/16	4 1/8	1/8	10 1/2	16 7/8	4 15/16
100	F	1	3 15/16	4 1/8	1/8	9 7/8	18 3/8	5 7/16

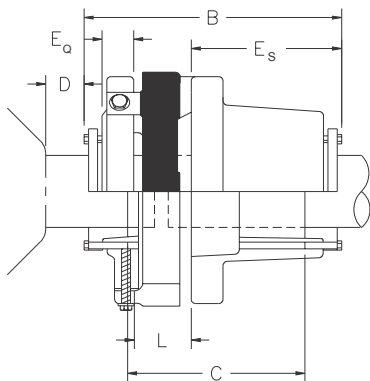

Single Spacer Coupling for Q-D® Bushings

Coupling Size	Shaft Sep. C		B	D	Eq
	Min. (in.)	Max. (in.)			
30	1/8	4 9/16	6 15/16	1 1/8	3/4
40	1/8	5 1/16	7 7/16	1 1/8	1 1/8
50	1/8	5 5/16	8 3/8	1 9/16	1 1/4
60	1/8	5 3/8	8 7/16	1 9/16	1 3/16
70	1/8	5	9 7/16	2 1/4	1 1/8
80	1/8	6 1/2	11 5/16	2 3/8	1 7/16
90	1/8	7 5/16	13 11/16	3 1/16	1 3/4
100	1/8	7 1/16	15 9/16	4 3/16	2 5/8

Hubs Bored for Q-D® Bushings

Coupling Size	S Hub Part No.	E Hub Part No.	Element W/ Fasteners	
			Part No.	Wt. (lbs.)
30	30 SHUBQDXJA	30 EHUBQDXJA	30 ELEMENT	1
40	40 SHUBQDXJA	40 EHUBQDXJA	40 ELEMENT	1
50	50 SHUBQDXSH	50 EHUBQDXSH	50 ELEMENT	2
60	60 SHUBQDXSDS	60 EHUBQDXSDS	60 ELEMENT	3
70	70 SHUBQDXSK	70 EHUBQDXSK	70 ELEMENT	5
80	80 SHUBQDXSF	80 EHUBQDXSF	80 ELEMENT	9
90	90 SHUBQDXE	90 EHUBQDXE	90 ELEMENT	16
100	100 SHUBQDXF	100 EHUBQDXF	100 ELEMENT	18

### NET WEIGHT, LBS.—SPACER COUPLINGS

		Coupling Size	20	30	40	50	60	70	80	90	100
DOUBLE SPACER	With Solid Hubs		4.0	4.6	7.4	10.1	13.9	22.5	41.1	73.2	116
	With Max. Bore and Standard Keyway		3.7	4.1	6.5	8.7	11.1	19.0	34.0	58.8	96
	With TAPER-LOCK* Bushing (Max. Bore)		-	4.5	7.0	9.8	13.5	22.5	41.4	76.4	113
	With Q-D® Bushing (Max. Bore)		-	4.6	7.4	10.3	14.1	23.1	41.3	77.1	122
SINGLE SPACER	With Solid Hubs		2.8	3.7	6.7	9.5	13.0	19.8	35.8	66.3	106
	With Max. Bore and Standard Keyway		2.6	3.2	5.7	8.0	10.1	16.3	28.5	52.1	86
	With TAPER-LOCK* Bushing (Max. Bore)		-	3.6	6.2	9.1	12.7	19.8	36.1	69.2	107
	With Q-D® Bushing (Max. Bore)		-	3.8	6.8	9.9	13.6	21.0	37.0	72.2	114

\* Taper-Lock is believed to be the trademark and/or trade name of Reliance Electric Company, and is not owned or controlled by Emerson Power Transmission.



Mill motor Couplings are for use on AC or DC Mill-Type Motors. Couplings sizes are pre-selected in the table below on the basis of **MAXIMUM MOTOR TORQUE**. Coupling selections should be made directly from the table. **DO NOT USE SERVICE FACTORS.**

**NOTE:** Part Numbers for the ELASTOMERIC™ Mill Motor Couplings have not been established due to the wide variety of mill motor frames.

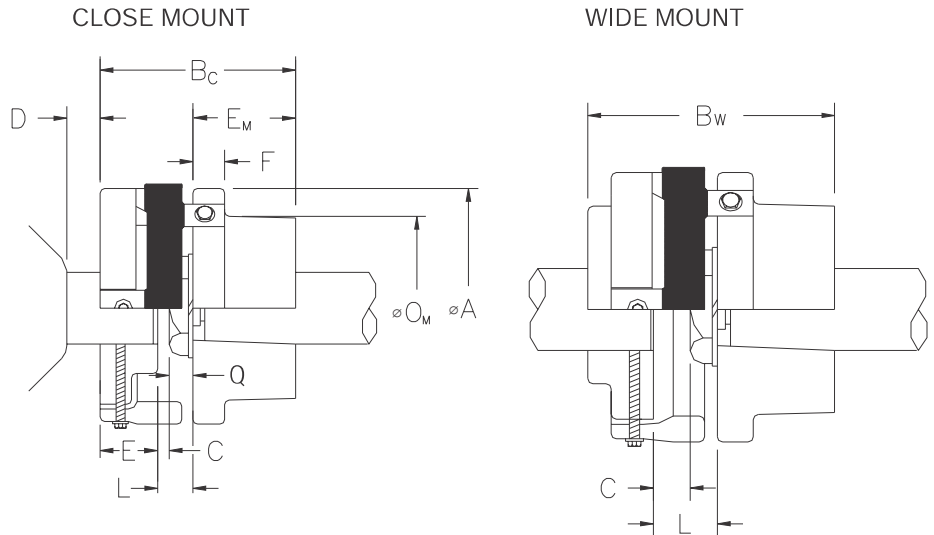

Coupling Size	AISE Frame Number				Bore with Standard Keyway		Close Mount		Wide Mount		Dimension (in.)												
	AC Series	400 Series	600 Series	800 Series	Min. (in.)	Max. (in.)	Hub Sep. L	Shaft Sep. C	Hub Sep. L	Shaft Sep. C		A	Bc	Bw	D	E	Em	F	Om	Q	U	V	Y
										Min. (in.)	Max. (in.)												
60	AC1,AC2	2	2	802A	1 3/8	2 7/8	1 1/8	3/16	2 1/8	1/8	1 3/16	7	6 1/8	7 1/8	1/8	2	3	1	4 5/16	15/16	1 3/4	2 3/4	1 3/16
70	AC4	402	602	802B,C	1 3/8	3	1 1/4	5/16	2 3/8	1/8	1 7/16	8	6 3/8	7 1/2	1/8	2 1/8	3	1	4 9/16	15/16	1 3/4	2 3/4	1 3/16
	AC8	403	603		1 3/8	3	1 1/4	1/4	2 3/8	1/8	1 3/8	8	6 7/8	8	1/8	2 1/8	3 1/2	1	4 9/16	1	2	3 1/4	1 1/4
80	AC12	404	604	803,804	1 3/8	3 7/8	1 9/16	9/16	3	1/8	2	9 7/16	7 3/4	9 3/16	1/8	2 11/16	3 1/2	1 1/4	5 3/4	1	2	3 1/4	1 1/4
					1 3/8	3 7/8	1 9/16	7/16	3	1/8	1 7/8	9 7/16	8 1/4	9 3/16	1/8	2 11/16	4	1 1/4	5 3/4	1 1/8	2 1/2	3 3/4	1 3/8
90	AC18	406	606	806	1 9/16	4 3/4	2 1/8	1	4 1/8	1/8	3	12 1/8	9 5/8	11 5/8	1/8	3 1/2	4	1 1/2	6 3/4	1 1/8	2 1/2	3 3/4	1 3/8
					1 9/16	4 3/4	2 1/8	3/4	4 1/8	1/8	2 3/4	12 1/8	10 1/8	12 1/8	1/8	3 1/2	4 1/2	1 1/2	6 3/4	1 3/8	3 1/4	4 1/4	1 5/8
100	AC25	408	608	808	2	5 3/8	2 1/8	7/8	4 1/8	1/8	2 7/8	13 7/8	10 5/8	12 5/8	1/8	4	4 1/2	2	7 1/2	1 1/4	3	4 1/4	1 1/2
		410	610		2	5 3/8	2 1/8	3/4	4 1/8	1/8	2 3/4	13 7/8	10 5/8	12 5/8	1/8	4	4 1/2	2	7 1/2	1 3/8	3 1/4	4 1/4	1 5/8
					2	5 3/8	2 1/8	5/8	4 1/8	1/8	2 5/8	13 7/8	11 1/8	13 1/8	1/8	4	5	2	7 1/2	1 1/2	3 5/8	4 1/4	1 3/4

\* DO NOT USE SERVICE FACTORS WHEN SELECTING COUPLINGS FROM THIS TABLE

#### Net Weight, Lbs.

Coupling Size	Mill Motor Hub Bored For AISE Motor Frame	Net Weight, Lbs.	
		With Solid Hubs	With Max. Bore Standard Key
60	2,802A AC1,AC2	13.3	11.1
70	602,802B 802C,AC4	18.6	16.2
70	603	19.4	16.6
70	AC8	20.2	16.6
80	604,803 804	31.4	26.5
80	AC12	32.8	27.1
90	606,806	56.1	47.1
90	AC18	57.7	47.1
100	608,808	83.5	70.3
100	610	83.5	69.9
100	AC25	85.6	71.3

**TAPERED BORES** For Tapered Shafts, with or without locknut, determine applicable AISE Mill Motor frame or give data below:

1. U Major diameter.
2. V Length of tapered portion of shaft.
3. X Length to face of lockwasher.
4. Y Length of threaded projection.
5. ZW Locknut diameter across corners.
6. W Clearance to bearing housing.
7. Taper (inches on diameter per foot of length).
8. Keyway width and depth.
9. Whether keyway is parallel to shaft or to taper.
10. C Shaft separation if machines are in place.

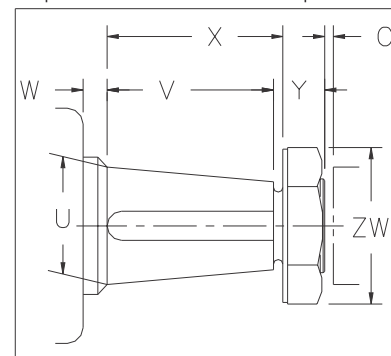

#### ELASTOMERIC™ Coupling for Runout Table Application

We have some exciting field test results run by a major steel mill customer. As you may know our ELASTOMERIC™ couplings are used throughout industry primarily in pump applications as well as runout (also known as entry/exit/transfer table) applications in hot strip steel mills.

NATIONAL STEEL\* Corporation in Granite City ran a grueling test of Elastomer type couplings on their hot strip mill finishing stand runout tables, between the motor and rolls, with our ELASTOMERIC™, FALK\* TORUS\*, DODGE\* PARA-FLEX\*, ATRA-FLEX\* and REXNORD\* OMEGA\* over a four month period. Our size number 60 ELASTOMERIC™ coupling with steel hubs (available as an option, standard hubs are Aluminum) outlasted all of the others. Our ELASTOMERIC™ couplings have been selected as the coupling of choice at GRANITE CITY\* STEEL, on runout table application, after the side by side 'shootout' with our competitors. Price was not the reason we were selected - a case in point - performance outweighing the price!

Just to give you a scope of this success, in a typical hot strip mill there are somewhere between 100 to 300 table rolls - most are motorized - and each driven roll needs a coupling between the motor and the roll. Besides GRANITE CITY STEEL, we have many other applications with ELASTOMERIC™ coupling on runout table such as LTV\* STEEL (Cleveland), WHEELING-PITTSBURGH\* STEEL, ARMCO\* STEEL, WEIRTON STEEL CORPORATION\*, ALGOMA STEEL\*, NORTH STAR BLUESCOPE\*, and the list goes on.

ELASTOMERIC™ couplings have several features :

- Never needs lubrication
- Easy to install - wrap around rubber element allows replacement without removing the connected equipment
- Drives through compression - avoids the pitfalls of other rubber/urethane couplings in shear

Besides the ELASTOMERIC™ coupling the other

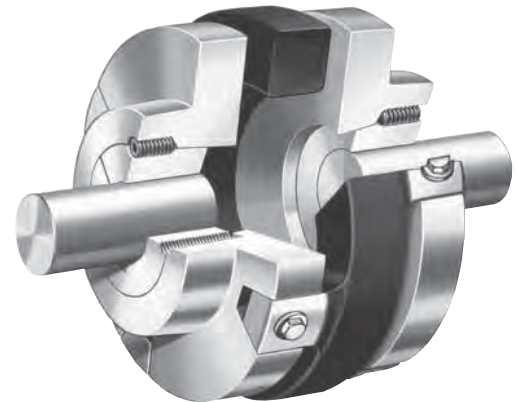

ELASTOMERIC™ Coupling for Runout table (shown under the guard) at a major hot strip steel mill

popular choice for the runout table application is the FAST'S® gear coupling from KOP-FLEX® brand couplings with its unique metal seal design.

\* The following are believed to be the trademarks and/or trade names of their respective owners, and are not owned or controlled by Emerson Power Transmission. Algoma Steel: Essar Steel Algoma, Inc.; Armco: AK Steel Corporation; Atra-Flex: ATR Sales, Inc.; BlueScope: BlueScope Steel Limited; Dodge and Para-Flex: Reliance Electric Company; Falk, Omega, Rexnord and Torus: Rexnord Industries LLC; Granite City and National Steel: National Steel Corporation; LTV: LTV Steel Company, Inc.; Weirton Steel Corporation: Weirton Steel Corporation; Wheeling-Pittsburgh: Severstal Wheeling, Inc.