

# SWITCHBACK 2-LEG 3-STAGE ASSEMBLY INSTRUCTIONS

**IMPORTANT: PLEASE READ ALL INSTRUCTIONS BEFORE STARTING ASSEMBLY.**

## FINAL ASSEMBLY EXAMPLE

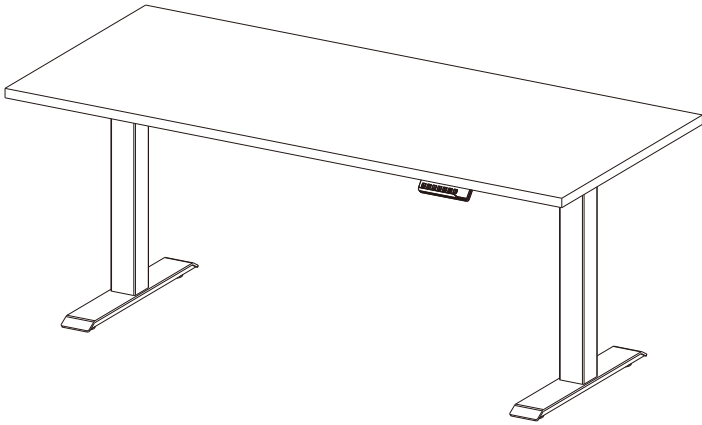

## REQUIRED TOOLS

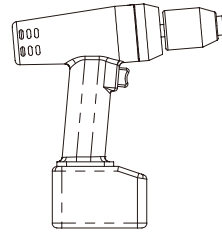

Cordless Drill/Driver

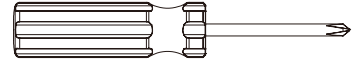

#2 Phillips Screwdriver or Bit

## COMPONENTS

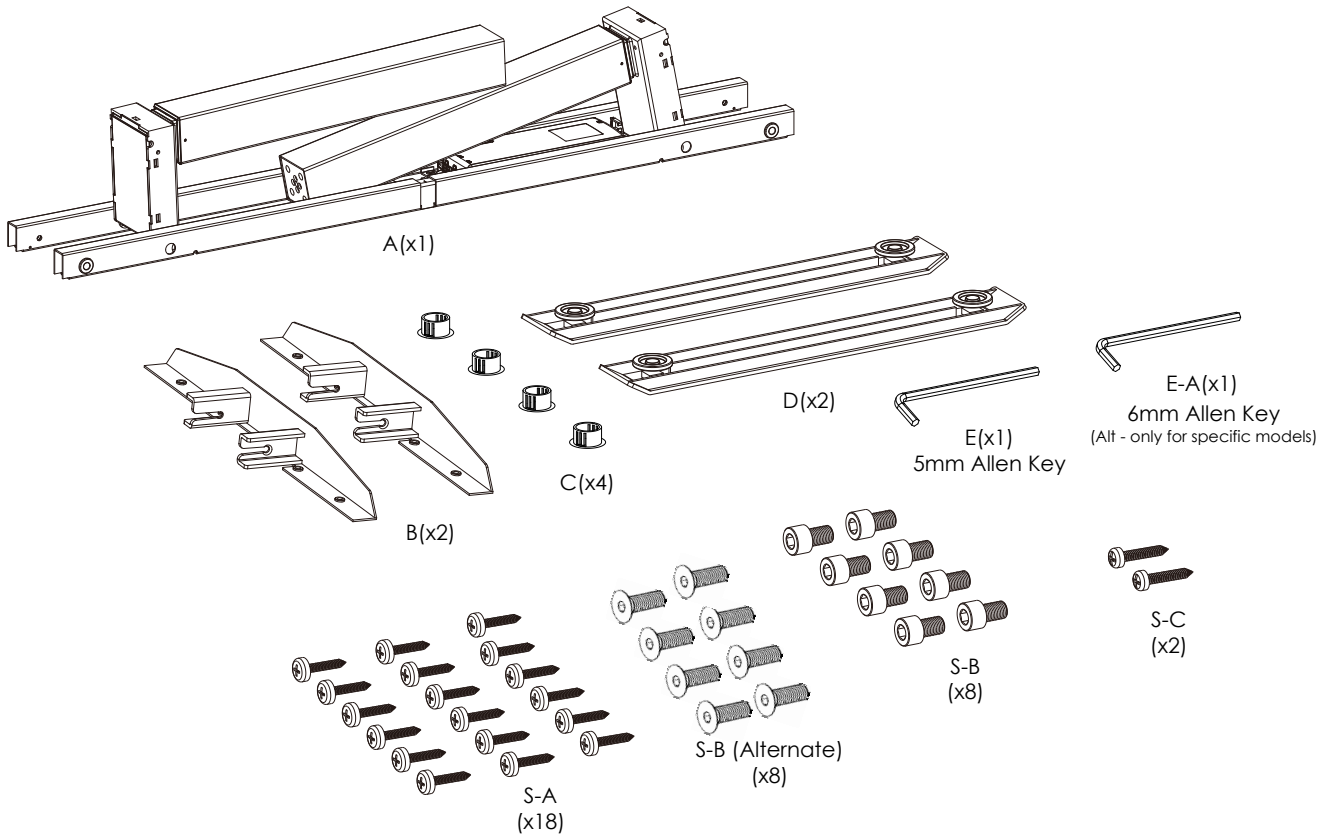

## 1:1 SCALE



M5x20mm Screw  
S-A

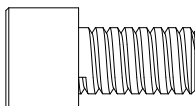

M10x16mm Screw  
S-B

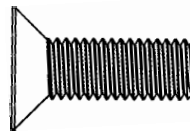

M10x30mm Screw  
S-B (Alternate)



M4x22mm Screw  
S-C

To report any issues with this product, please contact our customer service department at (888) 552-5699.

# SWITCHBACK 2-LEG 3-STAGE ASSEMBLY INSTRUCTIONS

1

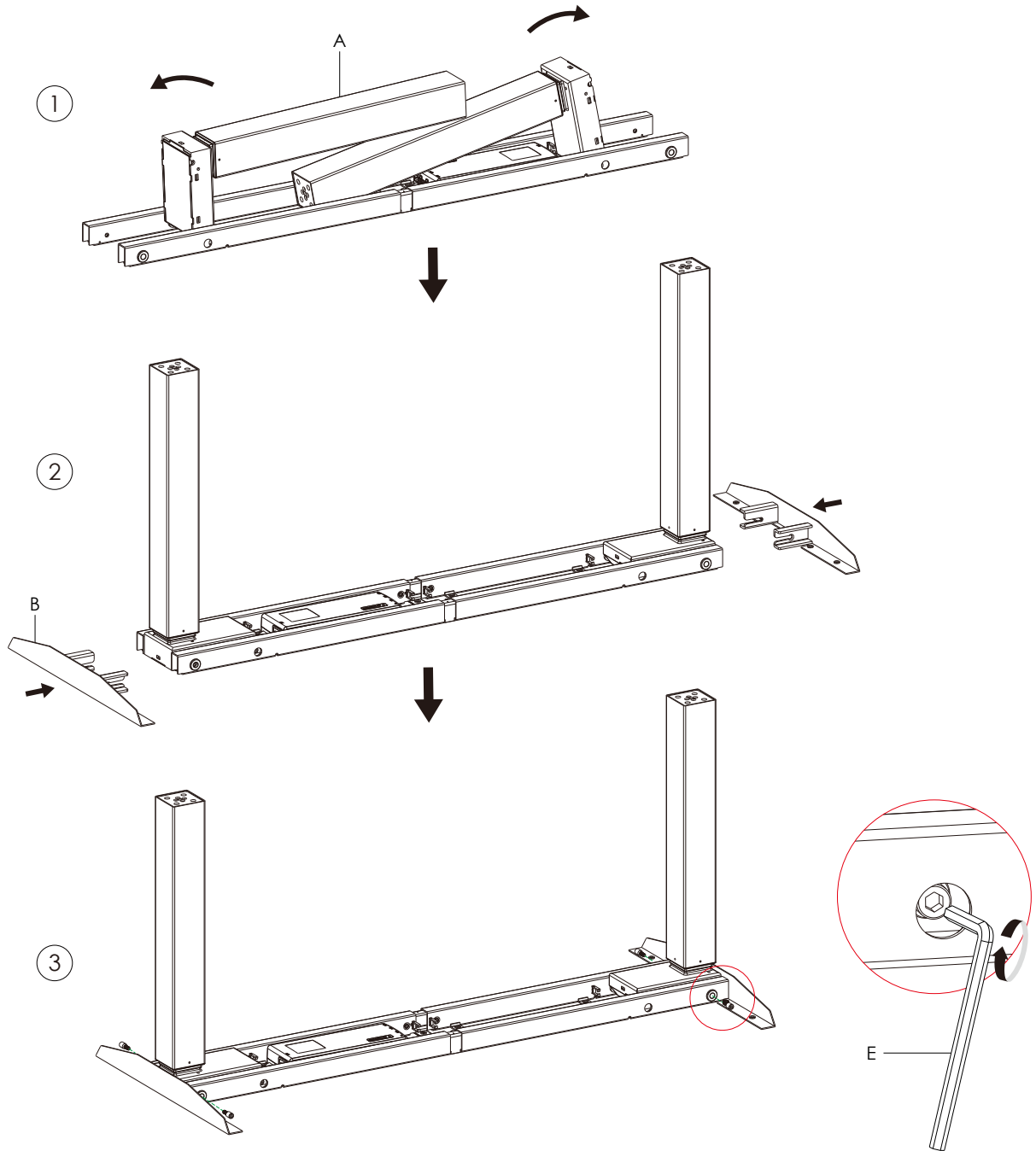

1. Rotate the columns into upright position.
2. Install end pipes into columns.
3. Tighten the 4 bolts (already in place) on each side that secure the motor housing for each of the columns using the Allen wrench provided.

To report any issues with this product, please contact our customer service department at (888) 552-5699.

# SWITCHBACK 2-LEG 3-STAGE ASSEMBLY INSTRUCTIONS

2

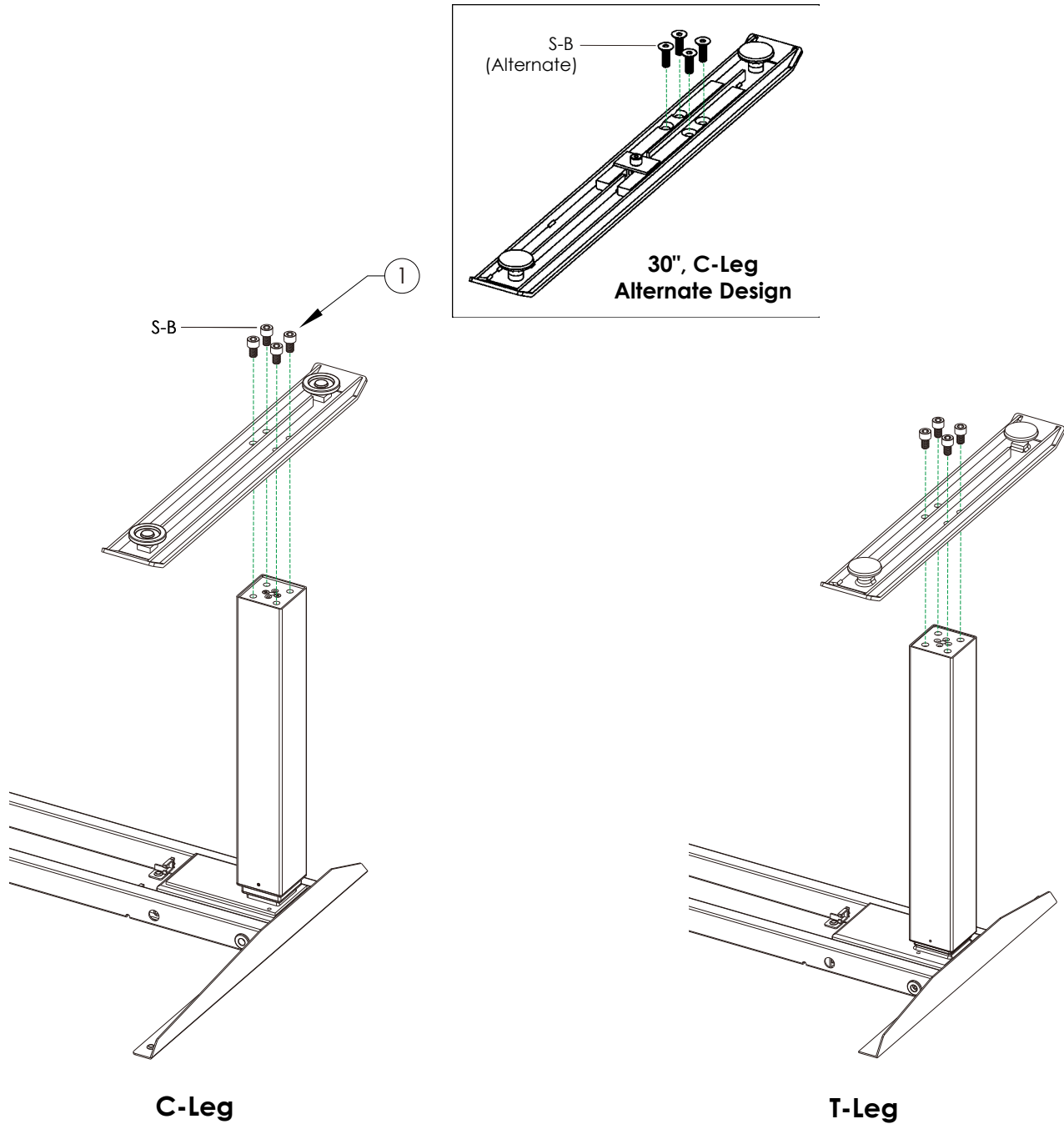

1. Install table feet using 4 screws per leg (M10x16mm) with provided Allen key.

**Note:** For C-Leg make sure the end pipes and feet are extended in the same direction.

To report any issues with this product, please contact our customer service department at (888) 552-5699.

# SWITCHBACK 2-LEG 3-STAGE ASSEMBLY INSTRUCTIONS

3

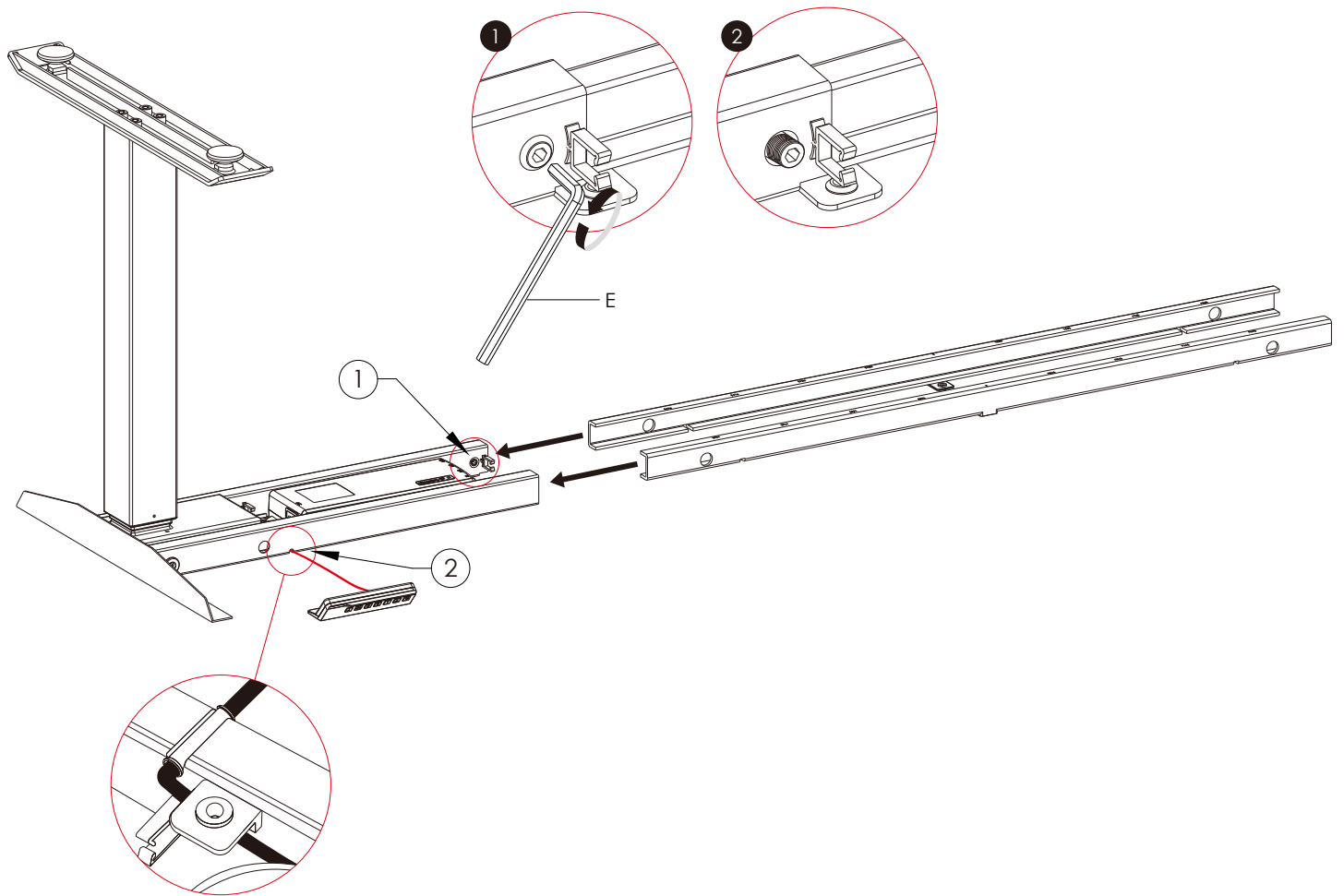

1. Place the frame assembly onto the underside of the table top. Extend the frame to the desired length (This may require loosening of set screws in base assembly using the provided Allen wrench). Once the legs are located, center the U-Pipe and tighten the set screws as shown in the illustration.
2. Connect the handset to the control box. Tuck the control box cord through the frame notch. **Note:** This must be done before securing base to top.

To report any issues with this product, please contact our customer service department at (888) 552-5699.

# SWITCHBACK 2-LEG 3-STAGE ASSEMBLY INSTRUCTIONS

4

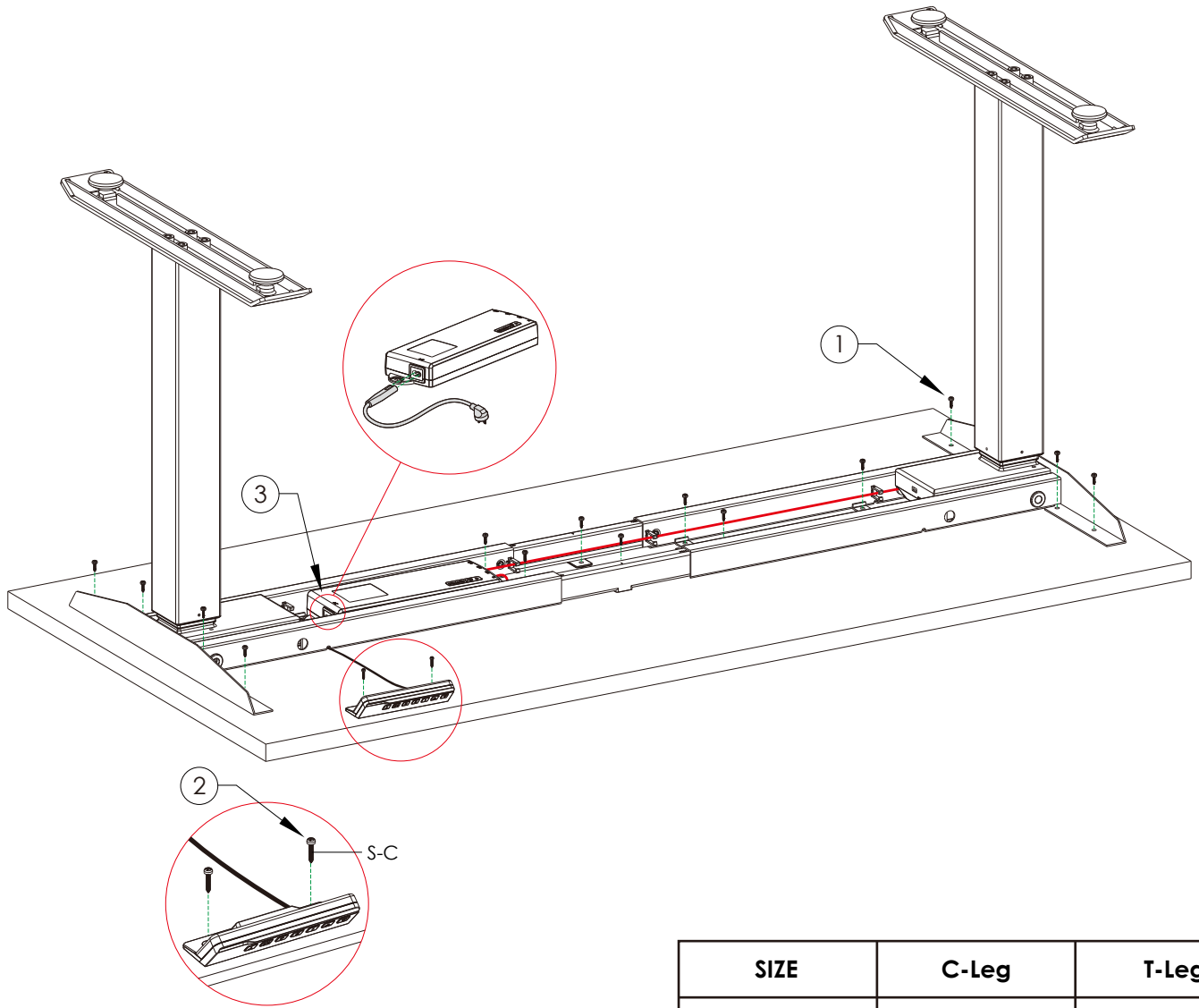

SIZE	C-Leg	T-Leg
24"	16	18
30"	24	18

1. Attach the frame assembly to the top using supplied wood screws.
2. Attach the handset to the front of the top with the two smaller wood screws provided.
3. Attach power cord. Tuck all excess cords in the frame.

To report any issues with this product, please contact our customer service department at (888) 552-5699.

# SWITCHBACK 2-LEG 3-STAGE ASSEMBLY INSTRUCTIONS

5

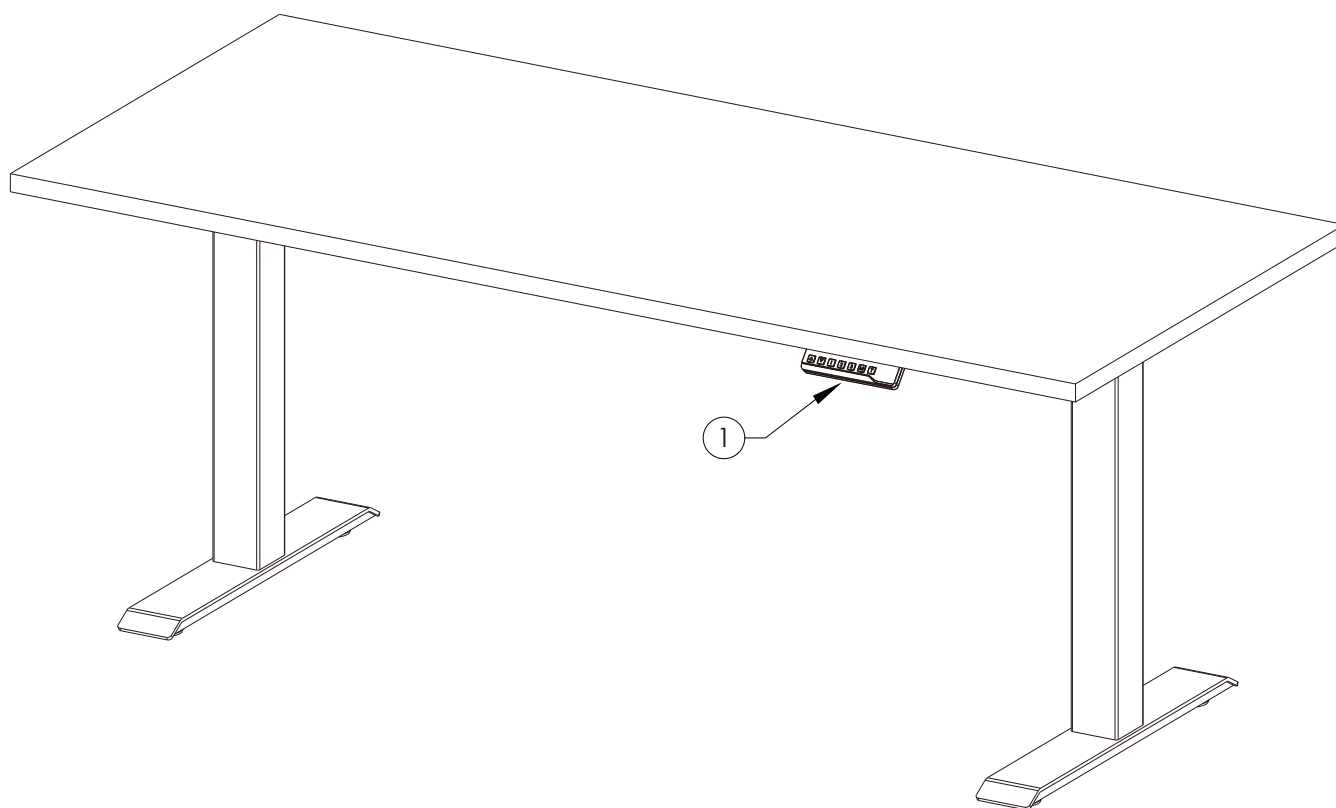

1. Flip the table to the normal position and reset it before the first use.

### Resetting the table:

Press and hold the up and down buttons at the same time for 3 seconds. Continue pressing until the columns are in the lowest position. When finished resetting, the control box will make a sound and the buttons can be released. Now the system is operational.

To report any issues with this product, please contact our customer service department at (888) 552-5699.