

VESA compatibility	75mm, 100mm
Weight capacity (Light Duty arm)	5 lbs - 20 lbs
Weight capacity (Heavy Duty arm)	10 lbs - 30 lbs
Table top thickness	0.00" - 1.62"

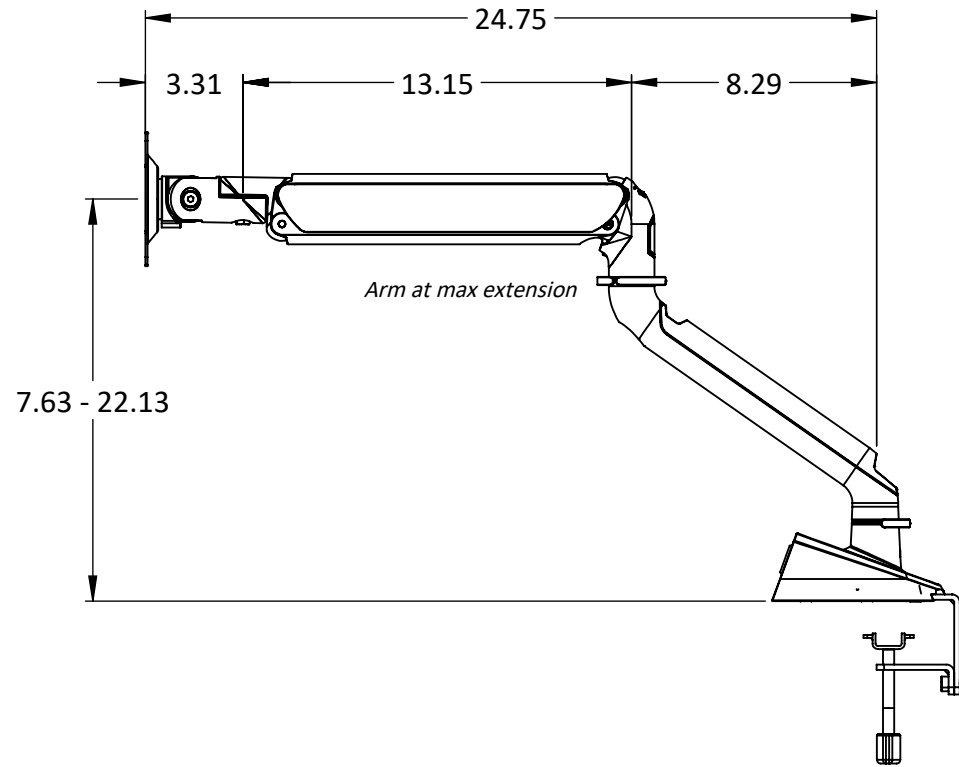
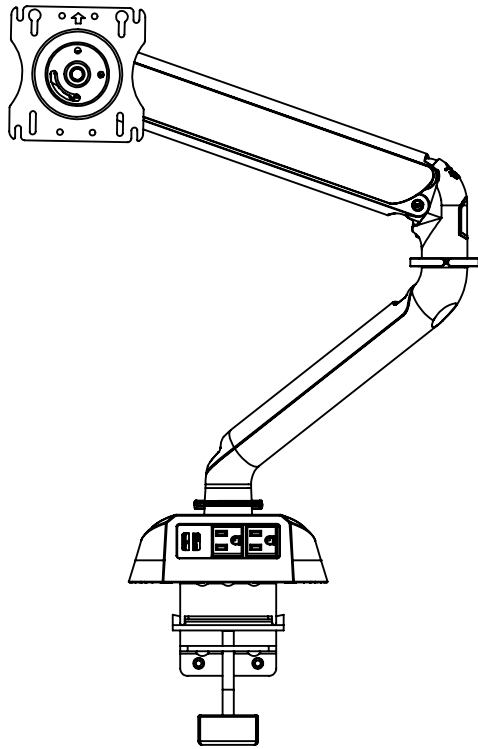

DWG TITLE

MA\_King Cobra\_Single

REV

-

DESCRIPTION

Monitor Arms, King Cobra, Single

SIZE

A

**PROPRIETARY AND CONFIDENTIAL**  
 THE INFORMATION CONTAINED IN THIS  
 DRAWING IS THE SOLE PROPERTY OF  
 SYMMETRY OFFICE. ANY REPRODUCTION  
 IN PART OR AS A WHOLE WITHOUT THE  
 WRITTEN PERMISSION OF SYMMETRY  
 OFFICE IS PROHIBITED.

2

1

VESA compatibility	75mm, 100mm
Maximum monitor size (width)	23"
Weight capacity (combined)	6 lbs - 28 lbs
Table top thickness	0.00" - 1.62"

B

B

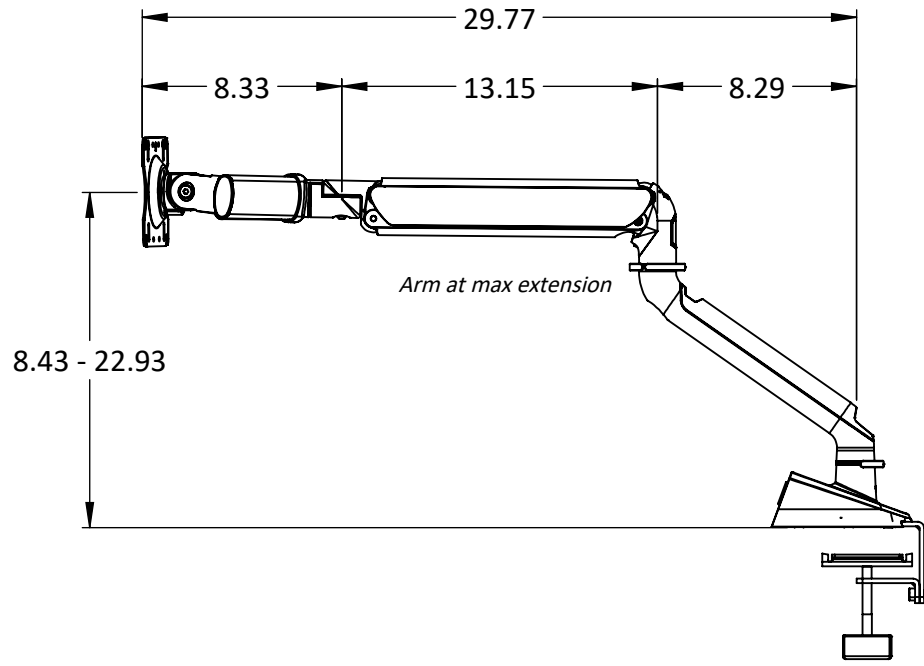
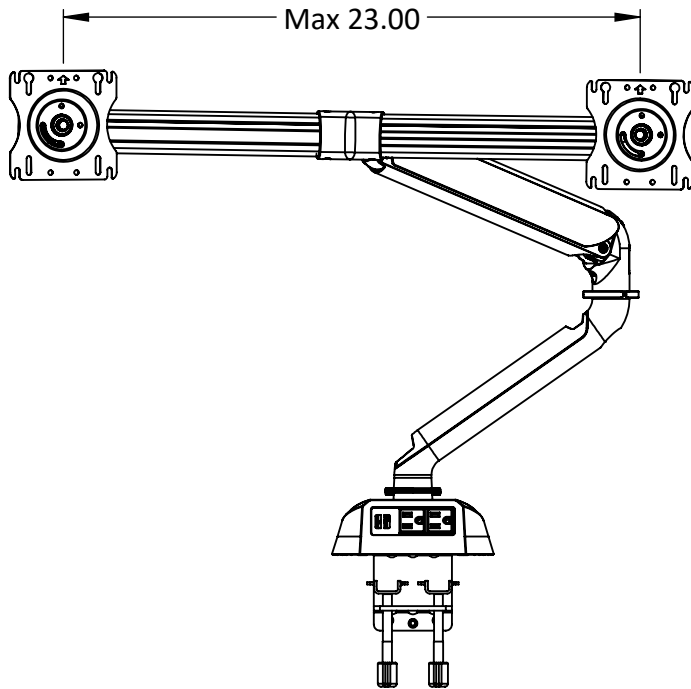

A

A



DWG TITLE	MA_King Cobra_Heavy Duty, Dual Array	REV	-
DESCRIPTION	Monitor Arms, King Cobra, Heavy Duty, Dual Array	SIZE	A

**PROPRIETARY AND CONFIDENTIAL**  
 THE INFORMATION CONTAINED IN THIS  
 DRAWING IS THE SOLE PROPERTY OF  
 SYMMETRY OFFICE. ANY REPRODUCTION  
 IN PART OR AS A WHOLE WITHOUT THE  
 WRITTEN PERMISSION OF SYMMETRY  
 OFFICE IS PROHIBITED.

2

1

2

1

VESA compatibility	75mm, 100mm
Supported monitor sizes (diagonal)	17" - 27"
Weight capacity (per monitor)	10 lbs - 30 lbs
Table top thickness	0.00" - 1.62"

B

B

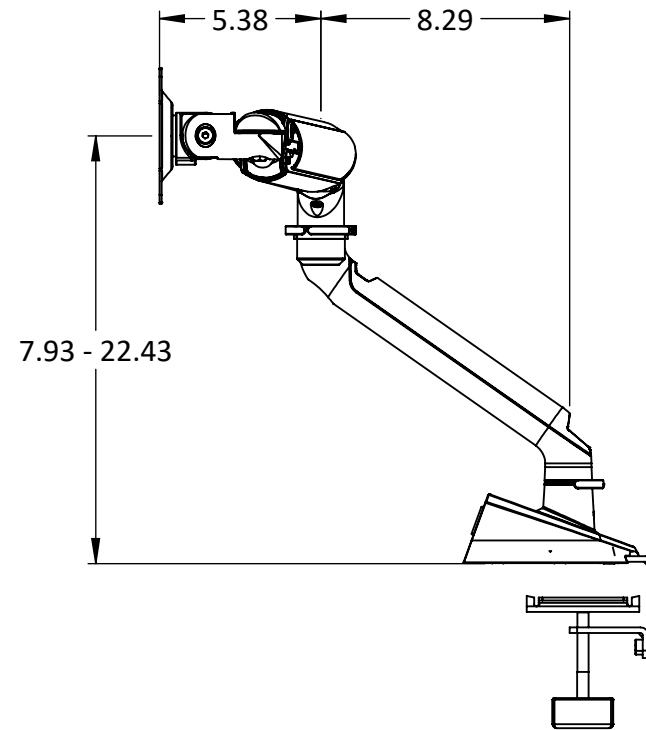
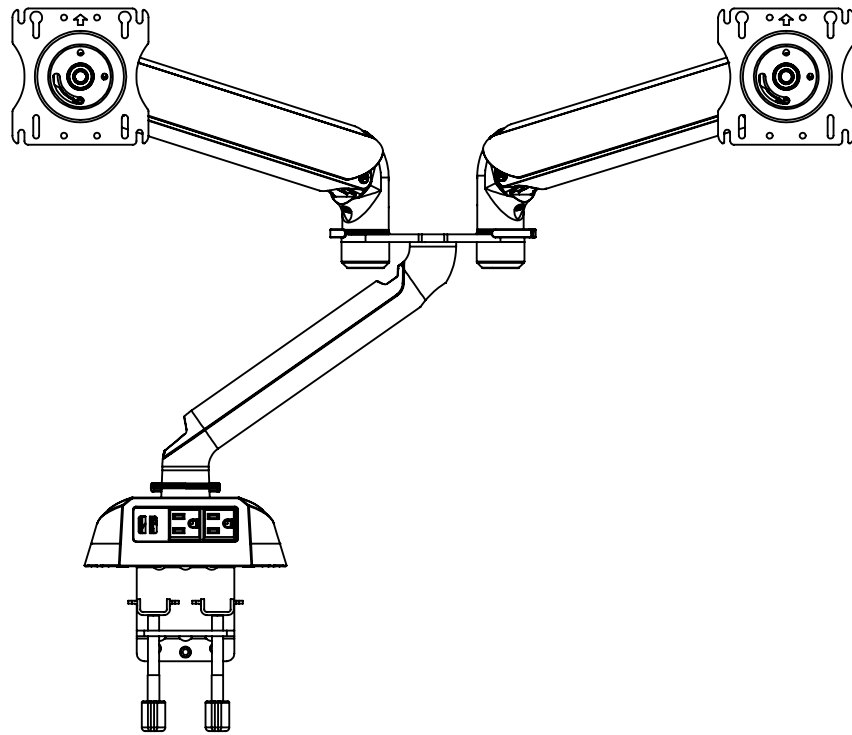

A

A



DWG TITLE	MA_King Cobra_Heavy Duty, Dual High Splitter
DESCRIPTION	Monitor Arms, King Cobra, Heavy Duty, Dual High Splitter

REV	-	<b>PROPRIETARY AND CONFIDENTIAL</b> THE INFORMATION CONTAINED IN THIS DRAWING IS THE SOLE PROPERTY OF SYMMETRY OFFICE. ANY REPRODUCTION IN PART OR AS A WHOLE WITHOUT THE WRITTEN PERMISSION OF SYMMETRY OFFICE IS PROHIBITED.
SIZE	A	

2

1

Arm at max extension