

## EVOLVE2-FF

DUAL MONITOR ARMS

Model EVOLVE2-FF-SLV  
Model EVOLVE2-FF-BLK  
Model EVOLVE2-FF-WHT

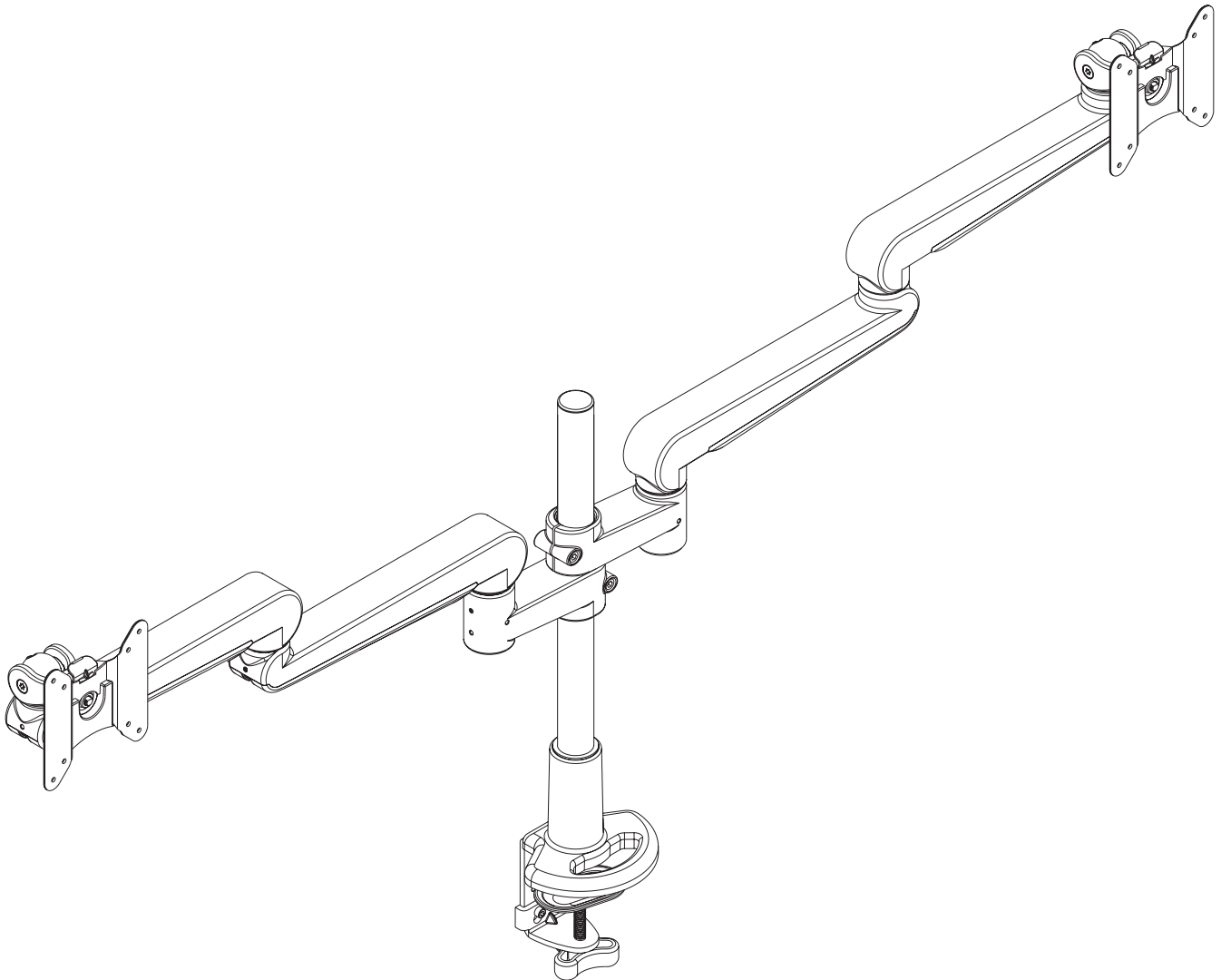









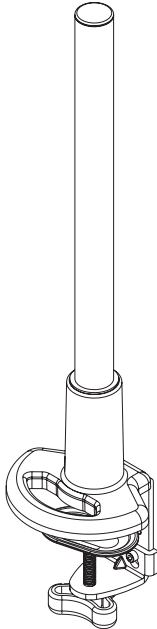
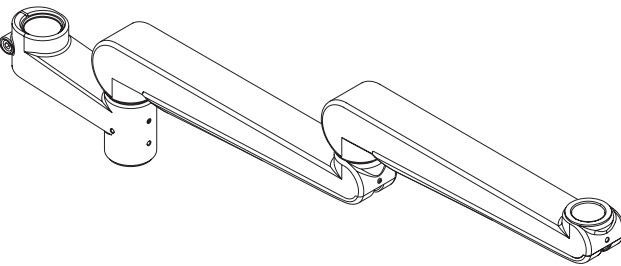
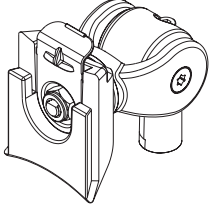
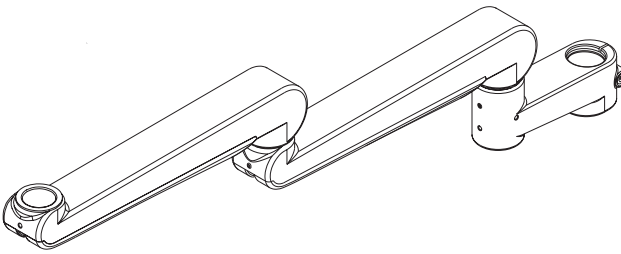
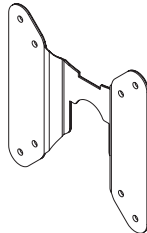

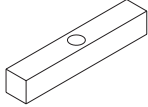
EVOLVE2-FF Rev A 2/17

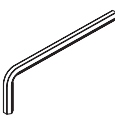
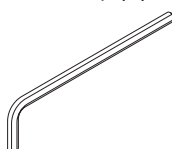

# ASSEMBLY AND ADJUSTMENT

**PLEASE REVIEW** these instructions before beginning the assembly and adjustment procedures. Check that all the parts and tools listed below were provided with your order. Contact your supplier if any materials are missing. Do not discard the packaging until satisfied that the product operates to your satisfaction.

**PARTS AND TOOLS PROVIDED**

<p>Pole Mount (1)</p> 	<p>Upper Monitor Arm Assembly (1)</p> 		<p>VESA Mount (2)</p> 
	<p>Lower Monitor Arm Assembly (1)</p> 		<p>VESA Plate (2)</p> 
<p>Clamp Pad (1)</p> 	<p>Grommet Mount Plate (1)</p> 	<p>Grommet Bar (1)</p> 	<p>Grommet Bolt (1)</p>  <p>3x<sup>3</sup>/<sub>8</sub>-16</p>
<p>Grommet Bolt Washer (1)</p>  <p>M10x27</p>	<p>Grommet Bolt Nut (2)</p>  <p>9/16x<sup>3</sup>/<sub>8</sub>-16</p>	<p>14mm Wrench (1)</p> 	<p>Pole Clip (2)</p> 
<p>2mm Allen Key (1)</p> 	<p>4mm Allen Key (1)</p> 	<p>5mm Allen Key (1)</p> 	
<p>VESA Plate Screw (4)</p>  <p>M4x10</p>	<p>VESA Locking Screw (1)</p>  <p>M4x10</p>	<p>180° Locking Screw (2)</p>  <p>M4x9</p>	<p><b>CAUTION:</b> Hand-tighten screws only. Do <b>not</b> use power tools.</p>

**ADDITIONAL TOOLS REQUIRED**

- Phillips screwdriver

**Two Base Assembly Attachment Methods**

• **Clamp method.** The base assembly is clamped to a table or desk surface that is between 0.6" (15mm) thick and 3" (76mm) thick. See below.

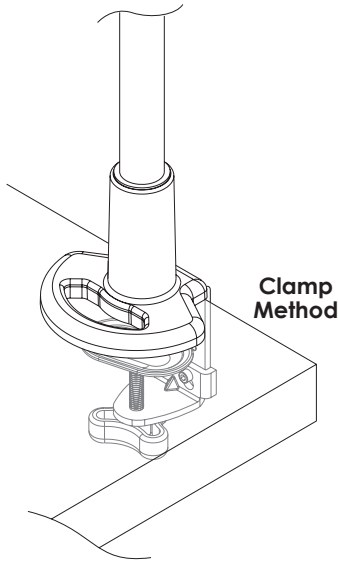

• **Grommet method.** The base assembly is secured through a grommet hole in the work surface, with a diameter between 0.78" (20mm) and 2" (51mm). Surface thickness must be between 0.6" (15mm) and 1.5" (38.1mm). See page 4.

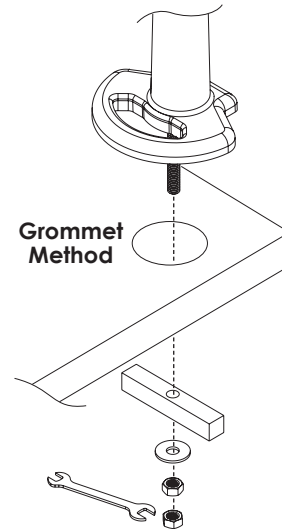

**Clamp Method**

The base assembly is shipped with the bottom clamp in the "upper attachment position." To change to the "lower attachment position" for thicker work surface, follow this procedure (see illustrations):

- Use the 4mm Allen key to remove the two screws holding the bottom clamp in position.
  - Reattach the bottom clamp to the lower two holes. Tighten the screws securely using the Allen wrench.
- CAUTION:** Do not use a power drill. Clamp screws are rated at 102 in-lbs.

**Upper Attachment Position (Standard)**

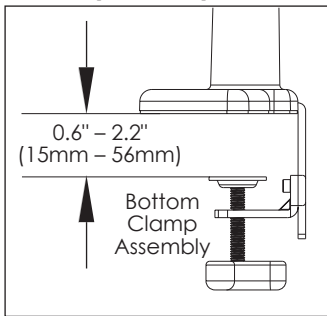

**Lower Attachment Position (Optional)**

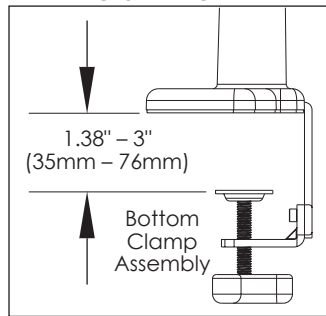

**To Change: 1) Remove Upper Attachment Screws**

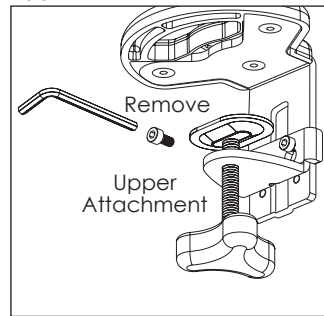

**2) Re-Install Screws with Clamp in Lower Position**

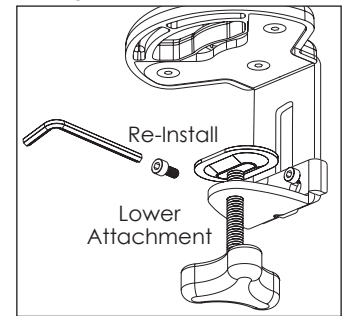

**Attach Clamp Pad**

- Peel the backing from the adhesive side of the clamp pad and adhere the pad to the bottom of the base, as shown. The pad protects the work surface.

**Install Base Assembly**

- Clamp the base assembly to the work surface. Be sure to tighten the knob securely.
- **Proceed to "Install Monitor Arm Assemblies" on page 5.**

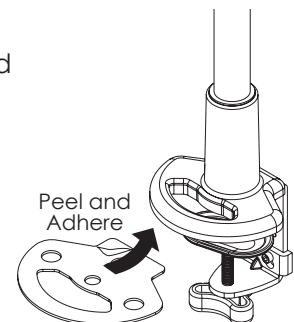

### Grommet Method

This method can be used for work surfaces that have a grommet hole in an appropriate position. Surface thickness must be between 0.6" (15mm) and 1.5" (38.1mm), and the grommet hole diameter must be between 0.78" (20mm) and 2" (51mm).

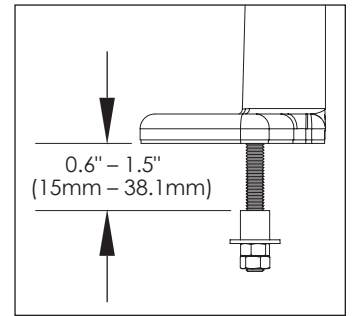

### Remove Clamp Assembly

- Remove the standard clamp assembly from the base assembly. Use the 4mm Allen key to remove the three screws holding the clamp assembly in position. Retain the three screws.

### Attach Grommet Assembly

- Place the grommet bolt in the large center hole on the grommet mount plate.
- With the grommet bolt in position, fasten the grommet mount plate and bolt to the monitor arm base with the three screws previously removed. As before, use the 4mm Allen key.

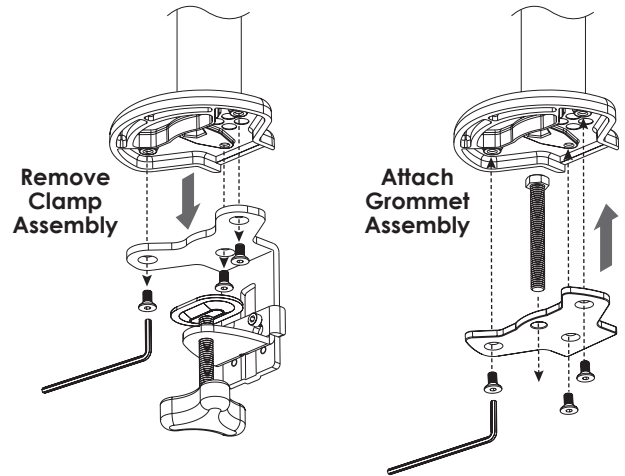

### Attach Clamp Pad

- Peel the backing from the adhesive side of the clamp pad and adhere the pad to the bottom of the grommet mount plate, as shown. The pad protects the work surface.

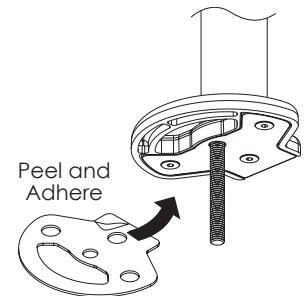

### Install Base Assembly

- Place the base assembly over the grommet hole, with the bolt centered.
- The bolt must extend under the work surface a minimum of 1.3" (33mm).
- Secure the base assembly as illustrated.
  - Secure the grommet bar and washer with one of the grommet bolt nuts. Use the provided wrench to tighten the nut securely.
  - Tighten the second nut against the first to further secure the base assembly.
- Proceed to "Install Monitor Arm Assemblies" on page 5.

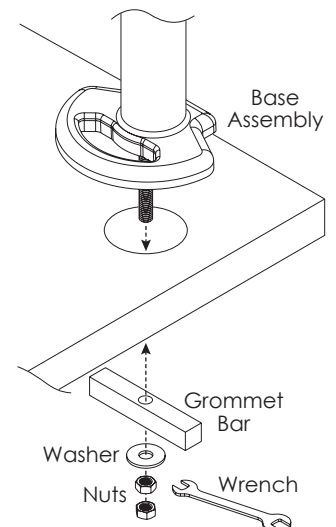

### Install Monitor Arm Assemblies

- Loosen the socket screws on the arm stems using the 5mm Allen key.
- Slide the lower monitor arm assembly onto the pole. Refer to the illustrations below to distinguish between the upper and lower arm assemblies.
  - Position the arm stem at the desired height and tighten the socket screw.
- Slide the upper monitor arm assembly onto the pole.
  - Abut the second arm stem to the first and tighten the socket screw.

**IMPORTANT:** The tops of the arm stems must align horizontally.

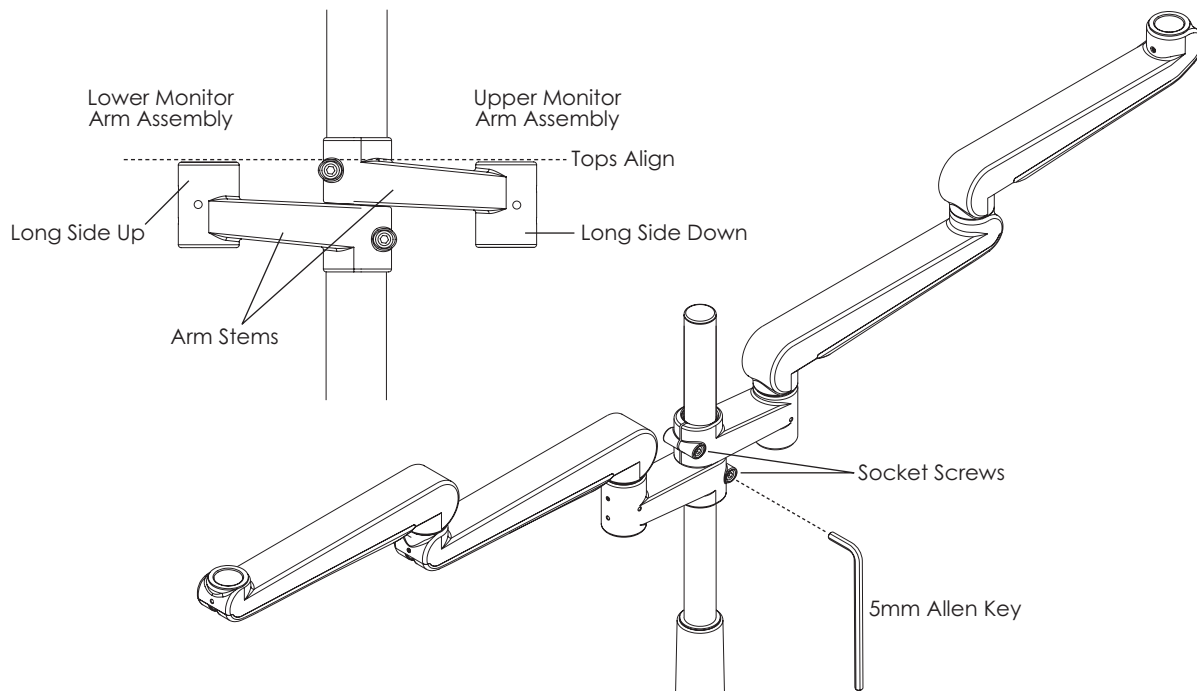

### Install VESA Mounts

- Insert the VESA mounts onto the fixed arms.
  - Align the metal plate on each VESA mount bushing with the indented groove on the fixed arms.
  - Secure the VESA mounts using the 2mm Allen key and the pre-installed set screws. Adjust the tightness to allow for the desired ease of monitor rotation.

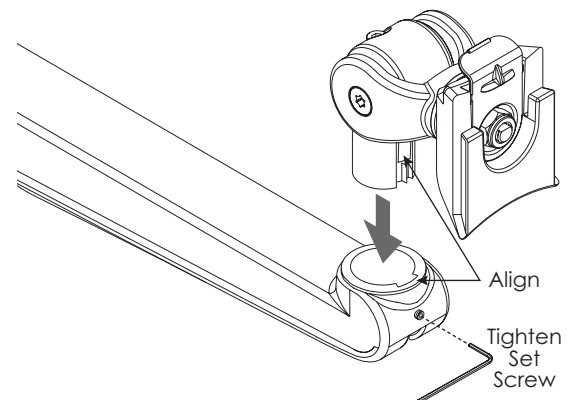

**Attach VESA Plates to Monitors**

- Place the monitors face down on a flat surface. Align the VESA plate holes with the holes on the back of the monitors. Attach the VESA plates using the eight VESA plate screws provided (four per monitor).
- There are two sets of four holes on the VESA plate. One set has holes 3.9" (100mm) apart, the other set has holes 3" (75mm) apart. Use the set that matches the holes on the monitor.

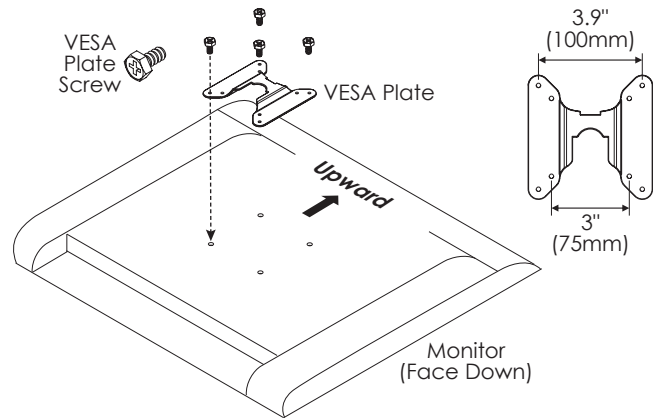

**Attach Monitors to VESA Mounts**

- Slide the VESA plates (with monitor attached) onto the VESA mounts. Make sure the VESA plate clicks securely in place.
- **Optional:** Install a VESA locking screw behind each VESA plate to prevent the tab on the VESA mount from releasing the monitor.

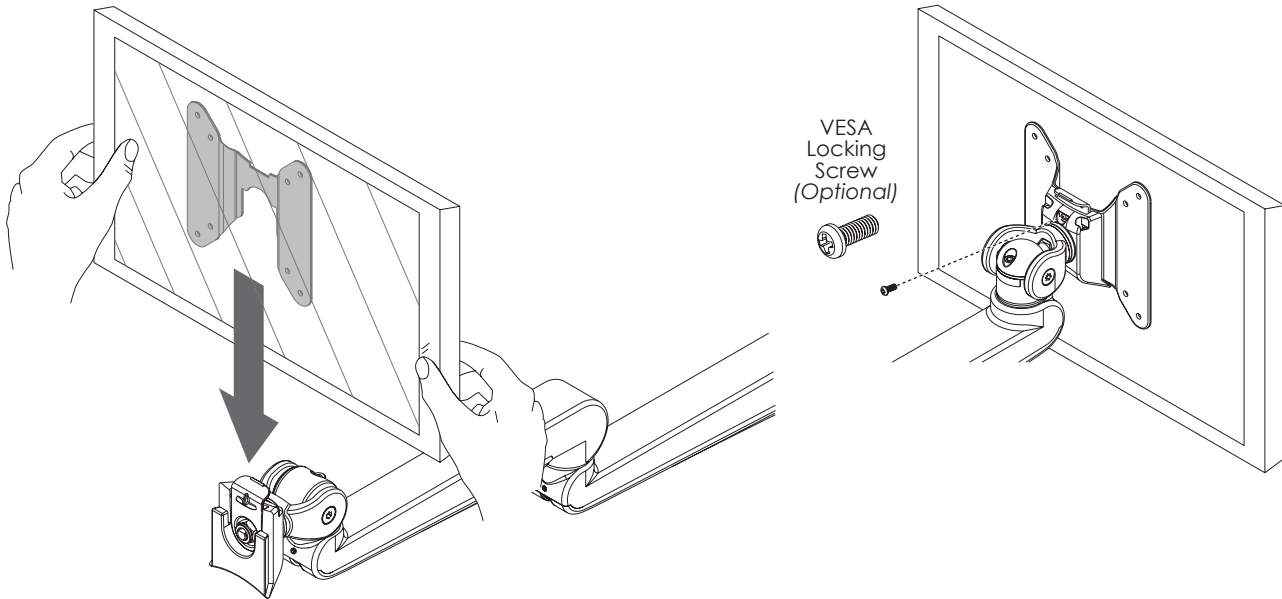

**Cable Management**

- Use the cable covers to help manage the monitor cables. Slide the cable covers out from the two fixed arms on each monitor arm assembly. Slide the cable covers back in with the cables captured.
- Use the pole clips to manage and organize the cables running down the pole. Snap the pole clips in position with the cables captured.

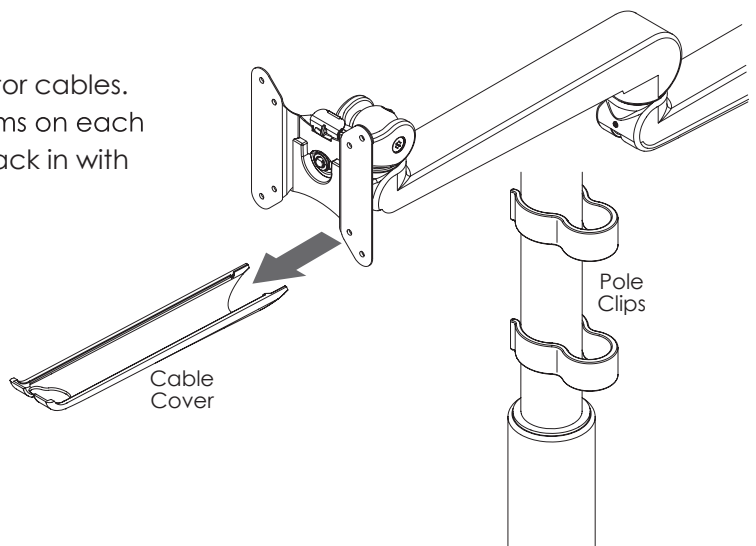

**180° Lock-Out Feature**

- Install a 180° locking screw in each of the arm stems to limit the rotation of the first fixed arm.
  - The lock-out feature allows 90° rotation toward the user, but prevents 90° rotation away from the user.
  - Install the 180° locking screw using the 2mm Allen key. Fully tighten the screw, then back it out one full turn.

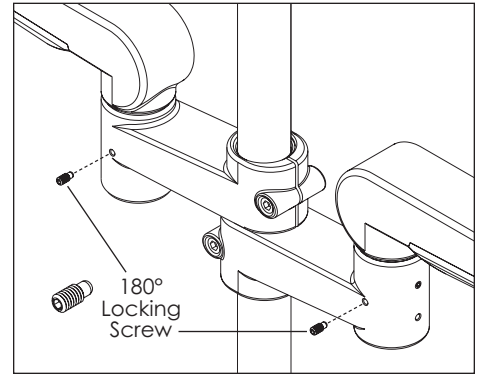

**Tension Adjustments**

The possible swivel and tilt tension adjustments for each monitor arm assembly are listed below. Refer to the illustration for the adjustment locations.

**1. Fixed arm swivel adjustments**

- Use the 2mm Allen key to adjust the set screws for the desired ease of fixed arm rotation.

**2. Monitor swivel adjustment**

- Use the 2mm Allen key to adjust the set screw for the desired ease of monitor rotation.

**3. Monitor tilt adjustment**

- Use the 4mm Allen key to adjust the set screw for the appropriate monitor weight.

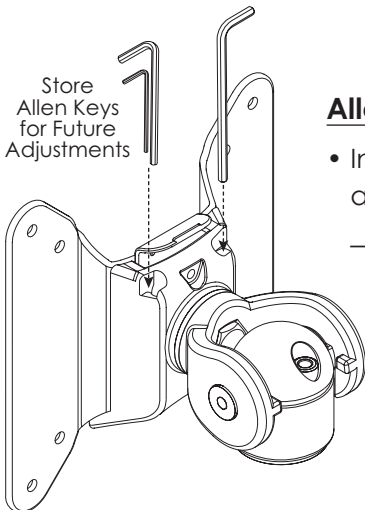
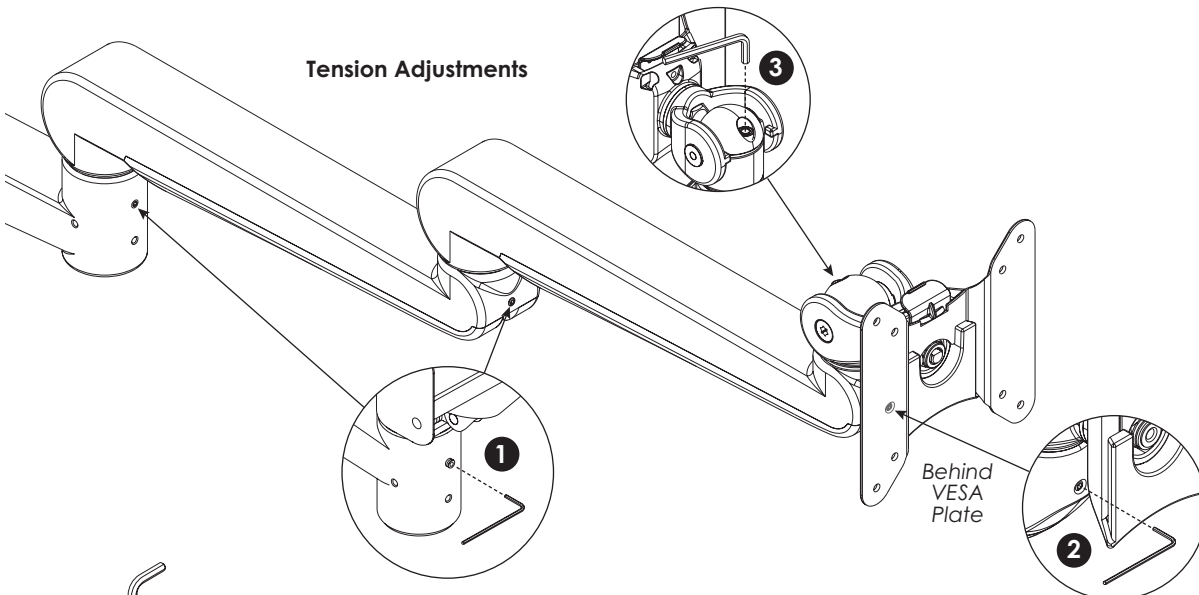

**Allen Key Storage**

- Insert the Allen keys into the holes behind the VESA plate to store for future adjustment.
  - Insert the two smaller Allen keys into the same hole.



800.833.3746 | [esiergo.com](http://esiergo.com)