

EDGE2 DUAL MONITOR ARM

Model EDGE2-SLV
Model EDGE2-BLK
Model EDGE2-WHT

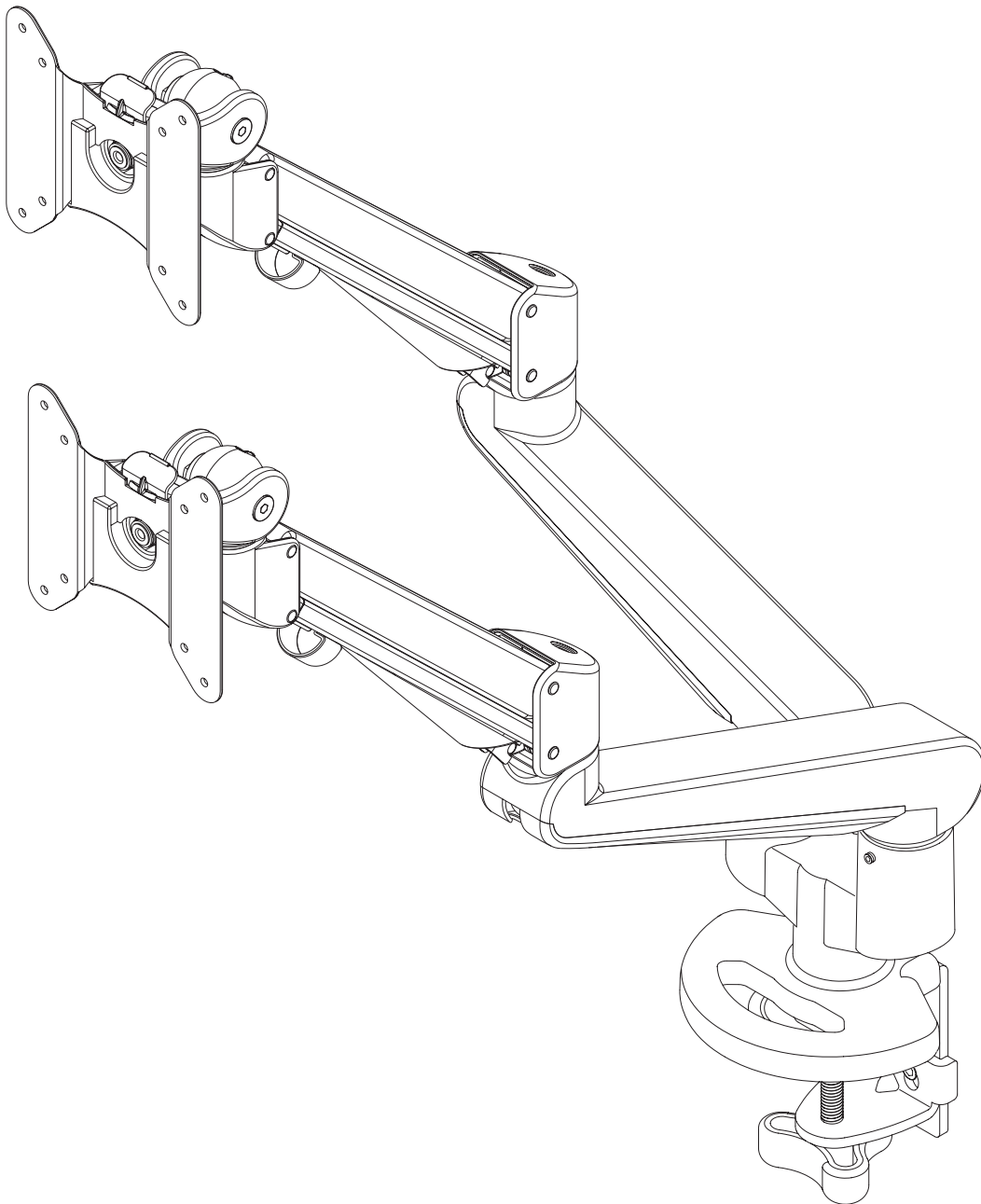







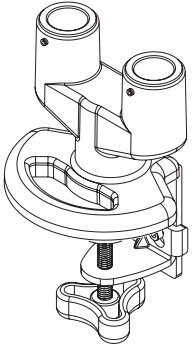
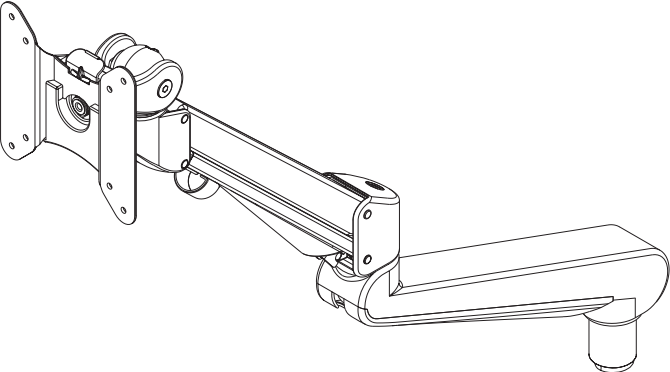

EDGE2 Rev A 2/17

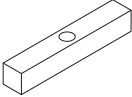
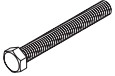

ASSEMBLY AND ADJUSTMENT

PLEASE REVIEW these instructions before beginning the assembly and adjustment procedures. Check that all the parts and tools listed below were provided with your order. Contact your supplier if any materials are missing. Do not discard the packaging until satisfied that the product operates to your satisfaction.

PARTS AND TOOLS PROVIDED

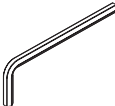
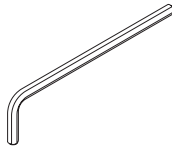
<p>Base Assembly (1)</p> 	<p>Monitor Arm Assembly (2)</p> 		
<p>Clamp Pad (1)</p> 	<p>Grommet Mount Plate (1)</p> 	<p>Grommet Bar (1)</p> 	<p>Grommet Bolt (1)</p>  <p>3x3/8-16</p>
<p>Grommet Bolt Washer (1)</p>  <p>M10x27</p>	<p>Grommet Bolt Nut (2)</p>  <p>9/16x3/8-16</p>	<p>14mm Wrench (1)</p> 	<p>CAUTION: Hand-tighten screws only. Do not use power tools.</p>
<p>VESA Plate Screw (8)</p>  <p>M4x10</p>	<p>VESA Locking Screw (2)</p>  <p>M4x10</p>	<p>180° Locking Screw (2)</p>  <p>M4x9</p>	
<p>2mm Allen Key (1)</p> 	<p>4mm Allen Key (1)</p> 	<p>5mm Allen Key (1)</p> 	

ADDITIONAL TOOLS REQUIRED

- Phillips screwdriver

Two Base Assembly Attachment Methods

• **Clamp method.** The base assembly is clamped to a table or desk surface that is between 0.6" (15mm) thick and 3" (76mm) thick. See below.

• **Grommet method.** The base assembly is secured through a grommet hole in the work surface, with a diameter between 0.78" (20mm) and 2" (51mm). Surface thickness must be between 0.6" (15mm) and 1.5" (38.1mm). See page 4.

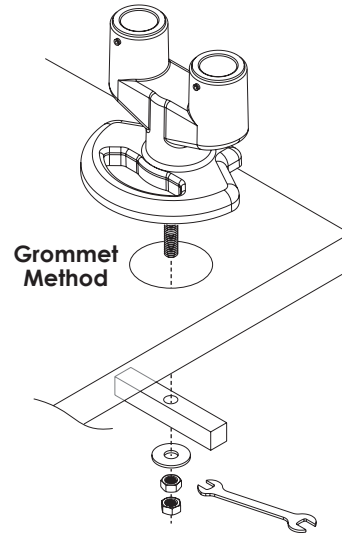
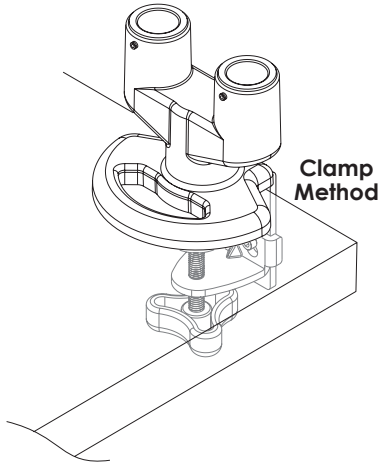

Clamp Method

The base assembly is shipped with the bottom clamp in the "upper attachment position." To change to the "lower attachment position" for thicker work surface, follow this procedure (see illustrations):

- Use the 4mm Allen key to remove the two screws holding the bottom clamp in position.
- Reattach the bottom clamp to the lower two holes. Tighten the screws securely using the Allen wrench.

CAUTION: Do not use a power drill. Clamp screws are rated at 102 in-lbs.

Upper Attachment Position (Standard)

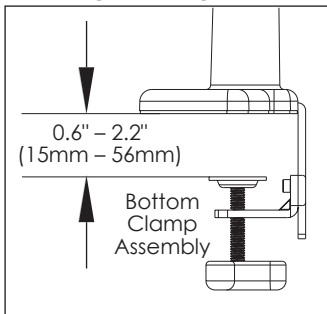

Lower Attachment Position (Optional)

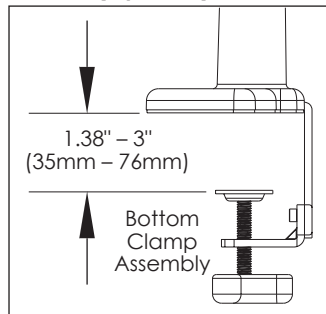

To Change: 1) Remove Upper Attachment Screws

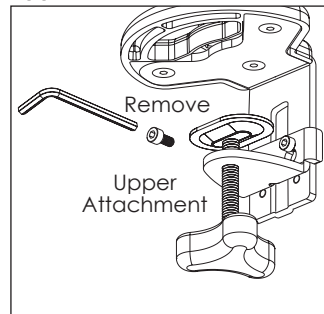

2) Re-Install Screws with Clamp in Lower Position

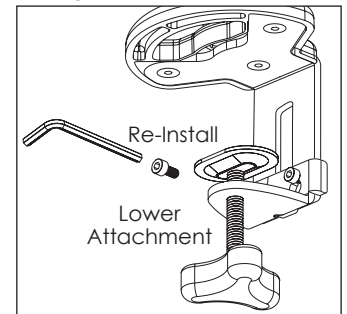

Attach Clamp Pad

- Peel the backing from the adhesive side of the clamp pad and adhere the pad to the bottom of the base, as shown. The pad protects the work surface.

Install Base Assembly

- Clamp the base assembly to the work surface. Be sure to tighten the knob securely.
- **Proceed to "Install Monitor Arm Assemblies" on page 5.**

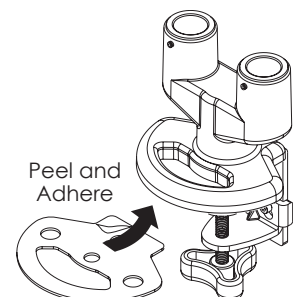

Grommet Method

This method can be used for work surfaces that have a grommet hole in an appropriate position. Surface thickness must be between 0.6" (15mm) and 1.5" (38.1mm), and the grommet hole diameter must be between 0.78" (20mm) and 2" (51mm).

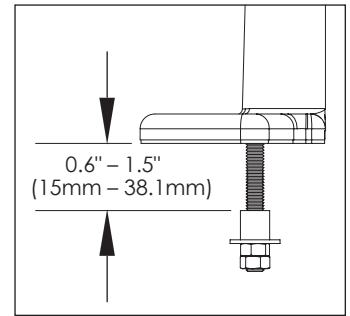

Remove Clamp Assembly

- Remove the standard clamp assembly from the base assembly. Use the 4mm Allen key to remove the three screws holding the clamp assembly in position. Retain the three screws.

Attach Grommet Assembly

- Place the grommet bolt in the large center hole on the grommet mount plate.
- With the grommet bolt in position, fasten the grommet mount plate and bolt to the monitor arm base with the three screws previously removed. As before, use the 4mm Allen key.

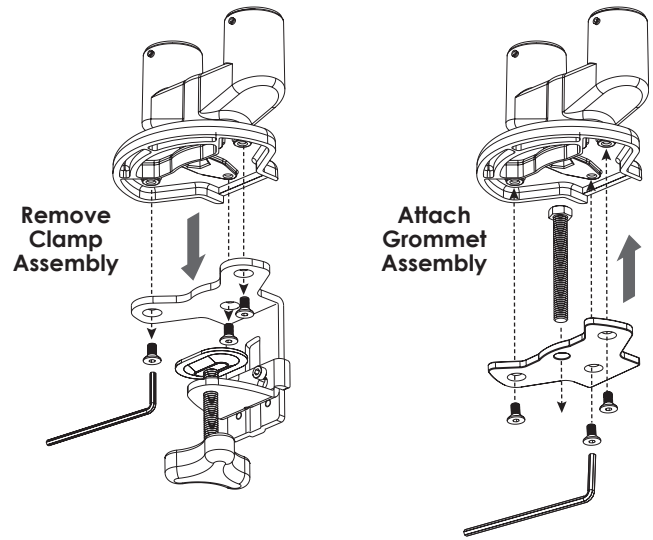

Attach Clamp Pad

- Peel the backing from the adhesive side of the clamp pad and adhere the pad to the bottom of the grommet mount plate, as shown. The pad protects the work surface.

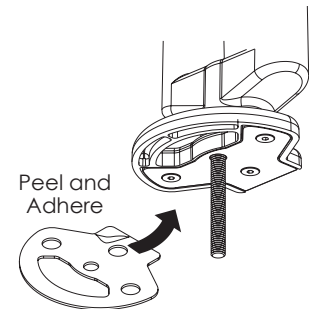

Install Base Assembly

- Place the base assembly over the grommet hole, with the bolt centered.
- The bolt must extend under the work surface a minimum of 1.3" (33mm).
- Secure the base assembly as illustrated.
 - Secure the grommet bar and washer with one of the grommet bolt nuts. Use the provided wrench to tighten the nut securely.
 - Tighten the second nut against the first to further secure the base assembly.
- Proceed to "Install Monitor Arm Assemblies" on page 5.

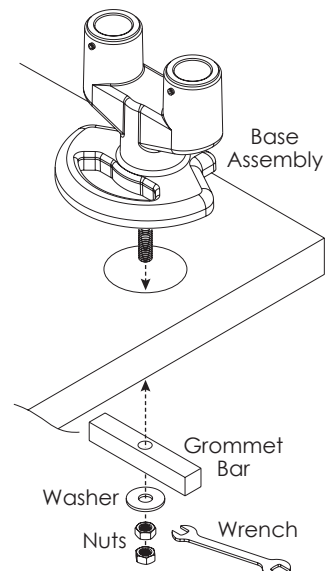

Install Monitor Arm Assemblies

- Insert the monitor arms into the base assembly.
- Secure each monitor arm by tightening the set screws using the 2mm Allen key. Adjust the tightness to allow for the desired ease of monitor arm rotation.

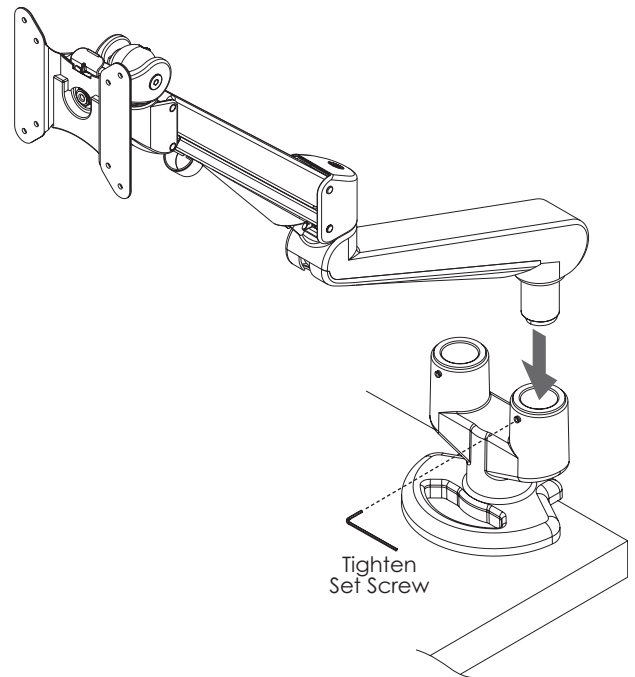

Install Monitors

- Remove the VESA plate from each VESA mount by pressing down on the plastic tab to release the lock. Pull the plate upward to remove.

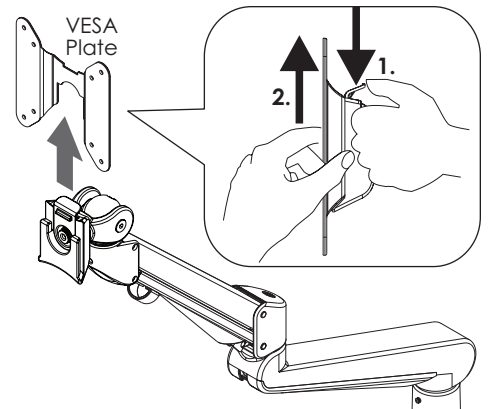

- Place each of the LCD monitors face down on a flat surface. Align the VESA plate holes with the holes on the back of the monitor. Attach the VESA plates using the eight VESA plate screws provided (four screws per monitor).
 - There are two sets of four holes on each VESA plate. One set has holes 3.9" (100mm) apart, the other set has holes 3" (75mm) apart. Use the set that matches the holes on the monitor.

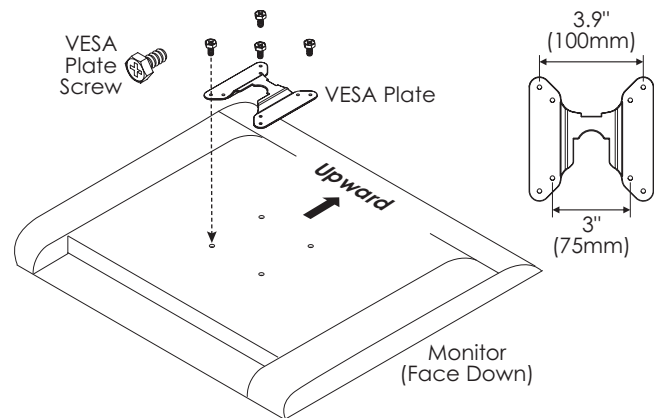

- Slide each VESA plate (with monitor attached) back onto the VESA mount. Make sure the VESA plate clicks securely in place.
- **Optional:** Install a VESA locking screw behind each VESA plate to prevent the tab on the VESA plate from releasing the monitors. Tilt the monitor down for easier access to the screw hole.

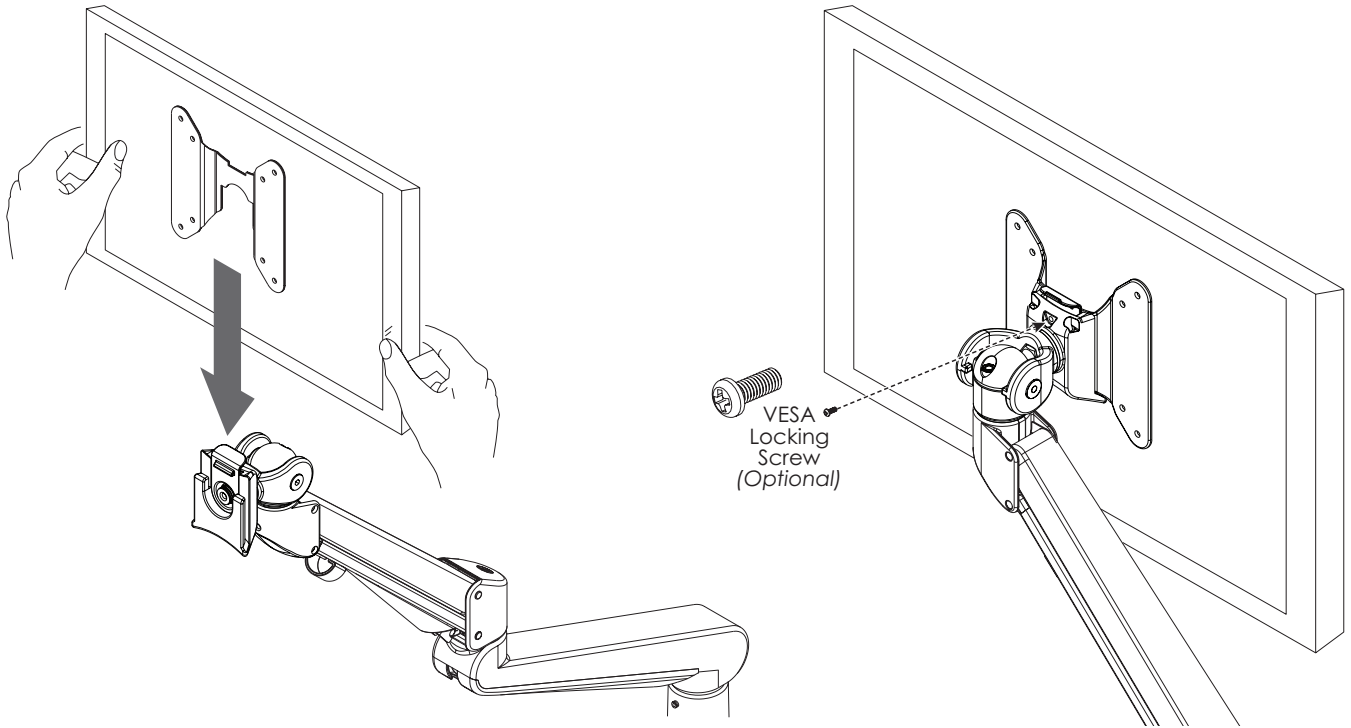

Cable Management

Use the cable clip and cable cover to help manage the monitor cables.

- Pinch the cable clip to remove it from the motion arm, and again when re-installing it with the cables captured.
- Slide the cable cover out from the fixed arm. Slide it back in with the cables captured.

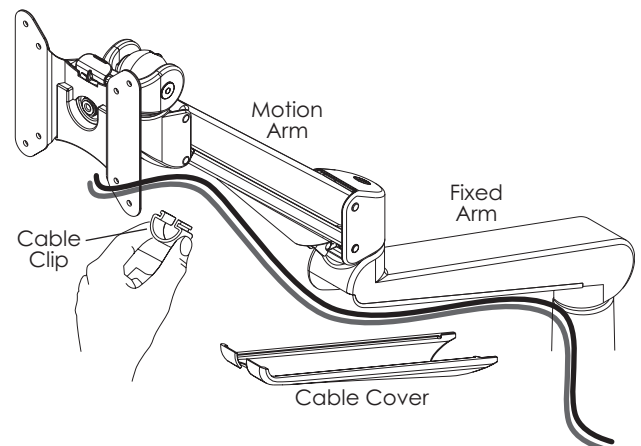

180° Lock-Out Feature

- Use the 2mm Allen key to secure the 180° locking screws into the base of each monitor arm assembly to limit the fixed monitor arm rotation to 180°. Fully tighten the screws, then back out one full turn.

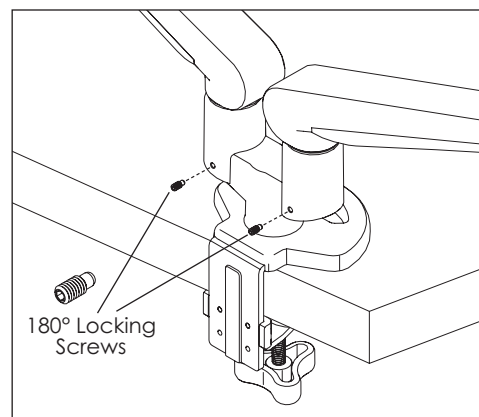

Tension Adjustments

There are five possible swivel and tilt tension adjustments for each of the two monitor arms:

1. Monitor swivel adjustment

— Use the 2mm Allen key to adjust the set screw for the desired ease of monitor rotation.

2. Motion arm swivel adjustment

— Use the 2mm Allen key to adjust the set screw for the desired ease of motion arm rotation.

3. Fixed arm swivel adjustment

— Use the 2mm Allen key to adjust the set screw for the desired ease of fixed arm rotation.

4. Monitor tilt adjustment

— Use the 4mm Allen key to adjust the set screw for the appropriate monitor weight.

5. Monitor arm weight adjustment

— Use the 5mm Allen key to adjust the set screw for the appropriate monitor weight.

— Weight capacity per arm is 6.5 lbs to 17.6 lbs (2.9 kg to 7.98 kg). Capacity may be reduced if monitor size is greater than 26" (66cm) or depth is greater than 2.17" (55mm).

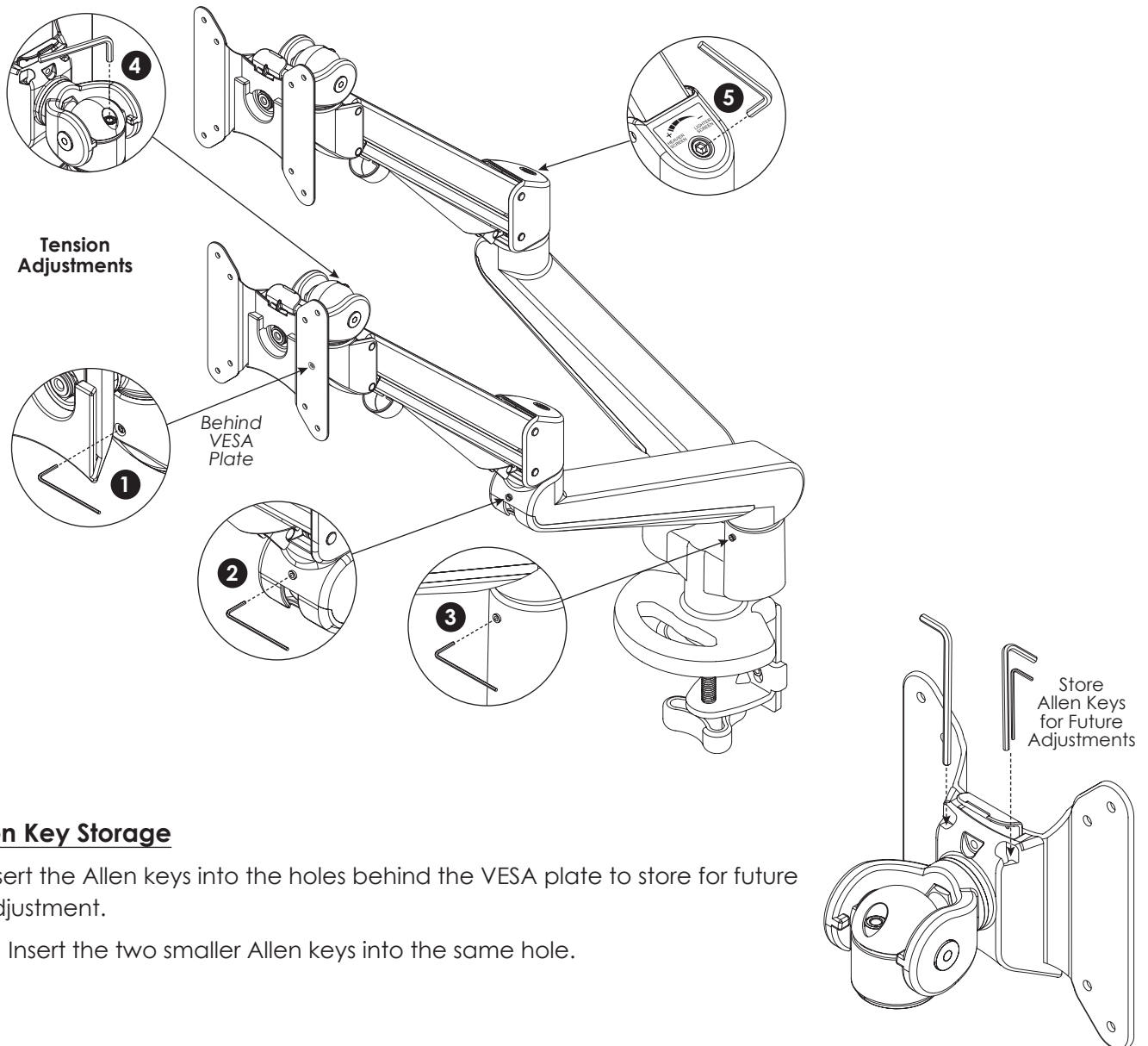

Allen Key Storage

- Insert the Allen keys into the holes behind the VESA plate to store for future adjustment.
 - Insert the two smaller Allen keys into the same hole.



800.833.3746 | esiergo.com