

USB AC MODUAL = U

USE SC\_CMS129\_08  
WHEN INSTALLING USB

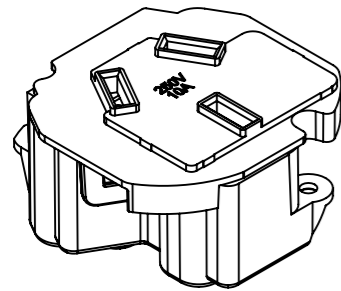
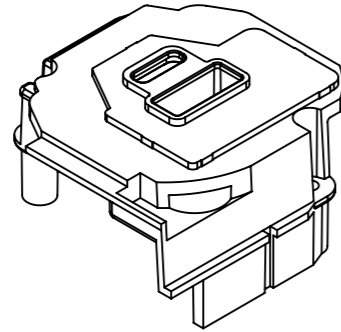

AU/NZ SOCKET OUTLET = A

**FACTORY ONLY INSERTABLE MODULES  
REFER PAGE 2 FOR MODULE  
CONFIGURATION**

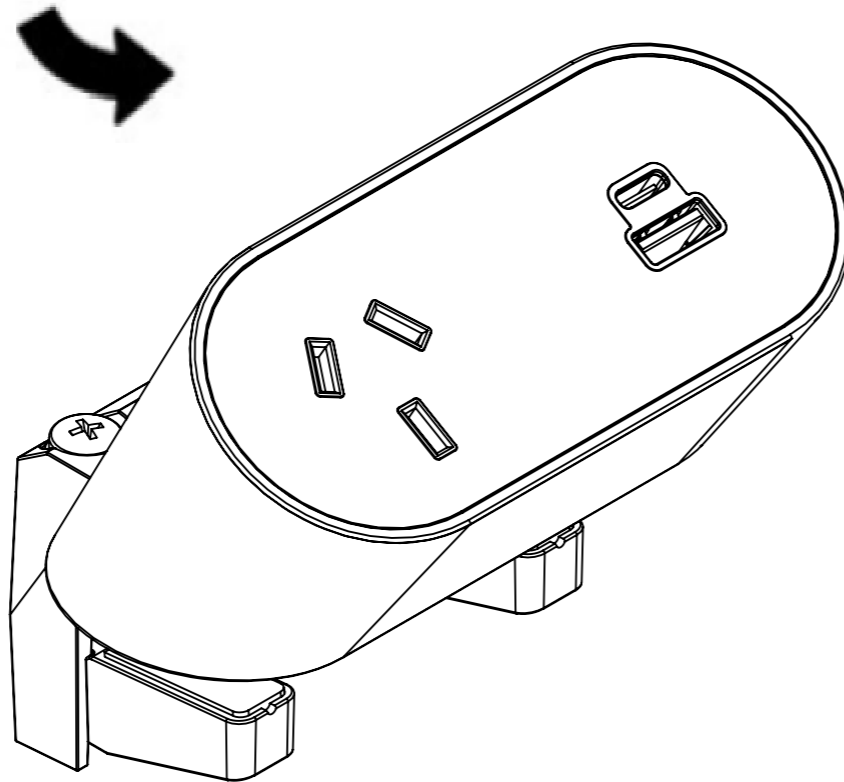

**ABOVE DESK CLAMP**

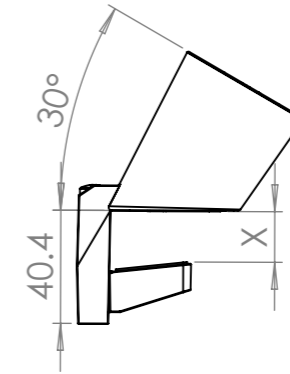

MIN TABLE THICKNESS: 20MM  
MAX TABLE THICKNESS 32MM

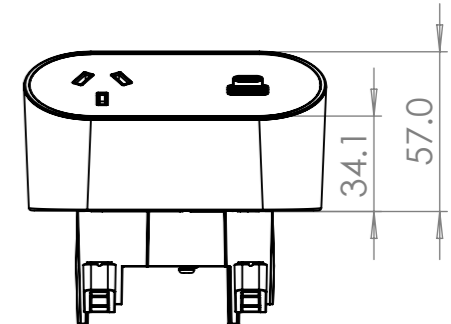
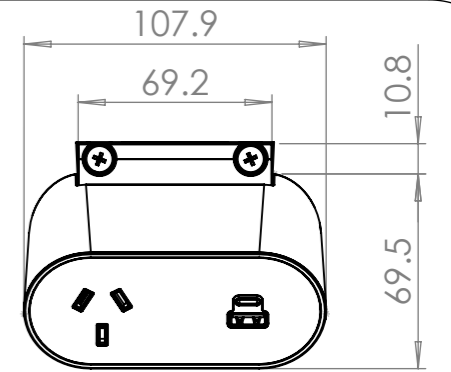

**UNDER DESK CLAMP**

COMPATIBLE MOUNTING  
SCREWS: 4G, 6G

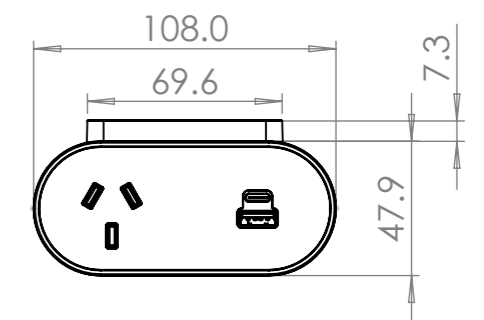
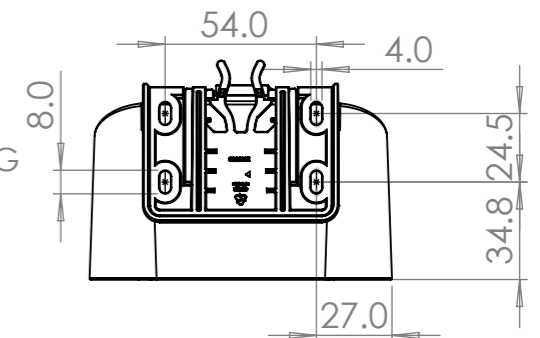
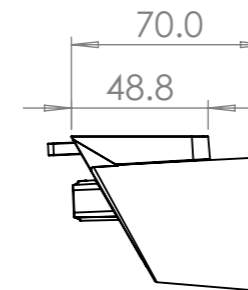

REV	DESCRIPTION	DATE	DRWN	APPV
4	BOM UPDATED, WIRING LOOM LU's UPDATED	5/4/2022	JB	RG
3	ITEM 10 IN BOM UPDATED TO 4G x 3/8' PAN HEAD SELF TAPPING SCREW TYPE B	10/2/2022	JB	RG
2	BOM UPDATED	19/5/2021	JB	RG
1	RELEASED FOR EVALUATION	7/5/2021	JB	RG
REVISIONS				

<b>CUSTOMER SIGNATURE:</b>
<b>MATERIAL:</b> PC FR
<b>FINISH:</b> FINE EDM / POLISHED / FABRIC
<b>COLOUR:</b> REFER TABLE
THIS DRAWING & ASSOCIATED CAD FILES ARE ISSUED IN THE STRICTEST CONFIDENCE AND ARE ONLY TO BE USED IN THE COMMERCIAL INTERESTS OF CMS ELECTRACOM PTY LTD

**TOLERANCES UNLESS OTHERWISE STATED:**

X ±0.5  
X.X ±0.2  
X.XX ±0.1  
X.XXX ±0.05  
ANG ±0.5°

DRAWN IN mm TO AS1100 DO NOT SCALE



**TITLE:**  
NOVA DUO AU CONFIGURATIONS

<b>DRAWING:</b> LU38121	<b>REV:</b> 4	<b>A3</b>
SCALE 1:2	SHEET 1 OF 6	

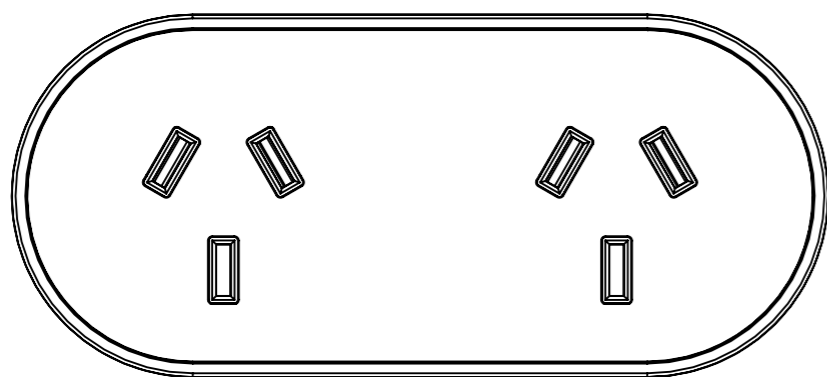

ND\*AAXxxXX

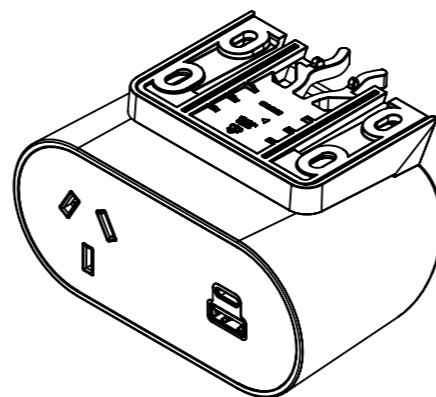

Z = UNDER DESK CLAMP

COLOUR VARIATIONS	
PART NUMBER	DESCRIPTION
W	WHITE BODY & CLAMP
B	BLACK BODY & CLAMP
1	WHITE DECAL GLOSS
2	WHITE DECAL MATT
3	BLACK DECAL GLOSS
4	BLACK DECAL MATT
FABRIC FINISH REFER TO LU38547	
A	FABRIC COLOUR 1
B	FABRIC COLOUR 2
C	FABRIC COLOUR 3
D	FABRIC COLOUR 4

NOTE:

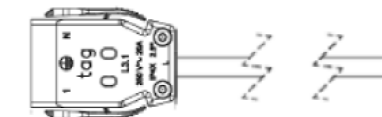

CABLE TYPE: 3 CORE x 2.5mm<sup>2</sup>  
 DESCRIPTION: TAG CONNECTOR LEAD  
 COLOUR: WHITE OR BLACK  
 (REFER TO PURCHASE ORDER)  
 LENGTH (mm):

xx	LENGTH (mm)
05	500
10	1000
15	1500
20	2000
25	2500
30	3000
35	3500
40	4000
45	4500
50	5000

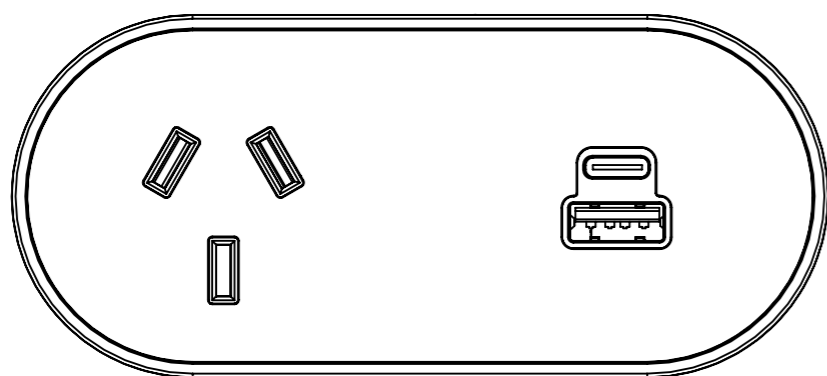

ND\*AUXxxXX

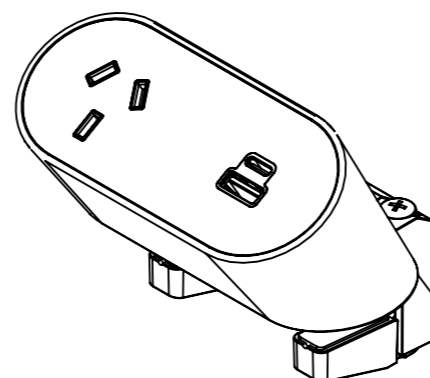

S= ABOVE DESK CLAMP

NOTE:

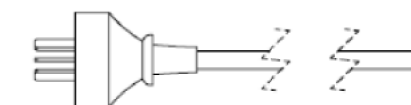

CABLE TYPE: 3 CORE x 1.0mm<sup>2</sup>  
 DESCRIPTION: AUSTRALIAN PLUG LEAD  
 COLOUR: WHITE OR BLACK  
 (REFER TO PURCHASE ORDER)  
 LENGTH (mm):

xx	LENGTH (mm)
05	500
10	1000
15	1500
20	2000
25	2500
30	3000
35	3500
40	4000
45	4500
50	5000

**PART NUMBER:** (REFER CONFIGURATION)xxXX

NOTE - \* - CLAMP TYPE - (S = ABOVE DESK OR Z = UNDER DESK)

X - LEAD TYPE (TAG = T OR 3PIN PLUG = I)

xx - LENGTH - 05 / 10 / 15 / 20 / 25 / 30 / 35 / 40 / 45 / 50

XX - COLOUR - W / B + 1 / 2 / 3 / 4 + (OPTIONAL) A / B / C / D

<b>CUSTOMER SIGNATURE:</b>	<b>TOLERANCES UNLESS OTHERWISE STATED:</b>  X ±0.5 X.X ±0.2 X.XX ±0.1 X.XXX ±0.05 ANG ±0.5°	 <b>CMS Electracom</b> COPYRIGHT © 2020		
<b>MATERIAL:</b> PC FR				<b>TITLE:</b> NOVA DUO AU CONFIGURATIONS
<b>FINISH:</b> FINE EDM / POLISHED / FABRIC		<b>DRAWING:</b> LU38121	<b>REV:</b> 4	A3
<b>COLOUR:</b> REFER TABLE		SCALE 1:2		
THIS DRAWING & ASSOCIATED CAD FILES ARE ISSUED IN THE STRICTEST CONFIDENCE AND ARE ONLY TO BE USED IN THE COMMERCIAL INTERESTS OF CMS ELECTRACOM PTY LTD		DRAWN IN mm TO AS1100 DO NOT SCALE		

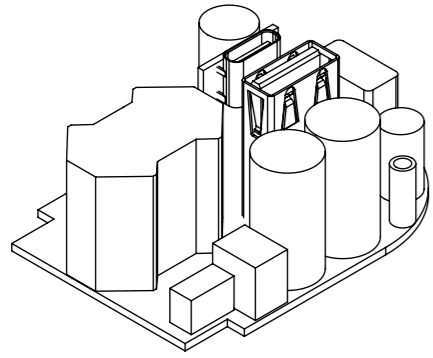

30W USB AC MODUAL = U

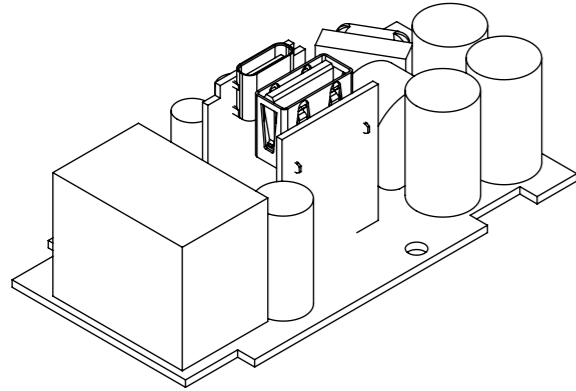

65W USB AC MODUAL = W

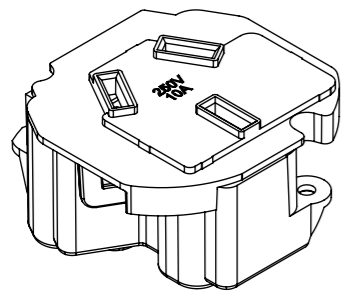

AU/NZ SOCKET OUTLET = A

USE SC\_CMS129\_08  
WHEN INSTALLING USB

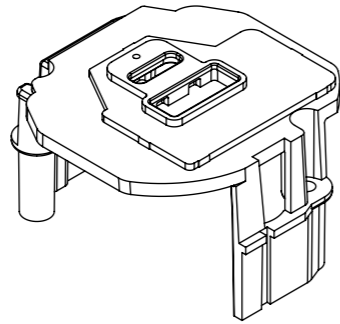

FACTORY ONLY INSERTABLE MODULES  
REFER PAGE 2 FOR MODULE  
CONFIGURATION

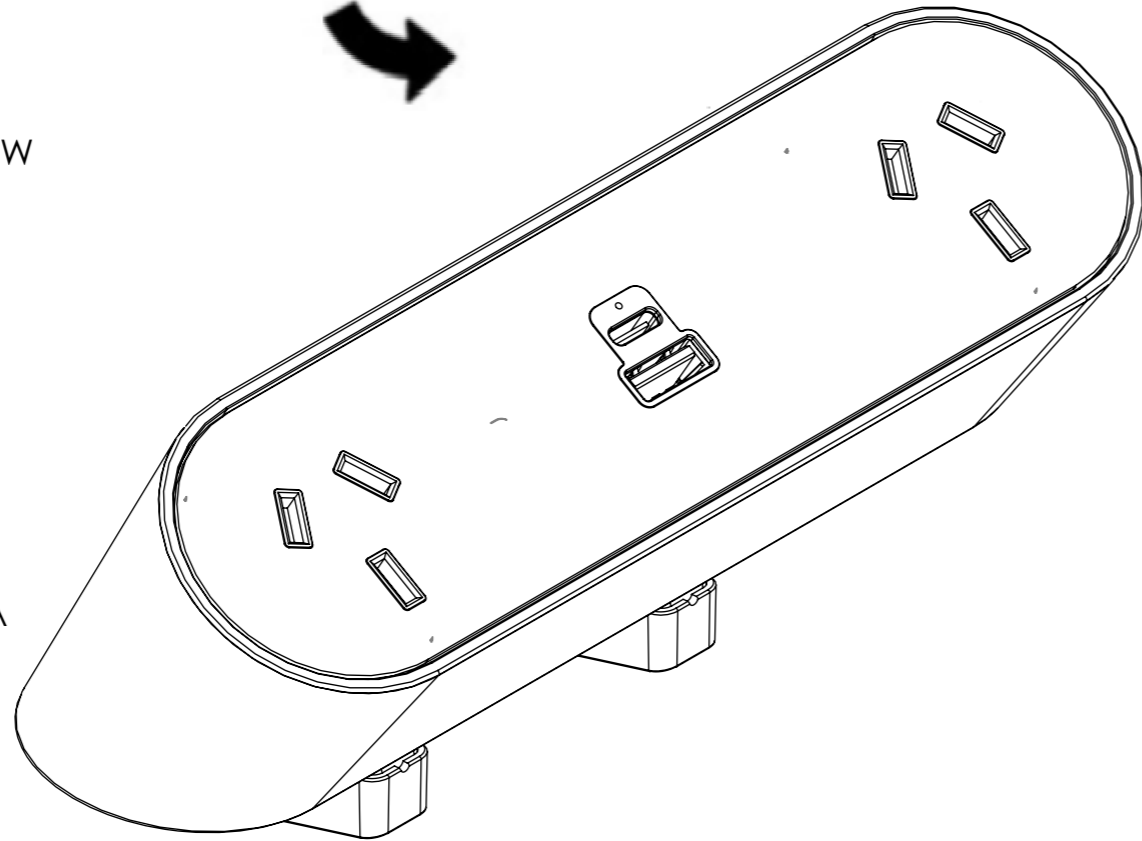

ABOVE DESK CLAMP

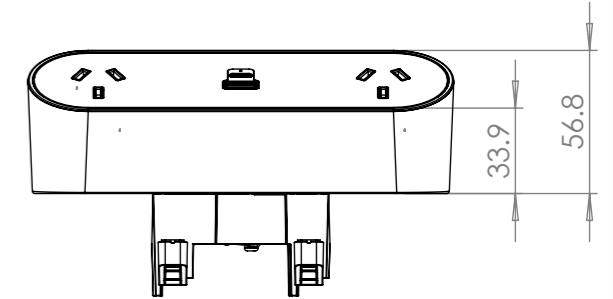
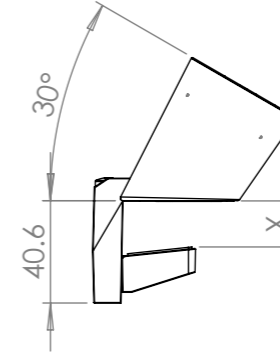
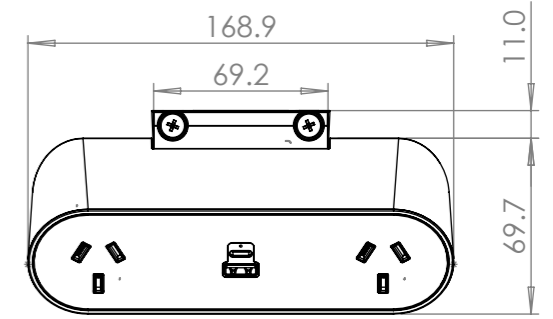

MIN TABLE THICKNESS: 20MM  
MAX TABLE THICKNESS: 32MM

UNDER DESK CLAMP

COMPATIBLE MOUNTING  
SCREWS: 4G, 6G

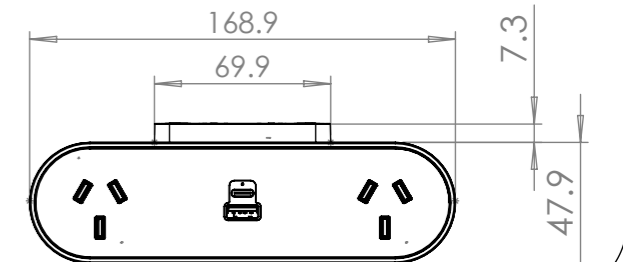
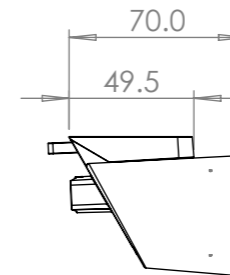
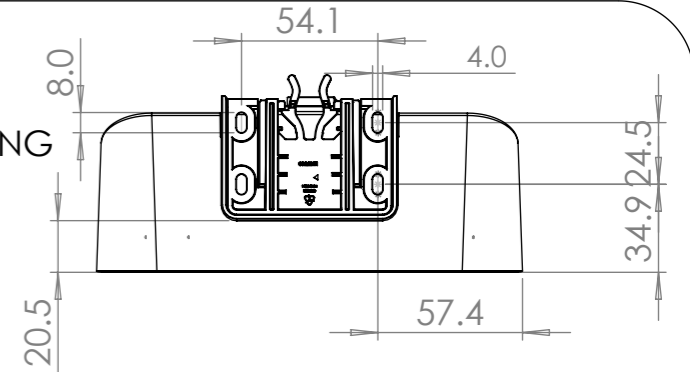

CUSTOMER  
SIGNATURE:

MATERIAL: PC FR

FINISH: FINE EDM / POLISHED /  
FABRIC

COLOUR: REFER TABLE

TOLERANCES UNLESS  
OTHERWISE STATED:

X ±0.5  
X.X ±0.2  
X.XX ±0.1  
X.XXX ±0.05  
ANG ±0.5°



**CMS Electracom** COPYRIGHT  
© 2020

TITLE:  
NOVA TRIO AU CONFIGURATIONS

DRAWING:  
LU39296

REV:  
1 A3

THIS DRAWING & ASSOCIATED CAD FILES ARE  
ISSUED IN THE STRICTEST CONFIDENCE AND  
ARE ONLY TO BE USED IN THE COMMERCIAL  
INTERESTS OF CMS ELECTRACOM PTY LTD

DRAWN IN mm  
TO AS1100  
DO NOT SCALE

SCALE 1:2

SHEET 1 OF 4

1	RELEASED FOR PRODUCTION	8/4/2022	JB	RG
REV	DESCRIPTION	DATE	DRWN	APPV
REVISIONS				

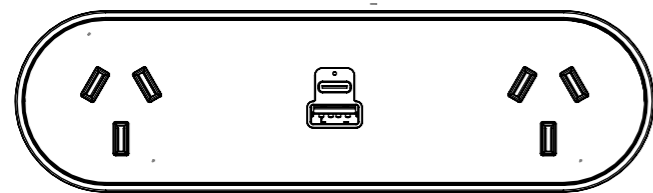

NT\*AUAXxxXX

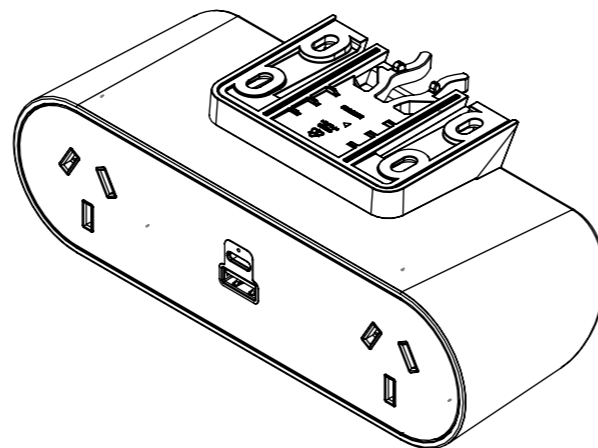

Z = UNDER DESK CLAMP

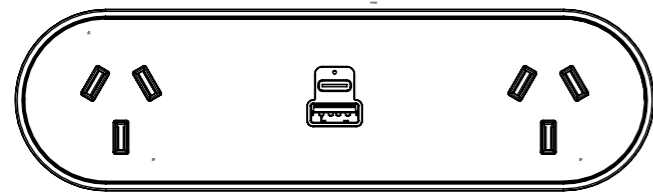

NT\*AWAXxxXX

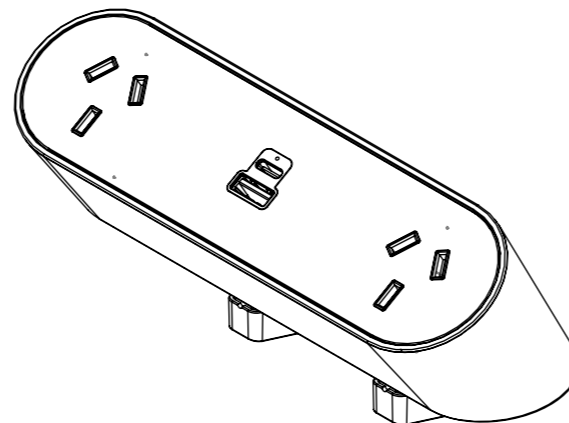

S = ABOVE DESK CLAMP

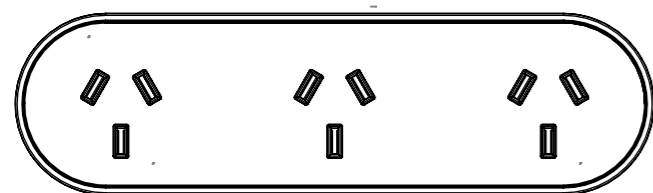

NT\*AAAXxxX

COLOUR VARIATIONS	
PART NUMBER	DESCRIPTION
W	WHITE BODY & CLAMP
B	BLACK BODY & CLAMP
1	WHITE DECAL GLOSS
2	WHITE DECAL MATT
3	BLACK DECAL GLOSS
4	BLACK DECAL MATT
FABRIC FINISH REFER TO LU38547	
A	FABRIC COLOUR 1
B	FABRIC COLOUR 2
C	FABRIC COLOUR 3
D	FABRIC COLOUR 4

NOTE:

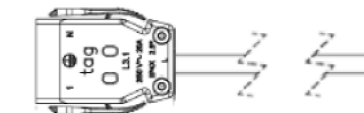

CABLE TYPE: 3 CORE x 2.5mm<sup>2</sup>  
 DESCRIPTION: TAG CONNECTOR LEAD  
 COLOUR: WHITE OR BLACK  
 (REFER TO PURCHASE ORDER)

xx	LENGTH (mm)
05	500
10	1000
15	1500
20	2000
25	2500
30	3000
35	3500
40	4000
45	4500
50	5000

NOTE:

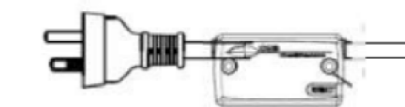

CABLE TYPE: 3 CORE x 1.0mm<sup>2</sup>  
 DESCRIPTION: AUSTRALIAN PLUG LEAD WITH THERMAL OVERLOAD  
 COLOUR: WHITE OR BLACK  
 (REFER TO PURCHASE ORDER)

xx	LENGTH (mm)
05	500
10	1000
15	1500
20	2000
25	2500
30	3000
35	3500
40	4000
45	4500
50	5000

**PART NUMBER:** (REFER CONFIGURATION)XxxXX  
 NOTE - \* - CLAMP TYPE - (S = ABOVE DESK OR Z = UNDER DESK)  
 X - LEAD TYPE (TAG = T OR 3PIN PLUG = I)  
 xx - LENGTH - 05 / 10 / 15 / 20 / 25 / 30 / 35 / 40 / 45 / 50  
 XX - COLOUR - W / B + 1 / 2 / 3 / 4 +(OPTIONAL) A / B / C / D

<b>CUSTOMER SIGNATURE:</b>	<b>TOLERANCES UNLESS OTHERWISE STATED:</b>	 <b>CMS Electracom</b> COPYRIGHT © 2020
<b>MATERIAL:</b> PC FR	X ±0.5 X.X ±0.2 X.XX ±0.1 X.XXX ±0.05 ANG ±0.5°	
<b>FINISH:</b> FINE EDM / POLISHED / FABRIC		<b>TITLE:</b> NOVA TRIO AU CONFIGURATIONS
<b>COLOUR:</b> REFER TABLE		<b>DRAWING:</b> LU39296
THIS DRAWING & ASSOCIATED CAD FILES ARE ISSUED IN THE STRICTEST CONFIDENCE AND ARE ONLY TO BE USED IN THE COMMERCIAL INTERESTS OF CMS ELECTRACOM PTY LTD	DRAWN IN mm TO AS1100 DO NOT SCALE	<b>REV:</b> 1
		<b>A3</b>
SCALE 1:2		SHEET 2 OF 4