

# BARCOOL<sup>®</sup>

**MINI BARS**

**Barcool  
25/30/40/50**



PLEASE READ AND FOLLOW ALL SAFETY RULES AND OPERATING INSTRUCTIONS BEFORE USE

**INSTRUCTION MANUAL**

**CONTENTS**

Indication of parts.....	3
Instruction for use.....	4
Installation instructions.....	5
Change the swing hinge .....	6
Trouble shooting guides.....	6
Electric diagram .....	7
Energy saving tips .....	7
Specification tables .....	7
Product function description .....	8

**Thank you very much for purchasing this product. Before using your new refrigerator, please read this user manual to ensure that you get the maximum benefit from it.**

**WARNINGS:**

*Before using the appliance for the first time and installing, please read this user manual to ensure that you gain the maximum benefit from it.*

1. This appliance is not intended for use by persons (including children) with reduced physical, sensory or mental capabilities, or lack of experience and knowledge, unless they have been given supervision or instruction concerning use of the appliance by a person responsible for their safety.
2. Children should be supervised to ensure that they do not play with the appliance.
3. This appliance can be used by children aged from 8 years and above and persons with reduced physical, sensory or mental capabilities or lack of experience and knowledge if they have been given supervision or instruction concerning use of the appliance in a safe way and understand the hazards involved. Children should not play with the appliance. Cleaning and user maintenance should not be made by children without supervision.
4. If the supply cord is damaged, it must be replaced by the manufacturer, its service agent or similarly qualified person in order to avoid a hazard.
5. To avoid a hazard due to instability of the appliance, it must be fixed in accordance with the instructions.
6. When positioning the appliance, ensure the power cable is not trapped or damaged.
7. Do not locate multiple extension socket-outlets or portable power supplies at the rear of the appliance.
8. Keep ventilation areas open and clear, if the appliance is in an enclosure or in a built-in structure, ensure it is clear of obstruction and has adequate ventilation.
9. Do not use mechanical devices or other means to accelerate the defrosting process, other than those recommended by the manufacturer.
10. Do not damage the refrigerant circuit.
11. Do not use electrical appliances inside the storage compartments of the appliance, unless they are of the type recommended by the manufacturer.
12. Do not store explosive substances such as aerosol cans with a flammable propellant in this appliance.
13. This appliance is intended to be used in household and similar applications such as;
  - staff kitchen areas in shops, offices and other working environments;
  - farm houses and by clients in hotels, motels and other residential type environments;
  - bed and breakfast type environments;
  - catering and similar non-retail applications.
14. To avoid contamination, please follow the following instructions:
  - Opening the door for long periods can cause a significant increase of the temperature in the compartments of the appliance.
  - Clean surfaces that can come in contact with food and accessible drainage systems.
  - If the refrigerating appliance is left empty for long periods, switch off, defrost, clean, dry, and leave the door open to prevent mould developing within the appliance.

**Note:** *This appliance contains flammable refrigerant R600a and foaming agent cyclopentane. Please keep in the upright vertical position.*

**Please send it to your local WEEE disposal recycling centre when you discard it.**

Indication of Parts

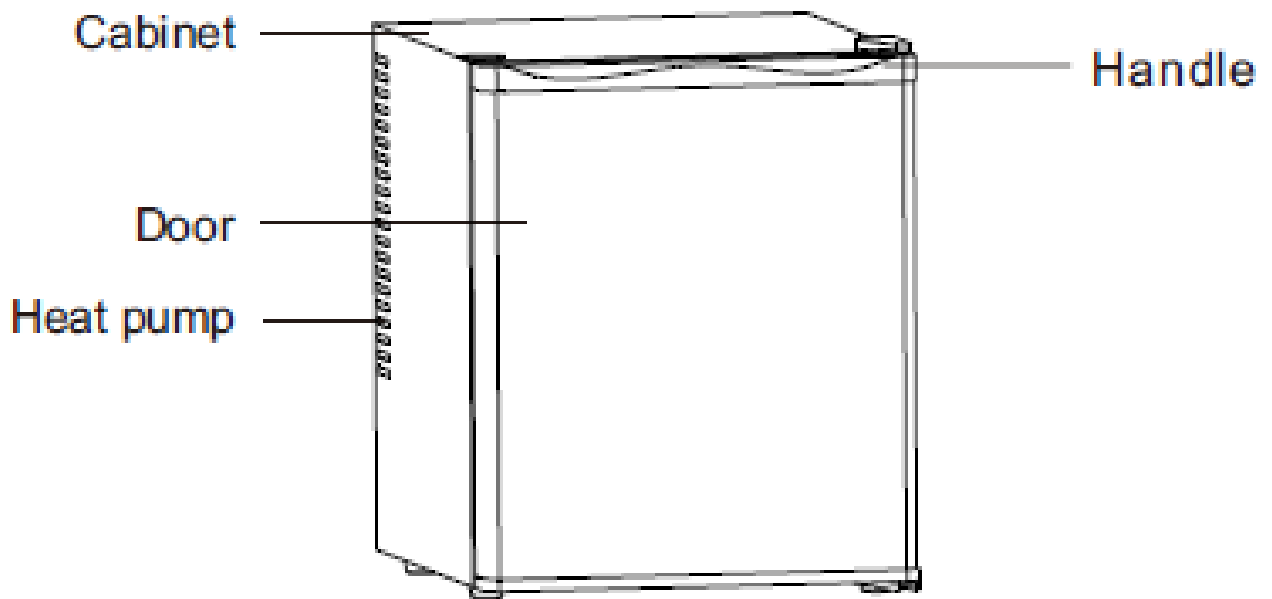
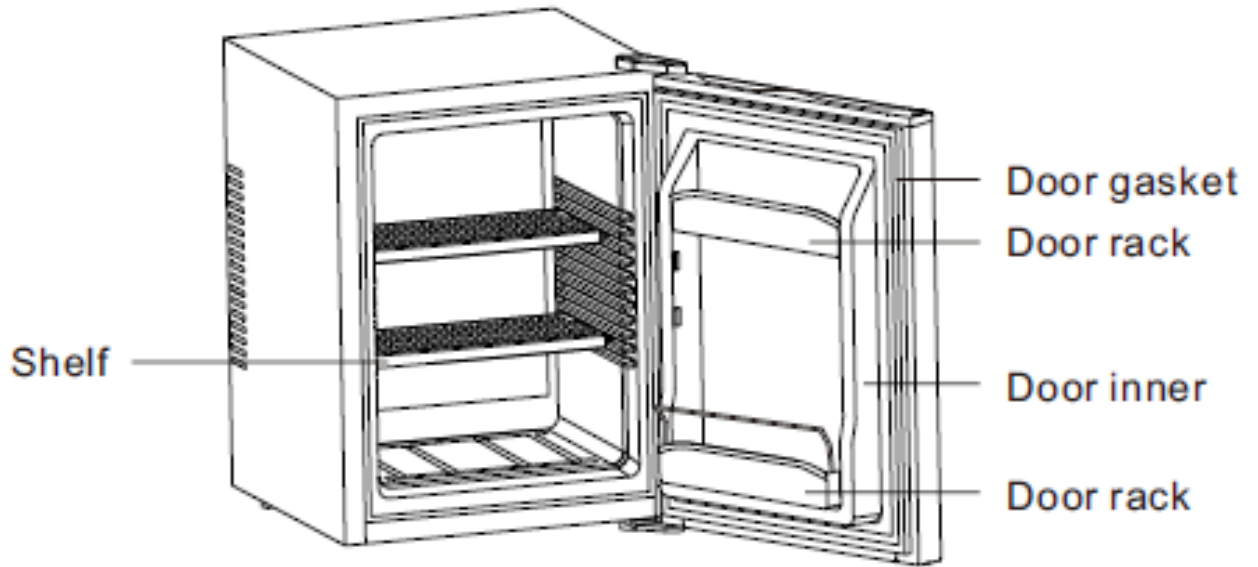

## Operating your Refrigerator

### Temperature control

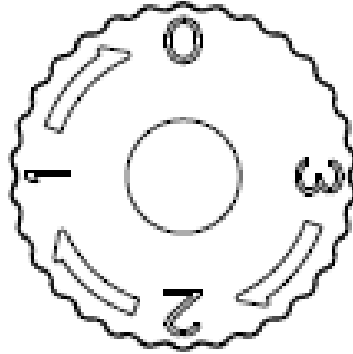

#### Setting the Temperature Control:

- Your refrigerator has only one control for regulating the temperature.
- The temperature control is located on the top of the refrigerator inside.
- To control the internal temperature, adjust the control knob according to the ambient temperature or purpose of use.
- The range of the temperature control is from position “0” to “3”.

#### Instruction for use

##### Note

- Position your refrigerator so that the plug is accessible.
- Keep your refrigerator out of direct sunlight.
- Do not place next to a heat generating appliance.
- Do not place it directly on the ground. Provide a suitable stand or table
- The refrigerator will have better performance at an ambient of 20-25 degrees; We suggest the refrigerator should be turned off if the ambient temperature is lower than 10 degrees.
- After plugging the appliance in, allow the unit to cool down for 2-3 hours before placing items into the refrigerator.
- Ventilation is very important for this kind thermoelectric refrigerator; The inside PCB can be damaged in the event of poor or inadequate ventilation; It will also reduce the life of the refrigerator.

#### Power Supply

- The refrigerator must be connected to a properly earthed socket in line with relevant valid regulations before operating;
- Check the data label for voltage and frequency that corresponds to your local electricity supply

## Installation Instruction

*When installing this Mini-Bar Refrigerator, ventilation should be considered seriously, please refer to the following:*

- There should be at least 200 cm<sup>3</sup> for ventilation in total
- The following four pictures show four different installation ways
- This refrigerator is designed to be free standing, and should not be recessed or completely built-in (Fully enclosed cupboard). Allow 5cm of space on the sides of the refrigerator, which allows the proper air circulation required for good operation and a very minimum of 2cm on the back wall.
- Place your refrigerator on a surface that is strong enough to support it when it is fully loaded.
- Locate the refrigerator away from direct sunlight and sources of heat (stove, heater, radiator, etc.). Direct sunlight may affect the acrylic coating and heat sources may increase electrical consumption. Extreme cold ambient temperatures may also cause the unit not to perform properly.
- This refrigerator uses thermoelectric refrigeration technology (no compressor) and is not designed for storage in cold areas like garages, warehouses or outdoors
- Avoid locating the unit in moist areas.
- Plug the refrigerator into an exclusive, properly installed-grounded wall socket. Do not under any circumstances cut or remove the third (ground) prong from the plug. Any questions concerning power requirements please get in touch with a manufacturer.
- After plugging the refrigerator into a mains wall socket, allow the unit to cool down for at least 2-3 hours before placing items inside.

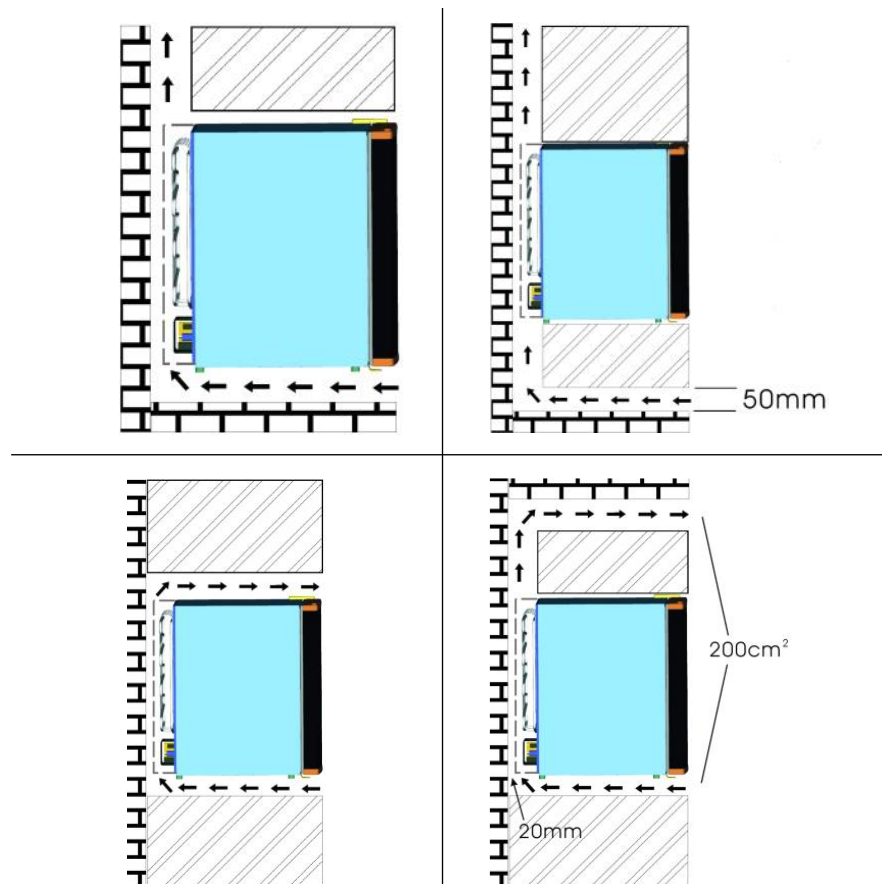

## Changing the Door Hinge

*This refrigerator has the capability of the door opening from either the left or right side. The unit is delivered to you with the door opening from the left side. Should you desire to reverse the opening direction, please follow the below instructions. **Note: If needed there may be a spare directional hinge included in the bag.***

- Remove the hinge cover with a flat head screwdriver from the rear, and pull forward
- Remove the three screws from right hinge on the upper and lower hinges
- Remove the hinge (upper and lower) completely away along with the door
- Move the hinges to the opposite side, fixing them with the same screws you removed before. Re-fit the door and level with spirit level. Re-fit the hinge cover / hinge screw sticker if applicable.

## Troubleshooting Guide

PROBLEM	POSSIBLE CAUSE
Refrigerator does not operate	Not plugged in. The circuit breaker tripped or a blown fuse.
	The room temperature is hotter than normal. The door is opened too often. The door is not closed completely. The temperature control is not set correctly. The door gasket does not seal properly. The refrigerator does not have the correct clearances. Abnormal voltage.
The light does not work.	Not plugged in. The circuit breaker tripped or a blown fuse. The LED light needs replaced
Vibrations.	Check to assure that the refrigerator is level.
The door will not close properly.	The refrigerator is not level. The door was reversed and it was not properly installed The gasket is dirty. The shelves or door pocket holders are out of their correct position.

## Electric Diagram

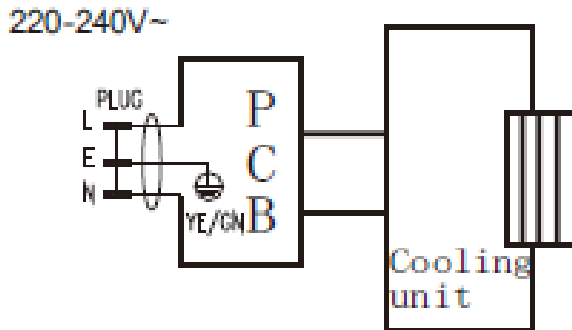

## Energy Saving Tips

- The refrigerator should be located in the coolest area of the room, away from heat producing appliances, and out of the direct sunlight.
- Overloading the refrigerator forces the thermoelectric cooling system to run for longer.
- Reduce door openings and extended searches, remove as many item as needed at one time, and close the door as soon as possible.
- One characteristic of mini-bar units is the length of time it requires to recover from having the door opened and shut frequently. It may be necessary to wait longer for the temperature to return to its former level once the door has been opened for too long. This is normal for this type of unit.
- Heat-pipe technology costs just pennies to operate. It is environmentally friendly due to no CFC's and HCFC's used.

## Specification Table

MODEL NO.	BARCOOL BAR 25 / 30 / 40 / 50 LED
Net Capacity (liters)	19 / 24 / 33 / 40
Voltage (V)	220-240V
Frequency (Hz)	50
Rated Power (W)	58
Dimension WxDxH (mm)	403x348x451 / 380x440x465 / 402x435x549 / 403x482x553
Packing WxDxH (mm)	480x425x500 / 455x515x545 / 480x512x619 / 479x561x620
Net Weight (kg)	9.8 / 10.7 / 11.7 / 12.0
Gross Weight (kg)	12.17 / 13.4 / 15.0 / 16.12



**PRODUCT FUNCTION DESCRIPTION**

- It is intended to be used exclusively for the mini bar cellar.
- This refrigerating appliance is not suitable for the freezing operation.
- The mini bar is recommended to be operated at +12°C
- The following arrangement of shelves is recommended for energy consumption to be used as efficiently as possible.

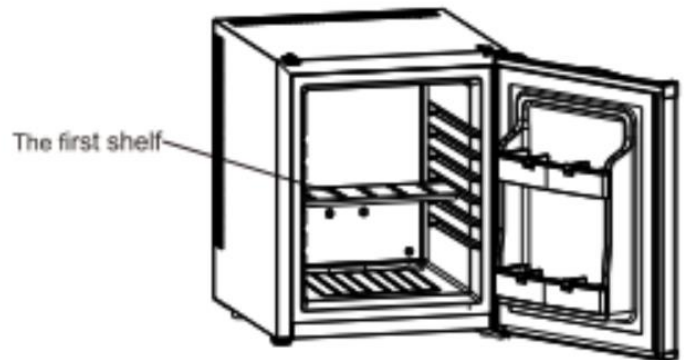
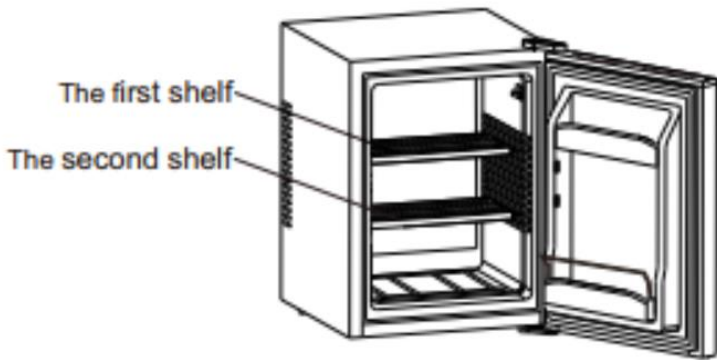

- When the surrounding temperature is 25 C and the mini bar has no products loaded, it will take around 3.5 hours to decrease the interior temperature from 25°C to 12°C
- The cellar is recommended to be operated at 12°CThe energy consumption is shown in the table below. If the setting temperature is higher than 12,°C the energy consumption will be lower. If the setting temperature is lower than 12,°C the energy consumption will be higher.

MODEL NO.	ENERGY CONSUMPTION
BAR25LED	122 kWh/annum
BAR30LED	130 kWh/annum
BAR40LED	162 kWh/annum
BAR50LED	193 kWh/annum

**Correct disposal of this Product**

This symbol on the product, or on its packaging, indicates that this product may not be treated as household waste. Instead, it should be taken to the appropriate waste collection point for the recycling of electrical and electronic equipment. By ensuring this product is disposed of correctly, you will help prevent potential negative consequences for the environment and human health, which could otherwise be caused by the inappropriate waste handling of this product. For more detailed information about the recycling of this product, please contact your local council or your household waste disposal service.

*The above information is in accordance with EU and UK Ecodesign and energy labelling regulations*

*For FAQs and more information, please visit:*



[www.subcold.com](http://www.subcold.com)



[@subcoldltd](https://www.facebook.com/subcoldltd)



01506415564 (UK Office Hours)



[@subcold\\_official](https://www.instagram.com/subcold_official)



[sales@subcold.com](mailto:sales@subcold.com)

**Subcold Ltd**

1 Drummond Square  
Brucefield Industrial Estate  
Livingston, West Lothian  
EH54 9DH  
United Kingdom

**Eurolink Europe**

**Compliance Limited**

25 Herbert Place  
Dublin D02 AY86  
Republic of Ireland

**BARCOOL<sup>®</sup>**