

STANDARD AND OPTINAL EQUIPMENTS

● Safety equipments

	STD	LC	Dozer
ISO12117-2 Fops top guard ISO 10262 LEVEL 2	⊙	⊙	⊙
Safety lock lever	⊙	⊙	⊙
Seat-belt	⊙	⊙	⊙
Emergency engine stop switch	⊙	⊙	⊙
Emergency escape hammer	⊙	⊙	⊙
Rear view mirror (light&left side)	⊙	⊙	⊙
Rear view camera	⊙	⊙	⊙
Side view camera	●	●	●
Working light (slewing table right side, boom left side)	⊙	⊙	⊙
Optional working light (cab left and right side)	●	●	●
Optional working light (boom right side)	●	●	●
LED working lights	●	●	●
Boom/arm anti-drift valve	⊙	⊙	⊙
Slewing anti-counter action	⊙	⊙	⊙
Automatic parking brake (slewing table)	⊙	⊙	⊙
Automatic parking brake (traveling)	⊙	⊙	⊙
Fire wall	⊙	⊙	⊙
Falling prevention handrail	⊙	⊙	⊙
Battery disconnect switch	⊙	⊙	⊙
Caution indication	⊙	⊙	⊙
Cabin lower guard	●	●	●
Cabin front guard	●	●	●
Cabin head guard	●	●	●
Step on side of cab	●	●	●
Fire extinguisher	●	●	●
Additional electric horn	●	●	●
Traveling alarm	●	●	●
Swing interlocking warning lamp	●	●	●
Loud speaker	●	●	●

● System

	STD	LC	Dozer
APC mode (A, P and E)	⊙	⊙	⊙
Front attachment mode	⊙	⊙	⊙
Auto-slow, one touch slow	⊙	⊙	⊙
Automatic transmission for traveling	⊙	⊙	⊙
2 speed modes for traveling	⊙	⊙	⊙

● Cabin

	STD	LC	Dozer
6 points viscous dumping cab suspension	⊙	⊙	⊙
Pull up front window	⊙	⊙	⊙
7 inch touch screen control LCD monitor	⊙	⊙	⊙
Double slide operator seat	⊙	⊙	⊙
Seat suspension adjustable to operator's weight	●	●	●
Automatic air conditioner (pressurized)	⊙	⊙	⊙
Defroster	⊙	⊙	⊙
Large capacity heat & cold insulation box	⊙	⊙	⊙
Intermitted windshield wiper	⊙	⊙	⊙
AMFM radio	⊙	⊙	⊙
Two stereo speakers	⊙	⊙	⊙
LED interior light	⊙	⊙	⊙
Cup holder	⊙	⊙	⊙
Helmet hook	⊙	⊙	⊙
24V electric supply port	⊙	⊙	⊙
Transparent roof hatch with sun visor	●	●	●
Sun shade	●	●	●
Sun visor	●	●	●
Rain visor	●	●	●
Ash tray (with cup holder)	●	●	●
12 volt power supply	●	●	●
USB port (x2)	●	●	●
Seat cover	●	●	●

● Piping and other

	STD	LC	Dozer
Service port (1 spool)	⊙	⊙	⊙
High performance filter	●	●	●
Additional piping for breaker & crusher (with manual selector valve)	●	●	●
Additional piping for breaker & crusher (with electric control selector valve)	●	●	●
Additional piping (for crusher)	●	●	●
Additional piping (for rotator)	●	●	●
Control pattern change valve (ISO-SAE)	●	●	●
Air cleaner double element	⊙	⊙	⊙
Additional counter weight (1 500kg)	●	●	●
Under cover slewing table (reinforced)	●	●	●
Electric refueling pump	●	●	●
Specification for cold region	●	●	●
Designated paint	●	●	●
Tool set	⊙	⊙	⊙

● Working equipments

	STD	LC	Dozer
0.25m ³ bucket	●	●	●
0.35m ³ bucket	●	●	●
0.40m ³ bucket	●	●	●
0.45m ³ bucket	●	●	●
0.50m ³ bucket	⊙	⊙	⊙
0.55m ³ bucket	●	●	●
0.60m ³ bucket	●	●	●
Plate to close spaces between teeth of bucket	●	●	●
Arm (2.50m)	⊙	⊙	⊙
Arm (3.00m)	●	●	●
Various type of reinforced arm	●	●	●
Standard boom (4.65m)	⊙	⊙	⊙
Bracket on boom for small swing radius (4.65m)	●	●	●

● Traveling equipments

	STD	LC	Dozer
Grouser shoe			
500mm	⊙	?	⊙
500mm (reinforced)	●	●	●
600mm	●	?	●
700mm	⊙	?	?
Dozer blade			
500mm shoe	?	?	●
600mm shoe	?	?	●
Cover on the bottom face of traveling frame	⊙	⊙	⊙
Traveling motor cover (reinforced)	●	●	●
Track guard			
1 pc each side	●	?	●
2 pcs each side	●	?	●
3 pcs each side	●	?	●

⊙ Standard equipments ● Option ? No setting

BUCKET

Type of bucket		Backhoe bucket						
Bucket capacity	m ³ , ISO	0.25	0.35	0.40	0.45	0.50	0.55	0.60
Bucket width	W/O side cutters, mm	540	695	745	875	890	965	1,090
	with side cutters, mm	630	785	835	965	980	1,055	1,180
Number of bucket teeth		3	4	4	4	5	5	5
Shape of bucket								
Standard boom +	Standard arm (2.50m)	●	●	●	●	●	▲	□
	Long arm (3.00m)	●	●	●	▲	▲	×	×

● General purpose ▲ Light work □ Loading × Unusable
 ● Yellow colored area means standard.

TRACK SHOES

Type of shoes		Grouser shoe			
Specifications for main body	Shoe width	mm	500 [500reinforced]	600	700
	Operating weight	kg	12,900 [13,400]	13,100	13,400
	Distance between shoe edge of both side	mm	2,490	2,590	2,690
	Ground pressure	kPa	41 [40]	34	30
		kgf/cm ²	0.42 [0.41]	0.35	0.30

Ground pressure when equip standard bucket and arm.
 [] HD512LC-7
 ● Yellow colored area means standard.

NOTE : Illustrations may include optional equipment. KATO products and specifications are subject to improvements and changes without notice. Mentioned figures are approximate.

● Contact for enquiry:



Available through



earthmovingwarehouse.com.au

0459 927 346 (0459 WAREHOUSE)
 Shed C1/C2 194 Zillmere Road,
 Boondall Brisbane 4034
 QLD



HD512-7
 REGZAM | HYDRAULIC EXCAVATOR



7 High performance & Environment-friendly KATO conventional excavator

Environment-friendly

- ▣ Tier4/Stage4 compliant engine
- ▣ New control valve reduces the fuel consumption

Durability

- ▣ New standard bucket
- ▣ The traveling body has been enhanced

Safety

- ▣ New ROPS cabin
- ▣ New engine neutral start mechanism

Comfortable cabin

- ▣ New air conditioner
- ▣ Complete interior
- ▣ Operability is up
- ▣ Pressurizing function

New APC

- ▣ Large size liquid crystal display
- ▣ Touch screen control
- ▣ Rear and side view monitor are available

Maintainability

- ▣ Good access to service parts
- ▣ Daily cleaning has been facilitated
- ▣ Safe features for maintenance

High productivity and comfort operability

1 High performance and environment-friendly Isuzu engine



Selective Catalytic Reduction (SCR) system
 The SCR system cuts the NOx (nitrogen oxides), PM (particulate matter) and NMHC (non-methane hydrocarbon). The emission control is compliant with Stage 4 and Tier 4.

EGR (Exhaust Gas Recirculation) system
 The large capacity water-cooled EGR cooler suppresses the NOx.

2 Selective Catalytic Reduction (SCR) system

The SCR system provides chemical reaction between Urea and NOx in emission. This reaction generates Nitrogen and Water which are friendly to the environment.

The large capacity DEF (Desel Exhaust Fluid) tank

DEF replenishment is every 1 time per 5 times of fuel replenishment (subject to working condition). DEF tank is located inside of the tool box and easy to access.

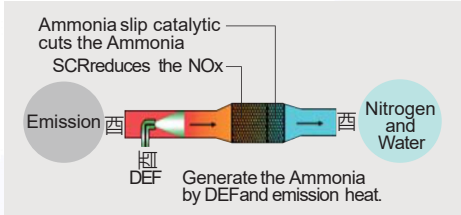

3 High mileage

Diameter of the boom cylinder hose and bucket cylinder hose have been increased. It reduces the pressure loss and minimizes the power loss.



4 New control valve

The new control valve provides better operability. Feeling of the leveling operation has been improved by providing the arm-semi-parallel circuit and the arm spool. The productivity is up than before.



NOx is decreased by **88%**

The fuel economy is increased by **4%** (compared with HD512-6 at A mode)



1 New bucket

Bucket bottom

New bucket bottom design protects welded portion from wear. Thicker plate has been provided to the bottom and durability has up.

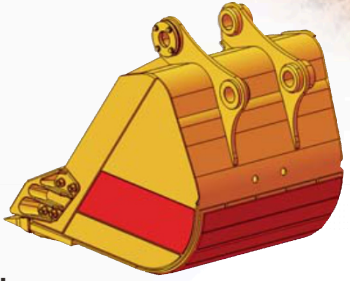

Arm adjustment mechanism

The new mechanism to adjust the rattling of the arm. Easy to adjust by removing the shim.

Side-cutter

By securing the bolt to 4 corners of side-cutter, the load to the bolt has been reduced.

Reinforced bucket

Bucket bottom reinforcement plates have been provided in horizontal direction. Worn plates are replaceable.

Digging force

Max. arm digging force at high power mode **69kN**
 Max. arm digging force at high power mode **72kN**

Max. bucket digging force **94kN**
 Max. bucket digging force at high power mode **98kN**

Working range

Max. digging radius **8,300mm**
 Max. digging depth **5,590mm**
 Max. digging height **8,740mm**

2 New traveling body

Idler frame has enhanced

There is a bracket for the idler wheel. Durability is up.

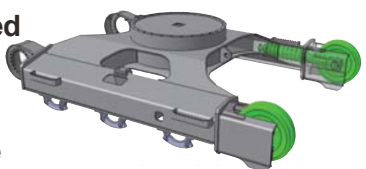

New X-shape rear frame

The traveling motor pipe is storable to the frame. Cross section area has been increased and rigidity has improved.

Track guard (option)

New design enhances wear resistance.

New shock absorber

The adjustable cylinder is integrated into the shock absorber. Component parts have reduced.

Air cleaner

The Double-element collects the dust in the air.



Expansion tank

The expansion tank has been equipped to the radiator. It increases air breeding and cooling performance.



Dozer edge

New mechanism is available to replace the edge.

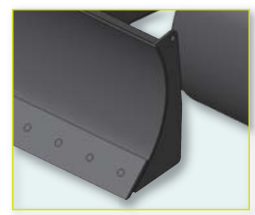

Safer cab with various features

The KATO original cab is durable and smart design. The cabin is compliant with ROPS direction (ISO12117-2). It secures the safety and protection of the operator from roll-over accident. The cabin is also compliant with ISO10262 (Top guard level) and protect the operator from falling objects.

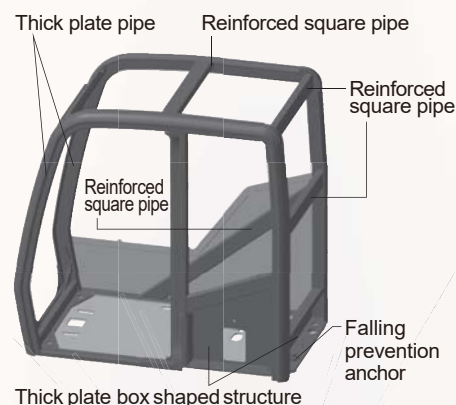

Window and rise up wiper

The large size right window and the rise up wiper secure excellent view. The wiper is storable to the right pillar.



Polycarbonate door window

Polycarbonate prevents the crack comes from scattering stone. Hard coating which has provided to surface secures high resistance to yellowing or scratch.



Safety lock lever

The new electronic control lock mechanism enhances safe and prevents miss operation. It locks the hydraulic circuit in case the console is jumped up. The engine start operation is active only when the lever is applied to lock position.



Handrail and step

To prevent falling accident, the handrail has been provided to the upper structure. The large size anti-slip step enables operator to access the upper structure safer.

Other safe features

- Rearview camera
- Sideview camera (option)
- Emergency engine stop switch
- Emergency escape hammer
- Seatbelt
- Firewall
- Fanguard
- Retractable side mirror
- LED working light (option)
- Fire extinguisher (option)

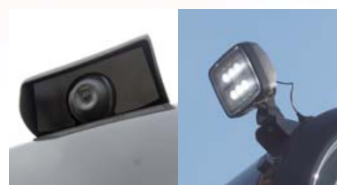

Best comfort and high efficiency

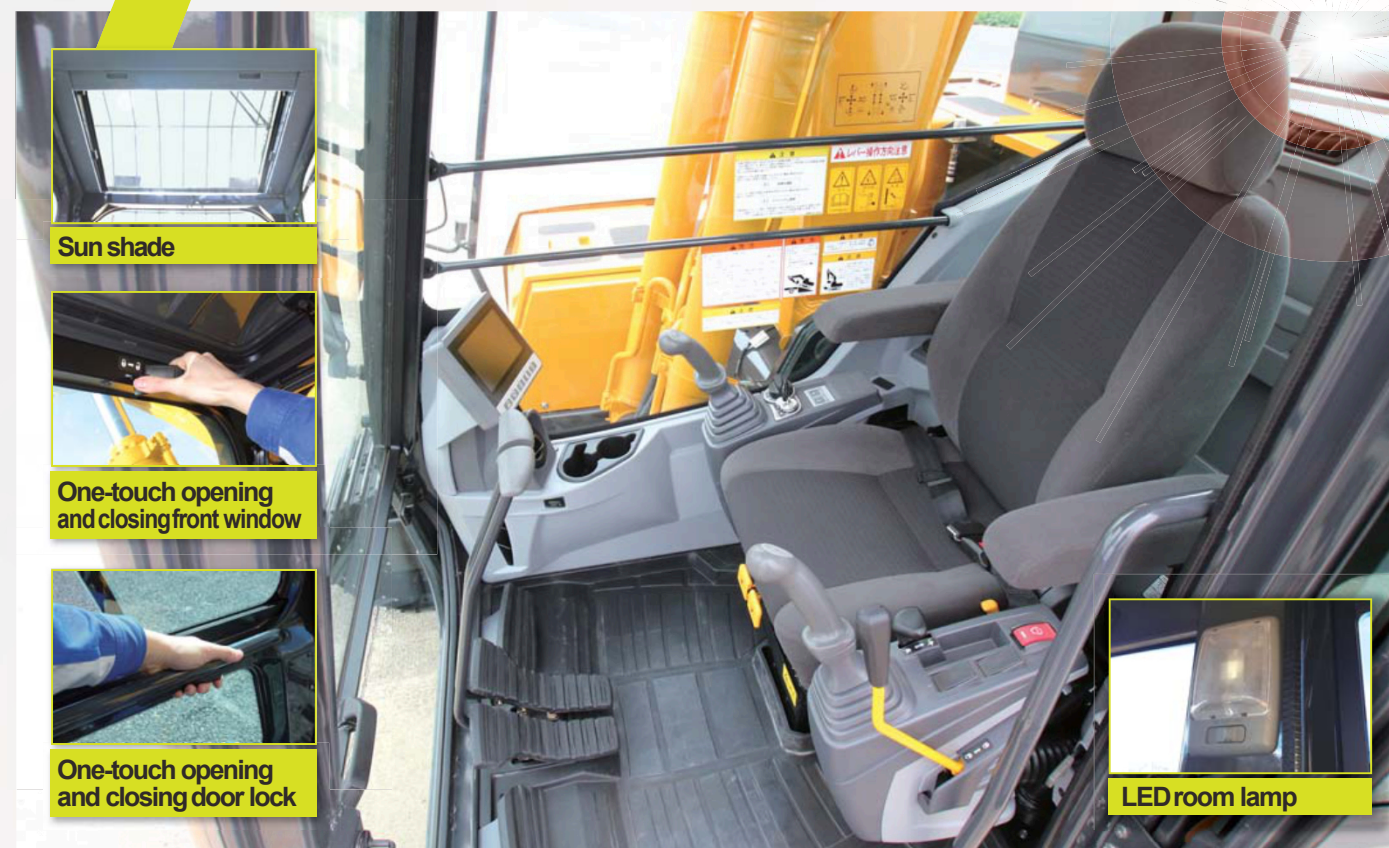

Sun shade

One-touch opening and closing front window

One-touch opening and closing door lock

LED room lamp

Heat&cold insulation box

It is capable to store 6 drink bottles (500ml).



Rear stowage space

It is capable to stow such as 2l size drink bottle.



New foot rest arrangement

The foot rest has been relocated to optimum position. Replacement of the floor mat has become easier.



Drink holder

Soft material is used for the drink holder. Various arrangements are available.



New operation lever

Operation switches are arranged to up and bottom. Round shape grip is easy to handle.



Pressurized cabin

It prevents dust by enhancing the airtightness.

Air conditioner

- Air volume is increased by 26%
- Filter is paper type

Other cabin features

- Seat suspension with large size shock absorber (option)
- Luggage space
- Helmet hook
- AM/FM radio with 2 speakers
- USB port (option)
- 12V electric port (option)
- Ash tray (option)
- Sun visor (option)
- Rain visor (option)
- Transparent roof hatch (option)



Luggage space



USB port (option)

7 New APC for smart operation



Visibility

Large and high resolution display
 The display is 7 inch size and IPS liquid crystal display provides high quality image.

Safety

Rear view camera for standard feature
 Operator is able to confirm rear and side view through dual view display (side view camera is option).



It indicates rear and side view at same time.

Operability Touch screen control is available for all operation.



Mode selection
 Pull-down menu enables operator to confirm all mode on the display at once.



Alarm message
 The display indicates various alarms. It also indicates the DEF aqueous fluid replenishing timing.



Air conditioner
 The air conditioner operation is available on the display.



Various information
 Operator is able to set up to display various information such as maintenance information.

7 High performance and superior maintenance



Fuel main filter
 It is locating on the right-rear position which is easy to access.



High performance bush
 The new dimple design bush keeps the grease longer than before. These have been provided to boom foot, arm foot and arm top.

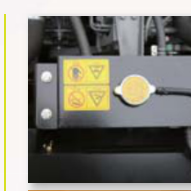

Cooling system
 The cleaning space is available on the upper part of the radiator.
 Parallel configuration of the oil cooler and radiator make maintenance easier.
 It becomes more easily to replace fine meshed insect proof net.

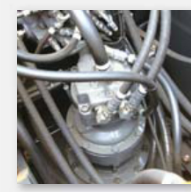

Greasing port for slewing motor
 The extension hose has been provided to the slewing motor. The greasing port is locating which is easy to access.



Traveling body
 Sloop design center-flame and side-flame have been arranged in straight lines. Mud drainage performance is up.



Large capacity tool box
 The large size tool box that is capable to store such as tool set, 10l DEF aqueous fluid container.

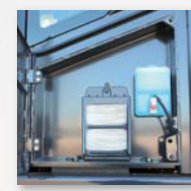

Cab maintenance space
 It is able to replace the filter for the air conditioner and replenish the washer fluid from the cab maintenance space which is locating on outside of the cab.



Battery disconnect switch
 It is capable to shut down the battery completely in non-operation state. The maintenance of electronic devices becomes safer.

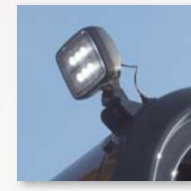

LED light (option)
 The LED lights have been provided to the cab, right-front and the boom.



Technical Specifications

ENGINE

Model..... ISUZU 4JJ1X
 4 cycle intercooler turbo charged diesel engine
 Number of cylinders..... 4
 Bore & Stroke..... 95.4mm X 104.9mm
 Total displacement..... 2,999 L
 Rated output..... 78.5kW/2,000min⁻¹ (ISO 14396)
 76.4kW/2,000min⁻¹ (ISO 9249 Net)
 Max. torque..... 375N·m/1,800min⁻¹ (ISO 14396)
 367N·m/1,800min⁻¹ (ISO 9249 Net)
 Compression ratio..... 16.5:1
 Combustion system..... Direct injection
 Cooling system..... Pressurized water circulated by a Impeller type pump with thermostat
 Lubrication system..... Pressurized oil fed by a gear pump through full-flow and by-pass cartridge filter
 Starter..... Electric, 24V-4.0kW
 Generator..... Alternator, 24V-50A
 Air cleaner..... Double element Dry type filter

HYDRAULIC SYSTEM

Pumps..... Double variable piston pump and gear pump
 Max. discharge flow..... 2x126L/min
 Max. discharge pressure..... 31.4MPa
 Max. discharge pressure (high power / travel)..... 32.9MPa
 Oil filtration..... Full-flow filter with replaceable element, a pilot line filter and suction strainer
 Control valves..... 3+4 section multiple control valves (with one free service circuit)
 Pilot pump..... Gear type
 Oil cooler..... Finned tube, forced ventilation
 Pressure relief valves..... Primary and secondary on each circuit

SWING SYSTEM

Drive..... Axial piston motor with shockless valve and reduction gear.
 Brake..... A hydraulic brake that locks automatically when the swing control lever is in the neutral position and a mechanical parking brake which is applied when the safety lock lever is pulled backwards, the engine is turned off or the swing control lever is in the neutral position.
 Lubrication..... Completely housed and grease bathed
 Max. swing speed..... 13.0min⁻¹

TRAVEL SYSTEM

Drive..... Independent axial piston motor with reduction for each side
 Brakes..... Independent disk parking brake for each side, applied automatically when the travel levers are in the neutral position.
 Track shoes..... 44 each side
 46 each side (LC)
 Track adjustment..... Grease cylinders with recoil springs
 Lubrication..... Sealed-for-life rollers and front idlers with floating seals
 Travel speed..... High 0~5.8km/h
 Low 0~3.3km/h
 Gradeability..... 70% (35°)
 Max. drawbar pull..... 110 kN

DIGGING FORCE (ISO 6015)

Arm (2.50m) digging force..... 69kN at high power..... 72kN
 Bucket digging force..... 94kN at high power..... 98kN

SERVICE DATA

Fuel tank..... 275 L
 Cooling system..... 20.8 L
 Engine oil..... 19.6 L
 DEF tank capacity..... 55 L
 replenishment..... 46 L
 Track drives..... 2x2.1L
 Hydraulic oil tank level..... 80 L
 system..... 158 L
 In standard figure, with the 2.50m arm, 500mm grouser shoes and 0.50m³ (ISO) bucket.
 Operating weight..... 12,900kg
 Ground pressure..... 41kPa

CAB & CONTROLS

Type..... All weather sound suppressed, cab mounted on 6 point viscous mounting.
 Right hand levers..... Controls the boom & bucket
 Inner right hand lever (with foot pedal)..... Controls the right hand track
 Inner left hand lever (with foot pedal)..... Controls the left hand track
 Left hand lever..... Controls the arm & swing
 Pilot control..... Travel, boom, arm, bucket and swing
 Engine throttle..... Electric "Accell dial"
 Meter & gauges..... Hour meter, water temperature DEF and fuel level
 Working lights..... Provided on the boom left side and right front cover
 Lubrication chart..... Inside of the left rear side cover
 Quick Selection of Working Modes.....
 P: Professional mode for experienced operator. Established both power and good response
 A: All-round Multi Purpose Mode for all application from precision work to heavy duty work by stroke of operation levers
 E: ECO Mode for economical works
 Color monitor display with touch screen
 Rear / side View monitor

AIR CONDITIONER

Air conditioner gas contains fluorinated greenhouse gases.
 Industrial designation..... HFC-134a
 Quantity..... 1.0kg
 CO₂ equivalent..... 1.43ton
 Global warming potential (GWP)..... 1430

Dimensions

HD512-7

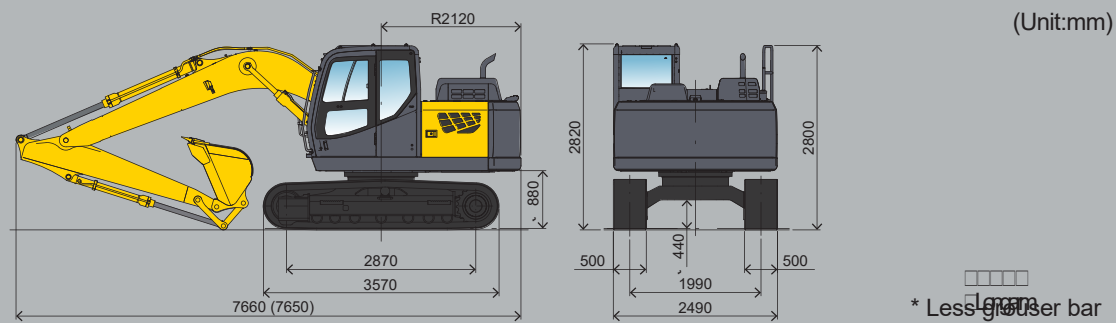

HD512LC-7

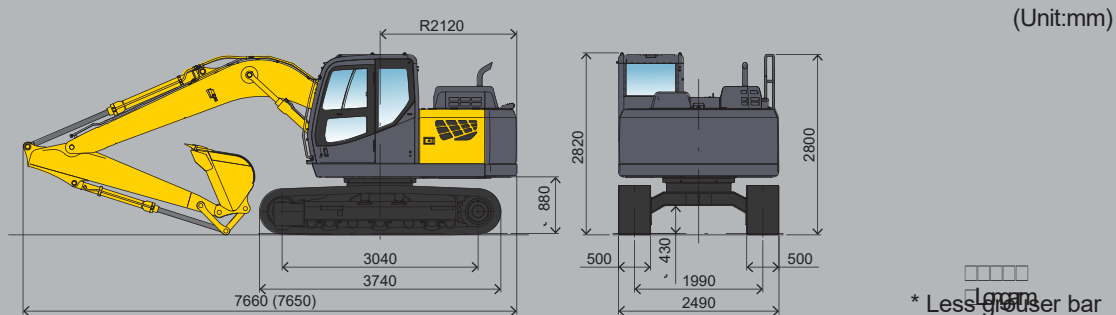

Working Ranges

Standard backhoe

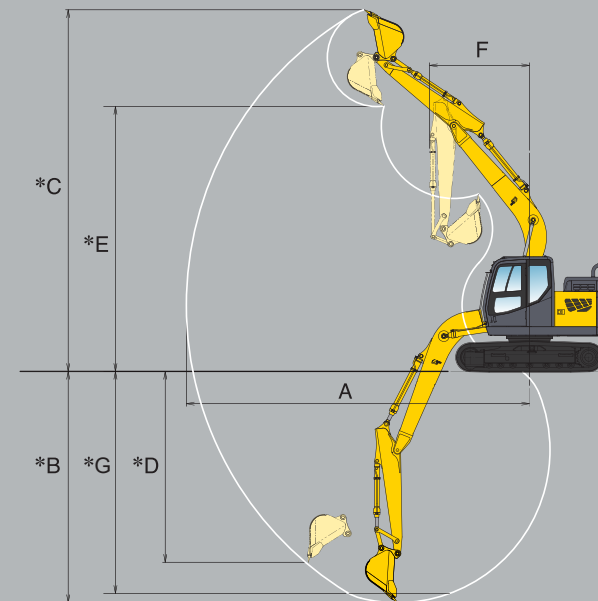

Unit : mm *Less grouser bar

Range	Arm	Standard boom	
		Standard arm 2.50m	Long arm 3.00m
A : Maximum digging radius		8,300	8,770
* B : Maximum digging depth		5,590	6,070
* C : Maximum digging height		8,740	9,070
* D : Maximum vertical wall		4,620	5,030
* E : Maximum dumping height		6,410	6,730
F : Minimum swing radius		2,420	2,720
* G : Maximum digging depth at 2,440mm (8ft) floor length		5,370	5,880

Lifting Capacities

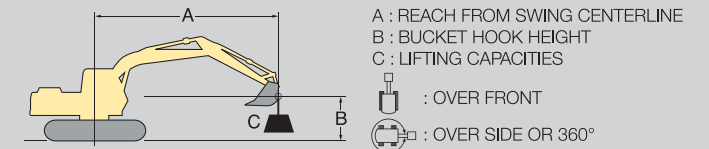

HD512-7 BOOM: 4.65m, ARM: 2.50m, BUCKET: 0.5m³ (430kg), SHOE WIDTH: 500mm, COUNTERWEIGHT: 2,100kg Unit: kg

LIFT POINT HEIGHT B(m)	LIFT POINT RADIUS A(m)								AT MAXIMUM LIFT POINT RADIUS		
	1.50		3.00		4.50		6.00		RADIUS (m)		
6.00									*2090	*2090	5.09
4.50					*2190	*2190	*2400	1,980	*1710	1,550	6.75
3.00			*3960	*3960	*3070	*3070	*2760	1,880	*1740	1,310	7.21
1.50			*5280	*5280	*4190	2,810	2,640	1,760	1,860	1,220	7.34
0.00			*4780	*4780	4,010	2,600	2,530	1,660	1,900	1,230	7.16
-1.50	*5190	*5190	*4790	*4790	3,910	2,510	2,480	1,610	2,130	1,380	6.63
-3.00	*4750	*4750	*5010	4,900	3,940	2,540			2,760	1,810	5.66
-4.50			*6050	5,200					*4860	3,360	3.93

HD512LC-7 BOOM: 4.65m, ARM: 2.50m, BUCKET: 0.5m³ (430kg), SHOE WIDTH: 500mm, COUNTERWEIGHT: 2,100kg Unit: kg

LIFT POINT HEIGHT B(m)	LIFT POINT RADIUS A(m)								AT MAXIMUM LIFT POINT RADIUS		
	1.50		3.00		4.50		6.00		RADIUS (m)		
6.00									*2090	*2090	5.09
4.50					*2190	*2190	*2400	2,050	*1710	1,610	6.75
3.00			*3960	*3960	*3070	*3070	*2760	1,960	*1740	1,370	7.21
1.50			*5280	*5280	*4190	2,920	2,740	1,830	*1880	1,270	7.34
0.00			*4780	*4780	4,160	2,700	2,630	1,730	1,980	1,290	7.16
-1.50	*5190	*5190	*4790	*4790	4,060	2,610	2,580	1,680	2,220	1,450	6.63
-3.00	*4750	*4750	*5010	*5010	4,100	2,640			2,870	1,880	5.66
-4.50			*6050	5,380					*4860	3,490	3.93

NOTE : 1. Lifting capacities are based on ISO 10567.
 2. Lifting capacities shown do not exceed 87% of machine hydraulic capacity or 75% of minimum tipping load.
 3. Capacities marked with an asterisk (*) are limited by hydraulic capacities.
 4. Lifting capacities are based on machine standing on firm, uniform supporting surface. User must make allowances for job conditions such as soft or uneven ground.
 5. Lifting capacities shown should not be exceeded. Weight of all lifting accessories must be deducted from the above lifting capacities.
 6. Capacities apply only to the machine as originally manufactured and equipped by KATO WORKS CO., LTD.
 7. The operator should be fully acquainted with the instruction manual before operating the machine.