

**NOTES:**

**Rewinder with Adjustable Tension Control. 10.5"x12".**

- Max. Roll Diameter: 12" (305mm)
- Max. Media Width: 10.5" (165mm)
- Core Diameter: 3" (76mm)
- Position: Left (L) or Right (R) Specified at Time of Order
- Core Holder: Mechanical Chuck
- Full 5-Year Parts and Labor Limited Warranty

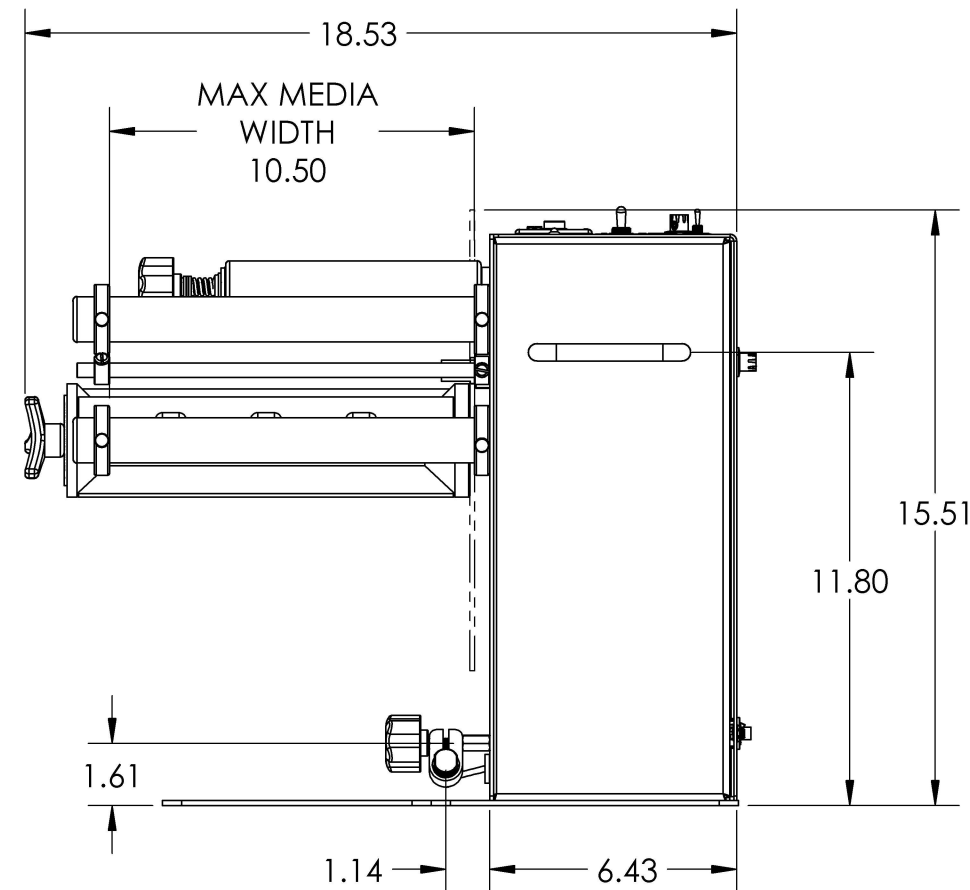
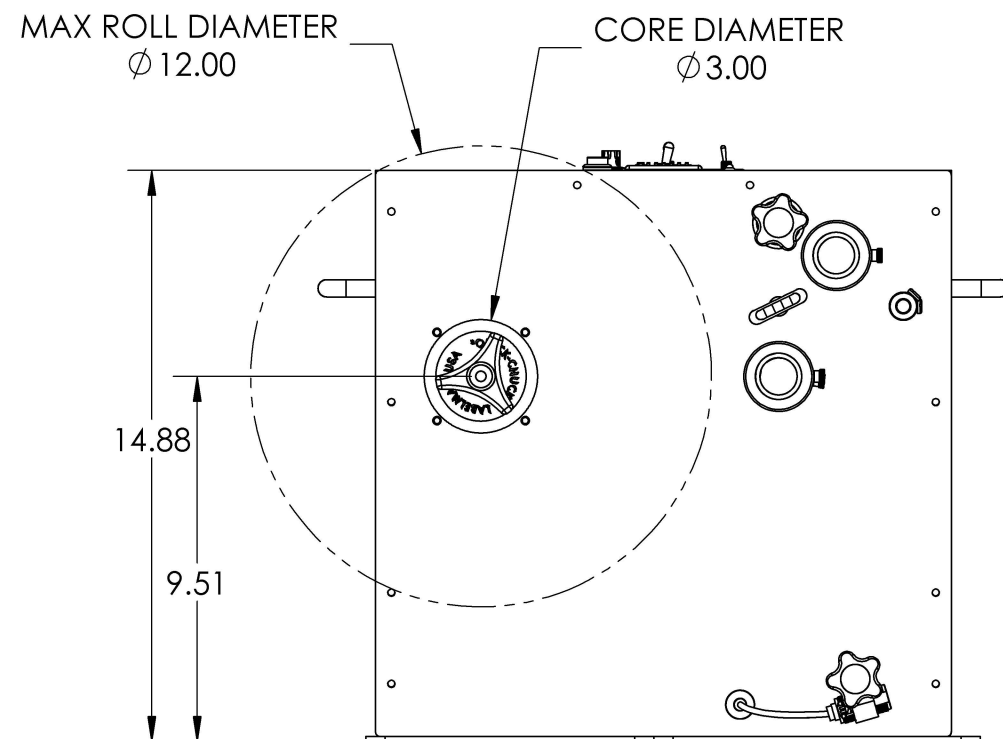
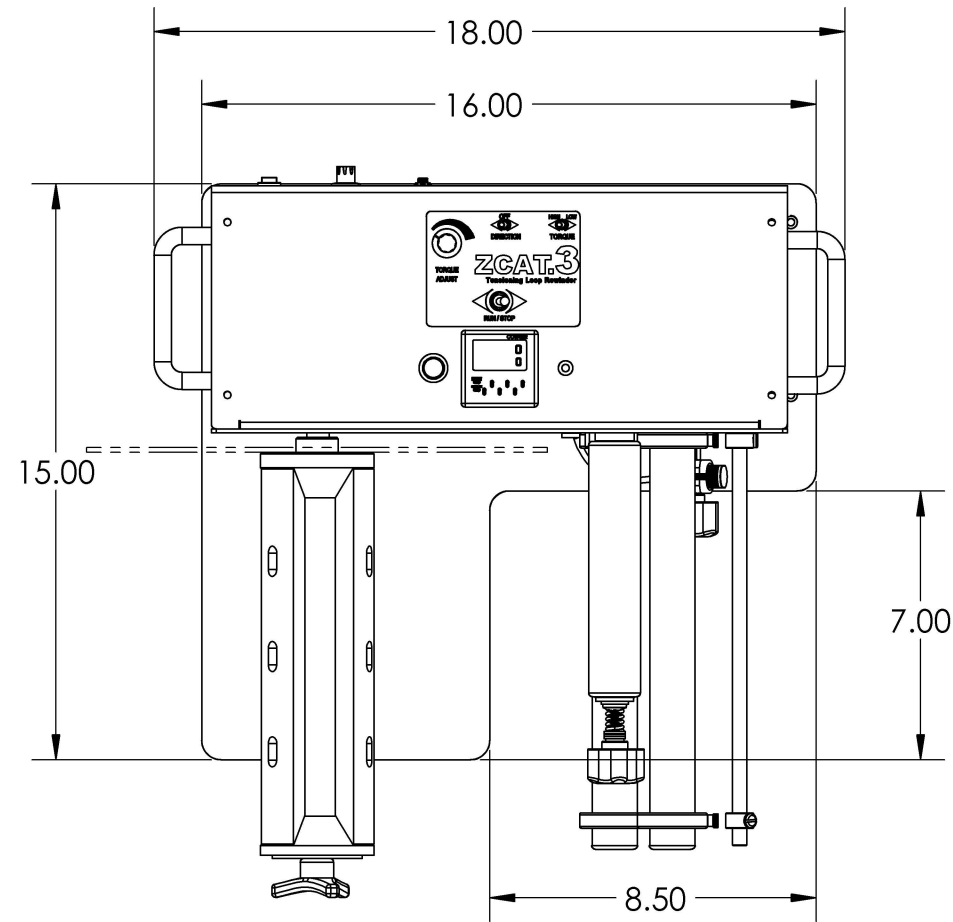

ITEM ID:		
<b>ZCAT - 10(L)</b>		
DRAWN BY:	DATE:	PART NO.
TAH	2/1/2023	80-203-0093
POWER SUPPLY:		INPUT: 100-240VAC 1.4A
PART NO. PS-120	OUTPUT: 24VDC 5.0A	