

**NOTES:**

**Non-Powered Label Unwinder for labels up to 8.5" wide, and roll diameters up to 12".**

- Non-Powered Label Unwinder
- Max. Roll Diameter: 12" (305mm)
- Core Diameter: 3" (76mm)
- Core Holder: Mechanical Chuck
- Max. Media Width: 8.5" (216mm)

Ø 12.00  
 MAX ROLL  
 DIAMETER

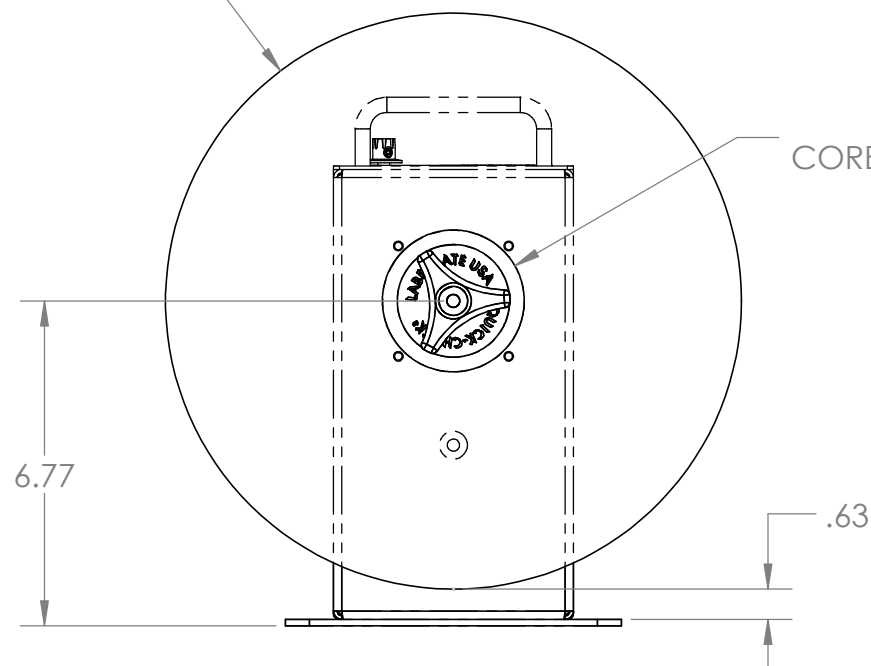

Ø 3.00  
 CORE DIAMETER

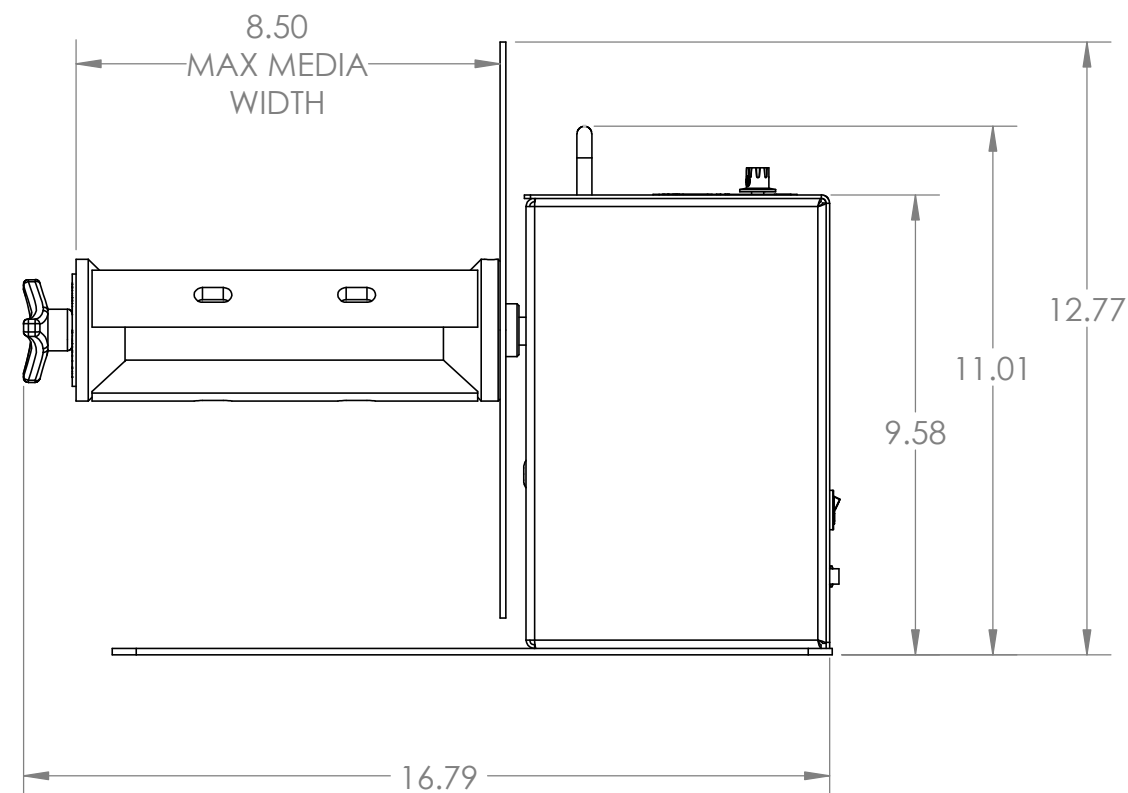

ITEM ID:

**UCAT-1-CHUCK-220**

DRAWN BY: TAH	DATE: 2/1/2023	PART NO. 80-237-0005
------------------	-------------------	-------------------------

POWER SUPPLY: PART NO. NONE	INPUT: OUTPUT:
--------------------------------	-------------------