

NOTES:

Compact "Mini-CAT" Rewinder for media up to 4.5" wide, and roll diameters up to 8.5".

- Max. Roll Diameter: 8.5" (216mm)
- Core Diameter: 3" (76mm)
- Core Holder: Fin-Style
- Max. Media Width: 4.5" (114mm)
- Full 5-Year Parts and Labor Limited Warranty

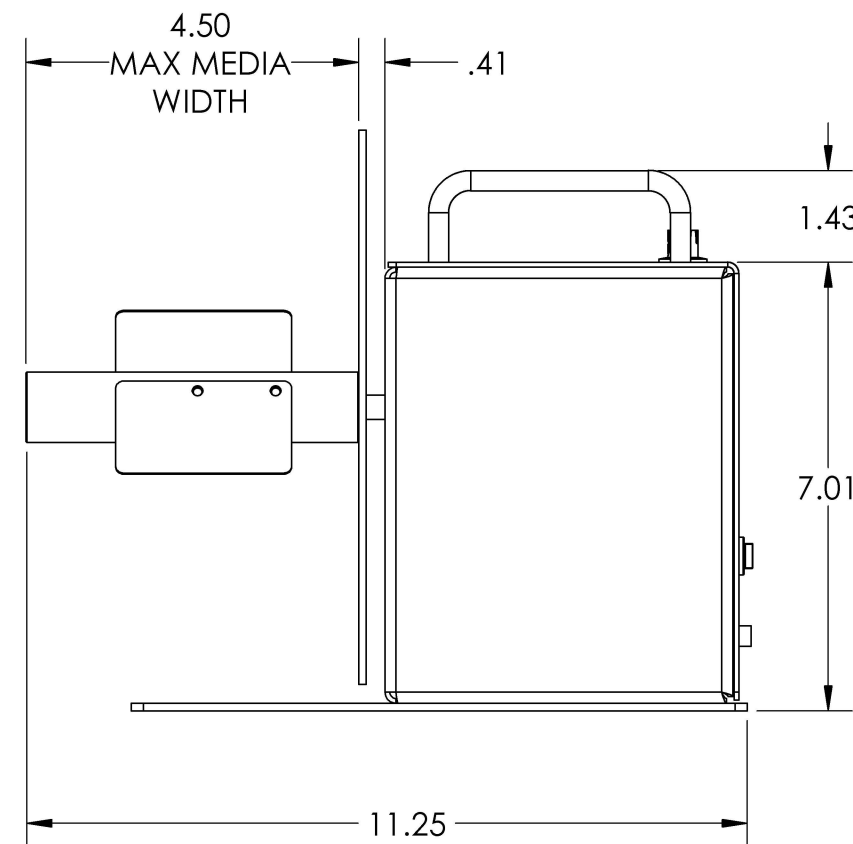
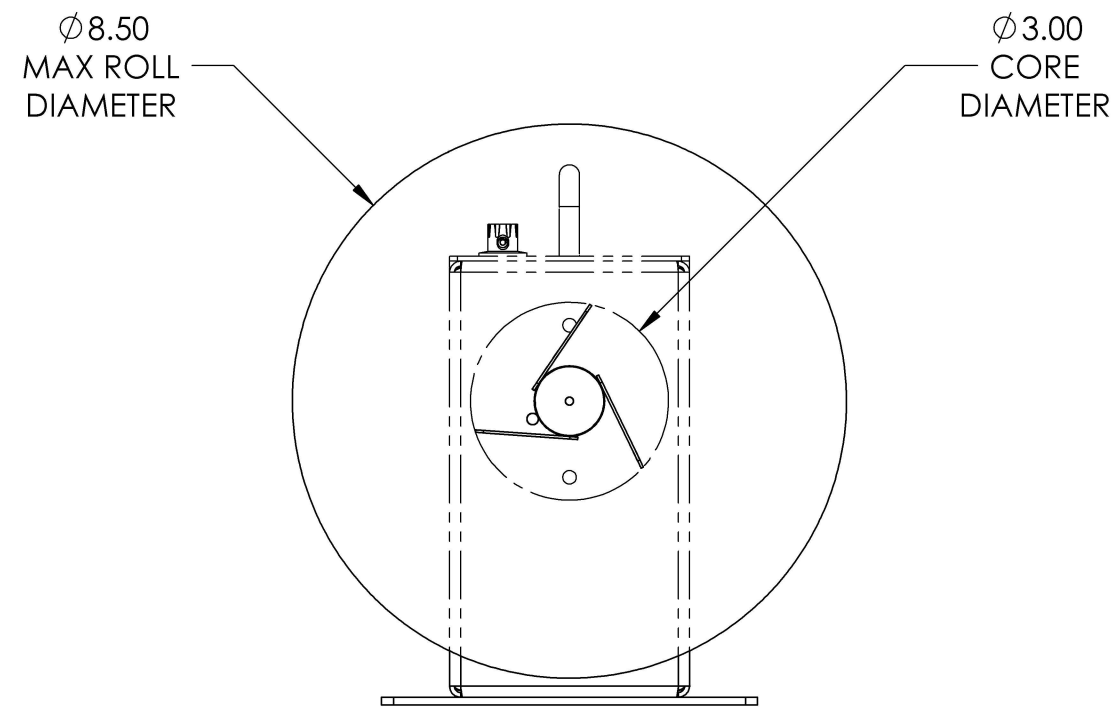

ITEM ID:		
MC-10A		
DRAWN BY:	DATE:	PART NO.
TAH	2/1/2023	80-203-0001
POWER SUPPLY:		INPUT: 100-240VAC 0.6A
PART NO. PS-15	OUTPUT: 15VDC 1.2A	