

LABELMATE USA

LABEL HANDLING INNOVATIONS

CATALOG & PRICELIST

October 2023

Rewinders • Slitters • Dispensers • Applicators • Unwinders
Print Mechanisms • Counters • Core-Chucks • Splicers

About LABELMATE USA

Since 1997 LABELMATE USA has been the World's Leading Manufacturer of desktop label handling products, including Rewinders, Counters, Unwinders, Dispensers, Slitters, Splicers, Applicators and Core Chucks. Today, we are proud to say there are hundreds of thousands of LABELMATE products working perfectly throughout the world.

We are constantly developing new products to meet our customers' requirements. As our business has grown, so has our reputation for providing the most trusted and reliable label handling products in the industry. The LABELMATE name is globally recognized and is synonymous with quality. We welcome any ideas for new products and any comments or suggestions for product improvements. We thank you for your business and will continue to provide you with the world's best desktop Label Handling Innovations!

What's New!

- ◆ [RRC-400](#) Large-Form Reel-to-Reel Label Counter for rolls up to 40 lbs. and 16" in diameter! (pg. 14)
- ◆ [TWIN-MATRIX](#) In-line Matrix Removal System for full-bleed, die-cut color labels! (pg. 18)
- ◆ [UNI-CAT](#) "Smart" Rewinder/Unwinder. The most intelligent Rewinder/Unwinder ever made! (pg.21)
- ◆ [DISTRICOUNT](#) Dispenser/Counter that dispenses and counts quantities of labels on demand! (pg.6)
- ◆ [VERSAMATE-300-OS](#) Label Applicator for applying labels to bags, envelopes and other flat items! (pg. 10)

Warranty / Support / Customize

- ◆ **Support & Service** - We offer FREE lifetime technical support for all of our products worldwide. Call Toll-Free **877.833.7149** or Directly at **+1.702.435.8535**, or email support@labelmateusa.com.
- ◆ **Warranties (Longest in the Industry by far!)**
 - ◆ Rewinders & Unwinders: 5-Year Parts and Labor Limited Warranty.
 - ◆ Counters, Dispensers, Slitters, Reel-to-Reel Count & Rewind Machines, Applicators, Splicing Tables and "Quick-Chucks": 3-Year Parts and Labor Limited Warranty.
 - ◆ Power Supplies, Adaptors, Transformers, Counter Modules, Encoders: 1-Year Parts and Labor Limited Warranty
 - ◆ Print Solutions: Limited warranty provided by AT Information Products.
- ◆ **Customizing/OEM/Private Label** - We do it all! Please contact our sales team and technical development department for questions about your special requirements. Call Toll Free **877.833.7149**, or email sales@labelmateusa.com today!

For questions, comments or requests about any of our products contact us at:

Toll Free: **877.833.7149** Direct: **+1.702.435.8535**

info@labelmateusa.com

© Copyright LABELMATE USA LLC 2000-2023 All rights reserved worldwide.

LABELMATE USA

Label Handling Innovations

Contents

LABEL DISPENSERS.....	3
LABEL APPLICATORS.....	8
LABEL COUNTERS.....	13
MATRIX REMOVAL SYSTEM.....	18
LABEL REWINDERS.....	19
REEL-TO-REEL PRINTERS.....	31
LABEL ROLL SPLICERS.....	32
LABEL UNWINDERS.....	33
LABEL SLITTERS.....	36
CORE-CHUCKS.....	40

LD-100 Label Dispensers

Automatically peel and present labels up to 4.5" wide with the LD-100 Series Label Dispensers.

KEY FEATURES

- Max. Label Width: 4.5" (114-mm)
- Max. Roll Diam.: 8.5" or 12" ¹ (216-mm or 305-mm)
- Core Diam. > 1.5" (38-mm) ²
- High / Low Speeds
 - ◆ Max.: 8 in/sec (200-mm)
 - ◆ Min.: 4 in/sec (100-mm)
- Adjustable sensor for any label length
- "Peel & Present" design:

As soon as a label is removed, the next is immediately advanced
- Weight: 14 - 15 lbs. (6.5-kg) depending on model
- Full 3-Year Parts & Labor Limited Warranty



LD-100-RS-SS



LD-100-U

LABELMATE Label Dispensers peel and present labels one-by-one on demand. As soon as you pick up one label, the next is immediately advanced and presented!

Stainless Steel models are ideal for the food packaging, pharmaceutical and cosmetic industries.

PART NO.	MODEL	LABEL WIDTH	STEEL FINISH	PRICE
----------	-------	-------------	--------------	-------

Opaque Labels

80-147-0001	LD-100-RS	Up to 4.5" (115-mm)	Black Powder-Coat	\$625
80-147-0006	LD-100-RS-SS	Up to 4.5" (115-mm)	Stainless Steel	\$875

Transparent & Opaque Labels

80-147-0003	LD-100-U	Up to 4.5" (115-mm)	Black Powder-Coat	\$795
80-147-0007	LD-100-U-SS	Up to 4.5" (115-mm)	Stainless Steel	\$1,045

1. 12" with addition of LRB-12 option.

2. 1" with addition of SHAFT-1", LD option.

LD-200 Label Dispensers

Automatically peel and present labels up to 6.5" wide with the LD-200 Series Label Dispensers.



KEY FEATURES

- Max. Label Width: 6.5" (165-mm)
- Max. Roll Diam. 8.5" or 12"¹ (216-mm or 305-mm)
- Core Diam. > 1.5" (38-mm)²
- High / Low Speeds
 - ◆ Max.: 8 in/sec (200-mm)
 - ◆ Min.: 4 in/sec (100-mm)
- Adjustable sensor for any label length
- "Peel & Present" design:
 - As soon as a label is removed, the next is immediately advanced
- Weight: 15 - 16 lbs. (7-kg) depending on model
- Full 3-Year Parts & Labor Limited Warranty

Automatic Label Dispensers peel and present labels one-by-one on demand. As soon as you pick up one label, the next is immediately advanced and presented!

Stainless Steel models are ideal for the food packaging, pharmaceutical and cosmetic industries.

PART NO.	MODEL	LABEL WIDTH	STEEL FINISH	PRICE
Opaque Labels				
80-147-0004	LD-200-RS	Up to 6.5" (165-mm)	Black Powder-Coat	\$695
80-147-0008	LD-200-RS-SS	Up to 6.5" (165-mm)	Stainless Steel	\$975
Transparent & Opaque Labels				
80-147-0005	LD-200-U	Up to 6.5" (165-mm)	Black Powder-Coat	\$895
80-147-0009	LD-200-U-SS	Up to 6.5" (165-mm)	Stainless Steel	\$1,145

1. 12" with addition of LRB-12 option.

2. 1" with addition of SHAFT-1", LD option.

LD-300 Label Dispensers

KEY FEATURES

- Labels up to 8.5" wide (216-mm)
- Max. Roll Diam. 8.5" or 12" * (216-mm or 305-mm)
- Core Diam. > 1.5" (38-mm)
- High / Low Speeds
 - ◆ Max.: 8 in/sec (200-mm)
 - ◆ Min.: 4 in/sec (100-mm)
- Adjustable sensor for all label lengths
- Stainless Steel construction: ideal for the food packaging, pharmaceutical and cosmetics industries
- "Peel & Present" design:
As soon as a label is removed, the next is immediately advanced
- Weight: 20 lbs. (9-kg)
- Full 3-Year Parts & Labor Limited Warranty

Automatically peel and present **large labels up to 8.5" wide** with the **LD-300 Series Label Dispensers**.



LD-300-RS-SS

LD-300 Series Label Dispensers are the ideal solution for dispensing **very large labels**.

Automatic Label Dispensers **peel and present labels one-by-one on demand**.

As soon as you pick up one label, the next is **immediately advanced and presented!**

PART NO.	MODEL	LABEL WIDTH	STEEL FINISH	PRICE
Opaque Labels				
80-147-0015	LD-300-RS-SS	Up to 8.5" (218-mm)	Stainless Steel	\$1,175
Transparent & Opaque Labels				
80-147-0016	LD-300-U-SS	Up to 8.5" (218-mm)	Stainless Steel	\$1,245

* 12" with addition of LRB-12 option.

Dispenser-Counter

Precisely **count and dispense** a preset number of labels **without peeling the labels** from the liner.

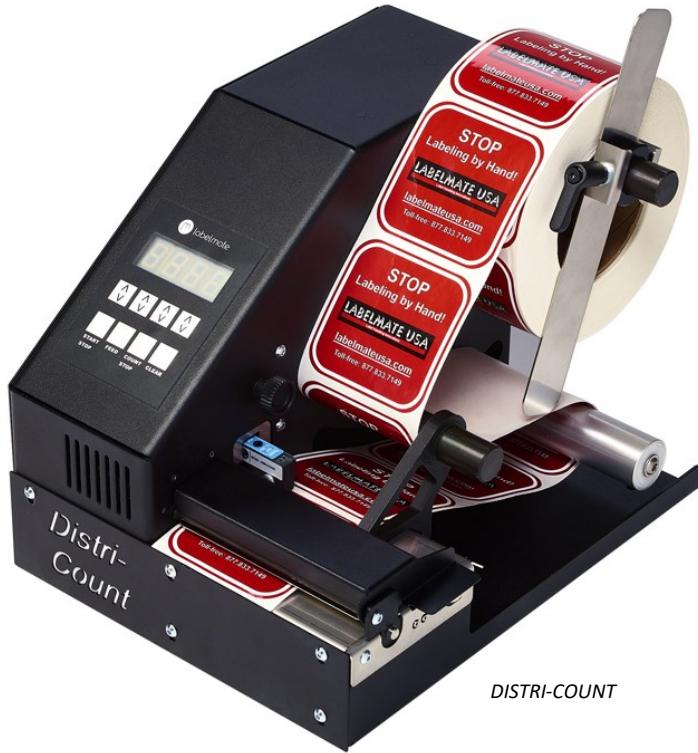

DISTRI-COUNT

DISTRI-COUNT

Unique Label Dispenser/Counter that simultaneously dispenses and counts unpeeled labels on a tear-off bar.

KEY FEATURES

- Softkey control panel & large display
- Easy paper loading with automatic measurement of label size
- Adjustable sensor for various label shapes and sizes
- Integrated web-tension control
- Label Roll Core Diameter > 1" (25-mm)
- Max. Label Roll Diameter: 8.6" (220-mm)
- Max. Label Thickness: 0.08 - 0.17-mm
- Weight: 18 lbs. (8.2-kg)
- Full Limited Warranty
Unit: 3-Year Parts & Labor
Power Adaptor: 1-Year

The softkey control panel and large display make the DISTRI-COUNT **extremely easy to operate**. Once the requested number of labels is dispensed/countered, the DISTRI-COUNT can immediately repeat the action easily and quickly, or be **reprogrammed to dispense and count** a new number of labels.

DISTRI-COUNT

PART NO.	MAX. LABEL WIDTH	MIN. LABEL WIDTH	MAX. LABEL LENGTH	LABEL TYPE	PRICE
50-269-0001	4.5" (115-mm)	0.4" (10-mm)	7.85" (200-mm)	Opaque	\$1,895

Label Dispenser Options

Enhance the versatility of your Label Dispenser with the addition of these **optional upgrades**. *

LRB-12 Extension Bracket



BP-LD Battery Pack



TSN, LD-6 Tensioning Shaft



LDC-1 Label Counter

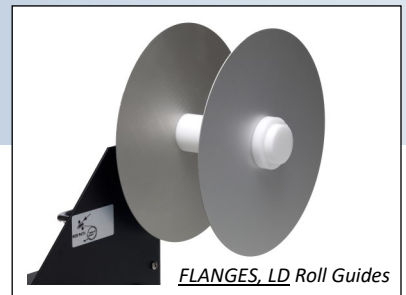

FLANGES, LD Roll Guides

PART NO.	MODEL	DESCRIPTION	PRICE
81-153-0027	FLANGES, LD	Set of two Aluminum Guide Flanges for use with narrow labels. <i>Cannot be used with <u>TSN, LD-6</u>.</i>	\$50
81-119-0001	LRB-12	Extension Bracket for use on LD-100 models. Increases max. roll diameter capacity to 12".	\$50
81-119-0002	LRB-12-SS	Extension Bracket for use on LD-100 Stainless Steel models. Increases max. roll diameter capacity to 12".	\$100
81-141-0017	LDC-1	Digital Counter (Factory Installed). Counts labels as they are dispensed.	\$175
81-244-0006	TSN, LD-6	Tensioning Shaft Assembly for supply roll of labels (3" diameter cores). Provides web tension control.	\$175
80-147-0012	BP-LD	Battery Pack and Charger for mobile label dispensing. 10 - 12 hour battery life.	\$395
81-254-0001	LD-ES	External Start Feature (Factory Installed). Allows an external dispense command to be sent to the Label Dispenser.	\$150
42-213-0008	SHAFT-1", LD	1" diameter Supply Shaft option for LD-100 and LD-200 Label Dispensers. Includes two Guide Rings.	\$50

*Options do not apply to DISTRI-COUNT machines.

Manual Bottle Label Applicator

Manually **apply labels to bottles and other cylindrical objects with a turn of the handle.**

BOTTLEMATE-712M

Manual Bottle Labeler efficiently applies labels to bottles, cans, jars and other cylindrical items.

KEY FEATURES

- **Consistently and accurately apply labels in the same location**
- **Label up to 1,000 bottles per hour**
- **No tools required to adjust for different label sizes.**
- **Max. Label Width: 7" (178-mm)**
- **Max. Bottle Diameter: 10" (255-mm)**
- **Min. Bottle Diameter: 0.3" (7.5-mm)**
- **Label Roll Core Diam. > 0.5" (12-mm)**
- **Weight: 26 lbs. (11.8-kg)**
- **Full 3-Year Parts & Labor Limited Warranty**



BOTTLEMATE-712M

If you are looking for a **simple and versatile solution** for applying labels to bottles, cans, jars or other cylindrical containers but you don't want to spend a fortune, look no further.

The **BOTTLEMATE-712M** is the Applicator you need!

A quick turn of the handle is all that is required to **accurately and consistently** place labels in the same location on all of your cylindrical containers.

BOTTLEMATE-712M

PART NO.	MAX. LABEL WIDTH	MIN. LABEL WIDTH	MAX. ROLL DIAMETER	MAX. BOTTLE DIAMETER	MIN. BOTTLE DIAMETER	PRICE
80-234-0004	7" (178-mm)	0.25" (7-mm)	12" (305-mm)	10" (255-mm)	0.3" (7.5-mm)	\$895

Automatic Bottle Label Applicators

Automatically apply labels to bottles and other cylindrical objects with the *touch of a button*.

BOTTLEMATE-900 Series

Max. Label Width: 9" (230-mm)

BOTTLEMATE-1500 Series

Max. Label Width: 15" (380-mm)

KEY FEATURES

- Automatic Bottle Labeler efficiently applies labels to bottles, cans, jars and other cylindrical items.
- Consistently and accurately apply labels in the same location
- Label up to 1,200 bottles per hour
- Max. Label Roll Diam.: 9" (230-mm)
- Label Roll Core Diam. > 0.5" (12-mm)
- Weight: 26 - 35 lbs. (12 - 16-kg) depending on model
- Available in either 120V or 240V
- Full 3-Year Parts & Labor Limited Warranty



BOTTLEMATE-910P-2

Automatic **BOTTLEMATE** Label Applicators enable you to **quickly and accurately label** all kinds of **cylindrical containers** by simply inserting the container and pressing the footswitch.

PART NO.	MODEL	NO. OF LABELS	MAX. LABEL WIDTH	MIN. LABEL WIDTH	MAX. BOTTLE DIAM.	MIN. BOTTLE DIAM.	PRICE
80-234-0010	BOTTLEMATE -910P	1	9" (228-mm)	0.25" (7-mm)	6" (153-mm)	0.5" (13-mm)	\$1,995
80-234-0011	BOTTLEMATE -910P-2	2	9" (228-mm)	0.25" (7-mm)	6" (153-mm)	0.5" (13-mm)	\$2,345
80-234-0009	BOTTLEMATE -1510P	1	15" (381-mm)	0.25" (7-mm)	6" (153-mm)	0.5" (13-mm)	\$2,195
80-234-0008	BOTTLEMATE -1510P-2	2	15" (381-mm)	0.25" (7-mm)	6" (153-mm)	0.5" (13-mm)	\$2,545

Automatic Flat Item Label Applicator

Automatically apply labels to **bags, pouches, envelopes and other flat items.**



VERSAMATE-300

VERSAMATE-300-OS

Max. Item Width: 11.5" (292-mm)

KEY FEATURES

- Automatic Label Applicator that efficiently applies labels to bags, envelopes and other flat items
- Consistently and accurately apply labels in the same location
- Label items up to 0.20" (5-mm) thick, including slim-line CD/DVD cases
- Label up to 1,200 items per hour
- Max. Label Roll Diam. 9" (230-mm)
- Label Roll Core Diam. > 0.5" (12-mm)
- Weight: 39 lbs. (17.7-kg)
- Available in either 120V or 240V
- Full 3-Year Parts & Labor Limited Warranty

The **VERSAMATE-300-OS** is the optimum desktop solution for automatically **applying labels to flat items.** Simply insert your bag/envelope and watch as **labels are repeatedly applied** in the same location every time.

Labels are applied at more than 4.5" (114-mm) per second. Most items are labeled in less than 3 seconds. Once a rhythm is established, you can **label objects at speeds of up to 1,200 pieces per hour!**

PART NO.	MODEL	MAX. ITEM THICKNESS	MAX. LABEL WIDTH	*MIN. LINER WIDTH	MIN. LABEL LENGTH	PRICE
----------	-------	---------------------	------------------	-------------------	-------------------	-------

Opaque Labels

80-234-0016	VERSAMATE -300-OS	0.20" (5-mm)	11.5" (290-mm)	1.5" (38-mm)	1" (25-mm)	\$3,195
-------------	-------------------	--------------	----------------	--------------	------------	---------

Transparent & Opaque Labels

80-234-0012	VERSAMATE -300	0.20" (5-mm)	11.5" (290-mm)	1.5" (38-mm)	1" (25-mm)	\$3,395
-------------	----------------	--------------	----------------	--------------	------------	---------

*Min. Width applies to **label liner only**. The actual label itself has no minimum width restriction.

Automatic Box Label Applicators

You can now automatically **apply labels to boxes** and other rectangular objects by simply **placing them on a conveyor**.

BOXMATE-610

Max. Box Width: 6" (152-mm)

BOXMATE-612

Max. Box Width: 12" (305-mm)

KEY FEATURES

- **Automatic Box Labeler** efficiently applies labels to boxes and other square and rectangular items.
- **Consistently and accurately** apply labels in the same location
- **Label up to 800 boxes per hour**
- **Max. Label Roll Diam: 9" (230-mm)**
- **Label Roll Core Diam. > 0.5" (12-mm)**
- **Weight: 50 and 59 lbs. (23 and 27-kg)**
- **Available in either 120V or 240V**
- **Full 3-Year Parts & Labor Limited Warranty**



BOXMATE-610

All **BOXMATE** Label Applicators now include an **MC-10A** Rewinder to rewind the waste liner as the labels are applied!



MC-10A

PART NO.	MODEL	MAX. BOX WIDTH	*MAX. BOX HEIGHT	MAX. BOX LENGTH	LABEL TYPE	NO. OF LABELS	PRICE
80-234-0014	BOXMATE-610	6" (153-mm)	4.5" (115-mm)	25" (635-mm)	Opaque	1	\$3,995
80-234-0013	BOXMATE-612	12" (305-mm)	4.5" (115-mm)	25" (635-mm)	Opaque	1	\$4,250

*Max box height only applies when using the hold-down roller. Roller can be removed for unlimited box height.

Label Applicator Options

Enhance the versatility of your Label Applicator with the addition of these **optional upgrades**.



Options are available for **Automatic Label Applicators** only, and are factory installed at time of order.

PART NO.	MODEL	DESCRIPTION	PRICE
50-234-0006	AUTO-MATE	Sensor that automatically activates the unit without use of the Footswitch. For BOTTLEMATE units only.	\$150
50-234-0005	BMR-6	Waste Rewinder for BOTTLEMATE Label Applicators. <i>Cannot be used concurrently with BMC-1.</i>	\$450
80-203-0001	MC-10A	Independent Waste Rewinder for BOXMATE Applicators. May be added at any time.	\$495
81-141-0005	BMC-1	Digital Label Counter for BOTTLEMATE and VERSAMATE Applicators. <i>Cannot be used concurrently with BMR-6.</i>	\$150

RRC-330 Reel-to-Reel Counters

Reel-to-Reel Counters **verify the number of labels on a roll**. Standard models count opaque labels, and Ultrasonic models count opaque and transparent labels.

STANDARD

Opaque labels only

ULTRASONIC

Transparent & Opaque labels

KEY FEATURES

- **Accurate & repeatable label counts**
- **Adjustable tension control**
- **6-Digit Counter with auto preset stop capability**
- **Rewind clockwise or counterclockwise**
- **Variable speed control**
- **Max. Speed: 108 in/sec* (2,743-mm)**
- **Max. Roll Weight: 17 lbs. (7.7-kg)**
- **Weight: 40 lbs. (18-kg)**
- **Full 3-Year Parts & Labor Limited Warranty**



RRC-330-AU



RRC-330

Switch-selectable **optical or ultrasonic counting mode** is now included on all Ultrasonic Counters!

PART NO.	MODEL	UNWIND CORE	REWIND CORE	MAX. ROLL DIAMETER	MAX. LABEL WIDTH	PRICE
----------	-------	-------------	-------------	--------------------	------------------	-------

Opaque Labels (Standard)

80-238-0004	RRC-330	3" (76-mm)	3" (76-mm)	13" (330-mm)	6" (115-mm)	\$2,195
80-238-0005	RRC-330-A	3" (76-mm)	1 – 4" (25 –100-mm)	12.5" (317-mm)	6" (115-mm)	\$2,395

Transparent & Opaque Labels (Ultrasonic)

80-238-0007	RRC-330-U	3" (76-mm)	3" (76-mm)	13" (330-mm)	6" (115-mm)	\$3,895
80-238-0006	RRC-330-AU	3" (76-mm)	1 – 4" (25 –100-mm)	12.5" (317-mm)	6" (115-mm)	\$4,195

*Linear speed varies based upon roll diameter and weight.

RRC-400 Reel-to-Reel Counters

Large-Form Reel-to-Reel Counters verify the number of labels on a roll, and can handle rolls up to 16" in diameter, and that weigh up to 40 lbs.



RRC-400-U, with
RR-C76-170 (x2)

RRC-400

Opaque labels only

RRC-400-U

Transparent & Opaque labels

KEY FEATURES

- Accurate & repeatable label counts
- Adjustable tension control
- 6-Digit Counter with auto preset stop capability
- Bi-directional rewind capability
- Variable speed control, w/ "SYNC" mode for optimum speed and tension
- Max. Speed: 527 in/sec* (13,385-mm)
- Max. Roll Weight: 40 lbs. (18-kg)
- Weight: 64 lbs. (29-kg)
- Full 3-Year Parts & Labor Limited Warranty

Select the model that best suits your label type, and then add two Core-Holders.

The RRC-ENC Encoder Option can be added to count/measure gapless labels or continuous media.

Counter Model

PART NO.	MODEL	MAX. ROLL DIAMETER	PRICE
----------	-------	--------------------	-------

Opaque Labels

80-238-0013	RRC-400	16" (406-mm)	\$3,605
-------------	---------	-----------------	---------

Transparent & Opaque Labels

80-238-0014	RRC-400-U	16" (406-mm)	\$4,605
-------------	-----------	-----------------	---------

Core-Holders (Select 2)

PART NO.	CORE HOLDER	DESCRIPTION	CORE DIAM.	MAX. LABEL WIDTH	PRICE
81-197-0020	RR-C76-170	Core-Chuck	3"	6"	\$595
81-197-0021	RR-C76-220	Core-Chuck	3"	8"	\$645
81-246-0005	ACH-RR-400	Adjustable	1" - 4"	6"	\$695

*Linear speed varies based upon roll diameter and weight.

RRC-330 Reel-to-Reel Counter Options

Enhance the versatility of your Reel-to-Reel Counter with the addition of these **optional upgrades**.

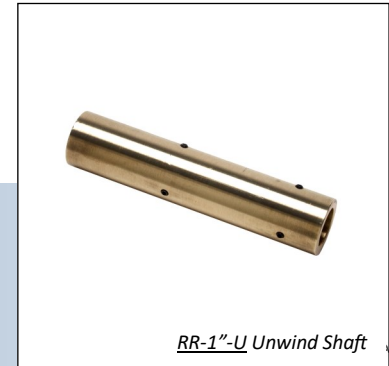

PART NO.	MODEL	DESCRIPTION	PRICE
41-213-0020	RR-1"-U	Unwind Shaft for 1" diameter cores.	\$125
41-213-0021	RR-1.5"-U	Unwind Shaft for 1.5" diameter cores.	\$175
81-141-0006	RRC-ENC	Encoder. Factory-installed option that allows for linear measurement & counting labels with no gaps in between. <i>For use on Standard RRC models only.</i>	\$1,595
81-205-0026	ROLLER KIT, RR-8	8" Roller Kit Upgrade. Enables the unit to count labels up to 8" wide.	\$250
81-205-0025	ROLLER KIT, RR-10	10" Roller Kit Upgrade. Enables the unit to count labels up to 10" wide.	\$295
81-151-0002	FIN SET, 96MM	Set of three (3) steel Fins plus hardware for unwind Shaft. Enables the unwind shaft to handle 6" diameter cores.	\$65

Non-Motorized Counters

Pair a **Non-Motorized Counter** with a Rewinder to **count labels "in-line"** directly as they exit the printer.



STANDARD

Opaque labels only

ULTRASONIC

Transparent & Opaque labels

KEY FEATURES

- **Accurate & repeatable label counts**
- **6-Digit Counter with auto preset stop capability when used with Rewinder and External Halt Cable**
- **Use together with a Rewinder to perform "in-line" counting**
- **Weight: 14-16 lbs. (7-kg) depending on model**
- **Full 3-Year Parts & Labor Limited Warranty**

Easily **maintain an accurate count** of the number of labels printed or used by passing them through a Non-Motorized Counter **as they are rewound**.

PART NO.	MODEL	MAX. LABEL WIDTH	MIN. LABEL WIDTH	GAPS REQUIRED BETWEEN LABELS	PRICE
----------	-------	------------------	------------------	------------------------------	-------

Opaque Labels (Standard)

80-238-0001	C-100	6" (152-mm)	0.5" (12.5-mm)	Yes	\$795
80-238-0002	C-200	10" (254-mm)	0.5" (12.5-mm)	Yes	\$895

Transparent & Opaque Labels (Ultrasonic)

80-238-0011	C-100-US	6" (152-mm)	0.5" (12.5-mm)	Yes	\$1,795
80-238-0012	C-200-US	10" (254-mm)	0.5" (12.5-mm)	Yes	\$1,895

Label Counting Packages

Label Counting Packages allow you to easily and accurately count large rolls of labels.

STANDARD

Opaque Labels only

ULTRASONIC

Transparent & Opaque labels

KEY FEATURES

- *Three-piece system with Powered CAT-3-CHUCK Rewinder/Unwinders*
- *Non-Motorized Counter with 6-Digit LED Display*
- *Bi-Directional winding*
- *Variable speed control*
- *Max. Speed: 240 in/sec (6,096-mm)**
- *Max. Roll Weight: 20 lbs. (9-kg)*
- *Weight: 73 - 77 lbs. (33 - 35-kg) depending on model*
- *Full Limited Warranty:
Rewinders: 5-Years
Counter: 3-Years*



COUNT-200-DELUXE-US

PART NO.	MODEL	CORE DIAMETER	MAX. LABEL WIDTH	MIN. LABEL WIDTH	MAX. ROLL DIAMETER	PRICE
----------	-------	---------------	------------------	------------------	--------------------	-------

Opaque Labels (Standard)

80-266-0001	COUNT-100-DELUXE	3" (76-mm)	6" (153-mm)	0.5" (12.5-mm)	12" (305-mm)	\$2,995
80-266-0002	COUNT-200-DELUXE	3" (76-mm)	10" (254-mm)	0.5" (12.5-mm)	12" (305-mm)	\$3,295

Transparent & Opaque Labels (Ultrasonic)

80-266-0003	COUNT-100-DELUXE-US	3" (76-mm)	6" (153-mm)	0.5" (12.5-mm)	12" (305-mm)	\$3,995
80-266-0004	COUNT-200-DELUXE-US	3" (76-mm)	10" (254-mm)	0.5" (12.5-mm)	12" (305-mm)	\$4,295

Options for Label Counting Packages

70-171-0001	UPG, PKG-16	Upgrade any Count Package to 16" diameter roll capacity.	\$400
-------------	-------------	--	-------

*Linear speed varies based upon roll diameter and weight.

Matrix Removal System

The **Matrix Removal System** is ideal for in-line rewinding and matrix removal of **full-bleed, die-cut color printed labels**.

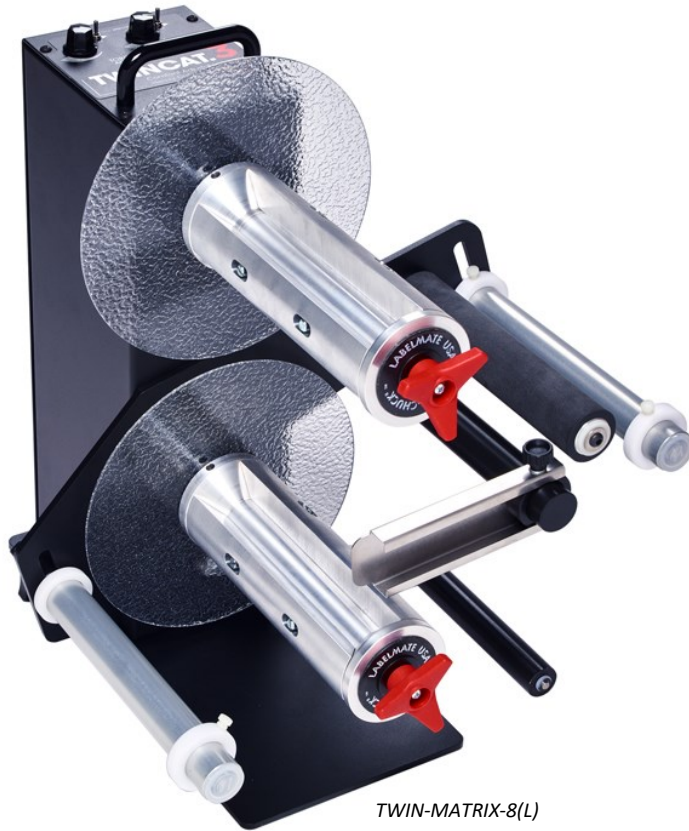

TWIN-MATRIX-8(L)

KEY FEATURES

- *Customize the unit with two core-holders of your choice*
- *Sensor Arm starts and stops the unit together with the printer*
- *Speed of the unit automatically matches the printer*
- *Independent direction & speed control of each core-holder (switch-selectable)*
- *Variable speed control*
- *Gearless motors that can simultaneously be set to wind in opposite directions*
- *Max. Speed: 170 in/sec (4,318-mm)*
- *Max. Roll Weight: 15 lbs. (6.8-kg)*
- *Weight: 48 - 53 lbs. (22 - 24-kg) depending on core-holders selected*
- *Full 5-Year Parts & Labor Limited Warranty*

Machine Orientation (Left or Right) for use with the printer is specified at the time of order.



PART NO.	MODEL	CORE HOLDER	CORE DIAM.	MAX. LABEL WIDTH	MAX. ROLL DIAM.	PRICE
80-271-0003	TWIN-MATRIX-6	Mechanical Chuck	3" (76-mm)	6" (152-mm)	8.5" (215-mm)	\$2,995
80-271-0005	TWIN-MATRIX-8	Mechanical Chuck	3" (76-mm)	8" (203-mm)	8.5" (215-mm)	\$3,195
80-271-0007	TWIN-MATRIX-10	Mechanical Chuck	3" (76-mm)	10" (254-mm)	8.5" (215-mm)	\$3,395





Label Rewinders

CHOOSING YOUR REWINDER

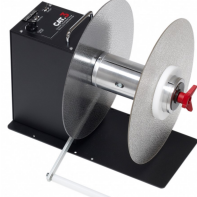
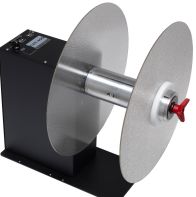
With over 50 different possible configurations, LABELMATE USA has a Rewinder for virtually every application.

The following is an overview of the different categories and main features:

				
	Pg. 20	Pg. 21	Pg. 24	Pg. 25
MODEL	<u>MINI-CAT</u>	<u>CAT-3</u>	<u>CAT-3SA</u>	<u>CAT-40G</u>
FOR PRINTER TYPE	DESKTOP & MIDRANGE LOW-SPEED	INDUSTRIAL & MIDRANGE HIGH-SPEED	COLOR & INDUSTRIAL	SPECIALTY
MAX. LABEL WIDTH	4.5" (114-mm)	6" - 10" (152 - 254-mm)	6" - 10" (152 - 254-mm)	6" - 10" (152 - 254-mm)
MAX. ROLL DIAMETER	8.6" (220mm)	12" (305-mm)	12" (305-mm)	16" (405-mm)
MAX. SPEED*	102 in/sec (2590 mm/s)	240 in/sec (6096 mm/s)	120 in/sec (3048 mm/s)	320 in/sec (8128 mm/s)
NOTES	The small, versatile desktop champ!	Fast, heavy-duty desktop solution	Heavy-duty desktop solution w/ Sensor Arm	Gear-driven High-Torque Power

				
	Pg. 27	Pg. 23	Pg. 29	Pg. 28
MODEL	<u>ZCAT</u>	<u>UNI-CAT</u>	<u>TWIN-CAT</u>	<u>RRR</u>
FOR PRINTER TYPE	COLOR, HIGH RESOLUTION & RFID	COLOR & INDUSTRIAL	SPECIALTY	N/A
MAX. LABEL WIDTH	6" - 10" (152 - 254-mm)	6" - 10" (152 - 254-mm)	6" - 10" (152 - 254-mm)	6" - 10" (152 - 254-mm)
MAX. ROLL DIAMETER	12" (305-mm)	12" (305-mm)	8.6" (220mm)	13" (330-mm)
MAX. SPEED*	35 in/sec (890 mm/s)	120 in/sec (3048 mm/s)	170 in/sec (4318 mm/s)	108 in/sec (2743 mm/s)
NOTES	Tensioning solution for delicate inkjet printers	Universal "smart" Winder w/ Sensor Arm	Dual-Spindle Rewind/Unwind Station	Reel-to-Reel "off-line" Rewinder

*Linear speed varies based upon roll diameter and weight.

MINI-CAT Rewinders

Use these **agile, durable and compact** Rewinders with virtually any printer on the market today.

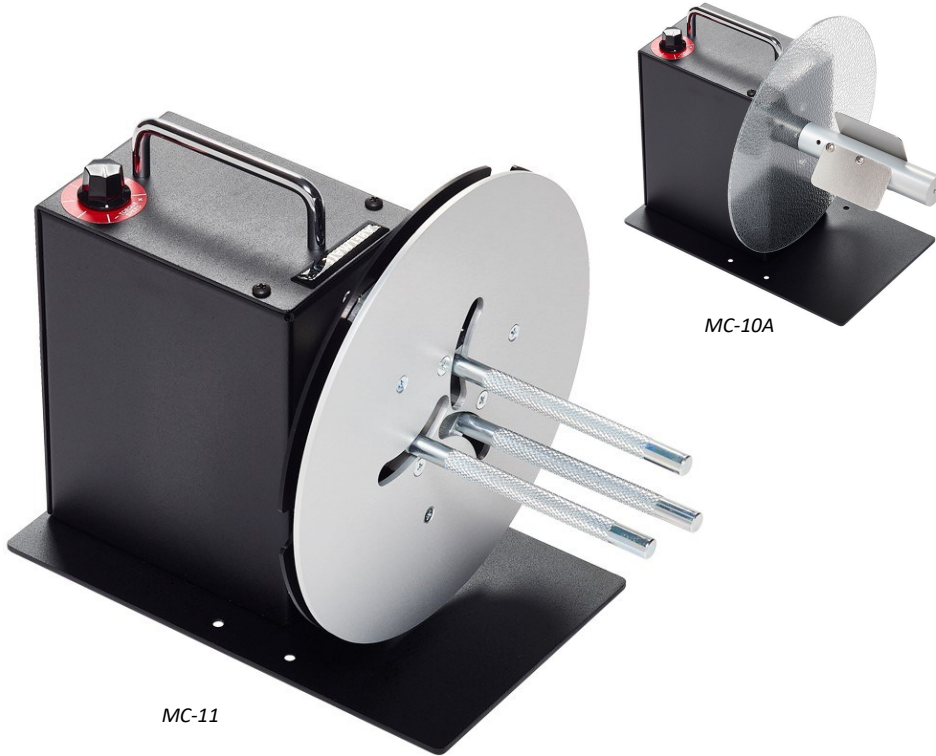

MC-10A

3" (76-mm)
Diameter Core-Holder

MC-11

Adjustable 1" - 4" (25-101mm)
Diameter Core-Holder

KEY FEATURES

- Gearless motor that can be stalled indefinitely without any harm
- Silent operation
- Adjustable speed control
- Max. Speed: 102 in/sec (2,590-mm)*
- Max. Roll Weight: 12 lbs. (6-kg)
- Weight: 14 - 16 lbs. (6.4 - 7-kg) depending on model.
- Bi-directional rewind capability (switch-selectable)
- Full 5-Year Parts & Labor Limited Warranty

Reliable, smooth and virtually silent in operation, Mini-CAT Rewinders provide a simple and reliable rewind solution, and are designed for continuous 24/7 service.

PART NO.	MODEL	CORE DIAMETER	MAX. LABEL WIDTH	MAX. ROLL DIAMETER	PRICE
80-203-0001	MC-10A	3" (76-mm)	4.5" (114-mm)	8.6" (220-mm)	\$495
80-203-0002	MC-11	1" - 4" (25 - 101-mm)	4.5" (114-mm)	8.6" (220-mm)	\$595

Options for MINI-CAT Rewinders

81-153-0023	FLANGE, OUT-MC	Outer Guide Flange for use with <u>MC-10A</u> . Assists in maintaining an even roll edge.	\$50
81-102-0002	APG-MC	Adjustable Paper Guide for use with <u>MC-10A</u> or <u>MC-11</u> . Assists in maintaining an even roll edge.	\$50

*Linear speed varies based upon roll diameter and weight.

CAT-3 Rewinders (12")

CAT-3 Rewinders provide a powerful, **heavy-duty** and **reliable solution** for rewinding virtually any material.

KEY FEATURES

- Gearless motor that can be stalled indefinitely without any harm
- Constant Adjustable Torque (CAT)®
- Silent operation
- Adjustable speed control
- Designed for continuous 24/7 use
- Includes 2 Guide Flanges
- Max. Speed: 240 in/sec (6,096-mm)*
- Max. Roll Weight: 20 lbs. (9-kg)
- Weight: 26 - 31 lbs. (11.8 - 14-kg) depending on model
- Bi-directional rewind capability (switch-selectable)
- Full 5-Year Parts & Labor Limited Warranty



CAT-3-CHUCK-220

PART NO.	MODEL	CORE HOLDER	CORE DIAM.	MAX. LABEL WIDTH	MAX. ROLL DIAM.	PRICE
80-203-0009	CAT-3 -CORELESS	Coreless	-	6" (152-mm)	12" (305-mm)	\$895
80-203-0004	CAT-3-1-INCH	Fin-Style (1")	1" (25-mm)	6" (152-mm)	12" (305-mm)	\$895
80-203-0005	CAT-3-ACH	Adjustable	1" - 4" (25 - 101-mm)	6" (152-mm)	11" (280-mm)	\$1,125
80-203-0035	CAT-3 -STANDARD	Fin-Style (3")	3" (76-mm)	6" (152-mm)	12" (305-mm)	\$895
80-203-0006	CAT-3-CHUCK	Mechanical Chuck	3" (76-mm)	6" (152-mm)	12" (305-mm)	\$1,075
80-203-0008	CAT-3- CHUCK-220	Mechanical Chuck	3" (76-mm)	8" (203-mm)	12" (305-mm)	\$1,135
80-203-0007	CAT-3 -CHUCK-10	Mechanical Chuck	3" (76-mm)	10" (254-mm)	12" (305-mm)	\$1,195
80-203-0036	CAT-3-W10	Fin-Style	3" (76-mm)	10" (254-mm)	12" (305-mm)	\$995

*Linear speed varies based upon roll diameter and weight.

CAT-3 Rewinders (16" & 18")

Use these large, *high-powered Rewinders* to handle media rolls *up to 18" in diameter*.

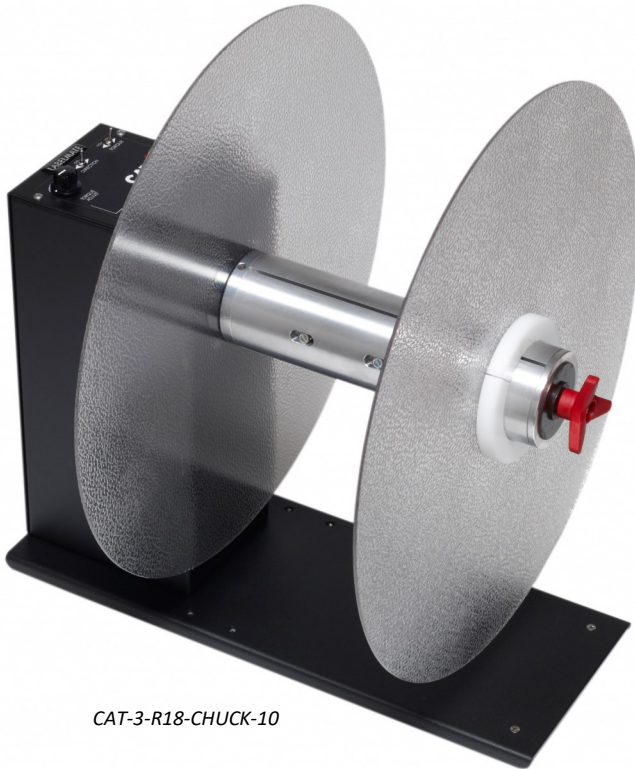

CAT-3-R18-CHUCK-10

KEY FEATURES

- Gearless motor that can be stalled indefinitely without any harm
- Constant Adjustable Torque (CAT)[®]
- Silent operation
- Adjustable speed control
- Designed for continuous 24/7 use
- Includes 2 Guide Flanges
- Includes High-Torque option
- Max. Speed: 360 in/sec (9,144-mm)*
- Max. Roll Weight: 20 lbs. (9-kg)
- Weight: 31 - 36 lbs. (14 - 16.3-kg) depending on model
- Bi-directional rewind capability (switch-selectable)
- Full 5-Year Parts & Labor Limited Warranty

PART NO.	MODEL	CORE HOLDER	CORE DIAM.	MAX. LABEL WIDTH	MAX. ROLL DIAM.	PRICE
----------	-------	-------------	------------	------------------	-----------------	-------

16" Roll Diameter

80-203-0020	CAT-3-R16-CHUCK	Mechanical Chuck	3" (76-mm)	6" (152-mm)	16" (406-mm)	\$1,295
80-203-0022	CAT-3-R16-CHUCK-220	Mechanical Chuck	3" (76-mm)	8" (203-mm)	16" (406-mm)	\$1,350
80-203-0021	CAT-3-R16-CHUCK-10	Mechanical Chuck	3" (76-mm)	10" (254-mm)	16" (406-mm)	\$1,395

18" Roll Diameter

80-203-0023	CAT-3-R18-CHUCK	Mechanical Chuck	3" (76-mm)	6" (152-mm)	18" (457-mm)	\$1,550
80-203-0025	CAT-3-R18-CHUCK-220	Mechanical Chuck	3" (76-mm)	8" (203-mm)	18" (457-mm)	\$1,605
80-203-0024	CAT-3-R18-CHUCK-10	Mechanical Chuck	3" (76-mm)	10" (254-mm)	18" (457-mm)	\$1,695

*Linear speed varies based upon roll diameter and weight.

Intelligent UNI-CAT Rewinders

Intelligent combination Rewinder / Unwinder. The most "UNI-VERSATILE" Winder in our product line!

KEY FEATURES

- *Ideal companion for color inkjet printers*
- *"Smart" responsive direction control: self-teaching to function as either a Rewinder OR an Unwinder*
- *Supports back-feed process for color inkjet and tension-sensitive printers*
- *Automatic speed adjustment to align with print speed*
- *Maintenance-free soft-touch control panel with LED status indicators*
- *Bi-directional for internal and external winding*
- *Automatically stops at end of roll*
- *Max. Speed: 50 in/sec* (1,270-mm)*
- *Max. Roll Weight: 20 lbs. (9-kg)*
- *Weight: 31 - 34 lbs. (14 - 15.4-kg) depending on model*
- *Full 5-Year Parts & Labor Limited Warranty*



UNI-CAT-CHUCK

PART NO.	MODEL	CORE HOLDER	CORE DIAM.	MAX. LABEL WIDTH	MAX. ROLL DIAM.	PRICE
80-203-0089	UNI-CAT -1-INCH	Fin-Style (1")	1" (25-mm)	6" (152-mm)	12" (305-mm)	\$1,095
80-203-0088	UNI-CAT-ACH	Adjustable	1" - 4" (25 - 101-mm)	6" (152-mm)	11" (280-mm)	\$1,350
80-203-0086	UNI-CAT -STANDARD	Fin-Style (3")	3" (76-mm)	6" (152-mm)	12" (305-mm)	\$1,125
80-203-0083	UNI-CAT -CHUCK	Mechanical Chuck	3" (76-mm)	6" (152-mm)	12" (305-mm)	\$1,300
80-203-0084	UNI-CAT -CHUCK-220	Mechanical Chuck	3" (76-mm)	8" (203-mm)	12" (305-mm)	\$1,360
80-203-0085	UNI-CAT -CHUCK-10	Mechanical Chuck	3" (76-mm)	10" (254-mm)	12" (305-mm)	\$1,420
80-203-0087	UNI-CAT-W10	Fin-Style	3" (76-mm)	10" (254-mm)	12" (305-mm)	\$1,195

*Linear speed varies based upon roll diameter and weight.

CAT-3SA Rewinders

These Rewinders **start and stop automatically** with the printer through use of a **special Sensor Arm** that tracks the labels.



CAT-3SA-CHUCK

KEY FEATURES

- Sensor Arm automatically starts and stops the Rewinder w/ the Printer
- Constant Adjustable Torque (CAT)[®]
- Silent in operation
- Adjustable speed control
- Includes 2 Guide Flanges
- Max. Speed: 120 in/sec (3,048-mm)
- Max. Roll Weight: 20 lbs. (9-kg)
- Weight: 29 - 33 lbs. (13 - 15-kg) depending on model
- Bi-directional rewind capability (switch-selectable)
- Full 5-Year Parts & Labor Limited Warranty

PART NO.	MODEL	CORE HOLDER	CORE DIAM.	MAX. LABEL WIDTH	MAX. ROLL DIAM.	PRICE
80-203-0031	CAT-3SA -CORELESS	Coreless	-	6" (152-mm)	12" (305-mm)	\$995
80-203-0026	CAT-3SA -1-INCH	Fin-Style (1")	1" (25-mm)	6" (152-mm)	12" (305-mm)	\$995
80-203-0027	CAT-3SA-ACH	Adjustable	1" - 4" (25 - 101-mm)	6" (152-mm)	11" (280-mm)	\$1,250
80-203-0033	CAT-3SA -STANDARD	Fin-Style (3")	3" (76-mm)	6" (152-mm)	12" (305-mm)	\$995
80-203-0028	CAT-3SA -CHUCK	Mechanical Chuck	3" (76-mm)	6" (152-mm)	12" (305-mm)	\$1,200
80-203-0030	CAT-3SA -CHUCK-220	Mechanical Chuck	3" (76-mm)	8" (203-mm)	12" (305-mm)	\$1,260
80-203-0029	CAT-3SA -CHUCK-10	Mechanical Chuck	3" (76-mm)	10" (254-mm)	12" (305-mm)	\$1,320
80-203-0034	CAT-3SA-W10	Fin-Style	3" (76-mm)	10" (254-mm)	12" (305-mm)	\$1,050
80-203-0032	CAT-3SA -R16-CHUCK	Mechanical Chuck	3" (76-mm)	6" (152-mm)	16" (406-mm)	\$1,400

*Linear speed varies based upon roll diameter and weight.

CAT-40G Rewinders

Super High Torque Gear-Driven Rewinders that provide an amplified solution for very heavy rolls.

KEY FEATURES

- Gear-Driven High-Torque Rewinder
- Two versions available:
Standard & Sensor Arm
- Adjustable speed control
- Designed for continuous 24/7 use
- Includes 2 Guide Flanges
- Max. Speed: *
320 in/sec (8,128-mm) - Standard
160 in/sec (4,064-mm) - Sensor Arm
- Max. Roll Weight: 50 lbs. (22-kg)
- Weight: 34 - 39 lbs. (15 - 18-kg)
depending on model
- Bi-directional rewind capability
(switch-selectable)
- Full 5-Year Parts & Labor
Limited Warranty

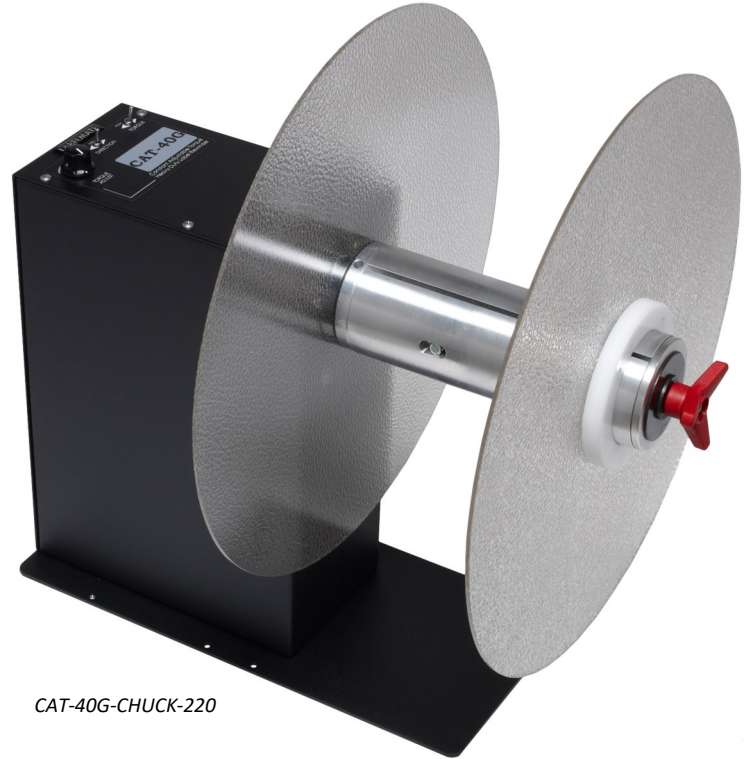

CAT-40G-CHUCK-220

PART NO.	MODEL	CORE HOLDER	CORE DIAM.	MAX. LABEL WIDTH	MAX. ROLL DIAM.	PRICE
----------	-------	-------------	------------	------------------	-----------------	-------

High Torque

80-203-0037	CAT-40G	Mechanical Chuck	3" (76-mm)	6" (152-mm)	16" (406-mm)	\$1,595
80-203-0039	CAT-40G-220	Mechanical Chuck	3" (76-mm)	8" (203-mm)	16" (406-mm)	\$1,655
80-203-0038	CAT-40G-10	Mechanical Chuck	3" (76-mm)	10" (254-mm)	16" (406-mm)	\$1,695

High Torque w/ Sensor Arm

80-203-0040	CAT-40G-SA	Mechanical Chuck & Sensor Arm	3" (76-mm)	6" (152-mm)	16" (406-mm)	\$1,695
80-203-0042	CAT-40G -SA-220	Mechanical Chuck & Sensor Arm	3" (76-mm)	8" (203-mm)	16" (406-mm)	\$1,755
80-203-0041	CAT-40G -SA-10	Mechanical Chuck & Sensor Arm	3" (76-mm)	10" (254-mm)	16" (406-mm)	\$1,795

*Linear speed varies based upon roll diameter and weight.

CAT-3 Rewinder Options

Enhance the versatility of your CAT-3 Label Rewinder with the addition of these **optional upgrades**.

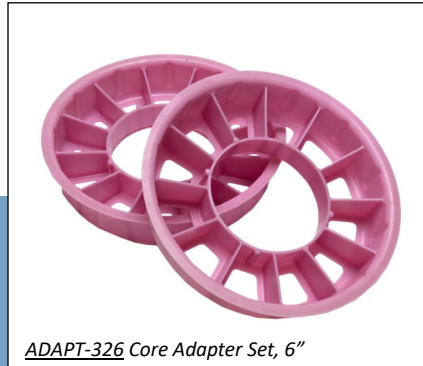

PART NO.	MODEL	DESCRIPTION	PRICE
10-155-0001	FOOTSWITCH	Pedal that starts or stops the Rewinder when pressed and held.	\$100
81-101-0001	ADAPT-326	Set of Core Adapters for 6" diameter Cores. Can be used only on Rewinders with a "Quick-Chuck" Core Holder.	\$30
81-253-0001	BURST-180-DELUXE	Burster Bar Assembly attaches to Rewinder to burst apart perforated tags or labels. <i>Requires HTO-CAT option.</i>	\$375
81-250-0001	HTO-CAT	High-Torque Option. Increases maximum torque 25% and doubles maximum speed. Factory-installed only.	\$150
81-250-0002	LTO-CAT	Low-Torque Option. Creates a low torque range below standard threshold. Factory-installed only.	\$150
81-102-0001	APG-CAT	Adjustable Paper Guide, used primarily with the CAT-3-ACH Rewinder. Maintains flush outer roll edge.	\$65

ZCAT Rewinders

KEY FEATURES

- *Eliminates ALL tension on printer!*
- *Eliminates ALL print registration issues!*
- *Factory quality finish-rolls with fully adjustable tension control*
- *Optical Sensor starts/stops rewriter in unison with printer*
- *Bi-directional rewind capability*
- *Desired Rewind Orientation (Left or Right) is specified at time of purchase*
- *Max. Speed: 50 in/sec (1,270-mm)*
- *Max. Roll Weight: 20 lbs. (9-kg)*
- *Weight: 51 - 54 lbs. (23 - 25-kg) depending on model*
- *Full 5-Year Parts & Labor Limited Warranty*

Tensioning Rewinder, ideal for use with delicate color inkjet printers. Yields factory quality finish-rolls!



ZCAT-8
LEFT Orientation shown

*All ZCAT Rewinders are built-to-order for use on either the **Left** or **Right** side of your printer. Specify desired orientation (Left or Right) at time of purchase.*

PART NO.	MODEL	CORE HOLDER	CORE DIAM.	MAX. LABEL WIDTH	MAX. ROLL DIAM.	PRICE
80-203-0080	ZCAT-6	Mechanical Chuck	3" (76-mm)	6" (152-mm)	12" (305-mm)	\$1,495
80-203-0081	ZCAT-8	Mechanical Chuck	3" (76-mm)	8" (203-mm)	12" (305-mm)	\$1,595
80-203-0093	ZCAT-10	Mechanical Chuck	3" (76-mm)	10" (254-mm)	12" (305-mm)	\$1,695

Options for ZCAT Rewinders

81-141-0015	PCZ-1	Digital Preset Counter (factory installed). Only for opaque labels with a gap.	\$395
81-153-0015	FLANGE, OUT, QC-12	Outer Guide Flange for 3" diameter "Quick-Chuck" Core Holder. 12" diameter capacity.	\$55

*Linear speed varies based upon roll diameter and weight.

Reel-to-Reel Rewinders

Use our *Reel-to-Reel Rewinders* to rewind, reverse roll facing, and re-tension your label rolls.



RRR-330-A



RRR-330

RRR-330

**3" to 3" Core Diameter
(76 - 76mm)**

RRR-330-A

**3" to 1"-4" Core Diameter
(76 - 25-100mm)**

KEY FEATURES

- *Reverse wind direction*
- *Wind-in or wind-out*
- *Adjustable tension control*
- *Rewind clockwise or counterclockwise*
- *Variable speed control*
- *Max. Speed: 108 in/sec*
(2,743-mm)*
- *Max. Roll Weight:
17 lbs. (7.7-kg)*
- *Weight: 34 lbs. (15.4-kg)*
- *Full 3-Year Parts & Labor
Limited Warranty*

PART NO.	MODEL	UNWIND CORE	REWIND CORE	MAX. ROLL DIAMETER	MAX. LABEL WIDTH	PRICE
80-203-0049	RRR-330	3" (76-mm)	3" (76-mm)	13" (330-mm)	6" (115-mm)	\$1,795
80-203-0050	RRR-330-A	3" (76-mm)	1 - 4" (25 - 100-mm)	12.5" (317-mm)	6" (115-mm)	\$1,995

Options for Reel-to-Reel Rewinders

81-205-0026	ROLLER KIT, RR-8	8" Roller Kit Upgrade. Enables the unit to count labels up to 8" wide.				\$250
81-205-0025	ROLLER KIT, RR-10	10" Roller Kit Upgrade. Enables the unit to count labels up to 10" wide.				\$295
81-151-0002	FIN SET, 96MM	Set of three (3) steel Fins plus hardware for unwind Shaft. Enables the unwind shaft to handle 6" diameter cores.				\$65
41-213-0020	RR-1"-U	Unwind Shaft for 1" diameter cores.				\$125
41-213-0021	RR-1.5"-U	Unwind Shaft for 1.5" diameter cores.				\$175

*Linear speed varies based upon roll diameter and weight.

TWIN-CAT-3 Rewind Station

KEY FEATURES

- *Customize the Rewind Station with two core-holders of your choice*
- *Rewinder, core-holders, and desired options each purchased separately*
- *Independent direction & speed control of each core-holder (switch-selectable)*
- *Strip unwanted matrix from die-cut labels*
- *Gearless motors that can simultaneously be set to wind in opposite directions*
- *Max. Speed: 170 in/sec (4,318-mm)*
- *Max. Roll Weight: 15 lbs. (6.8-kg)*
- *Weight: 45 - 50 lbs. (20 - 23-kg) depending on core-holders selected*
- *Full 5-Year Parts & Labor Limited Warranty*

Dual-Spindle Rewind Station that provides an easy solution for wind-in/wind-out, label reversing & inspection applications.

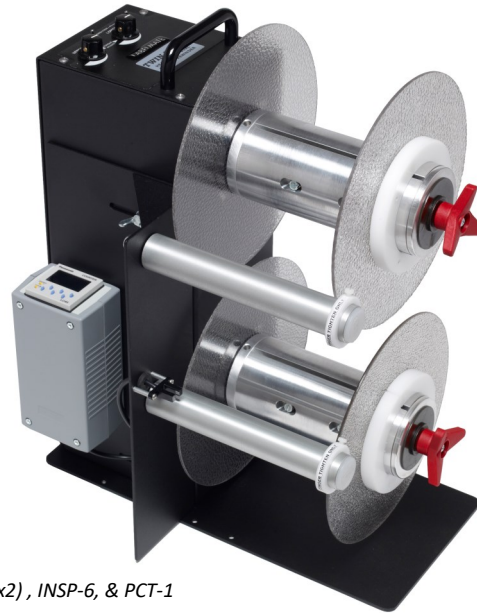

TWIN-CAT-3

Shown with:
TC-C76-170 (x2), INSP-6, & PCT-1

80-203-0043	TWIN-CAT-3 (Drive Tower Only)					\$1,395
PART NO.	CORE HOLDER	DESCRIPTION	CORE DIAM.	MAX. LABEL WIDTH	NO. OF FLANGES	PRICE
81-213-0001	SHAFT, TC-CL	Coreless	-	6"	2	\$150
81-213-0002	SHAFT, TC-1"	Fin-Style	1"	6"	2	\$125
81-213-0003	SHAFT, TC-W6	Fin-Style	3"	6"	2	\$150
81-213-0004	SHAFT, TC-W10	Fin-Style	3"	10"	2	\$200
81-246-0004	ACH-TC3*	Adjustable	1" - 4"	6"	1	\$300
81-197-0009	TC-C1.5-170	Mech. Core-Chuck	1.5"	6"	1	\$295
81-197-0010	TC-C1.5-270	Mech. Core-Chuck	1.5"	10"	1	\$395
81-197-0014	TC-C40-170	Mech. Core-Chuck	40-mm	6"	1	\$295
81-197-0015	TC-C76-170	Mech. Core-Chuck	3"	6"	2	\$295
81-197-0016	TC-C76-220	Mech. Core-Chuck	3"	8"	2	\$395
81-197-0017	TC-C76-270	Mech. Core-Chuck	3"	10"	2	\$455
81-197-0011	TC-C100-170	Mech. Core-Chuck	4"	6"	1	\$345

*Cannot Mix and Match this Core Holder.
Not suitable for slitting applications.

Rewind Station Options

Enhance the versatility of your **TWIN-CAT-3** Label Rewind Station with the addition of these **optional upgrades**.

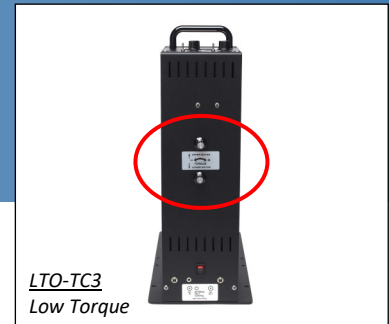
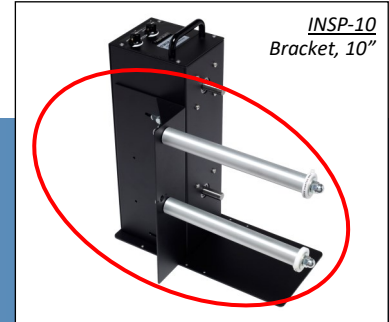
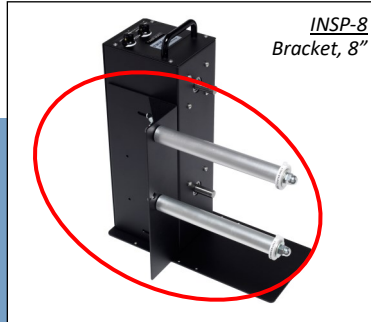
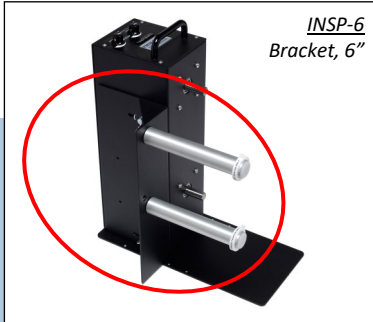

PART NO.	MODEL	DESCRIPTION	PRICE
81-164-0001	INSP-6	Inspection Bracket with Rollers for up to 6" (152-mm) wide labels.	\$195
81-164-0002	INSP-8	Inspection Bracket with Rollers for up to 8" (203-mm) wide labels.	\$225
81-164-0003	INSP-10	Inspection Bracket with Rollers for up to 10" (254-mm) wide labels.	\$255
81-141-0013	PCT-1	Digital Preset Counter for opaque labels with a gap.*	\$395
81-141-0014	PCT-2	Digital Preset Counter with scaling feature for opaque labels with a gap.*	\$495
10-155-0001	FOOTSWITCH	Pedal that starts or stops the Rewinder when pressed and held.	\$100
81-250-0003	LTO-TC3	Dual Control Low Torque Option for delicate label webs.	\$225
81-254-0002	FSPC-TC3	Option that permits simultaneous use of the Footswitch and the Automatic Stop feature of the Preset Counter.	\$175

*One of the INSP options must be ordered with this Counter.

Reel-to-Reel Printers

KEY FEATURES

- Table-top platform for coding labels on demand with the Markoprint inkjet printer
- Easily prints date codes, lot / serial numbers, variable sequential data, barcodes and logos
- Includes easy-to-use iDesign art software
- Save and print artwork with a USB Flash Drive or via direct LAN connection
- Printhead can be positioned to print anywhere on a label approximately 4" x 5.5" (101 - 140mm)
- Includes one black ink cartridge (provides approximately 30,000 - 50,000 prints, depending on size of artwork)
- Water and solvent based inks available for printing on high-gloss and porous surfaces
- Max. Print Height: 0.5" (12.7-mm)
- Max. Speed: 50 in/sec (1,270-mm)
- Max. Roll Weight: 15 lbs. (7-kg)
- Weight: 40 lbs. (18-kg)

Reel-to-Reel inkjet printers enable you to print variable data on pre-printed labels at high speed!



AUTOPRINT-300



Our partner **AT INFORMATION PRODUCTS** provides:

- Technical Product Support
- Replacement Ink Cartridges
- Limited Warranty

Web: atip-usa.com Telephone: (201) 529-0202

PART NO.	MODEL	UNWIND CORE	REWIND CORE	MAX. ROLL DIAMETER	MAX. LABEL WIDTH	PRICE
----------	-------	-------------	-------------	--------------------	------------------	-------

Opaque Labels (Standard)

80-196-0007	AUTOPRINT-300	3" (76-mm)	3" (76-mm)	13" (330-mm)	6" (115-mm)	Call for Pricing
-------------	---------------	---------------	---------------	-----------------	----------------	------------------

Transparent & Opaque Labels (Ultrasonic)

80-196-0008	AUTOPRINT-300-U	3" (76-mm)	3" (76-mm)	13" (330-mm)	6" (115-mm)	Call for Pricing
-------------	-----------------	---------------	---------------	-----------------	----------------	------------------

Options for Reel-to-Reel Printers

81-205-0033	ROLLER KIT, AUTO-8	8" Roller Kit Upgrade. Enables the unit to handle labels up to 8" wide.				\$315
81-205-0034	ROLLER KIT, AUTO-10	10" Roller Kit Upgrade. Enables the unit to handle labels up to 10" wide.				\$395

*Linear speed varies based upon roll diameter and weight.

Label Roll Splicing Systems

Label roll **Splicing Packages** are the ideal solution for splicing together **multiple rolls into a single roll**.

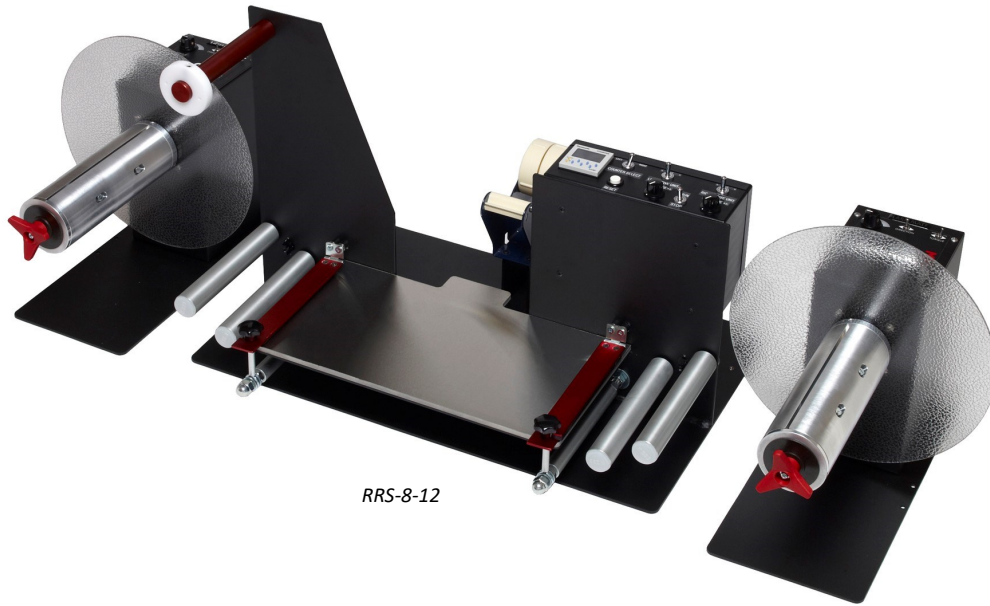

RRS-8-12

KEY FEATURES

- Independently controlled, bi-directional Rewinders
- Variable speed control
- Stainless steel splice table with milled knife grooves
- Preset digital counter with preset stop capability
- Inner & outer guide flanges for both Rewinders
- Adjustable tension control
- Wind-in or wind-out
- Max. Speed: 304 in/sec* (7,720-mm)
- Max. Roll weight: 20 lbs. (9-kg)
- Weight: 114 - 118 lbs. (51 - 54-kg) depending on model
- Full 3-Year Parts & Labor Limited Warranty

RRS-8 Label Splicing Systems provide a turnkey solution for **splicing label rolls together** to make one large roll from multiple small rolls, or to **change label types** during a production run.

Choose the **RRS-8-12** for roll diameters up to 12" (305mm), or the **RRS-8-16** for roll diameters up to 16" (406mm).

PART NO.	MODEL	CORE DIAMETER	MAX. ROLL DIAMETER	MAX. LABEL WIDTH	PRICE
80-218-0001	RRS-8-12	3" (76-mm)	12" (305-mm)	8" (203-mm)	\$4,595
80-218-0002	RRS-8-16	3" (76-mm)	16" (406-mm)	8" (203-mm)	\$4,995

Options for Splicing Systems

81-101-0001	ADAPT-326	Set of two Core Adapters for 6" diameter Cores. One set needed per Rewinder.	\$30
-------------	-----------	---	------

*Linear speed varies based upon roll diameter and weight.

Powered Unwinders

*Eliminate stress on your printer by feeding labels with a **Powered Unwinder**.*

UCAT-3

Max. Roll Diameter: 12" (305-mm)

UCAT-40

Max. Roll Diameter: 16" (406-mm)

KEY FEATURES

- Sensor Arm automatically starts and stops the Unwinder with the printer
- Use larger supply rolls for greater economy
- Adjustable speed control
- Max. Speed: 120 in/sec (3,048-mm)*
- Max. Roll Weight: 20 lbs. (9-kg)
- Weight: 27 - 33 lbs. (12 - 15-kg) depending on model
- Full 5-Year Parts & Labor Limited Warranty



UCAT-3-CHUCK

PART NO.	MODEL	CORE HOLDER	CORE DIAM.	MAX. LABEL WIDTH	MAX. ROLL DIAM.	PRICE
----------	-------	-------------	------------	------------------	-----------------	-------

12" Roll Diameter (UCAT-3)

80-237-0012	UCAT-3-ACH	Adjustable	1" - 4" (25 - 101-mm)	6" (152-mm)	11" (280-mm)	\$1,245
80-237-0016	UCAT-3- -STANDARD	Fin-Style (3")	3" (76-mm)	6" (152-mm)	12" (305-mm)	\$990
80-237-0013	UCAT-3-CHUCK	Mechanical Chuck	3" (76-mm)	6" (152-mm)	12" (305-mm)	\$1,195
80-237-0015	UCAT-3- -CHUCK-220	Mechanical Chuck	3" (76-mm)	8" (203-mm)	12" (305-mm)	\$1,255
80-237-0014	UCAT-3- -CHUCK-10	Mechanical Chuck	3" (76-mm)	10" (254-mm)	12" (305-mm)	\$1,315
80-237-0017	UCAT-3-W10	Fin-Style	3" (76-mm)	10" (254-mm)	12" (305-mm)	\$1,045

16" Roll Diameter (UCAT-40)

80-237-0018	UCAT-40	Mechanical Chuck	3" (76-mm)	6" (152-mm)	16" (406-mm)	\$1,395
80-237-0020	UCAT-40-220	Mechanical Chuck	3" (76-mm)	8" (203-mm)	16" (406-mm)	\$1,455
80-237-0019	UCAT-40-10	Mechanical Chuck	3" (76-mm)	10" (254-mm)	16" (406-mm)	\$1,495

*Linear speed varies based upon roll diameter and weight.

Non-Powered Unwinders

Non-Powered Unwinders are an excellent solution for controlling unruly supply rolls.



UCAT-S

UCAT-S

No Tension control

UCAT-1

Limited Adjustable Tension Control

KEY FEATURES

- *No Power Adaptor required*
- *Printer pulls labels from the Unwinder*
- *Use larger supply rolls for greater economy*
- *Maximum Roll Weight: 20 lbs. (9-kg)*
- *Weight: 18 - 32 lbs. (8 - 15-kg) depending on model*
- *Full 5-Year Parts & Labor Limited Warranty*

PART NO.	MODEL	CORE HOLDER	CORE DIAM.	MAX. LABEL WIDTH	MAX. ROLL DIAM.	PRICE
UCAT-S						
80-237-0021	UCAT-S	Fin-Style (3")	3" (76-mm)	6" (152-mm)	12" (305-mm)	\$295
UCAT-1						
80-237-0001	UCAT-1-1-INCH	Fin-Style (1")	1" (25-mm)	6" (152-mm)	12" (305-mm)	\$695
80-237-0002	UCAT-1-ACH	Adjustable	1" - 4" (25 - 101-mm)	6" (152-mm)	11" (280-mm)	\$895
80-237-0010	UCAT-1-STANDARD	Fin-Style (3")	3" (76-mm)	6" (152-mm)	12" (305-mm)	\$695
80-237-0003	UCAT-1-CHUCK	Mechanical Chuck	3" (76-mm)	6" (152-mm)	12" (305-mm)	\$895
80-237-0005	UCAT-1-CHUCK-220	Mechanical Chuck	3" (76-mm)	8" (203-mm)	12" (305-mm)	\$955

Unwinder Options

Enhance the versatility of your UCAT Label Unwinder with the addition of these **optional upgrades**.



PART NO.	MODEL	DESCRIPTION	PRICE
81-153-0011	FLANGE, OUT, STD	12" diameter Outer Guide Flange. For use with Fin-Style Shaft.	\$55
81-153-0015	FLANGE, OUT, QC-12	12" diameter Outer Guide Flange. For use with Mechanical "Quick-Chuck" Core Holder.	\$55
81-153-0016	FLANGE, OUT, QC-16	16" diameter Outer Guide Flange. For use with Mechanical "Quick-Chuck" Core Holder.	\$85
81-101-0001	ADAPT-326	Set of Core Adapters for 6" diameter Cores. Can only be used on Rewinders with a "Quick-Chuck" Core Holder.	\$30
81-102-0001	APG-CAT	Adjustable Paper Guide, used primarily with the CAT-3-ACH Rewinder. Maintains flush outer roll edge.	\$65

In-Line Slitter/Rewinders

Slit and rewind "in-line" directly from the printer without placing any stress at all on the printer!

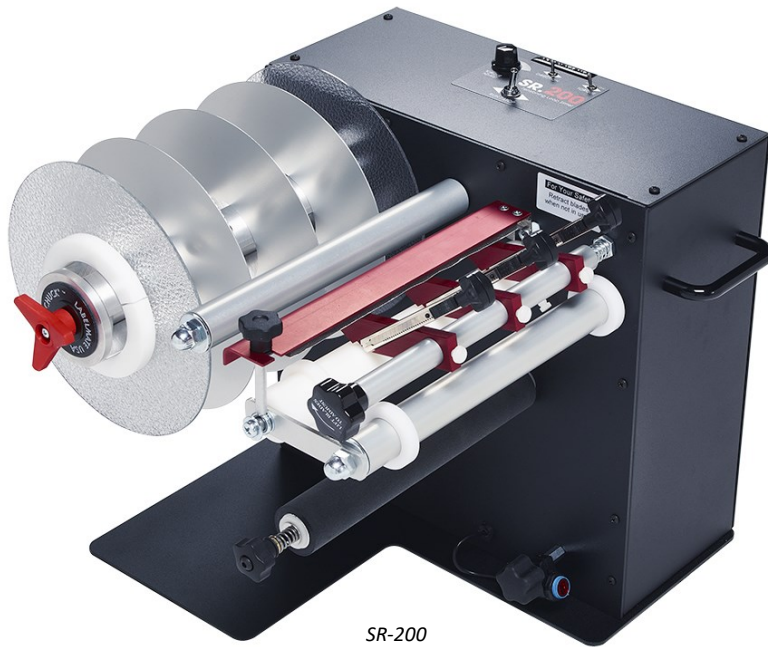

SR-200

LEFT Orientation shown

SR-100

2 Blades

2 Aluminum Separator Plates

Mechanical Core-Chuck - 3" x 6.5" (76 x 165-mm)

SR-200

3 Blades

3 Aluminum Separator Plates

Mechanical Core-Chuck - 3" x 10.5" (76 x 265-mm)

KEY FEATURES

- Eliminates ALL tension on printer!
- Adjustable tension control for finish-rolls
- Optical Sensor starts/stops Slitter in unison with printer
- Desired Rewind Orientation (Left or Right) is specified at time of purchase
- Max. Speed: 25 in/sec (635-mm)*
- Max. Roll weight: 20 lbs. (9-kg)
- Weight: 51 - 55 lbs. (23 - 25-kg) depending on model
- Full 3-Year Parts & Labor Limited Warranty

All SR-100/200 Rewinders are built-to-order for use on either the **Left** or **Right** side of your printer.

Specify desired orientation (Left or Right) at time of purchase.

PART NO.	MODEL	NO. OF BLADES	CORE DIAM.	MAX. MEDIA WIDTH	MIN. MEDIA WIDTH	MAX. ROLL DIAM.	PRICE
80-239-0005	SR-100	2	3" (76-mm)	6" (152-mm)	0.5" (12.7-mm)	8.5" (216-mm)	\$1,995
80-239-0007	SR-200	3	3" (76-mm)	10" (254-mm)	0.5" (12.7-mm)	8.5" (216-mm)	\$2,395

Options for In-Line Slitter/Rewinders

81-141-0011	PCS-1	Digital Preset Counter (factory installed). Only for opaque labels with a gap.	\$395
81-141-0012	PCS-2	Digital Preset Counter with scaling feature for multi-up labels (factory installed). For opaque labels with a gap.	\$495

*Linear speed varies based upon roll diameter and weight.

Slitting Packages

"Off-line" Slitting Packages are your solution for slitting rolls with multi-up rows of labels into individual finish-rolls.

SLIT-100-DELUXE

2 Blades

2 Aluminum 8" dia. Separator Plates
Mechanical Core-Chucks - 3" x 6.5" (76 x 165-mm)

SLIT-200-DELUXE

3 Blades

3 Aluminum 8" dia. Separator Plates
Mechanical Core-Chucks - 3" x 10.5" (76 x 265-mm)

KEY FEATURES

- **Two CAT-3 Rewinders**
- **HSB-10 Pack of replacement high-speed blades**
- **Max. Speed: 30 in/sec (762-mm)**
- **Max. Roll weight: 20 lbs. (9-kg)**
- **Weight: SLIT-100-DELUXE, 73 lbs. (33-kg)**
SLIT-200-DELUXE, 79 lbs. (36-kg)
- **Optional PCS-1 or PCS-2 Digital Counter purchased separately**
- **Full Limited Warranty:**
Rewinders - 5 years / Slitters - 3 years



*The **SLIT-100-DELUXE** can be used to slit media up to 6" (152-mm) wide.*

*The **SLIT-200-DELUXE** can be used to slit media up to 10" (254-mm) wide.*

Additional Blades and Separator Plates can be added to either Slit Package as desired.

PART NO.	MODEL	NO. OF BLADES	CORE DIAM.	MAX. MEDIA WIDTH	MIN. MEDIA WIDTH	MAX. ROLL DIAM.	PRICE
80-267-0001	SLIT-100-DELUXE	2	3" (76-mm)	6" (152-mm)	0.5" (12.7-mm)	12" (305-mm)	\$2,995
80-267-0002	SLIT-200-DELUXE	3	3" (76-mm)	10" (254-mm)	0.5" (12.7-mm)	12" (305-mm)	\$3,395

Non-Motorized Slitters

Combine a **Non-Motorized Slitter** with a Rewinder to slit pre-printed rolls, or “in-line” directly from the printer.



S-200

S-100

Max. Media Width: 6” (152-mm)
2 Blades standard

S-200

Max. Media Width: 10” (254-mm)
3 Blades standard

KEY FEATURES

- Adjustable Blade placement for labels from 0.5” - 6” (12.7-152-mm)
- Additional Blades can be added as needed
- Non-Motorized Slitters are used together with CAT-3 Rewinders
- Can be used for both “in-line” and “off-line” applications
- Weight: 16 - 18 lbs. (7 - 8-kg) depending on model
- Full 3-Year Parts & Labor Limited Warranty

Combine a **Non-Motorized Slitter** with a Rewinder to slit labels (as many as 5-across) “in-line” as you rewind them from your printer, or “off-line” in a complete Label Slitting Package.

The **S-100** Label Slitter features **two blades** standard, and will handle media up to 6” (152-mm) wide.

The **S-200** features **three blades** standard, and will handle media up to 10” (254-mm) wide.

PART NO.	MODEL	REWINDER REQUIRED	NO. OF BLADES	MAX. MEDIA WIDTH	MIN. MEDIA WIDTH	PRICE
80-239-0001	S-100	CAT-3	2	6” (152-mm)	0.5” (12.7-mm)	\$695
80-239-0002	S-200	CAT-3	3	10” (254-mm)	0.5” (12.7-mm)	\$795

Slitter Options

Enhance the versatility of your Label Slitter with the addition of these *optional accessories*.

Aluminum Separator Plates

IMAGE	PART NO.	MODEL	CORE DIAMETER	ROLL DIAMETER	PRICE
	41-211-0001	SP-25-220AL	1" (25-mm)	8.6" (220-mm)	\$30
	41-211-0003	SP-38-220AL	1.5" (38-mm)	8.6" (220-mm)	\$30
	41-211-0009	SP-40-220AL	40-mm	8.6" (220-mm)	\$30
	41-211-0005	SP-76-220AL	3" (76-mm)	8.6" (220-mm)	\$30
	41-211-0006	SP-76-300AL	3" (76-mm)	12" (300-mm)	\$40
	41-211-0007	SP-76-400AL	3" (76-mm)	16" (400-mm)	\$55

Additional Accessories

IMAGE	PART NO.	MODEL	DESCRIPTION	PRICE
	81-115-0001	BH-1	Blade Holder Assembly	\$50
	70-117-0001	HSB-10	Precision Ultra-Sharp Slitter Blades (10-Pack)	\$25
	41-236-0001	LOCKING BAR	Adjustable Locking Bar	\$80
	81-141-0011	PCS-1	Digital Preset Counter*	\$395
	81-141-0012	PCS-2	Digital Preset Scaling Counter*	\$495

*Counter can be programmed to stop the machine when a preset count is reached.

Core-Chucks

“Quick-Chuck”[®] Core-Chucks are the optimum solution for super-fast loading, winding, and unloading label rolls.



KEY FEATURES

- All Quick-Chucks fit a 0.625” (15.87-mm) dia. shaft. A setscrew locks the Chuck in place to a flat on the shaft.
- Quick-Chucks are standard on premium model Rewinders and Unwinders.
- Quick-Chucks are ideal for heavy rolls and production operations.
- Custom configurations available!
- 3-Year Parts & Labor Limited Warranty

“Quick-Chuck”[®] Core-Chucks

PART NO.	MODEL	CORE DIAMETER	MAX. MEDIA WIDTH ¹	PRICE
80-197-0002	C1.5-170	1.5” (38-mm)	6.7” (170-mm)	\$295
80-197-0001	C1.5-270	1.5” (38-mm)	10.6” (270-mm)	\$395
80-197-0007	C40-170	1.575” (40-mm)	6.7” (170-mm)	\$295
80-197-0010	C76-160 ²	3” (76-mm)	6.0” (152-mm)	\$295
80-197-0004	C76-170	3” (76-mm)	6.7” (170-mm)	\$295
80-197-0005	C76-220	3” (76-mm)	8.6” (220-mm)	\$395
80-197-0003	C76-270	3” (76-mm)	10.6” (270-mm)	\$455
80-197-0008	C76-330	3” (76-mm)	13” (330-mm)	\$525
80-197-0006	C100-170	4” (102-mm)	6.7” (170-mm)	\$345



Options for “Quick-Chuck”[®] Core-Chucks

42-153-0004	FLANGE, INN, 12	Inner Guide Flange for Core-Chucks. 12” OD (305-mm).	\$40
81-153-0015	FLANGE, OUT, QC-12	Outer Guide Flange w/ Hub. 3” ID x 12” OD (305-mm).	\$55
42-153-0006	FLANGE, INN, 16	Inner Guide Flange for Core-Chucks. 16” OD (406-mm).	\$65
81-153-0016	FLANGE, OUT, QC-16	Outer Guide Flange w/ Hub. 3” ID x 16” OD (406-mm).	\$85
42-153-0008	FLANGE, INN, 18	Inner Guide Flange for Core-Chucks. 18” OD (457-mm).	\$70
81-153-0017	FLANGE, OUT, QC-18	Outer Guide Flange w/ Hub. 3” ID x 18” OD (457-mm).	\$90
81-102-0001	APG-CAT	Paper Guide. For use with Adjustable Core Holder.	\$65

1. Subtract 0.5” (12.3-mm) if using Outer Guide Flange.



2. Used with Reel-to-Reel machines only.

Payment

We accept , , , U.S. Checks, and Direct Bank Transfers. Call Toll Free **877.833.7149** or email accounting@labelmateusa.com to apply for Net 30 Day Terms (U.S. Businesses OAC) or to make other payment inquiries.

- Prices are listed in US Dollars, and shipments are F.O.B. Henderson, Nevada, 89014 USA.
- As we are continually improving our products, specifications and prices may change from time-to-time without notice.

Shipping

We ship via , , and many other freight carriers. Shipping charges cover freight, handling and insurance. Collect shipments are available with a valid shipping account number when carrier regulations permit.

Returns / Exchanges

A Return Materials Authorization (RMA) is required for all product returns and/or exchanges. Call Toll-Free **877.833.7149** or email info@labelmateusa.com to obtain an RMA. We are proud of our reputation for quality and customer service, and if for any reason you are not satisfied with your purchase you may return it in new condition in the original carton and packaging within ten (10) days of receipt for credit or exchange. Otherwise, returned products are subject to a restocking fee. Shipping charges are never refundable.

Product Information

All LABELMATE USA Products are proudly manufactured in the USA  unless otherwise noted. All products are RoHS compliant, and are UL, ETL, CSA and/or CE approved/certified as applicable.*



Unless otherwise specified, all LABELMATE USA products are for 120V 60-Hz. Models for 220V-240V 50-Hz are also available upon request.

Contact

- ◆ Toll Free: 877.833.7149
- ◆ Direct: +1.702.435.8535
- ◆ Fax: +1.702.435.8536
- ◆ Email: info@labelmateusa.com

Thank You for Choosing LABELMATE USA!

We Appreciate Your Business!

www.labelmateusa.com

© Copyright LABELMATE USA LLC 2000-2023. All rights reserved worldwide.

*Does not apply to Automatic Label Applicators.



LABELMATE USA

LABEL HANDLING INNOVATIONS



MADE IN THE USA



www.labelmateusa.com