

NOTES:

Automatic Label Dispenser for transparent & opaque labels up to 6.5" wide.

- Label Type: Opaque & Transparent
- Max. Label Width: 6.5" (165mm)
- Max. Roll Diameter: 8.5" (220mm)
- Finish: Stainless Steel
- Warranty: 3-Year Parts & Labor Limited Warranty

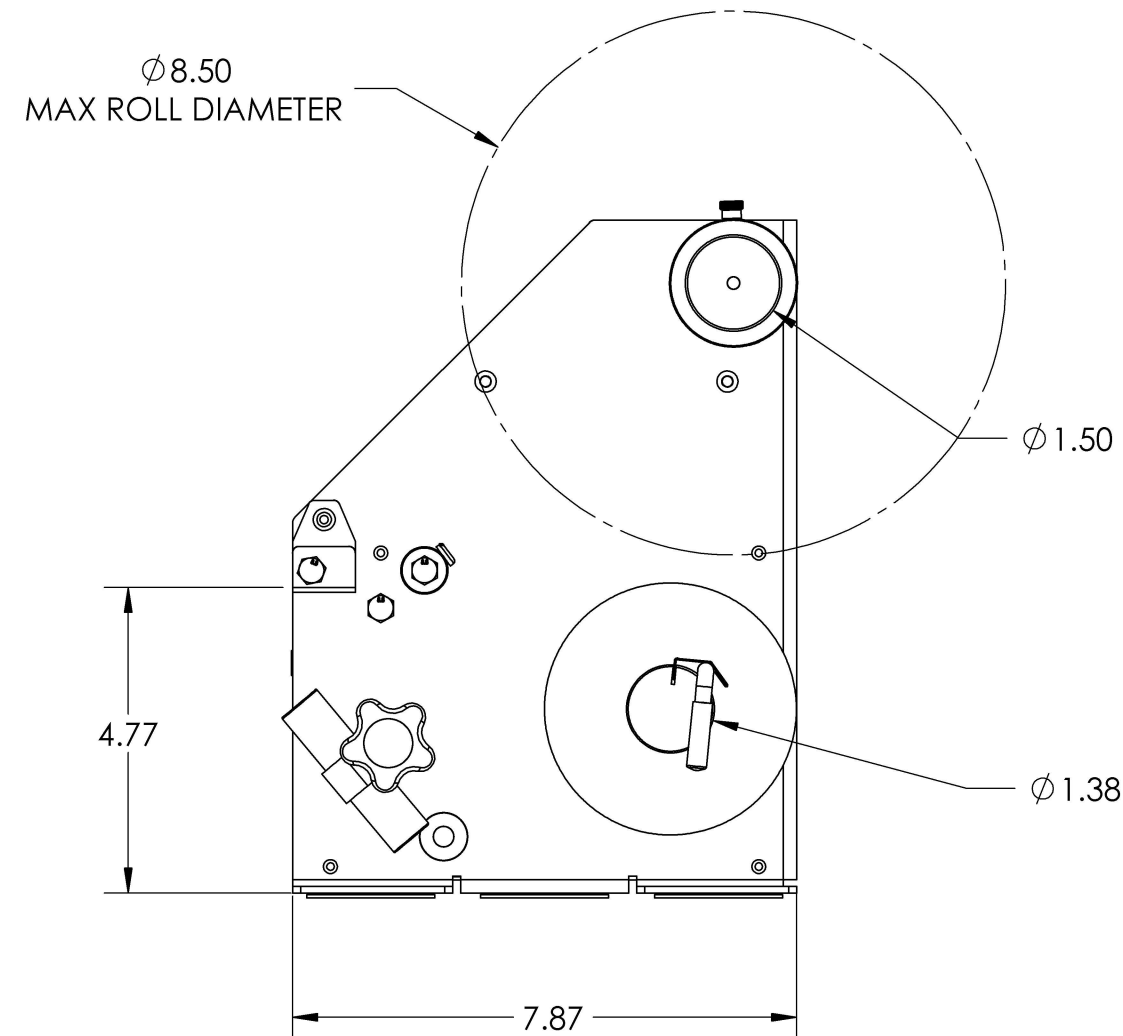
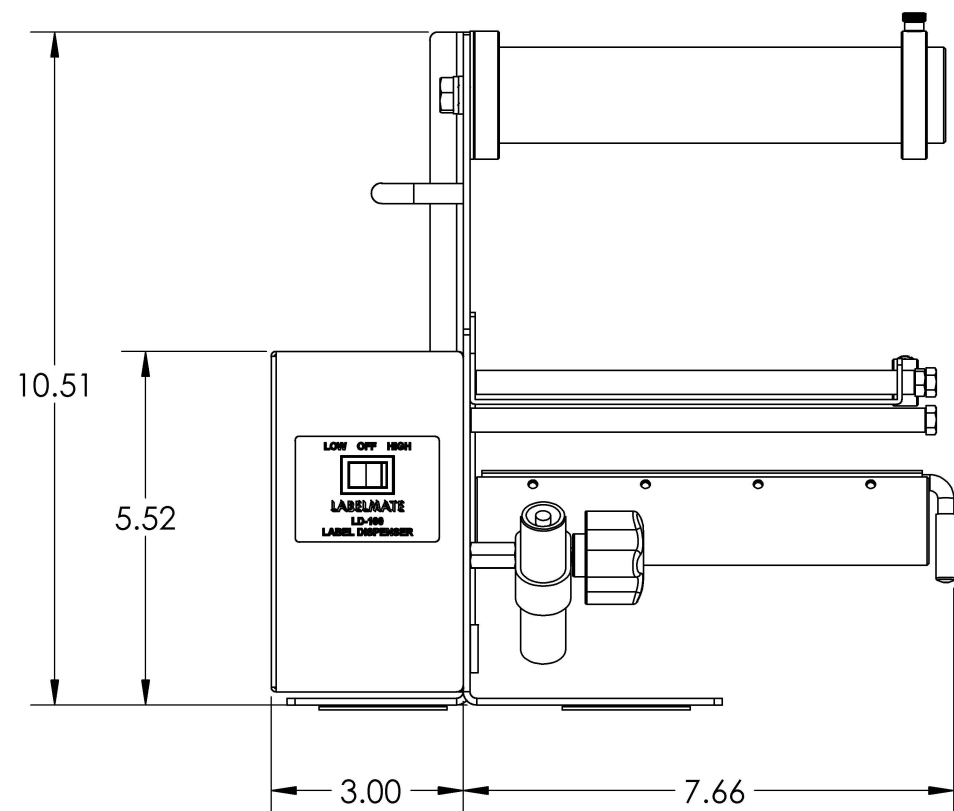

ITEM ID:

LD-200-U

DRAWN BY: TAH	DATE: 2/1/2023	PART NO. 80-147-0009
------------------	-------------------	-------------------------

POWER SUPPLY: PART NO. PS-1240	INPUT: 120VAC OUTPUT: 12VAC 3.3A
-----------------------------------	-------------------------------------